

# AQ-V251

Voltage protection device

Instruction manual



## Table of contents

1 Document information .....	5
1.1 Version 2 revision notes .....	5
1.2 Safety information .....	8
1.3 Abbreviations.....	10
2 General .....	12
3 Device user interface.....	13
3.1 Local panel structure .....	13
4 Functions .....	15
4.1 Functions included in AQ-V251.....	15
4.2 Measurements.....	16
4.2.1 Voltage measurement and scaling .....	16
4.2.2 Frequency tracking and scaling .....	31
4.3 General menu.....	34
4.4 Protection functions .....	37
4.4.1 General properties of a protection function .....	37
4.4.2 Circuit breaker failure protection (CBFP; 50BF/52BF) .....	46
4.4.3 Overvoltage protection (U>; 59) .....	61
4.4.4 Undervoltage protection (U<; 27) .....	68
4.4.5 Neutral overvoltage protection (U0>; 59N) .....	75
4.4.6 Sequence voltage protection (U1/U2><; 47/27P/59PN) .....	81
4.4.7 Low-voltage ride-through (27T) .....	89
4.4.8 Overfrequency and underfrequency protection (f><; 81O/81U).....	94
4.4.9 Rate-of-change of frequency (df/dt><; 81R) .....	98
4.4.10 Resistance temperature detectors (RTD) .....	103
4.4.11 Programmable stage (PSx><; 99) .....	106
4.5 Control functions .....	116
4.5.1 Common signals.....	116
4.5.2 Setting group selection .....	117
4.5.3 Object control and monitoring .....	121
4.5.4 Indicator object monitoring .....	129
4.5.5 Switch-on-to-fault (SOTF) .....	131
4.5.6 Vector jump ( $\Delta\phi$ ; 78) .....	133
4.5.7 Synchrocheck ( $\Delta V/\Delta a/\Delta f$ ; 25) .....	138
4.5.8 Synchronizer ( $\Delta V/\Delta a/\Delta f$ ; 25) .....	151
4.5.9 Milliampere output control .....	159
4.5.10 Programmable control switch .....	162
4.5.11 Function buttons .....	164
4.5.12 Analog input scaling curves .....	165
4.5.13 Logical outputs .....	167
4.5.14 Logical inputs .....	169
4.6 Monitoring functions .....	171
4.6.1 Voltage transformer supervision (60) .....	171
4.6.2 Voltage total harmonic distortion (THD) .....	176
4.6.3 Measurement recorder .....	180
4.6.4 Fault register .....	185
4.6.5 Event logger .....	189
4.6.6 Disturbance recorder (DR) .....	190
4.6.7 User access control.....	196
5 Communication .....	200
5.1 Connections menu.....	200
5.2 Time synchronization .....	204

5.2.1 Internal .....	204
5.2.2 NTP .....	204
5.2.3 PTP .....	205
5.3 Communication protocols .....	207
5.3.1 IEC 61850 .....	207
5.3.1.1 Logical device mode and logical node mode .....	209
5.3.1.2 GOOSE .....	213
5.3.2 Modbus TCP and Modbus RTU .....	217
5.3.3 IEC 103 .....	218
5.3.4 IEC 101/104 .....	219
5.3.5 SPA .....	221
5.3.6 DNP3 .....	222
5.3.7 Modbus I/O .....	225
5.3.8 OPCUA .....	226
5.3.9 Integration time .....	226
5.4 Analog fault registers .....	227
5.5 Modbus Gateway .....	228
<b>6 Connections and application examples .....</b>	<b>231</b>
6.1 Connections of AQ-V251 .....	231
6.2 Application example and its connections .....	231
<b>7 Construction and installation .....</b>	<b>233</b>
7.1 Construction .....	233
7.2 CPU module .....	236
7.3 Voltage measurement module .....	239
7.4 Option cards .....	240
7.4.1 Digital input module (optional) .....	240
7.4.2 Digital output module (optional) .....	243
7.4.3 High-speed and high-current output module (optional) .....	245
7.4.4 Milliampere output module (4x mA out & 1x mA in) (optional) .....	247
7.4.5 Milliampere input module (4x mA in & 1x mA out) (optional) .....	249
7.4.6 RTD input module (optional) .....	250
7.4.7 Double RJ45 Ethernet & IRIG-B communication module (optional) .....	251
7.4.8 Double SFP Ethernet & IRIG-B communication module (optional) .....	252
7.4.9 Double ST 100 Ethernet & IRIG-B communication module (optional) .....	253
7.4.10 Double LC or RJ45 (HSR/PRP) Ethernet communication module (optional) .....	254
7.4.11 Serial RS-232 communication module (optional) .....	255
7.5 Dimensions and installation .....	256
<b>8 Technical data .....</b>	<b>259</b>
8.1 Hardware .....	259
8.1.1 Measurements .....	259
8.1.1.1 Voltage measurement .....	259
8.1.1.2 Voltage memory .....	260
8.1.1.3 Frequency measurement .....	260
8.1.2 CPU & Power supply .....	261
8.1.2.1 Auxiliary voltage .....	261
8.1.2.2 CPU communication ports .....	262
8.1.2.3 CPU digital inputs .....	263
8.1.2.4 CPU digital outputs .....	263
8.1.3 Option cards .....	264
8.1.3.1 Digital input module .....	264
8.1.3.2 Digital output module .....	265
8.1.3.3 High-speed and high-current output module .....	265
8.1.3.4 Milliampere output module (4 x mA out & 1 x mA in) .....	266
8.1.3.5 Milliampere input module (1x mA out & 4x mA in) .....	267
8.1.3.6 RTD input module .....	268
8.1.3.7 Double RJ-45 Ethernet & IRIG-B communication module .....	268

8.1.3.8 Double SFP Ethernet & IRIG-B communication module .....	269
8.1.3.9 Double ST Ethernet & IRIG-B communication module .....	269
8.1.3.10 Double LC (HSR/PRP) Ethernet communication module.....	270
8.1.3.11 Double RJ-45 (HSR/PRP) Ethernet communication module.....	270
8.1.3.12 RS-232 & serial fiber communication module.....	271
8.1.4 Display .....	271
8.2 Functions.....	272
8.2.1 Protection functions.....	272
8.2.1.1 Circuit breaker failure protection (CBFP; 50BF/52BF) .....	272
8.2.1.2 Overvoltage protection (U>; 59) .....	273
8.2.1.3 Undervoltage protection (U<; 27) .....	274
8.2.1.4 Neutral overvoltage protection (U0>; 59N).....	275
8.2.1.5 Sequence voltage protection (U1/U2>/<; 47/27P/59NP) .....	276
8.2.1.6 Overfrequency and underfrequency protection (f>/<; 81O/81U).....	277
8.2.1.7 Resistance temperature detectors (RTD) .....	277
8.2.2 Control functions .....	278
8.2.2.1 Setting group selection .....	278
8.2.2.2 Object control and monitoring.....	278
8.2.2.3 Indicator object monitoring .....	279
8.2.2.4 Switch-on-to-fault (SOTF) .....	280
8.2.2.5 Vector jump ( $\Delta\phi$ ; 78) .....	280
8.2.2.6 Synchrocheck ( $\Delta V/\Delta a/\Delta f$ ; 25) .....	281
8.2.3 Monitoring functions .....	282
8.2.3.1 Voltage transformer supervision (60) .....	282
8.2.3.2 Event logger .....	283
8.2.3.3 Disturbance recorder.....	283
8.3 Tests and environmental .....	283
9 Ordering information .....	286
10 Contact and reference information.....	288

## Disclaimer

Please read these instructions carefully before using the equipment or taking any other actions with respect to the equipment. Only trained and qualified persons are allowed to perform installation, operation, service or maintenance of the equipment. Such qualified persons have the responsibility to take all appropriate measures, including e.g. use of authentication, encryption, anti-virus programs, safe switching programs etc. necessary to ensure a safe and secure environment and usability of the equipment. The warranty granted to the equipment remains in force only provided that the instructions contained in this document have been strictly complied with.

Nothing contained in this document shall increase the liability or extend the warranty obligations of the manufacturer Arcteq Relays Ltd. The manufacturer expressly disclaims any and all liability for any damages and/or losses caused due to a failure to comply with the instructions contained herein or caused by persons who do not fulfil the aforementioned requirements. Furthermore, the manufacturer shall not be liable for possible errors in this document.

Please note that you must always comply with applicable local legislation and regulations. The manufacturer gives no warranties that the content of this document is in all respects in line with local laws and regulations and assumes no liability for such possible deviations.

You are advised to notify the manufacturer in case you become aware of any errors in this document or of defects in the equipment.

The manufacturer reserves the right to update or amend this document at any time.

## Copyright

Copyright © Arcteq Relays Ltd. 2026. All rights reserved.

# 1 Document information

## 1.1 Version 2 revision notes

Table. 1.1 - 1. Version 2 revision notes

Revision	2.00
Date	6.6.2019
Changes	<ul style="list-style-type: none"> <li>- New more consistent look.</li> <li>- Improved descriptions generally in many chapters.</li> <li>- Improved readability of a lot of drawings and images.</li> <li>- Updated protection functions included in every manual.</li> <li>- Every protection relay type now has connection drawing, application example drawing with function block diagram and application example with wiring.</li> </ul>
Revision	2.01
Date	6.11.2019
Changes	<ul style="list-style-type: none"> <li>- Added description for LED test and button test.</li> <li>- Added display sleep timer description.</li> <li>- Complete rewrite of every chapter.</li> <li>- Improvements to many drawings and formula images.</li> <li>- Order codes revised.</li> </ul>
Revision	2.02
Date	7.7.2020
Changes	
Revision	2.03
Date	27.8.2020
Changes	<ul style="list-style-type: none"> <li>- Terminology consistency improved (e.g. binary inputs are now always called digital inputs).</li> <li>- Tech data modified to be more informative about what type of measurement inputs are used (phase currents/voltages, residual currents/voltages), what component of that measurement is available (RMS, TRMS, peak-to-peak) and possible calculated measurement values (powers, impedances, angles etc.).</li> <li>- Improvements to many drawings and formula images.</li> <li>- Event read mode parameter added to Modbus description.</li> <li>- Added inches to Dimensions and installation chapter.</li> <li>- Added raising frames, wall mounting bracket, combiflex frame to order code.</li> <li>- Added logical input and logical output function descriptions.</li> <li>- Additions to Abbreviations chapter.</li> <li>- Added button test description to Local panel structure chapter.</li> <li>- Added note to Configuring user levels and passwords chapter that AQ-250 frame units generate a time-stamped event from locking and unlocking user levels.</li> <li>- Added note to Configuring user levels and passwords chapter that user level with a password automatically locks itself after 30 minutes of inactivity.</li> <li>- Added more "Tripped stage" indications and fault types to Measurement value recorder function.</li> <li>- Added sample rate to voltage and current measurement tech data.</li> </ul>

Revision	2.04
Date	8.6.2021
Changes	<ul style="list-style-type: none"> <li>- Increased the consistency in terminology</li> <li>- Various image upgrades</li> <li>- Visual update to the order codes</li> </ul>
Revision	2.05
Date	22.6.2021
Changes	<ul style="list-style-type: none"> <li>- Fixed phase current measurement continuous thermal withstand from 30A to 20A.</li> <li>- Fixed lots of timing errors written to registers table. "Prefault" is -200 ms from Start event, "Pretrigger" is -20 ms from trip (or start if fault doesn't progress to trip), "Fault" is start (or trip if fault doesn't progress to trip).</li> <li>- Added event history technical data</li> </ul>
Revision	2.06
Date	21.6.2022
Changes	<ul style="list-style-type: none"> <li>- Improved descriptions generally in many chapters.</li> <li>- Improved readability of a lot of drawings and images.</li> <li>- Order codes have been revised.</li> <li>- Added LN mode parameters to all functions (On, Blocked, Test, Test/Blocked, Off).</li> <li>- Added color themes parameter description.</li> <li>- Improved color sleep mode description.</li> <li>- Improved alarm function color behavior description and images.</li> <li>- Added operation time with different measurement values vs setting ratio in instant operation mode to non-directional overcurrent function description.</li> <li>- Added 30 s pretriggering time for disturbance recorder (AQ-250 devices only).</li> <li>- Added new trip detections and fault types to measurement value recorder.</li> <li>- Added user description parameter descriptions for digital inputs, digital outputs, logical inputs, logical outputs and GOOSE inputs.</li> <li>- Added spare part codes and compatibilities to option cards.</li> </ul>
Revision	2.07
Date	7.7.2022
Changes	<ul style="list-style-type: none"> <li>- Added <a href="#">THD voltage measurements</a>.</li> <li>- Fixed number of <a href="#">logical inputs</a>.</li> <li>- Added <a href="#">common signals</a> function description.</li> <li>- Added <a href="#">PTP time synchronization</a> description.</li> <li>- Added <a href="#">Modbus Gateway</a> description.</li> </ul>
Revision	2.08
Date	8.9.2022

Changes	<ul style="list-style-type: none"> <li>- Added stage forcing parameter to function descriptions.</li> <li>- Fixes to "Real time signals to comm" description.</li> <li>- Added "Ethernet port" parameter description to <a href="#">IEC61850</a>, <a href="#">IEC104</a> and <a href="#">Modbus TCP</a> descriptions.</li> <li>- Removed "Measurement update interval" settings from Modbus description. No longer in use.</li> <li>- Renamed "System integration" chapter to "<a href="#">Communication</a>" and restructured the chapters to be closer to how they are in the menus.</li> <li>- Added "<a href="#">Event logger</a>" chapter.</li> <li>- Added more descriptions to new IEC 61850 ed2 GOOSE parameters.</li> <li>- Added "Condition monitoring / CB wear" description to object description.</li> <li>- Added "<a href="#">User button</a>" description.</li> <li>- Added logical device and logical node mode descriptions.</li> </ul>
Revision	2.09
Date	14.3.2023
Changes	<ul style="list-style-type: none"> <li>- Updated the Arcteq logo on the cover page and refined the manual's visual look.</li> <li>- Added the "<a href="#">Safety information</a>" chapter and changed the notes throughout the document accordingly.</li> <li>- Changed the "IED user interface" chapter's title to "Device user interface" and replaced all 'IED' terms with 'device' or 'unit'.</li> <li>- Updated the rated values for the change-over CPU digital outputs in "Technical data".</li> <li>- Updated the input impedance for the voltage measurement module in "<a href="#">Technical data</a>".</li> <li>- Added double ethernet port configuration parameters to "<a href="#">Connections menu</a>" chapter.</li> <li>- Added event overload detection description to "<a href="#">Event logger</a>" chapter.</li> <li>- Added parameter descriptions to <a href="#">Synchronizer description</a> chapter.</li> </ul>
Revision	2.10
Date	19.6.2023
Changes	<ul style="list-style-type: none"> <li>- Updated order codes.</li> </ul>
Revision	2.11
Date	29.11.2023
Changes	<ul style="list-style-type: none"> <li>- Added the 5 ms update time in the measurement chapters.</li> <li>- Added spring lock cage options for connectors. See the "<a href="#">Ordering information</a>" chapter.</li> <li>- Updated the contact address for technical support in the "<a href="#">Contact and reference information</a>" chapter.</li> <li>- Circuit breaker wear is not integrated to the <a href="#">objects</a>.</li> </ul>
Revision	2.12
Date	January 2024
Changes	<ul style="list-style-type: none"> <li>- Added "<a href="#">Switch-on-to-fault</a>" function to AQ-V251.</li> <li>- Added Chinese and Kazakh languages as language options in "<a href="#">General menu</a>".</li> </ul>
Revision	2.13
Date	September 2024
Changes	<ul style="list-style-type: none"> <li>- Corrected the number of devices that fit a 19 in rack in the "<a href="#">Dimensions and installation</a>" chapter.</li> </ul>
Revision	2.14

Date	June 2025
Changes	<ul style="list-style-type: none"> <li>- Increased phase current measurement range. See the current measurement section in the Technical data chapter.</li> <li>- Updated the product and packaging weights.</li> <li>- Added new "<a href="#">User access control</a>" description.</li> <li>- Added "<a href="#">High-speed and high-current output</a>" option card description.</li> <li>- Added "<a href="#">Milliampere input module (4x mA in &amp; 1x mA out)</a>" option card description.</li> <li>- Added "<a href="#">Double SFP Ethernet &amp; IRIG-B communication module</a>" option card description.</li> <li>- <a href="#">Order code</a> table updated.</li> </ul>
Revision	2.15
Date	January 2026
Changes	<ul style="list-style-type: none"> <li>- Added "<a href="#">Low-voltage ride-through</a>" function description.</li> <li>- Updated the Connections images.</li> </ul>
Revision	2.16
Date	June 2026
Changes	<ul style="list-style-type: none"> <li>- General improvements to descriptions.</li> <li>- IEC61850 <a href="#">integration time</a> description improved.</li> <li>- Added <a href="#">CBW abrasion (SCBR) calculation</a> description.</li> <li>- Added measurements to <a href="#">Programmable stages</a>.</li> <li>- Added <a href="#">OPCUA</a> communication protocol.</li> </ul>

## 1.2 Safety information

This document contains important instructions that should be saved for future use. Read the document carefully before installing, operating, servicing, or maintaining this equipment. Please read and follow all the instructions carefully to prevent accidents, injury and damage to property.

Additionally, this document may contain four (4) types of special messages to call the reader's attention to useful information as follows:



### NOTICE!

"Notice" messages indicate relevant factors and conditions to the concept discussed in the text, as well as to other relevant advice.



### CAUTION!

"Caution" messages indicate a potentially hazardous situation which, if not avoided, could result in minor or moderate personal injury, in equipment/property damage, or software corruption.



### WARNING!

"Warning" messages indicate a potentially hazardous situation which, if not avoided, could result in death or serious personal injury as well as serious damage to equipment/property.



### DANGER!

"Danger" messages indicate an imminently hazardous situation which, if not avoided, will result in death or serious personal injury.

These symbols are added throughout the document to ensure all users' personal safety and to avoid unintentional damage to the equipment or connected devices.

Please note that although these warnings relate to direct damage to personnel and/or equipment, it should be understood that operating damaged equipment may also lead to further, indirect damage to personnel and/or equipment. Therefore, we expect any user to fully comply with these special messages.

## 1.3 Abbreviations

AI	– Analog input
AR	– Auto-recloser
ASDU	– Application service data unit
AVR	– Automatic voltage regulator
BCD	– Binary-coded decimal
CB	– Circuit breaker
CBFP	– Circuit breaker failure protection
CLPU	– Cold load pick-up
CPU	– Central processing unit
CT	– Current transformer
CTM	– Current transformer module
CTS	– Current transformer supervision
DG	– Distributed generation
DHCP	– Dynamic Host Configuration Protocol
DI	– Digital input
DO	– Digital output
DOL	– Direct-on-line
DR	– Disturbance recorder
DT	– Definite time
FF	– Fundamental frequency
FFT	– Fast Fourier transform
FTP	– File Transfer Protocol
GI	– General interrogation
HMI	– Human-machine interface
HR	– Holding register
HV	– High voltage
HW	– Hardware
IDMT	– Inverse definite minimum time
IGBT	– Insulated-gate bipolar transistor

I/O – Input and output

IRIG-B – Inter-range instruction group, timecode B

LCD – Liquid-crystal display

LED – Light emitting diode

LV – Low voltage

NC – Normally closed

NO – Normally open

NTP – Network Time Protocol

RMS – Root mean square

RSTP – Rapid Spanning Tree Protocol

RTD – Resistance temperature detector

RTU – Remote terminal unit

SCADA – Supervisory control and data acquisition

SG – Setting group

SOTF – Switch-on-to-fault

SW – Software

THD – Total harmonic distortion

TRMS – True root mean square

VT – Voltage transformer

VTM – Voltage transformer module

VTS – Voltage transformer supervision

## 2 General

The AQ-V251 voltage protection device is a member of the AQ 250 product line. The hardware and software are modular: the hardware modules are assembled and configured according to the application's I/O requirements and the software determines the available functions. This manual describes the specific application of the AQ-V251 voltage protection device. For other AQ 200 and AQ 250 series products please consult their respective device manuals.

AQ-V251 offers a modular voltage protection solution for substations with voltage and frequency protection, synchrocheck and synchronizer. There are up to thirteen (13) option card slots available for additional I/O or communication cards. These with the option for powerful logic programming make AQ-V251 optimal for demanding load shedding or automatic transfer applications. AQ-V251 communicates using various protocols including the IEC 61850 substation communication standard.

## 3 Device user interface

### 3.1 Local panel structure

The front panel of AQ-250 series devices have multiple LEDs, control buttons and a local RJ-45 Ethernet port for configuration. Each unit is also equipped with an RS-485 serial interface and an RJ-45 Ethernet interface on the back of the device.

Figure. 3.1 - 1. Local panel structure.

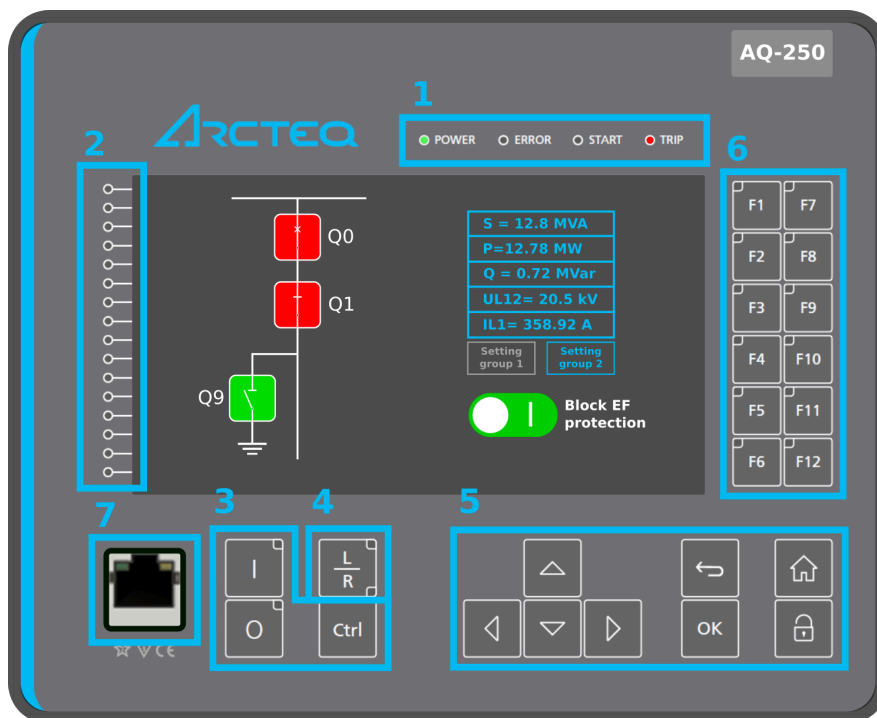

1. Four (4) default LEDs: "Power", "Error", "Start" (configurable) and "Trip" (configurable).
2. Sixteen (16) freely configurable LEDs (red, orange, green) with programmable legend texts.
3. Three (3) object control buttons: Choose the controllable object with the Ctrl button and control the breaker or other object with the I and the O buttons.
4. The L/R button switches between the local and the remote control modes.
5. Eight (8) buttons for device local programming: the four navigation arrows, the Back and the OK buttons, the Home and the password activation buttons).
6. Twelve (12) freely configurable function buttons (F1...F12). Each button has a freely configurable LED (red, orange, green).
7. One (1) RJ-45 Ethernet port for device configuration.

When the unit is powered on, the green "Power" LED is lit. When the red "Error" LED is lit, the device has an internal (hardware or software) error that affects the operation of the unit. The activation of the yellow "Start" LED and the red "Trip" LED are based on the setting the user has put in place in the software.

The sixteen freely configurable LEDs are located on the left side of the display. Their activation and color (green, orange, red) are based on the settings the user has put in place in the software.

The view in the screen is freely configurable. Virtual switches and buttons can be added which can be used to change the setting groups or control the device's general logic locally or remotely. The status of the object (circuit breaker, disconnect) can be displayed on the screen. All measured and calculated values regardless of the magnitude category (current, voltage, power, energy, frequency, etc.) can be shown on the screen.

Holding the I (object control) button down for five seconds brings up the button test menu. It displays all the physical buttons on the front panel. Pressing any of the listed buttons marks them as tested. When all buttons are marked as having been tested, the device will return back to the default view.

## 4 Functions

### 4.1 Functions included in AQ-V251

The AQ-V251 voltage protection device includes the following functions as well as the number of stages in those functions.

Table. 4.1 - 2. Protection functions of AQ-V251.

Name	IEC	ANSI	Description
OV (4)	U> U>> U>>> U>>>>	59	Overvoltage protection
UV (4)	U< U<< U<<< U<<<<	27	Undervoltage protections
NOV (4)	U0> U0>> U0>>> U0>>>>	59N	Neutral overvoltage protection
LVRT (1)	LVRT	27T	Low-voltage ride-through protection
FRQV (8)	f> f>> f>>> f>>>> f< f<< f<<< f<<<<	81O/81U	Overfrequency and underfrequency protection
ROCOF (8)	df/dt>/<	81R	Rate-of-change of frequency
VUB (4)	U1/U2>/< U1/U2>>/<< U1/U2>>>/<<< U1/ U2>>>>/<<<<	47/27P/59PN	Sequence voltage protection
CBFP (1)	CBFP	50BF/52BF	Circuit breaker failure protection
RTD (1...16)	-	-	RTD alarms (Resistance temperature detector)
PGS (1)	PGx>/<	99	Programmable stage

Table. 4.1 - 3. Control functions of AQ-V251.

Name	IEC	ANSI	Description
SGS	-	-	Setting group selection (8 setting groups available)

Name	IEC	ANSI	Description
OBJ	-	-	Object control and monitoring (10 objects available)
CIN	-	-	Indicator object monitoring (10 indicators available)
SOTF	SOTF	-	Switch-on-to-fault
VJP	$\Delta\phi$	78	Vector jump
PCS	-	-	Programmable control switch
SYN	$\Delta V/\Delta a/\Delta f$	25	Synchrocheck function
GSYN	$\Delta V/\Delta a/\Delta f$	25	Synchronizer ( <b>only</b> in Function package B!)

Table. 4.1 - 4. Monitoring functions of AQ-V251.

Name	IEC	ANSI	Description
VTS	-	60	Voltage transformer supervision
DR	-	-	Disturbance recorder
THDV	-	-	Voltage total harmonic distortion
MREC	-	-	Measurement recorder
VREC	-	-	Fault register

## 4.2 Measurements

### 4.2.1 Voltage measurement and scaling

The voltage measurement module (VT module, or VTM) is used for measuring the voltages from voltage transformers. The voltage measurements are updated every 5 milliseconds. The measured values are processed into the measurement database and they are used by measurement and protection functions. It is essential to understand the concept of voltage measurements to be able to get correct measurements.

Figure. 4.2.1 - 2. Voltage measurement terminology

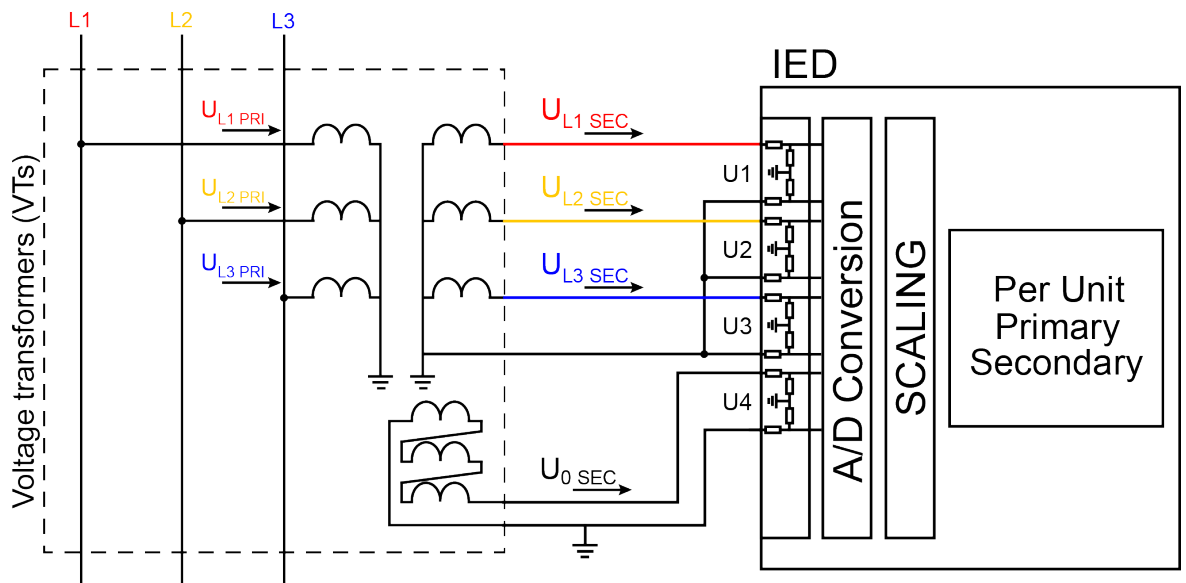

**PRI:** The primary voltage, i.e. the voltage in the primary circuit which is connected to the primary side of the voltage transformer.

**SEC:** The secondary voltage, i.e. the voltage which the voltage transformer transforms according to the ratio. This voltage is measured by the device.

For the measurements to be correct the user needs to ensure that the measurement signals are connected to the correct inputs, that the voltage direction correct, and that the scaling is set correctly.

The device calculates the scaling factors based on the set VT primary, and secondary voltage values. The device measures secondary voltages, which are the voltage outputs from the VT installed into the application's primary circuit. The voltage can be measured directly from the system as well (up to 400 V nominal line to neutral voltage). When connecting voltage directly, measuring mode must be set to 3LN+U4 mode. The rated primary and secondary voltages of the VT need to be set for the device to "know" the primary and per-unit values. In modern protection devices this scaling calculation is done internally after the voltage transformer's primary and secondary voltages are set.

Normally, the primary line-to-line voltage rating for VTs is 400 V...60 kV, while the secondary voltage ratings are 100 V...210 V. Non-standard ratings can also be directly connected as the scaling settings are flexible and have large ranges.

### Example of VT scaling

The following figure presents how VTs are connected to the device's measurement inputs. It also shows the VT ratings. In the figure below, three line-to-neutral voltages are connected along with the zero sequence voltage; therefore, the 3LN+U4 mode must be selected and the U4 channel must be set as U0. Other possible connections are presented later in this chapter.

Figure. 4.2.1 - 3. Connections.

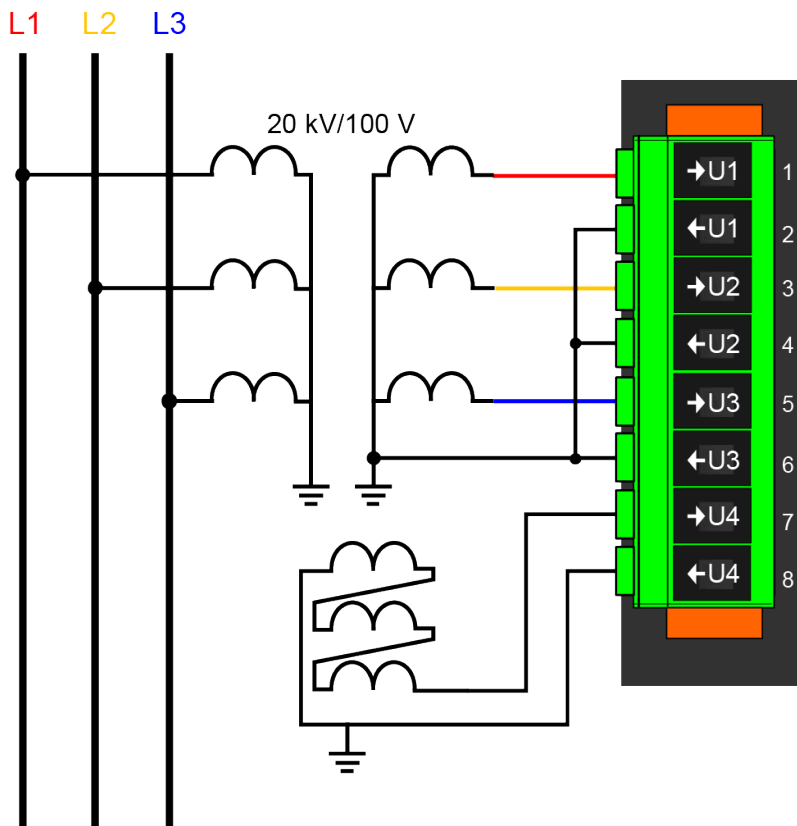

The following table presents the initial data of the connection.

Table. 4.2.1 - 5. Initial data.

<b>Phase voltage VT</b> - VT primary: 20 000 V - VT secondary: 100 V	<b>Zero sequence voltage VT</b> - U4 VT primary: 20 000 V - U4 VT secondary: 100 V
- the zero sequence voltage is connected similarly to line-to-neutral voltages (+U0). - in case wiring is incorrect, all polarities can be individually switched by 180 degrees in the device.	

Once the settings have been sent to the device, device calculates the scaling factors and displays them for the user. The "VT scaling factor P/S" describes the ratio between the primary voltage and the secondary voltage. The per-unit scaling factors ("VT scaling factor p.u.") for both primary and secondary values are also displayed.

There are several different ways to use all four voltage channels. The voltage measurement modes are the following:

- 3LN+U4 (three line-to-neutral voltages and U4 can be used for either zero sequence voltage or synchrochecking)
- 3LL+U4 (three line-to-line voltages and U4 can be used either for zero sequence voltage or synchrochecking)
- 2LL+U3+U4 (two line-to-line voltages and the U3 and the U4 channels can be used for synchrochecking, zero sequence voltage, or for both)

The 3LN+U0 is the most common voltage measurement mode. See below for example connections of voltage line-to-line measurement (3LL on the left, 2LL on the right).

Figure. 4.2.1 - 4. Example connections for voltage line-to-line measurement.

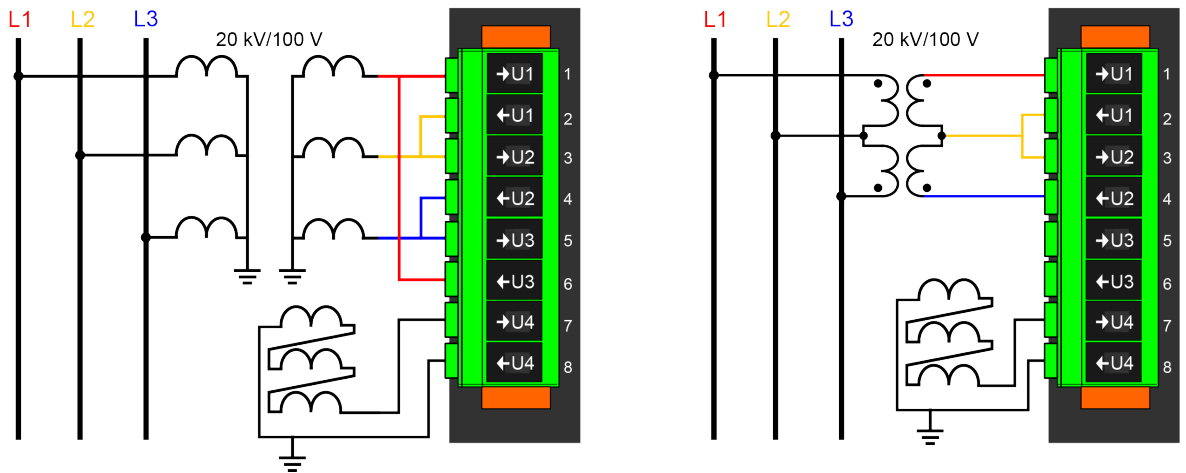

If only two line-to-line voltages are measured, the third one ( $U_{L31}$ ) is calculated based on the  $U_{L12}$  and  $U_{L23}$  vectors. When measuring line-to-line voltages, the line-to-neutral voltages can also be calculated as long as the value of  $U_0$  is measured.

The voltage measurement channel  $U_4$  can be used to measure the zero sequence voltage ( $U_0$ ), the side 2 voltage of the circuit breaker (Synchrocheck), or for automatic voltage regulator function. If the  $2LL+U_3+U_4$  mode is selected, the third channel ( $U_3$ ) can be used for this purpose. Please note that  $U_0$  can only be measured by using a single channel.

In the image below is an example of  $2LL+U_0+SS$ , that is, two line-to-line measurements with the zero sequence voltage and voltage from side 2 for Synchrocheck. Since  $U_0$  is available, line-to-neutral voltages can be calculated.

Figure. 4.2.1 - 5. 2LL+U0+SS settings and connections.

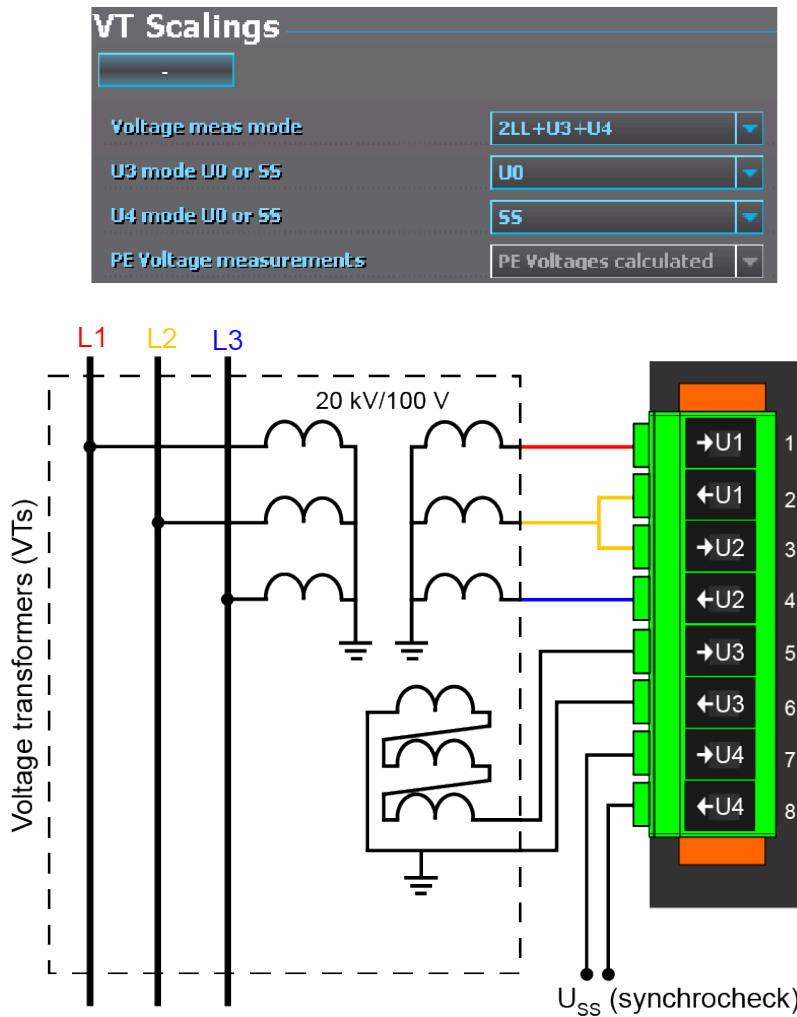

The image collection below presents the device's behavior when nominal voltage is injected into the device via secondary test equipment. The measurement mode is 3LN+U4 which means that the device is measuring line-to-neutral voltages. The VT scaling has been set to 20 000 : 100 V. The U4 channel measures the zero sequence voltage which has the same ratio (20 000 : 100 V).

Figure. 4.2.1 - 6. Measurement behavior when nominal voltage injected.

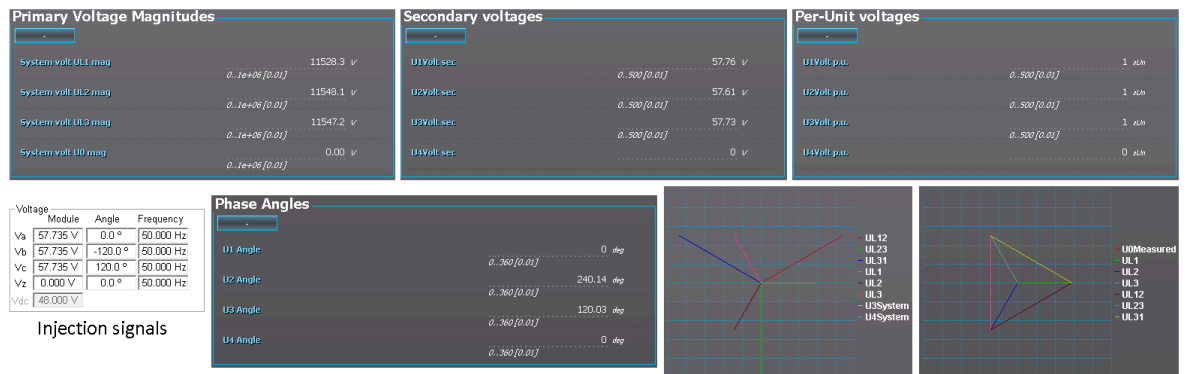

The image collection below presents the device's behavior when voltage is injected into the device via secondary test equipment during an earth fault. The measurement mode is 3LN+U4 which means that the device is measuring line-to-neutral voltages. The VT scaling has been set to 20 000 : 100 V. The U4 channel measures the zero sequence voltage which has the same ratio (20 000 : 100 V).

Figure. 4.2.1 - 7. Device behavior when voltage injected during an earth fault.

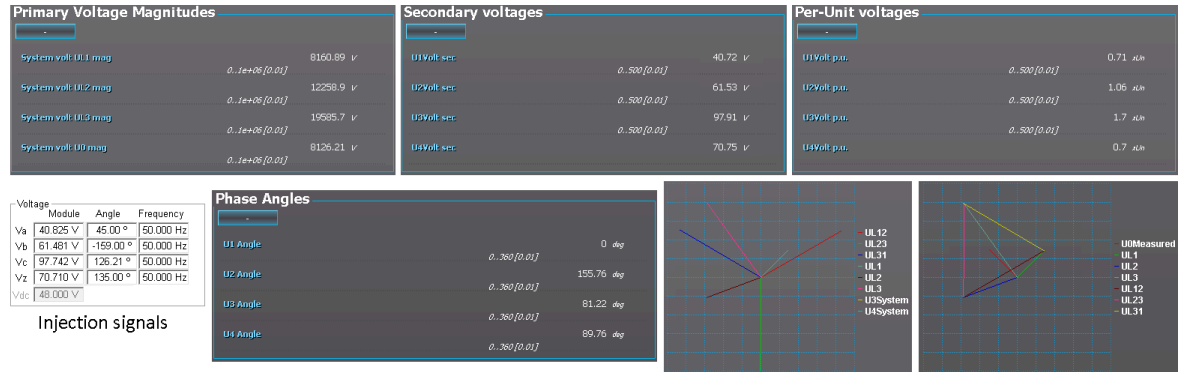

## Troubleshooting

When the measured voltage values differ from the expected voltage values, the following table offers possible solutions for the problems.

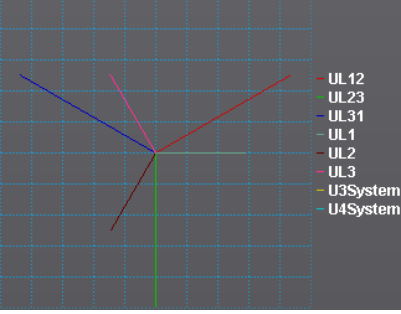
Problem	Check / Resolution
The measured voltage amplitude in all phases does not match the injected voltage.	The scaling settings or the voltage measurement mode may be wrong, check that the settings match with the connected voltage transformer ( <i>Measurement</i> → <i>Transformers</i> → <i>VT Module</i> ).
The measured voltage amplitude does not match one of the measured phases./ The calculated U0 is measured even though it should not.	Check the wiring connections between the injection device or the VTs and the device.
The measured voltage amplitudes are OK but the angles are strange./ The voltage unbalance protection trips immediately after activation./ The earth fault protection trips immediately after it is activated and voltage calculated.	The voltages are connected to the measurement module but the order or polarity of one or all phases is incorrect. In device settings, go to <i>Measurement</i> → <i>Phasors</i> and check the "System voltage vectors" diagram. When all connections are correct, the diagram (symmetric feeding) should look like this: 

## Alternative Settings

Table. 4.2.1 - 6. Settings of the VT scaling.

Name	Range	Step	Default	Description
Voltage measurement mode	<ul style="list-style-type: none"> <li>3LN+U4</li> <li>3LL+U4</li> <li>2LL+U3+U4</li> </ul>	-	3LN+U4	The device's voltage wiring method. The voltages are scaled according the set voltage measurement mode.
U3 mode U0 or SS	<ul style="list-style-type: none"> <li>Not Used</li> <li>U0</li> <li>SS</li> </ul>	-	Not Used	The voltage channel U3 can be used to measure zero sequence voltage (U0) or the Synchrocheck voltage (SS). If neither is needed, the (default) option "Not Used" should be active. This setting is only valid if the "2LL+U3+U4" mode is selected.
U4 mode U0 or SS				The voltage channel U4 can be used to measure zero sequence voltage (U0) or the Synchrocheck voltage (SS). If neither is needed, the (default) option "Not Used" should be active.
U0 (U3) Measured from	<ul style="list-style-type: none"> <li>Broken Delta</li> <li>Neutral point</li> <li>Open delta</li> </ul>	-	Broken delta	Defines how the secondary voltage is scaled to the primary. "Broken Delta" is the most common mode. Does not affect how protection operates, it only affects the displayed primary voltages. This parameter is visible when the "U4 mode U0 or SS" has been set to the "U0" mode. Example with scaling 20000/100 for U <sub>0</sub> and injection 10V secondary: <ul style="list-style-type: none"> <li>Broken delta: 1155V (10%)</li> <li>Neutral point: 2000 V (17.34%)</li> <li>Open delta: 667V (5.78%)</li> </ul>
U0 (U4) Measured from				Defines how the secondary voltage is scaled to the primary. "Broken Delta" is the most common mode. Does not affect how protection operates, it only affects the displayed primary voltages. This parameter is visible when the "U4 mode U0 or SS" has been set to the "U0" mode. Example with scaling 20000/100 for U <sub>0</sub> and injection 10V secondary: <ul style="list-style-type: none"> <li>Broken delta: 1155V (10%)</li> <li>Neutral point: 2000 V (17.34%)</li> <li>Open delta: 667V (5.78%)</li> </ul>
Set input voltage thresholds	<ul style="list-style-type: none"> <li>No</li> <li>Yes</li> </ul>	-	Yes	If this parameter is enabled, it is possible to set minimum voltage required for voltage measurement to start.
U1 input threshold	0.10...50.00 V <sub>sec</sub>	0.01 V <sub>sec</sub>	1.00 V <sub>sec</sub>	Sets the lowest voltage the channel is allowed to measure.
U2 input threshold				
U3 input threshold				
U4 input threshold				

Name	Range	Step	Default	Description
Voltage memory	<ul style="list-style-type: none"> <li>Disabled</li> <li>Activated</li> </ul>	-	Disabled	Activates the voltage memory. The "Voltage memory" chapter describes the function in more detail.
P-E Voltage measurements	<ul style="list-style-type: none"> <li>No P-E voltages available</li> <li>P-E Voltages calculated</li> <li>P-E Voltages measured</li> </ul>	-	-	Indicates whether or not phase-to-earth voltages are available. Also indicates whether P-E voltages are measured from the voltage channels directly or if they are calculated from measured line-to-line and zero sequence voltages.
VT primary	1.0...1 000 000.0V	0.1V	20 000.0V	The rated primary voltage of the voltage transformer.
VT secondary	0.2...400.0V	0.1V	100.0V	The rated secondary voltage of the voltage transformer.
U3 Res/SS VT primary	1.0...1 000 000V	0.1V	20 000.0V	The primary nominal voltage of the connected U0 or SS VT. This setting is only valid if the "2LL+U3+U4" mode is selected.
U3 Res/SS VT secondary	0.2...400.0V	0.1V	100.0V	The secondary nominal voltage of the connected U0 or SS VT. This setting is only valid if the "2LL+U3+U4" mode is selected.
U4 Res/SS VT primary	1.0...1 000 000.0V	0.1V	20 000.0V	The primary nominal voltage of the connected U0 or SS VT.
U4 Res/SS VT secondary	0.2...400.0V	0.1V	100.0V	The secondary nominal voltage of the connected U0 or SS VT.
U1 Polarity	<ul style="list-style-type: none"> <li>-</li> <li>Invert</li> </ul>	-	-	The selection of the first voltage measurement channel's (U1) polarity (direction). The default setting is for the positive voltage to flow from connector 1 to connector 2, with the secondary voltage's starpoint pointing towards the line.
U2 Polarity				The selection of the second voltage measurement channel's (U2) polarity (direction). The default setting is for the positive voltage to flow from connector 3 to connector 4, with the secondary voltage's starpoint pointing towards the line.
U3 Polarity				The selection of the third voltage measurement channel's (U3) polarity (direction). The default setting is for the positive voltage to flow from connector 5 to connector 6, with the secondary voltage's starpoint pointing towards the line.
U4 Polarity				The selection of the fourth voltage measurement channel's (U4) polarity (direction). The default setting is for the positive voltage to flow from connector 7 to connector 8, with the secondary voltage's starpoint pointing towards the line.

Table. 4.2.1 - 7. Read-only parameters of the VT scaling.

Name	Description
VT scaling factor P/S	The calculated scaling factor that is the ratio between the primary voltage and the secondary voltage.
VT scaling factor p.u. Pri	The scaling factor for the primary voltage's per-unit value.
VT scaling factor p.u. Sec	The scaling factor for the secondary voltage's per-unit value.
U3 VT scaling factor P/S U0/SS	The scaling factor that is the ratio between the U3 channel's primary and secondary voltages. This setting is only valid if the "2LL+U3+U4" mode is selected.
U3 scaling factor p.u. Pri	Scaling factor for the primary voltage's per-unit value. This setting is only valid if the "2LL+U3+U4" mode is selected.
U3 scaling factor p.u. Sec	Scaling factor for the secondary voltage's per-unit value. This setting is only valid if the "2LL+U3+U4" mode is selected.
U4 VT scaling factor P/S U0/SS	Scaling factor that is the ration between the U4 channel's primary and secondary voltages. This setting is only valid is the "2LL+U3+U4" mode is selected.
U4 scaling factor p.u. Pri	Scaling factor for the primary voltage's per-unit value. This setting is only valid if the "2LL+U3+U4" mode is selected.
U4 scaling factor p.u. Sec	Scaling factor for the secondary voltage's per-unit value. This setting is only valid if the "2LL+U3+U4" mode is selected.

## Measurements

The following measurements are available in the measured voltage channels.

Table. 4.2.1 - 8. Per-unit voltage measurements.

Name	Range	Step	Description
UxVolt p.u.	0.00...500.00xU <sub>N</sub>	0.01xU <sub>N</sub>	The voltage measurement fundamental frequency component (in p.u.) from each of the voltage channels.
UxVolt TRMS p.u.	0.00...500.00xU <sub>N</sub>	0.01xU <sub>N</sub>	The TRMS voltage (inc. harmonics up to 31 <sup>st</sup> ) measurement (in p.u.) from each of the voltage channels.

Table. 4.2.1 - 9. Secondary voltage measurements.

Name	Range	Step	Description
Ux Volt sec	0.00...500.00V	0.01V	The secondary voltage measurement fundamental frequency component from each of the voltage channels.
UxVolt TRMS sec	0.00...500.00V	0.01V	The secondary TRMS voltage (inc. harmonics up to 31 <sup>st</sup> ) measurement from each of the voltage channels.

Table. 4.2.1 - 10. Voltage phase angle measurements.

Name	Range	Step	Description
Ux Angle	0.00...360.00°	0.01°	The phase angle measurement from each of the four voltage inputs.

Table. 4.2.1 - 11. Per-unit sequence voltage measurements.

Name	Range	Step	Description
Pos.seq.Volt.p.u.	0.00...500.00xU <sub>N</sub>	0.01xU <sub>N</sub>	The measurement (in p.u.) from the calculated positive sequence voltage.
Neg.seq.Volt.p.u.	0.00...500.00xU <sub>N</sub>	0.01xU <sub>N</sub>	The measurement (in p.u.) from the calculated negative sequence voltage.
Zero.seq.Volt.p.u.	0.00...500.00xU <sub>N</sub>	0.01xU <sub>N</sub>	The measurement (in p.u.) from the calculated zero sequence voltage.

Table. 4.2.1 - 12. Primary sequence voltage measurements.

Name	Range	Step	Description
Pos.seq.Volt.pri	0.00...1 000 000.00V	0.01V	The primary measurement from the calculated positive sequence voltage.
Neg.seq.Volt.pri	0.00...1 000 000.00V	0.01V	The primary measurement from the calculated negative sequence voltage.
Zero.seq.Volt.pri	0.00...1 000 000.00V	0.01V	The primary measurement from the calculated zero sequence voltage.

Table. 4.2.1 - 13. Secondary sequence voltage measurements.

Name	Range	Step	Description
Pos.seq.Volt.sec	0.00...4 800.00V	0.01V	The secondary measurement from the calculated positive sequence voltage.
Neg.seq.Volt.sec	0.00...4 800.00V	0.01V	The secondary measurement from the calculated negative sequence voltage.
Zero.seq.Volt.sec	0.00...4 800.00V	0.01V	The secondary measurement from the calculated zero sequence voltage.

Table. 4.2.1 - 14. Sequence voltage angle measurements.

Name	Range	Step	Description
Pos.seq.Volt.Angle	0.00...360.00°	0.01°	The calculated positive sequence voltage angle.
Neg.seq.Volt.Angle	0.00...360.00°	0.01°	The calculated negative sequence voltage angle.
Zero.seq.Volt.Angle	0.00...360.00°	0.01°	The calculated zero sequence voltage angle.

Table. 4.2.1 - 15. System primary voltage measurements.

Name	Range	Step	Description
System volt UL12 mag	0.00...1 000 000.00V	0.01V	The primary line-to-line UL12 voltage fundamental frequency component (measured or calculated). You can also select the row where the unit for this is kV.
System volt UL23 mag	0.00...1 000 000.00V	0.01V	The primary line-to-line UL23 voltage fundamental frequency component (measured or calculated). You can also select the row where the unit for this is kV.
System volt UL31 mag	0.00...1 000 000.00V	0.01V	The primary line-to-line UL31 voltage fundamental frequency component (measured or calculated). You can also select the row where the unit for this is kV.
System volt UL1 mag	0.00...1 000 000.00V	0.01V	The primary line-to-neutral UL1 voltage fundamental frequency component (measured or calculated). You can also select the row where the unit for this is kV.
System volt UL2 mag	0.00...1 000 000.00V	0.01V	The primary line-to-neutral UL2 voltage fundamental frequency component (measured or calculated). You can also select the row where the unit for this is kV.
System volt UL3 mag	0.00...1 000 000.00V	0.01V	The primary line-to-neutral UL3 voltage fundamental frequency component (measured or calculated). You can also select the row where the unit for this is kV.
System volt U0 mag	0.00...1 000 000.00V	0.01V	The primary zero sequence U0 voltage fundamental frequency component (measured or calculated). You can also select the row where the unit for this is kV. There is also a row where the unit is %.
System volt U3 mag	0.00...1 000 000.00V	0.01V	The primary measured Synchrocheck voltage fundamental frequency component (SS). This magnitude is displayed only when the "2LL+U3+U4" mode is selected and both U3 and U4 are in use. You can also select the row where the unit for this is kV.
System volt U4 mag	0.00...1 000 000.00V	0.01V	The primary measured Synchrocheck voltage fundamental frequency component (SS). This magnitude is displayed only when the "2LL+U3+U4" mode is selected and both U3 and U4 are in use. You can also select the row where the unit for this is kV.

Table. 4.2.1 - 16. Primary system voltage angles.

Name	Range	Step	Description
System volt UL12 ang	0.00...360.00°	0.01°	The primary line-to-line angle UL12 (measured or calculated).
System volt UL23 ang	0.00...360.00°	0.01°	The primary line-to-line angle UL23 (measured or calculated).

Name	Range	Step	Description
System volt UL31 ang	0.00...360.00°	0.01°	The primary line-to-line angle UL23 (measured or calculated).
System volt UL1 ang	0.00...360.00°	0.01°	The primary line-to-neutral angle UL1 (measured or calculated).
System volt UL2 ang	0.00...360.00°	0.01°	The primary line-to-neutral angle UL2 (measured or calculated).
System volt UL3 ang	0.00...360.00°	0.01°	The primary line-to-neutral angle UL3 (measured or calculated).
System volt U0 ang	0.00...360.00°	0.01°	The primary zero sequence angle U0 (measured or calculated).
System volt U3 ang	0.00...360.00°	0.01°	The primary measured Synchrocheck angle SS. This magnitude is only valid when the "2LL+U3+U4" mode is selected and both U3 and U4 are in use.
System volt U4 ang	0.00...360.00°	0.01°	The primary measured Synchrocheck angle SS. This magnitude is displayed only when the "2LL+U3+U4" mode is selected and both U3 and U4 are in use.

Table. 4.2.1 - 17. Harmonic voltage measurements.

Name	Range	Step	Description
Harm Abs.or Perc.	<ul style="list-style-type: none"> <li>Percent</li> <li>Absolute</li> </ul>	-	Defines whether the harmonics are calculated as percentages or absolute values.
Harmonics display	<ul style="list-style-type: none"> <li>Per unit</li> <li>Primary V</li> <li>Secondary V</li> </ul>	-	Defines how the harmonics are displayed: in p.u. values, as primary voltage values, or as secondary voltage values.
UxMaxH	0.00...100 000.00V	0.01V	Displays the maximum harmonics value of the selected voltage input Ux.
Ux Fund	0.00...100 000.00V	0.01V	Displays the voltage value of the fundamental frequency component of the selected voltage input Ux.
Ux harmonics (2 <sup>nd</sup> ...31 <sup>st</sup> harmonic)	0.00...100 000.00V	0.01V	Displays the selected harmonic from the voltage input Ux.
Ux Amplitude THD	0.000...100.000V	0.001V	Amplitude ratio THD voltage. Recognized by IEC.
Ux Power THD	0.000...100.000V	0.001V	Power ratio THD voltage. Recognized by the IEEE.

## Voltage memory

Some protection functions (such as directional overcurrent) use the device's measured current and voltage to determine whether the electrical network fault appears to be inside the protected area. The determination is made by comparing the angle between the operating quantity (zone/tripping area) and the actual measured quantity. The function then produces an output when the required terms are met.

In close-in faults the system voltage on the secondary side may fall down to a few volts or close to nothing. In such cases, when the measured voltage is absent, the fault direction cannot be solved. As a backup, non-directional protection can be used for tripping, but in such cases the selectivity of the network will be reduced. However, an angle memory for voltage can be used to prevent this from happening. An adjustable voltage level with pre-fault voltage angles can be used as a reference for fault direction and/or distance. The reference can be set manually for duration. Configurable voltage memory enables even time-delayed backup tripping to be initiated.

The user can activate voltage memory (and find all related settings) by following this path in device settings: *Measurement* → *Transformers* → *VT Module (3U/4U) 1* → *Voltage memory* ("Activated"/"Disabled").

The activation of voltage memory depends of following criteria:

1. Normal voltage levels have been present for longer than 2.5 seconds before voltages have dropped.
2. All used line-to-line or line-to-neutral voltages need to be below the set value for the "VMEM activation voltage" parameter.
3. At least one phase current must be above the set value for the "Measured current condition 3I>" parameter. This setting limit is optional.

Figure. 4.2.1 - 8. Directional overcurrent characteristics.

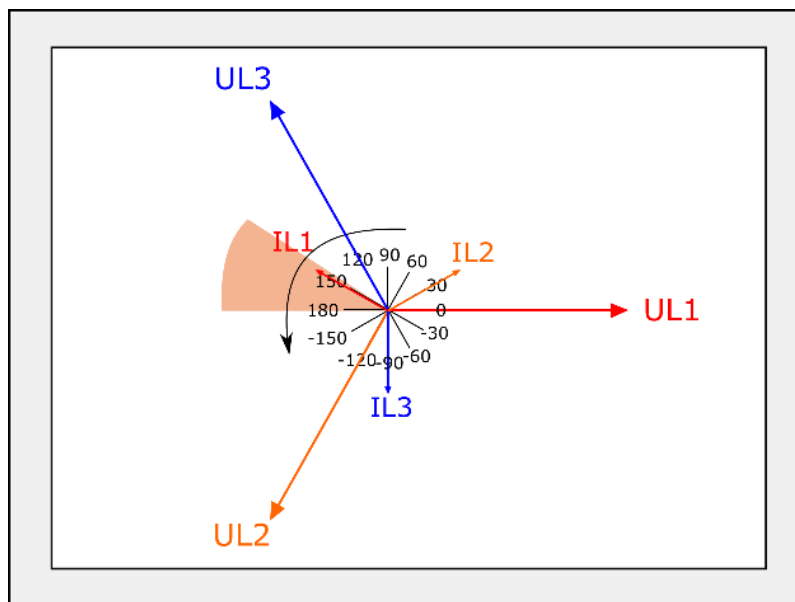

Voltage memory activates when the above-mentioned criteria are met. Voltage memory uses the "VMEM activation voltage" parameter as voltage amplitude even when the actual measured voltage has decreased below it or close to zero. The angle used by this function is the one captured the moment before the fault occurred and voltage memory was activated. When voltage memory is activated, the output "Voltage memory on" signal is activated. This signal can be found in the device's I/O matrix.

While voltage memory is active, voltages are absent and therefore angle measurement is not possible. Healthy state angles (before a fault) are used during a fault. This is why a drift between the assumed voltage angle and the actual measured phase current angle takes place. While voltage memory is used, the angle of phase currents drifts approximately one degree for each passing second (see the graph below).

Figure. 4.2.1 - 9. Voltage angle drift.

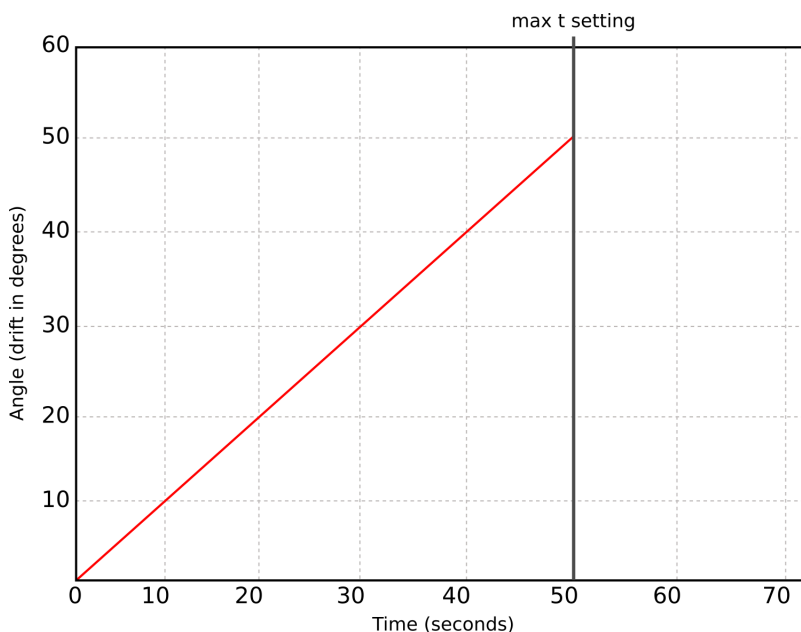

The blocking signal for voltage memory can be found among other stage-related settings in the tab *VT Module (3U/4U) 1*. The blocking signal is checked in the beginning of each program cycle.

**VMEM activation voltage and Measured current condition 3I>**

When the voltage memory function is enabled, it activates when all line voltages drop below the "VMEM activation voltage" threshold limit. When "Measured current condition 3I>" is used, activation cannot be based on just the voltage. Therefore, at least one of the three-phase currents must also rise above the set current pick-up setting.

**VMEM max active time**

Voltage memory can be active for a specific period of time, set in "VMAX active time". It can be anything between 0.02...50.00 seconds. The function supports the definite time (DT) delay type. It depends on the application for how long the memory should be used. During massive bolted faults, the fault should be cleared and the breaker opened as soon as possible; therefore, a short operating time for voltage memory is usually applied. A typical delay for voltage memory is between 0.5...1.0 s. When the operating time passes and voltage memory is no longer used, the protection function operation is blocked and possible START or TRIP signals are reset. The memory uses longer operating times when a backup protection is applied.

**Forced CT f tracking on VMEM**

While fixed frequency tracking is used, all protection stage-based sampling (apart from frequency protection) is based on a set fixed frequency such as 50 Hz or 60 Hz. When the frequency drops massively during a fault while angle memory is in use, it is also possible that the frequency of the system starts to fluctuate. In such cases, if current sampling of used protection stages is based on 50/60 Hz, there could be an error in current magnitude and in angle measurement. To minimize these errors, it is recommended that the frequency is measured and protection-based sampling from the current is performed while voltages are gone.

When the "Forced CT f tracking" parameter is activated and voltages are gone, the frequency from the selected current-based reference channel 3 (the current from IL3) is used for current sampling. This eliminates any possible measurement errors in the fixed frequency mode.

For example, let us say a 500 A current is measured on the primary side while the fixed frequency is set to 50 Hz. This results in the frequency dropping to 46 Hz, while the actual current measurement would be 460 A. Therefore, the system would have an error of 40 A.

Table. 4.2.1 - 18. Voltage memory parameters.

Name	Range	Step	Default	Description
Voltage memory	<ul style="list-style-type: none"> <li>Disabled</li> <li>Activated</li> </ul>	-	Enabled	Enables or activates voltage memory function.
VMEM activation voltage	0.10...50.00 %Un	0.01 %Un	15.00 %Un	Voltage threshold for activating voltage memory. When all voltage measurements are under this setting value, voltage memory is activated.
VMEM max active time	0.020...50.000 s	0.005 s	15.000 s	Maximum duration for voltage memory. After the time set in this parameter has passed, voltage memory is reset.
Enable forced CT f tracking on VMEM	<ul style="list-style-type: none"> <li>Disabled</li> <li>Activated</li> </ul>	-	Disabled	When in use, frequency tracking is forced to "reference 3" when no voltage can be measured. If this parameter is used, frequency reference 3 should be set to "IL3".
Forced CT tracking status	<ul style="list-style-type: none"> <li>Disabled</li> <li>Activated</li> </ul>	-	-	Displays the current status of the "forced CT tracking".
Measured current condition 3I>	<ul style="list-style-type: none"> <li>Disabled</li> <li>Activated</li> </ul>	-	Disabled	Enables or activates current condition monitoring. When in use, at least one of the phase currents must rise above a set value for the voltage memory to activate.
Minimum current for VMEM	0.01...50.00 xIn	0.01 xIn	1.00 xIn	Minimum required current for current condition.
Current condition status	<ul style="list-style-type: none"> <li>Disabled</li> <li>Activated</li> </ul>	-	-	Displays the current monitoring status.

Table. 4.2.1 - 19. Voltage memory event messages.

Event block name	Event names
M1VT1	Voltage memory enabled/disabled
M1VT1	Voltage low detected ON/OFF
M1VT1	Current high detected ON/OFF
M1VT1	Frequency tracked from CT ON/OFF
M1VT1	Using Voltage memory ON/OFF
M1VT1	Voltage memory blocked ON/OFF

## 4.2.2 Frequency tracking and scaling

Measurement sampling can be set to the frequency tracking mode or to the fixed user-defined frequency sampling mode. The benefit of frequency tracking is that the measurements are within a pre-defined accuracy range even when the fundamental frequency of the power system changes.

Table. 4.2.2 - 20. Frequency tracking effect (FF changes from 6 Hz to 75 Hz).

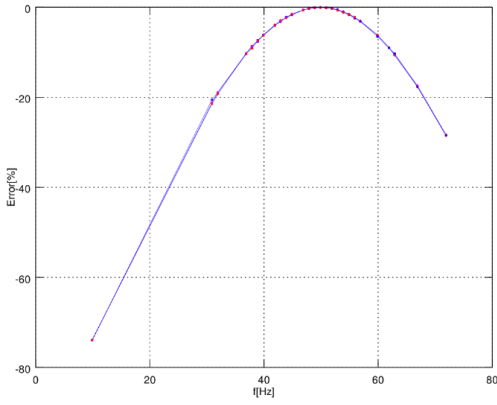
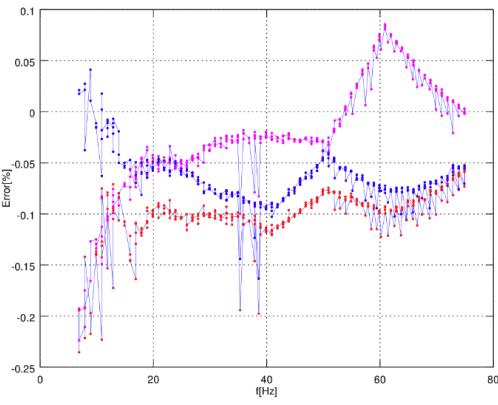
	
<p>The measurement error with a fixed 50 Hz sampling frequency when the frequency changes. The constant current is 5 A, the frequency sweep is from 6 Hz to 75 Hz.</p>	<p>The measurement error with frequency tracking when the frequency changes. The constant current is 5 A, the frequency sweep is from 6 Hz to 75 Hz.</p>

As the figures above show, the sampling frequency has a major effect on the device's measurement accuracy. If the sampling is not tracked to the system frequency, for example a 10 Hz difference between the measured and the set system frequency can give a measurement error of over 5 %. The figures also show that when the frequency is tracked and the sampling is adjusted according to the detected system frequency, the measurement accuracy has an approximate error of 0.1...- 0.2 % error in the whole frequency range.

The device has a measurement accuracy that is independent of the system frequency. This has been achieved by adjusting the sample rate of the measurement channels according to the measured system frequency; this way the FFT calculation always has a whole power cycle in the buffer. The measurement accuracy is further improved by Arcteq's patented calibration algorithms that calibrate the analog channels against eight (8) system frequency points for both magnitude and angle. This frequency-dependent correction compensates the frequency dependencies in the used, non-linear measurement hardware and improves the measurement accuracy significantly. Combined, these two methods give an accurate measurement result that is independent of the system frequency.

## Troubleshooting

When the measured current, voltage or frequency values differ from the expected values, the following table offers possible solutions for the problems.

Problem	Check / Resolution
<p>The measured current or voltage amplitude is lower than it should be./ The values are "jumping" and are not stable.</p>	<p>The set system frequency may be wrong. Please check that the frequency settings match the local system frequency, or change the measurement mode to "Tracking" (<i>Measurement</i> → <i>Frequency</i> → "Sampling mode") so the device adjusts the frequency itself.</p>

Problem	Check / Resolution
The frequency readings are wrong.	In Tracking mode the device may interpret the frequency incorrectly if no current is injected into the CT (or voltage into the VT). Please check the frequency measurement settings ( <i>Measurement</i> → <i>Frequency</i> ).

## Settings

Table. 4.2.2 - 21. Settings of the frequency tracking.

Name	Range	Step	Default	Description
Sampling mode	<ul style="list-style-type: none"> <li>Fixed</li> <li>Tracking</li> </ul>	-	Fixed	Defines which measurement sampling mode is in use: the fixed user-defined frequency, or the tracked system frequency.
System nominal frequency	7.000...75.000Hz	0.001Hz	50Hz	The user-defined system nominal frequency that is used when the "Sampling mode" setting has been set to "Fixed".
Tracked system frequency	0.000...75.000Hz	0.001Hz	-	Displays the rough measured system frequency.
Sampling frequency in use	0.000...75.000Hz	0.001Hz	-	Displays the tracking frequency that is in use at that moment.
Frequency reference 1	<ul style="list-style-type: none"> <li>None</li> <li>CT1IL1</li> <li>CT2IL1</li> <li>VT1U1</li> <li>VT2U1</li> </ul>	-	CT1IL1	The first reference source for frequency tracking.
Frequency reference 2	<ul style="list-style-type: none"> <li>None</li> <li>CT1IL2</li> <li>CT2IL2</li> <li>VT1U2</li> <li>VT2U2</li> </ul>	-	CT1IL2	The second reference source for frequency tracking.
Frequency reference 3	<ul style="list-style-type: none"> <li>None</li> <li>CT1IL3</li> <li>CT2IL3</li> <li>VT1U3</li> <li>VT2U3</li> </ul>	-	CT1IL3	The third reference source for frequency tracking.

Name	Range	Step	Default	Description
Frequency tracking quality	<ul style="list-style-type: none"> <li>No trackable channels</li> <li>Reference 1 trackable</li> <li>Reference 2 trackable</li> <li>References 1 &amp; 2 trackable</li> <li>Reference 3 trackable</li> <li>Reference 1 &amp; 3 trackable</li> <li>References 2 &amp; 3 trackable</li> <li>All references trackable</li> </ul>	-	-	Defines the frequency tracker quality. If the measured current (or voltage) amplitude is below the threshold, the channel tracking quality is 0 and cannot be used for frequency tracking. If all channels' magnitudes are below the threshold, there are no trackable channels.
Frequency measurement in use	<ul style="list-style-type: none"> <li>No track ch</li> <li>Ref1</li> <li>Ref2</li> <li>Ref3</li> </ul>	-	-	Indicates which reference is used at the moment for frequency tracking.
Start behavior	<ul style="list-style-type: none"> <li>Start tracking immediately</li> <li>First nominal or tracked</li> </ul>	-	Start tracking immediately	Defines the how the tracking starts. Tracking can start immediately, or there can be a set delay time between the receiving of the first trackable channel and the start of the tracking.
Start sampling with	<ul style="list-style-type: none"> <li>Use track frequency</li> <li>Use nom frequency</li> </ul>	-	Use track frequency	Defines the start of the sampling. Sampling can begin with a previously tracked frequency, or with a user-set nominal frequency.
Use nominal frequency until	0...1800.000s	0.005s	0.100s	Defines how long the nominal frequency is used after the tracking has started. This setting is only valid when the "Sampling mode" setting is set to "Tracking" and when the "Start behavior" is set to "First nominal or tracked".
Tracked f channel A	0.000...75.000Hz	0.001Hz	-	Displays the rough value of the tracked frequency in Channel A.
Tracked f channel B	0.000...75.000Hz	0.001Hz	-	Displays the rough value of the tracked frequency in Channel B.
Tracked f channel C	0.000...75.000Hz	0.001Hz	-	Displays the rough value of the tracked frequency in Channel C.
System measured frequency	<ul style="list-style-type: none"> <li>One f measured</li> <li>Two f measured</li> <li>Three f measured</li> </ul>	-	-	Displays the amount of frequencies that are measured.
f.atm. Protections	0.000...75.000Hz	0.001Hz	-	Frequency measurement value used by protection functions. When frequency is not measurable this value returns to value set to "System nominal frequency" parameter.

Name	Range	Step	Default	Description
f.atm. Display	0.000...75.000Hz	0.001Hz	-	Frequency measurement value used in display. When frequency is not measurable this value is "0 Hz".
f measurement from	<ul style="list-style-type: none"> <li>• Not measurable</li> <li>• Avg Ref 1</li> <li>• Avg Ref 2</li> <li>• Avg Ref 3</li> <li>• Track Ref 1</li> <li>• Track Ref 2</li> <li>• Track Ref 3</li> <li>• Fast Ref 1</li> <li>• Fast Ref 2</li> <li>• Fast Ref 3</li> </ul>	-	-	Displays which reference is used for frequency measurement.
SS1.meas.frqs	0.000...75.000Hz	0.001Hz	-	Displays frequency used by "system set" channel 1 and 2.
SS2.meas.frqs				
SS1f meas.from	<ul style="list-style-type: none"> <li>• Not measurable</li> <li>• Fast Ref U3</li> <li>• Fast Ref U4</li> </ul>	-	-	Displays which voltage channel frequency reference is used by "system set" voltage channel.
SS2f meas.from	<ul style="list-style-type: none"> <li>• Not measurable</li> <li>• Fast Ref U4</li> </ul>	-	-	Displays if U4 channel frequency reference is measurable or not when the channel has been set to "system set" mode.

### 4.3 General menu

The *General* menu consists of basic settings and indications of the device. Additionally, the all activated functions and their status are displayed in the *Protection*, *Control* and *Monitor* profiles.

Table. 4.3 - 22. The *General* menu read-only parameters

Name	Description
Serial number	The unique serial number identification of the unit.
Firmware version	The firmware software version of the unit.
Hardware configuration	The order code identification of the unit.
System phase rotating order at the moment	The selected system phase rotating order. Can be changed with parameter "System phase rotating order".
UTC time	The UTC time value which the device's clock uses.

Table. 4.3 - 23. Parameters and indications in the *General* menu.

Name	Range	Default	Description
Device name	-	Unitname	The file name uses these fields when loading the .aqs configuration file from the device.

Name	Range	Default	Description
Device location	-	Unitlocation	
Enable stage forcing	<ul style="list-style-type: none"> <li>Disabled</li> <li>Enabled</li> </ul>	Disabled	When this parameter is enabled it is possible for the user to force the protection, control and monitoring functions to different statuses like START and TRIP. This is done in the function's <i>Info</i> page with the <i>Force status to</i> parameter.
Allow setting of device mode	<ul style="list-style-type: none"> <li>Prohibited</li> <li>From HMI/setting tool only</li> <li>Allowed</li> </ul>	Prohibited	Allows global mode to be modified from setting tool, HMI and IEC61850. Prohibited: Cannot be changed. From HMI/setting tool only: Can only be changed from the setting tool or HMI Allowed: Can be changed from the setting tool, HMI, and IEC 61850 client.
Allow setting of individual LN mode	<ul style="list-style-type: none"> <li>Prohibited</li> <li>From HMI/setting tool only</li> <li>Allowed</li> </ul>	Prohibited	Allow local modes to be modified from setting tool, HMI and IEC61850. Prohibited: Cannot be changed. From HMI/setting tool only: Can only be changed from the setting tool or HMI Allowed: Can be changed from the setting tool, HMI, and IEC 61850 client.
System phase rotating order	<ul style="list-style-type: none"> <li>A-B-C</li> <li>A-C-B</li> </ul>	A-B-C	Allows the user to switch the expected order in which the phase measurements are wired to the unit.
Language	<ul style="list-style-type: none"> <li>User defined</li> <li>English</li> <li>Finnish</li> <li>Chinese</li> <li>Spanish</li> <li>French</li> <li>German</li> <li>Russian</li> <li>Ukrainian</li> <li>Kazakh</li> </ul>	English	Changes the language of the parameter descriptions in the HMI. If the language has been set to "Other" in the settings of the AQtivate setting tool, AQtivate follows the value set into this parameter.
AQtivate ethernet port	<ul style="list-style-type: none"> <li>All</li> <li>COM A</li> <li>Double Ethernet card</li> </ul>	All	If the device has a double Ethernet option card it is possible to choose which ports are available for connecting with AQtivate software.
Clear events	<ul style="list-style-type: none"> <li>-</li> <li>Clear</li> </ul>	-	Clears the event history recorded in the device.
Display brightness	0...8	4	Changes the display brightness. Brightness level 0 turns the display off.
Display sleep timeout	0...3600s	0s	If no buttons are pressed after a set time, the display changes the brightness to whatever is set on the "Display sleep brightness" parameter. If set to 0 s, this feature is not in use. When the device is in sleep mode, all button actions are disabled. Pressing any of the buttons on the front panel will wake up the display, which enables the buttons again.

Name	Range	Default	Description
Display sleep brightness	0...8	0	Defines the brightness of the display when the set display sleep timeout has elapsed. The brightness level "0" turns the display off.
Return to default view	0...3600s	0s	If the user navigates to a menu and gives no input after a period of time defined with this parameter, the unit automatically returns to the default view. If set to 0 s, this feature is not in use.
LED test	<ul style="list-style-type: none"> <li>-</li> <li>Activated</li> </ul>	-	When activated, all LEDs are lit up. LEDs with multiple possible colors blink each color.
HMI restart	<ul style="list-style-type: none"> <li>-</li> <li>Restart</li> </ul>	-	When activated, display restarts.
Display color theme	<ul style="list-style-type: none"> <li>Light theme</li> <li>Dark theme</li> </ul>	Light theme	Defines the color theme used in the HMI.
Reset latches	<ul style="list-style-type: none"> <li>-</li> <li>Reset</li> </ul>	-	Resets the latched signals in the logic and the matrix. When a reset command is given, the parameter automatically returns back to "-".
Measurement recorder	<ul style="list-style-type: none"> <li>Disabled</li> <li>Enabled</li> </ul>	Disabled	Enables the measurement recorder tool, further configured in <i>Tools</i> → <i>Misc</i> → <i>Measurement recorder</i> .
I/O default object selection	<ul style="list-style-type: none"> <li>OBJ1</li> <li>OBJ2</li> <li>OBJ3</li> <li>OBJ4</li> <li>OBJ5</li> <li>OBJ6</li> <li>OBJ7</li> <li>OBJ8</li> <li>OBJ9</li> <li>OBJ10</li> </ul>	OBJ1	"I" and "O" push buttons on the front panel of the device have an indication LED. This parameter defines which objects' status push buttons follow when lighting up the LEDs.
Device Mode	<ul style="list-style-type: none"> <li>On</li> <li>Blocked</li> <li>Test</li> <li>Test/Blocked</li> <li>Off</li> </ul>	On	Set mode of device block. This parameter is visible only when <i>Allow setting of device mode</i> is enabled in <i>General</i> menu.
Reconfigure mimic	<ul style="list-style-type: none"> <li>-</li> <li>Reconfigure</li> </ul>	-	Reloads the mimic to the unit.

Table. 4.3 - 24. General menu logical inputs.

Name	Description
Reset last fault registers	Signal set to this point can be used for resetting latest recorded fault register.
Reset latches	Signals set to this point can be used for resetting latched signals. An alternative to using the "Back" button on the front panel of the device.
Ph.Rotating Logic control 0=A-B-C, 1=A-C-B	Signals set to this point can be used for switching the expected phase rotating order.

## 4.4 Protection functions

### 4.4.1 General properties of a protection function

The following flowchart describes the basic structure of any protection function. The basic structure is composed of analog measurement values being compared to the pick-up values and operating time delay characteristics.

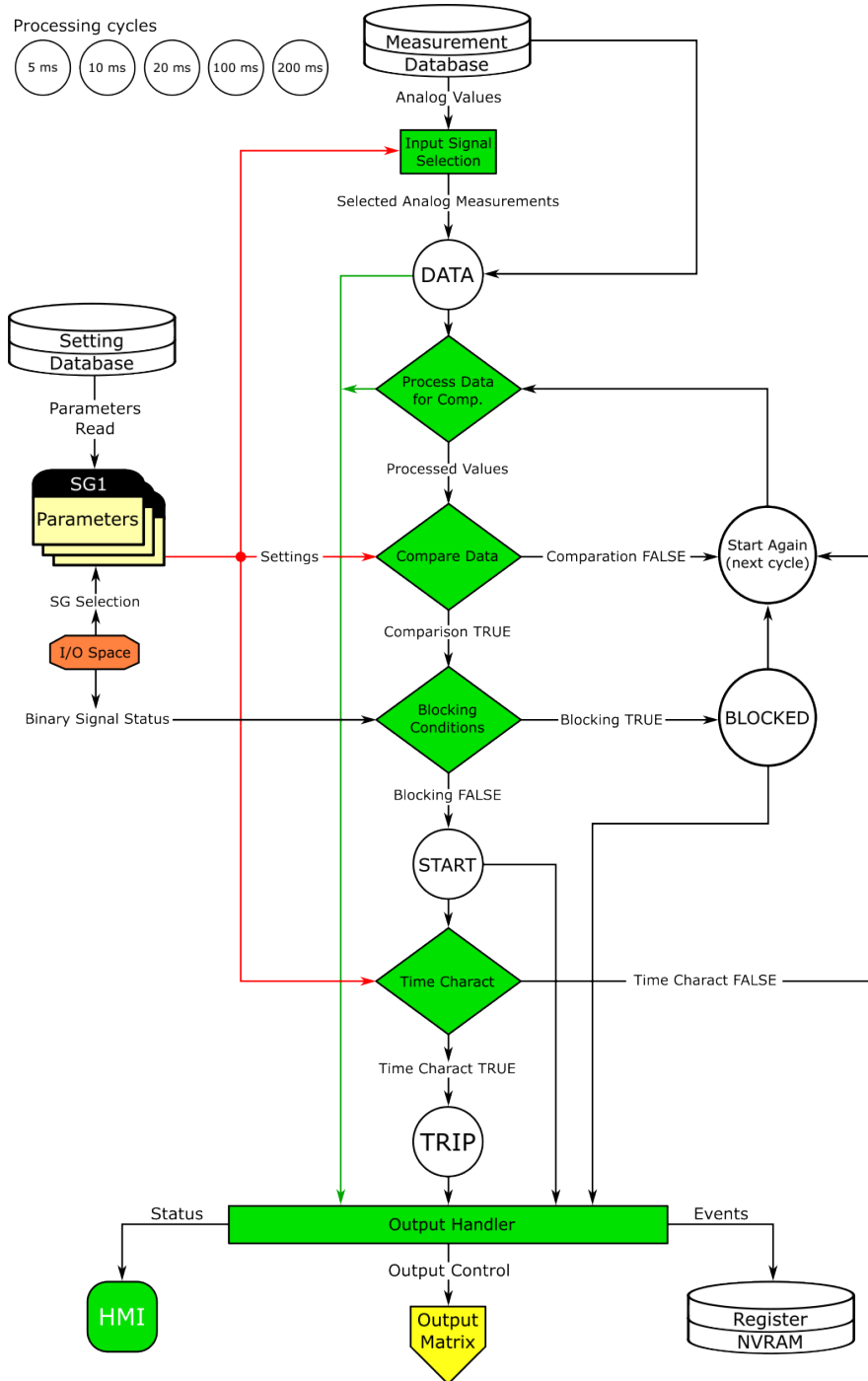

The protection function is run in a completely digital environment with a protection CPU microprocessor which also processes the analog signals transformed into the digital form.

In the following chapters the common functionalities of protection functions are described. If a protection function deviates from this basic structure, the difference is described in the corresponding chapter of the manual.

### Pick-up

The  $X_{set}$  parameter defines the pick-up level of the function, and this in turn defines the maximum or minimum allowed measured magnitude (in per unit, absolute or percentage value) before the function takes action. The function constantly calculates the ratio between the pick-up parameter set by the user and the measured magnitude ( $X_m$ ). The reset ratio of 97 % is built into the function and is always relative to the  $X_{set}$  value. If a function's pick-up characteristics vary from this description, they are defined in the function section in the manual.

Figure. 4.4.1 - 10. Pick up and reset.

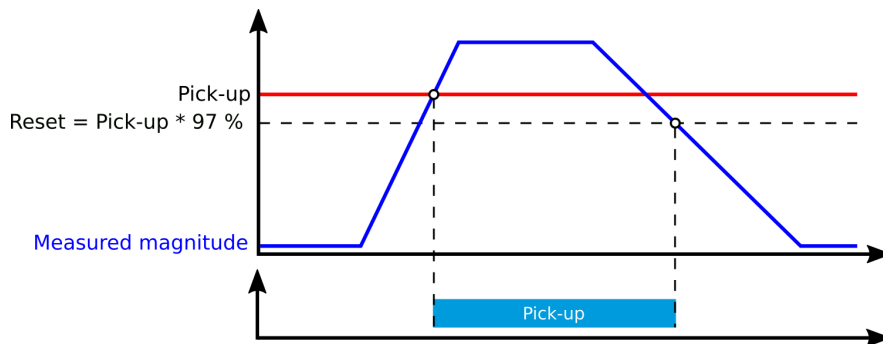
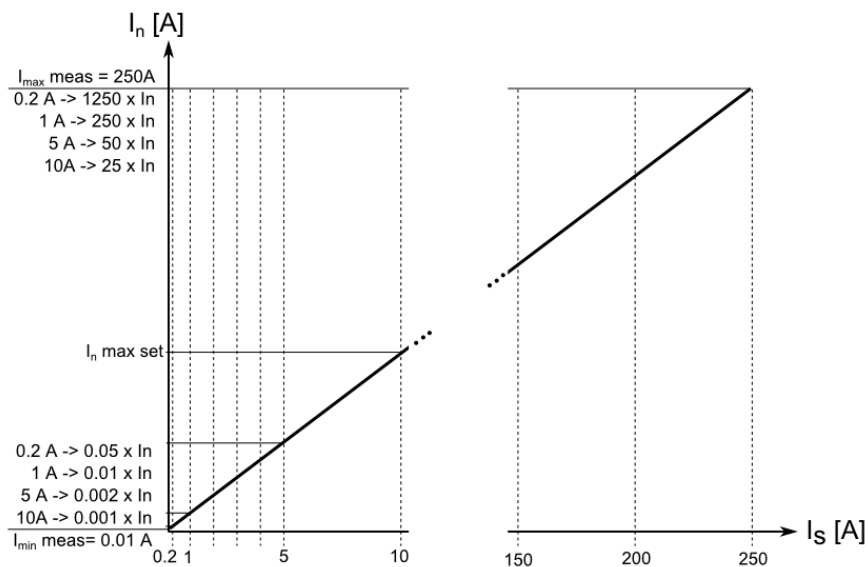

Figure. 4.4.1 - 11. Measurement range in relation to the nominal current.



The  $I_n$  magnitude refers to the user set nominal current which can range from 0.2...10 A, typically 0.2 A, 1A or 5 A. With its own current measurement card, the device will measure secondary currents from 0.001 A up to 250 A. To this relation the pick-up setting in secondary amperes will vary.

### Function blocking

The blocking signal is evaluated at the start of each program cycle. The blocking signals are connected to the function's dedicated input, which can be configured in the *IO* → *Blocking Input Control* tab of the function.

- When the pick-up element activates and the blocking signal is not active, a START signal is generated, and the function starts or continues with the trip time countdown.
- When the pick-up element activates and the blocking signal is active, a BLOCKED signal is generated, and the function does not process the event further.
- When a START signal is already active and the blocking input signal becomes active, the START signal is reset and BLOCKED signal is generated. The release time characteristics are then processed in the same way as when the pick-up signal is reset.

The blocking signal needs to reach the device minimum of 5 ms before the set operating delay has passed in order for the blocking to activate in time. Blocking of the function causes a time stamped blocking event with information of the startup current values and its fault type to be issued.

Some functions also offer an optional internal inrush harmonic blocking feature. If the inrush harmonic pick-up is active at the same time as the protection function pick-up element, the trip delay timer continues counting down as normal. Once the countdown reaches zero, if the pick-up element remains active and the second harmonic value has dropped, the function issues a trip.

Table. 4.4.1 - 25. Internal inrush harmonic blocking settings.

Name	Range	Step	Default	Description
Inrush harmonic blocking (internal-only trip)	<ul style="list-style-type: none"> <li>• No</li> <li>• Yes</li> </ul>	-	<ul style="list-style-type: none"> <li>• No</li> </ul>	Enables and disables the 2 <sup>nd</sup> harmonic blocking.
2 <sup>nd</sup> harmonic blocking limit (I <sub>harm</sub> /I <sub>fund</sub> )	0.10...50.00%I <sub>fund</sub>	0.01%I <sub>fund</sub>	0.01%I <sub>fund</sub>	Defines the limit of the 2 <sup>nd</sup> harmonic blocking.

## Operating time characteristics

Three basic modes are available for delaying function operation:

- Instant operation: activates the trip signal simultaneously with the start signal with no additional time delay.
- Definite time operation (DT): activates the trip signal after a user-defined time delay regardless of the magnitude of the measured value(s) as long as the pick-up element is active.
- Inverse definite minimum time (IDMT): activates the trip signal after a time which is in relation to the set pick-up value and the measured value.

Both IEC and IEEE/ANSI standard characteristics as well as user settable parameters are available for the IDMT operation. Please note that in the IDMT mode *Definite (minimum) operating time delay* also determines the minimum time for protection tripping (see the figure below). If this function is not desired the parameter should be set to 0 seconds.

Figure. 4.4.1 - 12. Operating time delay: *Definite (minimum) operating time delay* and the minimum for tripping.

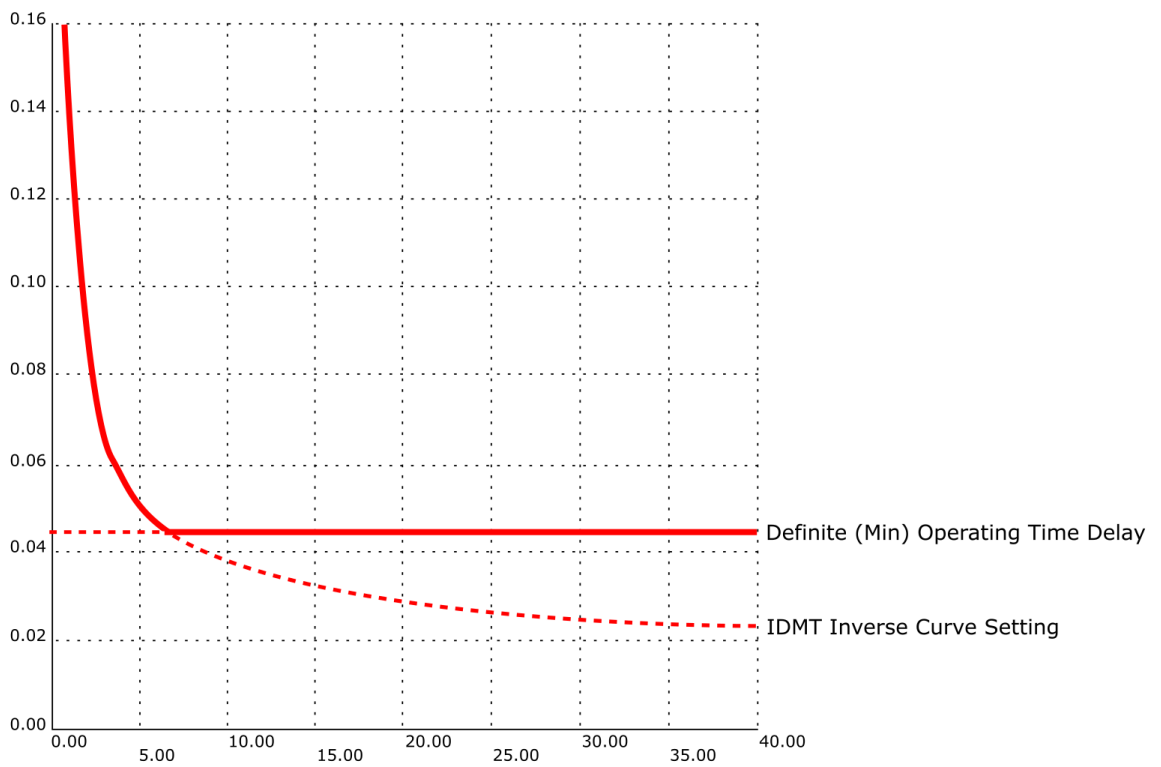

Table. 4.4.1 - 26. Operating time characteristics setting parameters (general).

Name	Range	Step	Default	Description
Delay type	<ul style="list-style-type: none"> <li>DT</li> <li>IDMT</li> </ul>	-	DT	Selects the delay type for the time counter. The selection is made between "Inverse definite minimum time" (IDMT) and "Definite time operation" (DT) characteristics.
Definite (minimum) operating time delay	0.000...1800.000s	0.005s	0.040s	When the "Delay type" parameter is set to "DT", this parameter acts as the expected operating time for the protection function. When set to 0 s, the stage operates instantaneously without any additional delay. When the parameter is set to 0.005...1800 s, the stage operates as independent delayed. When the "Delay type" parameter has been set to "IDMT", this parameter can be used to determine the minimum operating time for the protection function. Example of this is presented in the figure above.
Delay curve series	<ul style="list-style-type: none"> <li>IEC</li> <li>IEEE</li> </ul>	-	IEC	Selects whether the delay curve series for an IDMT operation follows either IEC or IEEE/ANSI standard defined characteristics. This setting is active and visible when the "Delay type" parameter is set to "IDMT".

Name	Range	Step	Default	Description
Delay characteristics IEC	<ul style="list-style-type: none"> <li>• NI</li> <li>• EI</li> <li>• VI</li> <li>• LTI</li> <li>• Param</li> </ul>	-	NI	<p>Selects the IEC standard delay characteristics. The options include the following: Normally Inverse ("NI"), Extremely Inverse ("EI"), Very Inverse ("VI") and Long Time Inverse ("LTI") characteristics. Additionally, the "Param" option allows the tuning of the constants A and B which then allows the setting of characteristics following the same formula as the IEC curves mentioned here.</p> <p>This setting is active and visible when the "Delay type" parameter is set to "IDMT" and the "Delay curve series" parameter is set to "IEC".</p>
Delay characteristics IEEE	<ul style="list-style-type: none"> <li>• ANSI NI</li> <li>• ANSI VI</li> <li>• ANSI EI</li> <li>• ANSI LTI</li> <li>• IEEE MI</li> <li>• IEEE VI</li> <li>• IEEE EI</li> <li>• Param</li> </ul>	-	ANSI NI	<p>Selects the IEEE and ANSI standard delay characteristics. The options for ANSI include the following: Normal Inverse ("ANSI NI"), Very Inverse ("ANSI VI"), Extremely inverse ("ANSI EI"), Long time inverse ("ANSI LTI") characteristics. IEEE: Moderately Inverse ("IEEE MI"), Very Inverse ("IEEE VI"), Extremely Inverse ("IEEE EI") characteristics. Additionally, the "Param" option allows the tuning of the constants A, B and C which then allows the setting of characteristics following the same formula as the IEEE curves mentioned here.</p> <p>This setting is active and visible when the "Delay type" parameter is set to "IDMT" and the "Delay curve series" parameter is set to "IEEE".</p>
Time dial setting k	0.01...25.00s	0.01s	0.05s	<p>Defines the time dial/multiplier setting for IDMT characteristics. This setting is active and visible when the "Delay type" parameter is set to "IDMT".</p>
A	0.0000...250.0000	0.0001	0.0860	<p>Defines the Constant A for IEC/IEEE characteristics. This setting is active and visible when the "Delay type" parameter is set to "IDMT" and the "Delay characteristic" parameter is set to "Param".</p>
B	0.0000...250.0000	0.0001	0.1850	<p>Defines the Constant B for IEC/IEEE characteristics. This setting is active and visible when the "Delay type" parameter is set to "IDMT" and the "Delay characteristic" parameter is set to "Param".</p>
C	0.0000...250.0000	0.0001	0.0200	<p>Defines the Constant C for IEEE characteristics. This setting is active and visible when the "Delay type" parameter is set to "IDMT" and the "Delay characteristic" parameter is set to "Param".</p>

Figure. 4.4.1 - 13. Inverse definite minimum time formulas for IEC and IEEE standards.

IEC	IEEE/ANSI																																																			
$t = \frac{kA}{\left(\frac{I_m}{I_{set}}\right)^B - 1}$	$t = k \left( \frac{A}{\left(\frac{I_m}{I_{set}}\right)^C - 1} + B \right)$																																																			
<p><i>t</i> = Operating delay (s)  <i>k</i> = Time dial setting  <i>I<sub>m</sub></i> = Measured maximum current  <i>I<sub>set</sub></i> = Pick-up setting  <i>A</i> = Operating characteristics constant  <i>B</i> = Operating characteristics constant</p>	<p><i>t</i> = Operating delay (s)  <i>k</i> = Time dial setting  <i>I<sub>m</sub></i> = Measured maximum current  <i>I<sub>set</sub></i> = Pick-up setting  <i>A</i> = Operating characteristics constant  <i>B</i> = Operating characteristics constant  <i>C</i> = Operating characteristics constant</p>																																																			
<p>Standard delays IEC constants</p> <table border="1"> <thead> <tr> <th>Type</th> <th>A</th> <th>B</th> </tr> </thead> <tbody> <tr> <td>Normally Inverse (NI)</td> <td>0,14</td> <td>0,02</td> </tr> <tr> <td>Extremely Inverse (EI)</td> <td>80</td> <td>2</td> </tr> <tr> <td>Very Inverse (VI)</td> <td>13,5</td> <td>1</td> </tr> <tr> <td>Long Time Inverse (LTI)</td> <td>120</td> <td>1</td> </tr> </tbody> </table>	Type	A	B	Normally Inverse (NI)	0,14	0,02	Extremely Inverse (EI)	80	2	Very Inverse (VI)	13,5	1	Long Time Inverse (LTI)	120	1	<p>Standard delays ANSI constants</p> <table border="1"> <thead> <tr> <th>Type</th> <th>A</th> <th>B</th> <th>C</th> </tr> </thead> <tbody> <tr> <td>Normally Inverse (NI)</td> <td>8,934</td> <td>0,1797</td> <td>2,094</td> </tr> <tr> <td>Very Inverse (VI)</td> <td>3,922</td> <td>0,0982</td> <td>2</td> </tr> <tr> <td>Extremely Inverse (EI)</td> <td>5,64</td> <td>0,02434</td> <td>2</td> </tr> <tr> <td>Long Time Inverse (LTI)</td> <td>5,614</td> <td>2,186</td> <td>1</td> </tr> </tbody> </table> <p>Standard delays IEEE constants</p> <table border="1"> <thead> <tr> <th>Type</th> <th>A</th> <th>B</th> <th>C</th> </tr> </thead> <tbody> <tr> <td>Moderately Inverse (MI)</td> <td>0,0515</td> <td>0,114</td> <td>0,02</td> </tr> <tr> <td>Very Inverse (VI)</td> <td>19,61</td> <td>0,491</td> <td>2</td> </tr> <tr> <td>Extremely Inverse (EI)</td> <td>28,2</td> <td>0,1217</td> <td>2</td> </tr> </tbody> </table>	Type	A	B	C	Normally Inverse (NI)	8,934	0,1797	2,094	Very Inverse (VI)	3,922	0,0982	2	Extremely Inverse (EI)	5,64	0,02434	2	Long Time Inverse (LTI)	5,614	2,186	1	Type	A	B	C	Moderately Inverse (MI)	0,0515	0,114	0,02	Very Inverse (VI)	19,61	0,491	2	Extremely Inverse (EI)	28,2	0,1217	2
Type	A	B																																																		
Normally Inverse (NI)	0,14	0,02																																																		
Extremely Inverse (EI)	80	2																																																		
Very Inverse (VI)	13,5	1																																																		
Long Time Inverse (LTI)	120	1																																																		
Type	A	B	C																																																	
Normally Inverse (NI)	8,934	0,1797	2,094																																																	
Very Inverse (VI)	3,922	0,0982	2																																																	
Extremely Inverse (EI)	5,64	0,02434	2																																																	
Long Time Inverse (LTI)	5,614	2,186	1																																																	
Type	A	B	C																																																	
Moderately Inverse (MI)	0,0515	0,114	0,02																																																	
Very Inverse (VI)	19,61	0,491	2																																																	
Extremely Inverse (EI)	28,2	0,1217	2																																																	

### Non-standard delay characteristics

In addition to the previously mentioned delay characteristics, some functions also have delay characteristics that deviate from the IEC or IEEE standards. These functions are the following:

- non-directional overcurrent stages
- non-directional earth fault stages
- directional overcurrent stages
- directional earth fault stages.

The setting parameters and their ranges are documented in the chapters of the respective function blocks.

Table. 4.4.1 - 27. Inverse definite minimum time formulas for nonstandard characteristics.

RI-type	RD-type
Used for getting the time grading with mechanical relays.	Mostly used in earth fault protection which grants selective tripping even in non-directional protection.
$t = \frac{k}{0.339 - 0.236 * \frac{I_{set}}{I_m}}$	$t = 5.8 - 1.35 * \ln \left( \frac{I_m}{k * I_{set}} \right)$
<p><i>t</i> = Operation delay (s)  <i>k</i> = Time dial setting  <i>I<sub>m</sub></i> = Measured maximum current  <i>I<sub>set</sub></i> = Pick-up setting</p>	<p><i>t</i> = Operation delay (s)  <i>k</i> = Time dial setting  <i>I<sub>m</sub></i> = Measured maximum current  <i>I<sub>set</sub></i> = Pick-up setting</p>



**NOTICE!**

When using RD-type and "k" has been set lower than 0.3 calculated operation time can be lower than 0 seconds with some measurement values. In these cases operation time will be instant.

When using the release delay option where the operating time counter is calculating the operating time during the release time, the function will not trip if the input signal is not activated again during the release time counting.

The behavior of the stages with different release time configurations are presented in the figures below.

Table. 4.4.1 - 28. Setting parameters for reset time characteristics.

Name	Range	Step	Default	Description
Delayed pick-up release	<ul style="list-style-type: none"> <li>• No</li> <li>• Yes</li> </ul>	-	Yes	Resetting characteristics selection (either time-delayed or instant) after the pick-up element is released. If set to "Yes", the START signal is reset after a set release time delay.
Release time delay	0.000...150.000s	0.005s	0.06s	Resetting time. The time allowed between pick-ups if the pick-up has not led into a trip operation. If the "Delayed pick-up release" setting is set to "Yes", the START signal is held on for the duration of the timer.
Op.Time calculation reset after release time	<ul style="list-style-type: none"> <li>• No</li> <li>• Yes</li> </ul>	-	Yes	Operating timer resetting characteristics selection. When set to "Yes", the operating time counter is reset after a set release time if the pick-up element is not activated during this time. When set to "No", the operating time counter is reset directly after the pick-up element is reset.
Continue time calculation during release time	<ul style="list-style-type: none"> <li>• No</li> <li>• Yes</li> </ul>	-	No	Time calculation characteristics selection. If set to "Yes", the operating time counter continues until a set release time even if the pick-up element is reset.

Figure. 4.4.1 - 14. No delayed pick-up release.

**Delayed pick-up release: Disabled**

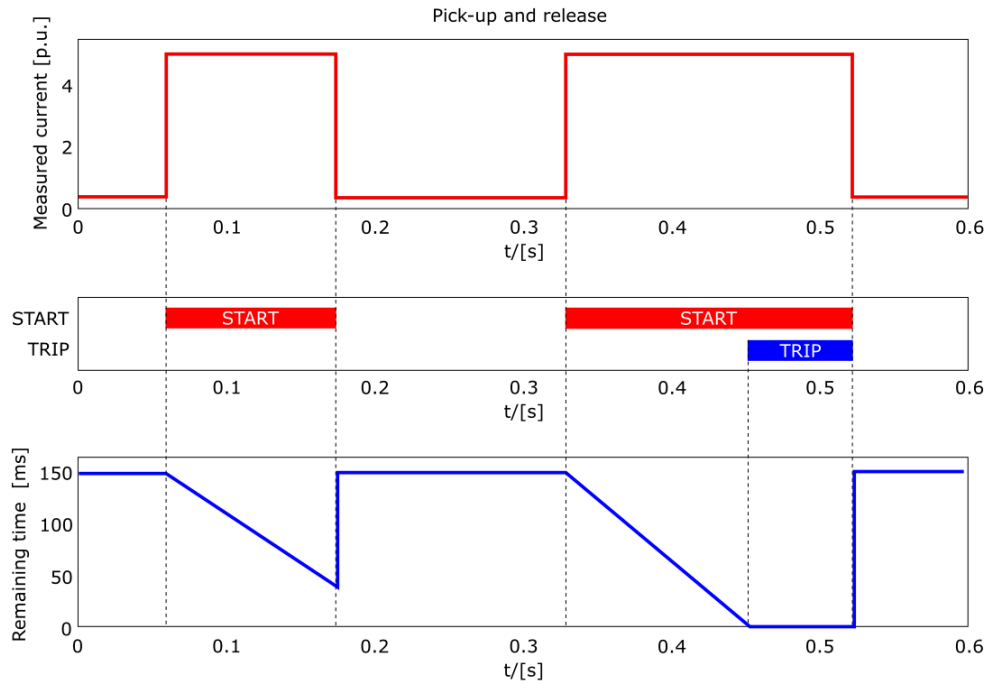

Figure. 4.4.1 - 15. Delayed pick-up release, delay counter is reset at signal drop-off.

**Delayed pick-up release: Enabled**  
**Op.time calc reset after release time: Disabled**  
**Continue time calculation during release time: Disabled**

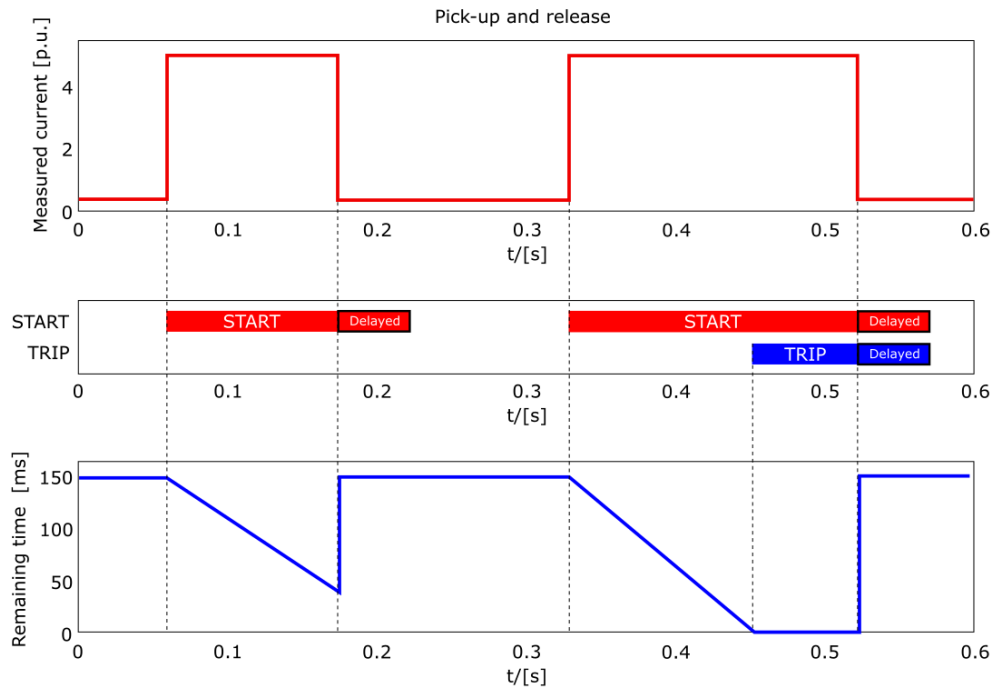

Figure. 4.4.1 - 16. Delayed pick-up release, delay counter value is held during the release time.

Delayed pick-up release: Enabled  
 Op.time calc reset after release time: Enabled  
 Continue time calculation during release time: Disabled

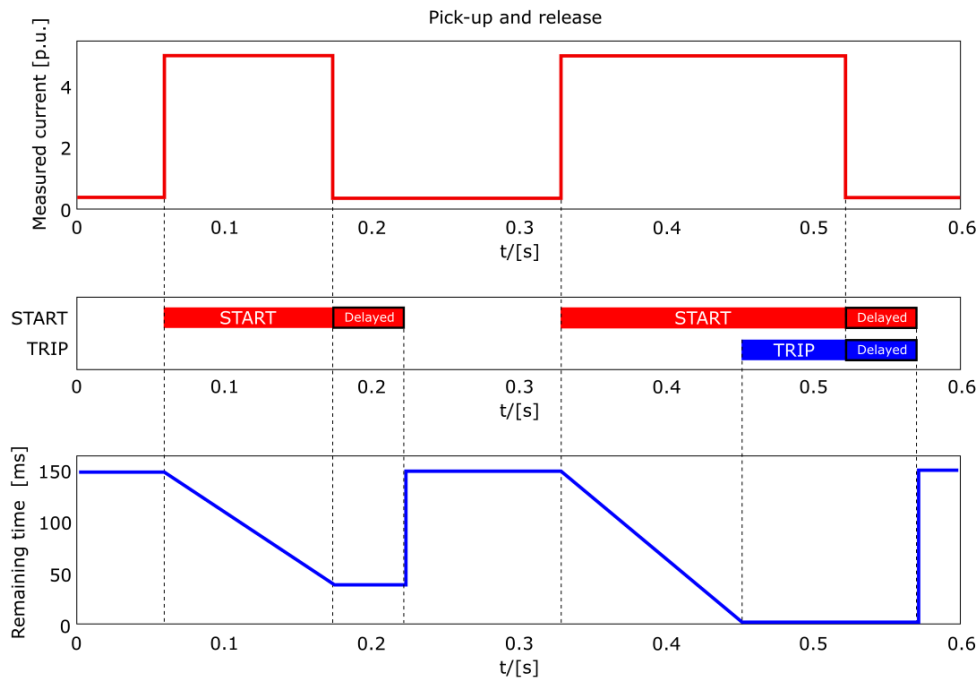
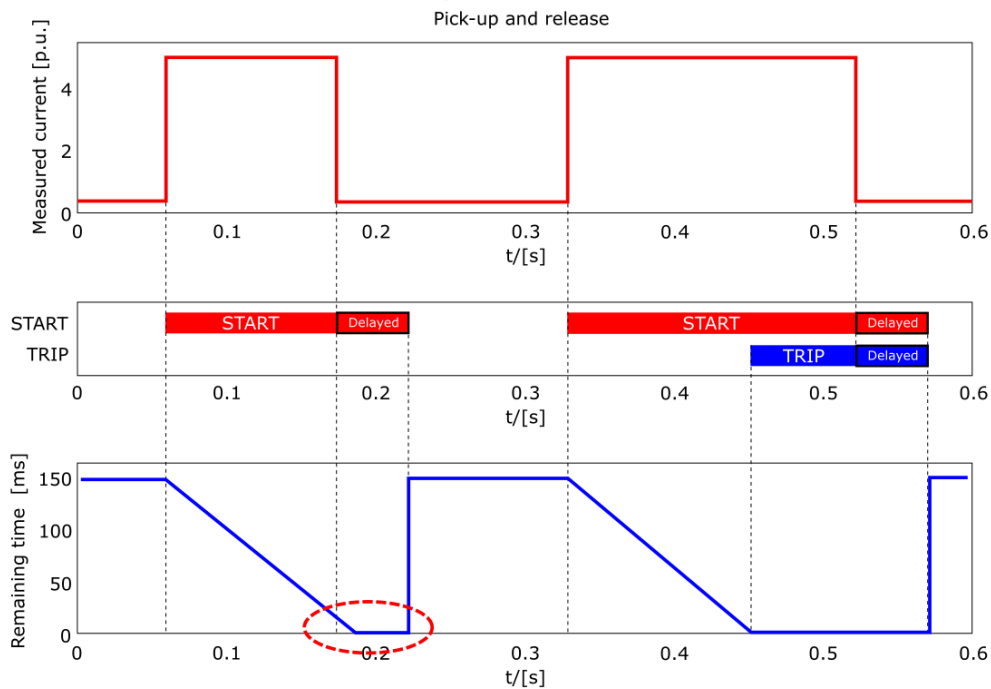

Figure. 4.4.1 - 17. Delayed pick-up release, delay counter value is decreasing during the release time.

Delayed pick-up release: Enabled  
 Op.time calc reset after release time: Enabled  
 Continue time calculation during release time: Enabled



## Stage forcing

It is possible to test the logic, event processing and the operation of the device's logic by controlling the state of the protection functions manually without injecting any current into the device with stage forcing. To enable *Stage forcing* set the *Enable stage forcing* to ENABLED in the *General* menu. After this it is possible to control the status of a protection function (Normal, Start, Trip, Blocked etc.) in the *Info* page of the function.



### NOTICE!

When *Stage forcing* is enabled protection functions will also change state through user input. Injected currents/voltages also affect the behavior of the device. Regardless, it is recommended to disable *Stage Forcing* after testing has ended.

## 4.4.2 Circuit breaker failure protection (CBFP; 50BF/52BF)

The circuit breaker failure protection function is used for monitoring the circuit breaker operation after it has received a TRIP signal. The function can also be used to retrip a failing breaker; if the retrip fails, an incoming feeder circuit breaker can be tripped by using the function's CBFP output. The retrip functionality can be disabled if the breaker does not have two trip coils.

The function can be triggered by the following:

- overcurrent (phase and residual)
- digital output monitor
- digital signal
- any combination of the above-mentioned triggers.

In the current-dependent mode the function constantly measures phase current magnitudes and the selected residual current. In the signal-dependent mode any of the device's binary signals (trips, starts, logical signals etc.) can be used to trigger the function. In the digital output-dependent mode the function monitors the status of the selected output relay control signal.

Figure. 4.4.2 - 18. Simplified function block diagram of the CBFP function.

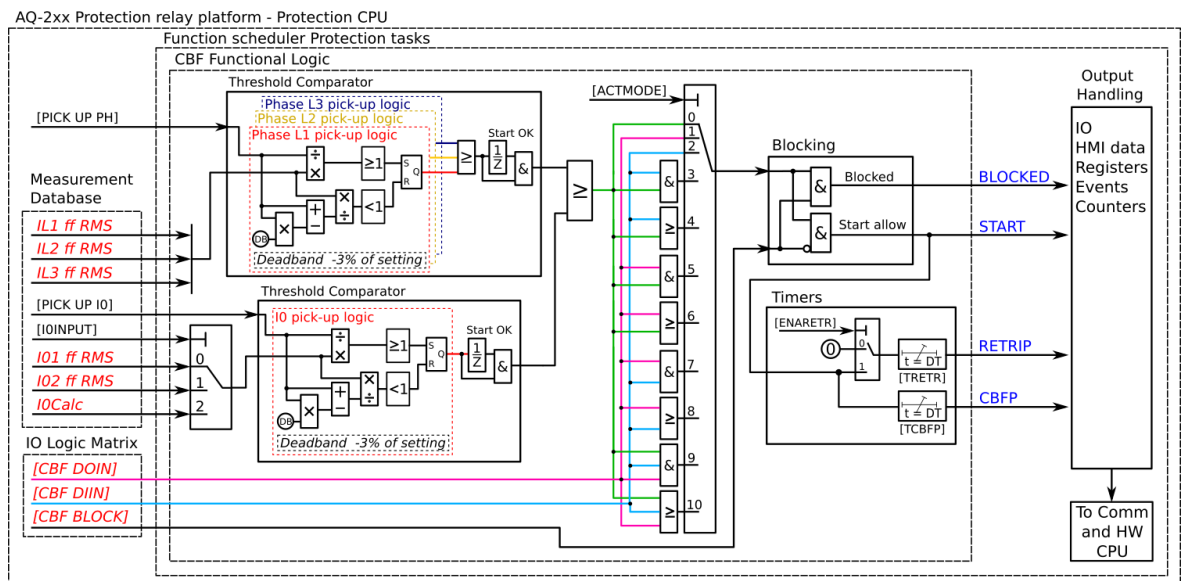

## General settings

The following general settings define the general behavior of the function. These settings are static i.e. it is not possible to change them by editing the setting group.

Table. 4.4.2 - 29. CBFP monitoring signal definitions.

Name	Description
Signal in monitor	Defines which TRIP events of the used protection functions trigger the CBFP countdown. For the CBFP function to monitor the signals selected here, the "Operation mode selection" parameter must be set to a mode that includes signals (e.g. "Signals only", "Signals or DO", "Current and signals and DO").
Trip monitor	Defines which output relay of the used protection functions trigger the CBFP countdown. For the CBFP function to monitor the output relays selected here, the "Operation mode selection" parameter must be set to a mode that includes digital outputs (e.g. "DO only", "Current and DO", "Current or signals or DO").

Table. 4.4.2 - 30. General settings of the function.

Name	Range	Default	Description
CBFP LN mode	<ul style="list-style-type: none"> <li>• On</li> <li>• Blocked</li> <li>• Test</li> <li>• Test/Blocked</li> <li>• Off</li> </ul>	On	Set mode of CBF block. This parameter is visible only when <i>Allow setting of individual LN mode</i> is enabled in <i>General</i> menu.
CBFP force status to	<ul style="list-style-type: none"> <li>• Normal</li> <li>• Start</li> <li>• ReTrip</li> <li>• CBFP</li> <li>• Blocked</li> </ul>	Normal	Force the status of the function. Visible only when <i>Enable stage forcing</i> parameter is enabled in <i>General</i> menu.

## Pick-up settings

The setting parameters  $I_{set}$  and  $IO_{set}$  control the pick-up and the activation of the current-dependent CBFP function. They define the minimum allowed measured current before action from the function. The function constantly calculates the ratio between the  $I_{set}$  or the  $IO_{set}$  and the measured magnitude ( $I_m$ ) for each of the three phases and the selected residual current input. The reset ratio of 97 % is built into the function and is always relative to the  $I_{set}$  value. The setting value is common for all measured phases. When the  $I_m$  exceeds the  $I_{set}$  value (in single, dual or all phases) it triggers the pick-up operation of the function.

Setting group selection controls the operating characteristics of the function, i.e. the user or user-defined logic can change function parameters while the function is running.

Table. 4.4.2 - 31. Operating mode and input signals selection.

Name	Range	Step	Default	Description
I0Input	<ul style="list-style-type: none"> <li>Not in use</li> <li>I01</li> <li>I02</li> <li>I0Calc</li> </ul>	-	Not in use	Selects the residual current monitoring source, which can be either from the two separate residual measurements (I01 and I02) or from the phase current's calculated residual current.
Actmode	<ul style="list-style-type: none"> <li>Current only</li> <li>DO only</li> <li>Signals only</li> <li>Current and DO</li> <li>Current or DO</li> <li>Current and signals</li> <li>Current or signals</li> <li>Signals and DO</li> <li>Signals or DO</li> <li>Current or DO or signals</li> <li>Current and DO and Signals</li> </ul>	-	Current only	Selects the operating mode. The mode can be dependent on current measurement, binary signal status, output relay status ("DO"), or a combination of the three.

Table. 4.4.2 - 32. Pick-up settings.

Name	Range	Step	Default	Description
I <sub>set</sub>	0.01...40.00×I <sub>n</sub>	0.01×I <sub>n</sub>	0.20×I <sub>n</sub>	The pick-up threshold for the phase current measurement. This setting limit defines the upper limit for the phase current pick-up element.
I0 <sub>set</sub>	0.005...40.000×I <sub>n</sub>	0.001×I <sub>n</sub>	1.200×I <sub>n</sub>	The pick-up threshold for the residual current measurement. This setting limit defines the upper limit for the phase current pick-up element.

### Read-only parameters

The function's *Info* page displays useful, real-time information on the state of the protection function. It is accessed either through the device's HMI display, or through the setting tool software when it is connected to the device and its Live Edit mode is active.

Table. 4.4.2 - 33. Information displayed by the function.

Name	Range	Description
CBFP LN behaviour	<ul style="list-style-type: none"> <li>• On</li> <li>• Blocked</li> <li>• Test</li> <li>• Test/Blocked</li> <li>• Off</li> </ul>	<p>Displays the mode of CBF block.</p> <p>This parameter is visible only when <i>Allow setting of individual LN mode</i> is enabled in <i>General</i> menu.</p>
CBFP condition	<ul style="list-style-type: none"> <li>• Normal</li> <li>• Start</li> <li>• ReTrip</li> <li>• CBFP On</li> <li>• Blocked</li> </ul>	<p>Displays status of the protection function.</p>

### Function blocking

The block signal is checked in the beginning of each program cycle. The blocking signal is received from the blocking matrix in the function's dedicated input. If the blocking signal is not activated when the pick-up element activates, a START signal is generated and the function proceeds to the time characteristics calculation.

If the blocking signal is active when the pick-up element activates, a BLOCKED signal is generated and the function does not process the situation further. If the START function has been activated before the blocking signal, it resets and processes the release time characteristics similarly to when the pick-up signal is reset.

The variables the user can set are binary signals from the system. The blocking signal needs to reach the device minimum of 5 ms before the set operating delay has passed in order for the blocking to activate in time.

### Operating time characteristics

The operating timers' behavior during a function can be set depending on the application. The same pick-up signal starts both timers. When retrip is used the time grading should be set as follows: the sum of specific times (i.e. the retrip time, the expected operating time, and the pick-up conditions' release time) is shorter the set CBFP time. This way, when retripping another breaker coil clears the fault, any unnecessary function triggers are avoided.

The following table presents the setting parameters for the function's operating time characteristics.

Table. 4.4.2 - 34. Setting parameters for operating time characteristics.

Name	Range	Step	Default	Description
Retrip	<ul style="list-style-type: none"> <li>• No</li> <li>• Yes</li> </ul>	-	Yes	Retrip enabled or disabled. When the retrip is disabled, the output will not be visible and the TRetr setting parameter will not be available.
Retrip time delay	0.000...1800.000s	0.005s	0.100s	Retrip start the timer. This setting defines how long the starting condition has to last before a RETRIP signal is activated.

Name	Range	Step	Default	Description
CBFP	0.000...1800.000s	0.005s	0.200s	CBFP starts the timer. This setting defines how long the starting condition has to last before the CBFP signal is activated.

The following figures present some typical cases of the CBFP function.

## Trip, Retrip and CBFP in the device configuration

Figure. 4.4.2 - 19. Wiring diagram when Trip, Retrip and CBFP are configured to the device.

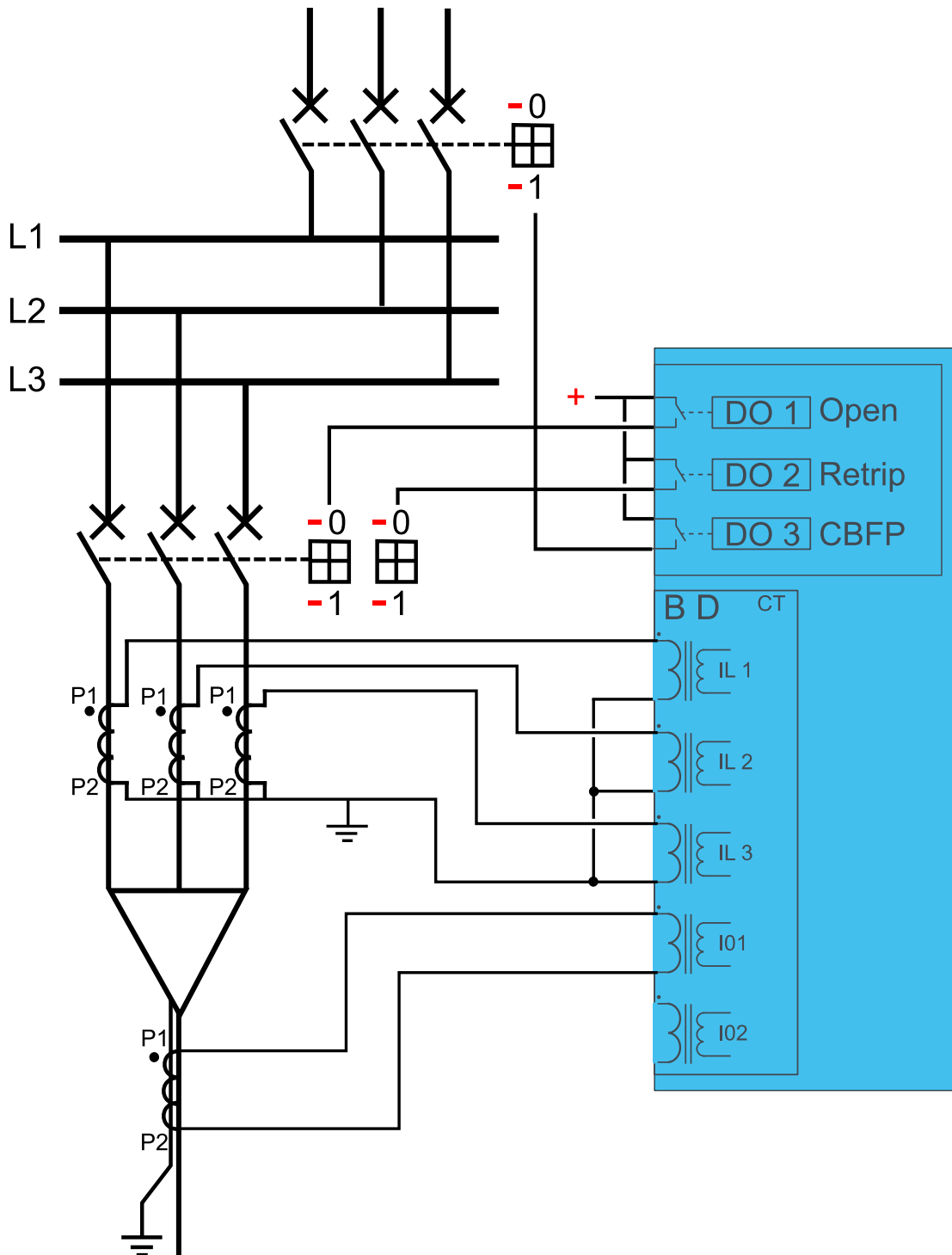

The retrip functionality can be used in applications whose circuit breaker has a retrip or a redundant trip coil available. The TRIP signal is normally wired to the breaker's trip coil from the device's trip output. The retrip is wired from its own device output contact in parallel with the circuit breaker's redundant trip coil. The CBFP signal is normally wired from its device output contact to the incoming feeder circuit breaker. Below are a few operational cases regarding the various applications.

Figure. 4.4.2 - 20. Retrip and CBFP when "Current" is the selected criterion.

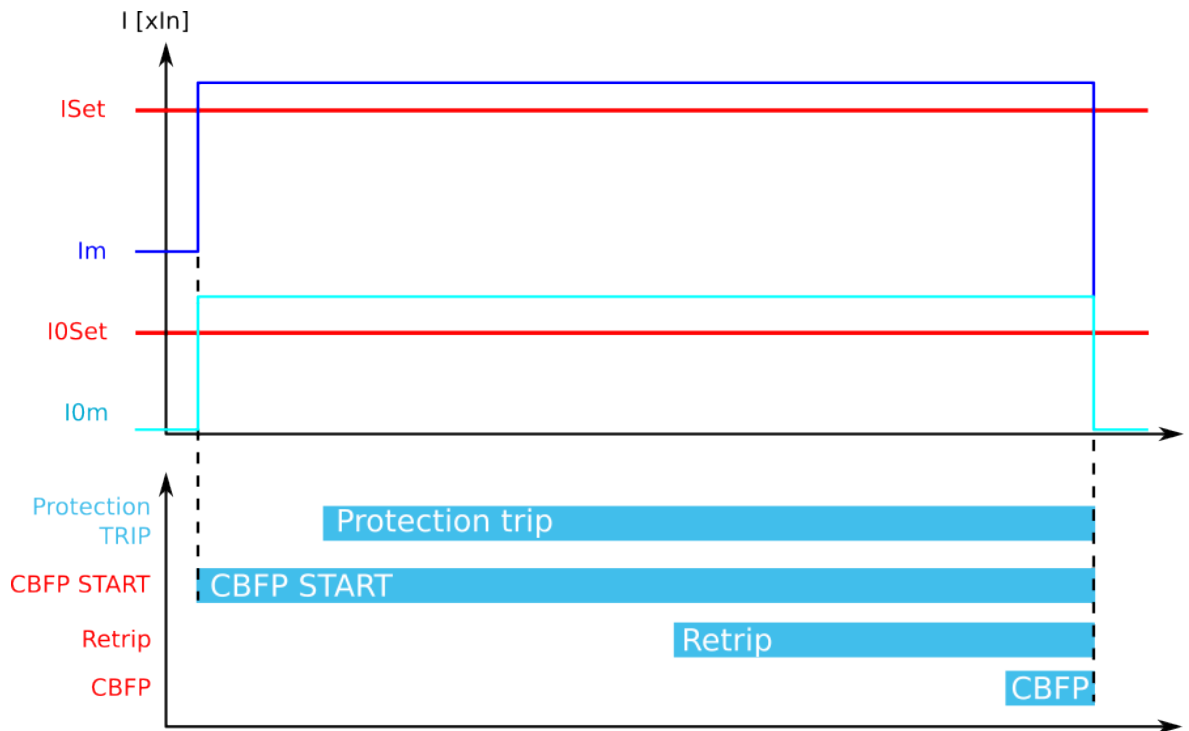

When the current threshold setting of  $I_{set}$  and/or  $I_{Oset}$  is exceeded, the current-based protection is activated and the counters for RETRIP and CBFP start calculating the set operating time. The tripping of the primary protection stage is not monitored in this configuration. Therefore, if the current is not reduced below the setting limit, a RETRIP signal is sent to the redundant trip coil. If the current is not reduced within the set time limit, the function also sends a CBFP signal to the incoming feeder breaker. If the primary protection function clears the fault, both counters (RETRIP and CBFP) are reset as soon as the measured current is below the threshold settings.

Figure. 4.4.2 - 21. Retrip and CBFP when "Current and DO" is the selected criterion.

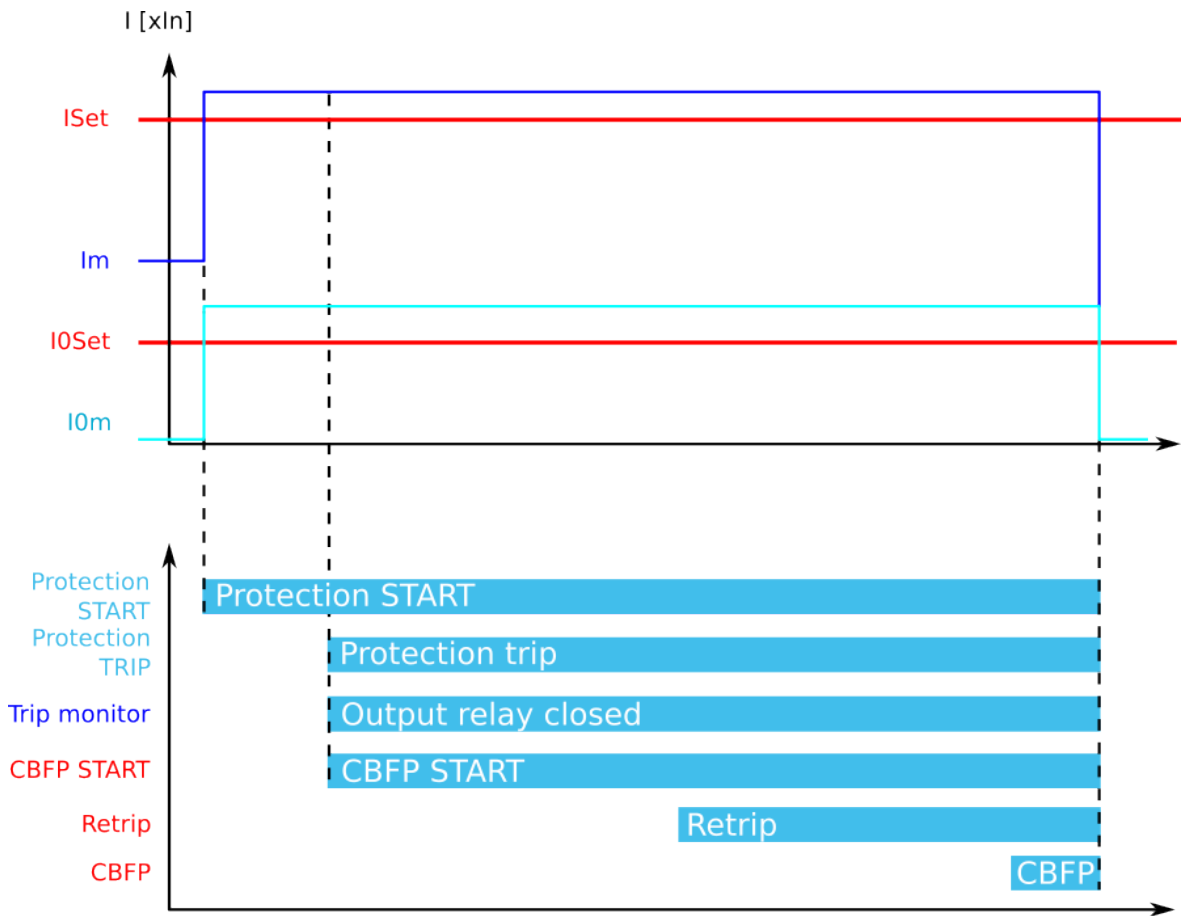

When the current threshold setting of  $I_{set}$  and/or  $I_{Oset}$  is exceeded, the current-based protection is activated. At the same time, the counters for RETRIP and CBFP are halted until the monitored output contact is controlled (that is, until the primary protection operates). When the tripping signal reaches the primary protection stage, the RETRIP and CBFP counters start calculating the set operating time. The tripping of the primary protection stage is constantly monitored in this configuration. If the current is not reduced below the setting limit or the primary stage tripping signal is not reset, a RETRIP signal is sent to the redundant trip coil. If the retripping fails and the current is not reduced below the setting limit or the primary stage tripping signal is not reset, the function also sends a CBFP signal to the incoming feeder circuit breaker. If the primary protection function clears the fault, both counters (RETRIP and CBFP) are reset as soon as the measured current is below the threshold settings or the tripping signal is reset. This configuration allows the CBFP to be controlled with current-based functions alone, and other function trips can be excluded from the CBFP functionality.

Figure. 4.4.2 - 22. Retrip and CBFP when "Current or DO" is the selected criterion.

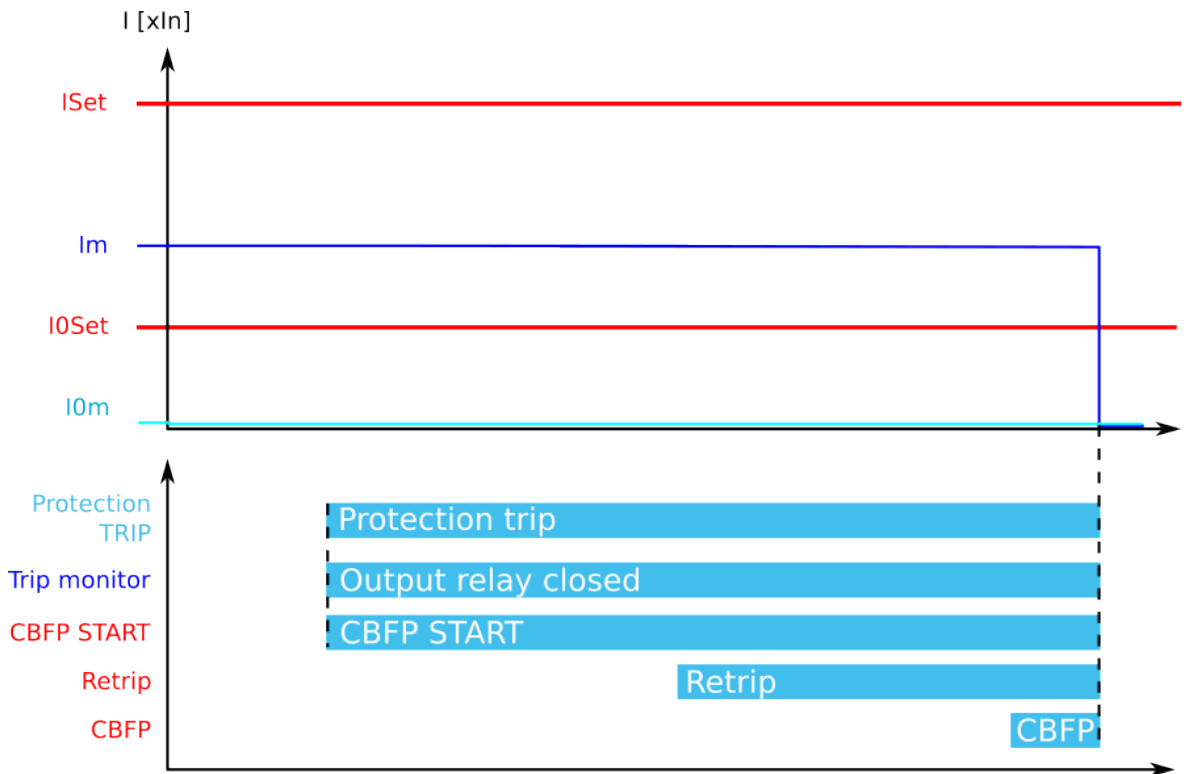

When the current threshold setting of  $I_{set}$  and/or  $I_{0set}$  is exceeded, or the TRIP signal reaches the primary protection stage, the function starts counting down towards the RETRIP and CBFP signals. The tripping of the primary protection stage is constantly monitored in this configuration regardless of the current's status. The pick-up of the CBFP is active unless the current is reduced below the setting limit and the primary stage tripping signal is reset. If either of these conditions is met (i.e. the current is above the limit or the signal is active) for the duration of the set RETRIP time delay, a RETRIP signal is sent to the redundant trip coil. If either of the conditions is active for the duration of the set CBFP time delay, a CBFP signal is sent to the incoming feeder circuit breaker. If the primary protection function clears the fault, both counters (RETRIP and CBFP) are reset as soon as the measured current is below the threshold settings and the tripping signal is reset. This configuration allows the CBFP to be controlled with current-based functions alone, with added security from current monitoring. Other function trips can also be included in the CBFP functionality.

### Trip and CBFP in the device configuration

Figure. 4.4.2 - 23. Wiring diagram when Trip and CBFP are configured to the device.

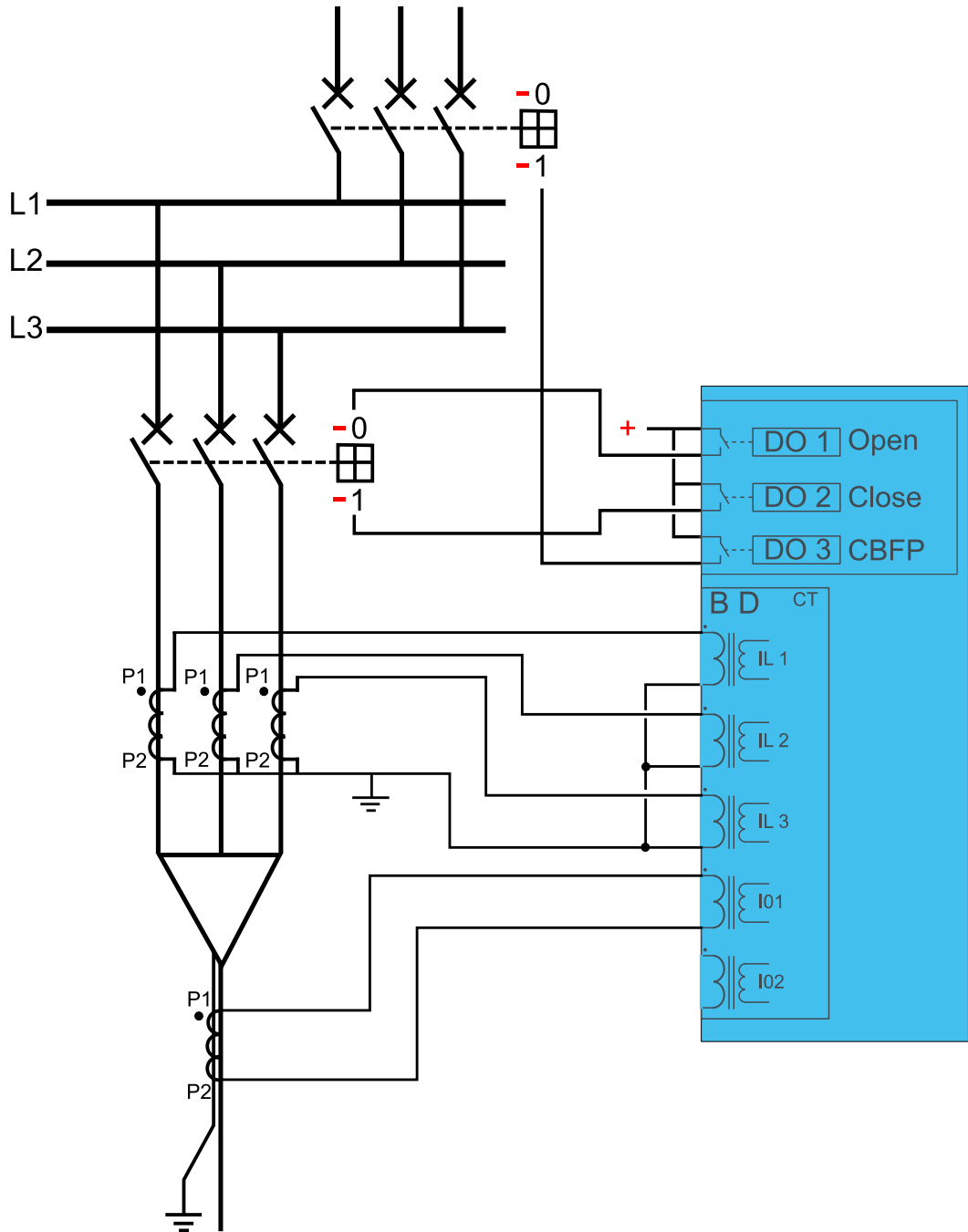

Probably the most common application is when the device's trip output controls the circuit breaker trip coil, while one dedicated CBFP contact controls the CBFP function. Below are a few operational cases regarding the various applications and settings of the CBFP function.

Figure. 4.4.2 - 24. CBFP when "Current" is the selected criterion.

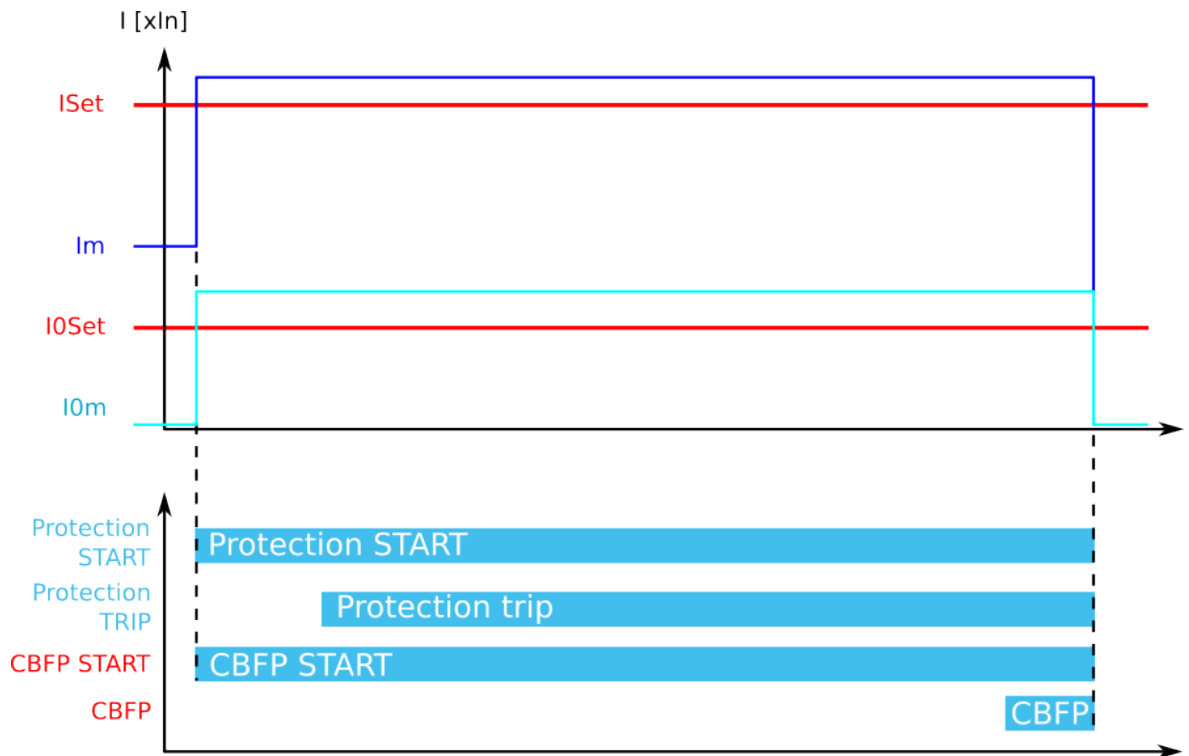

When the current threshold setting of  $I_{Set}$  and/or  $I_{OSet}$  is exceeded, the current-based protection is activated and the counter for CBFP starts calculating the set operating time. The tripping of the primary protection stage is not monitored in this configuration. Therefore, if the current is not reduced below the setting limit, a CBFP signal is sent to the incoming feeder circuit breaker. If the primary protection function clears the fault, the counter for CBFP resets as soon as the measured current is below the threshold settings.

Figure. 4.4.2 - 25. CBFP when "Current and DO" is the selected criterion.

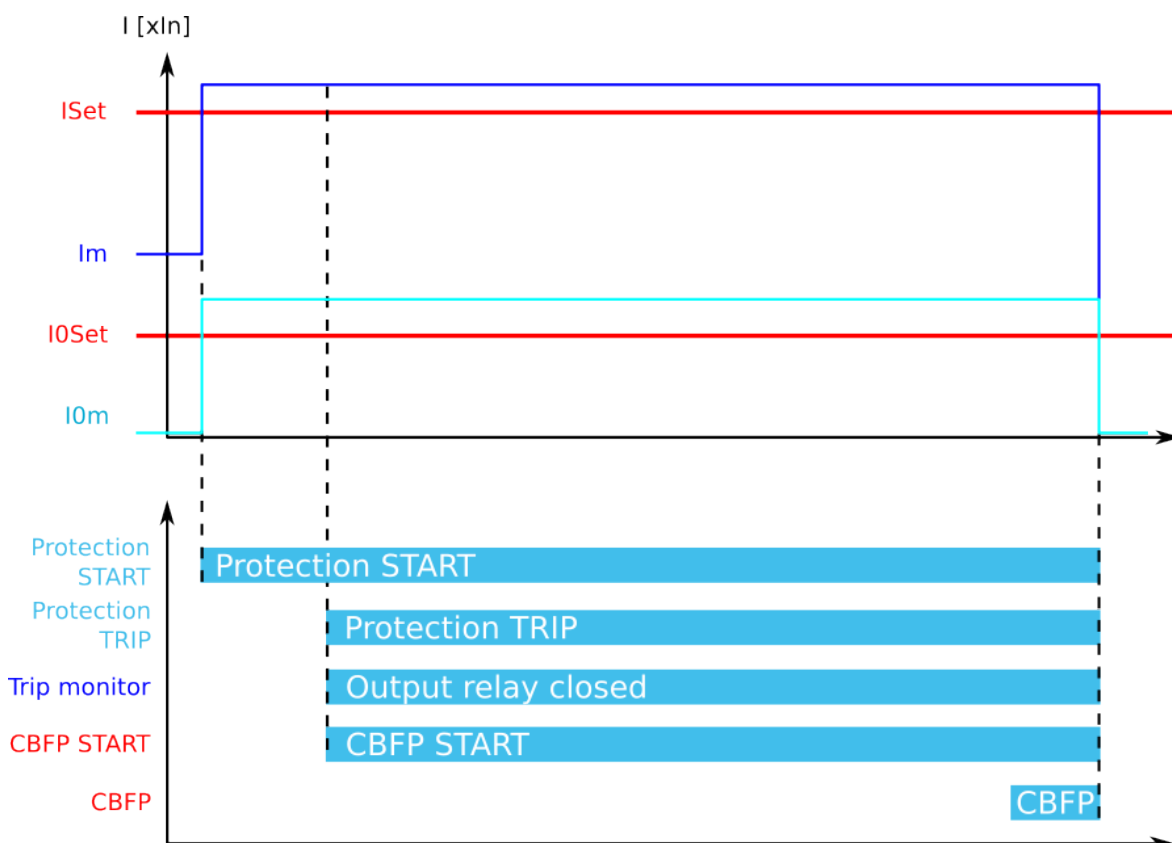

When the current threshold setting of  $I_{set}$  and/or  $IO_{set}$  is exceeded, the current-based protection is activated. At the same time, the counter for CBFP is halted until the monitored output contact is controlled (that is, until the primary protection operates). When the tripping signal reaches the primary protection stage, the CBFP counter starts calculating the set operating time. The tripping of the primary protection stage is constantly monitored in this configuration. If the current is not reduced below the setting limit or the primary stage tripping signal is not reset, a CBFP signal is sent to the incoming feeder circuit breaker. The time delay counter for CBFP is reset as soon as the measured current is below the threshold settings or the tripping signal is reset. This configuration allows the CBFP to be controlled by current-based functions alone, and other function trips can be excluded from the CBFP functionality.

Figure. 4.4.2 - 26. CBFP when "Current or DO" is the selected criterion.

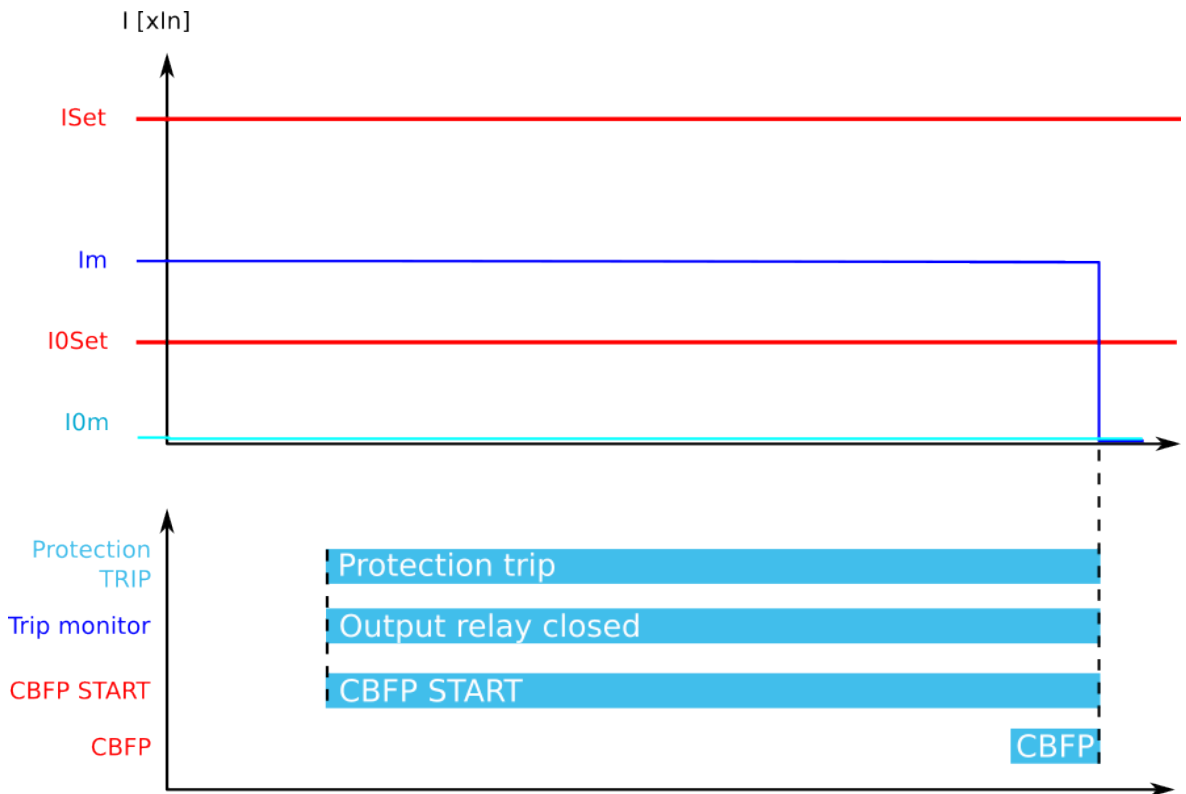

When the current threshold setting of  $I_{set}$  and/or  $I_{Oset}$  is exceeded, or the TRIP signal reaches the primary protection stage, the function starts counting down towards the CBFP signal. The tripping of the primary protection stage is constantly monitored in this configuration regardless of the current's status. The pick-up of the CBFP is active unless the current is reduced below the setting limit and the primary stage tripping signal is reset. If either of these conditions is met (i.e. the current is above the limit or the signal is active) for the duration of the set CBFP time delay, a CBFP signal is sent to the incoming feeder circuit breaker. The time delay counter for CBFP is reset as soon as the measured current is below the threshold settings and the tripping signal is reset. This configuration allows the CBFP to be controlled by current-based functions alone, with added security from current monitoring. Other function trips can also be included to the CBFP functionality.

## Device configuration as a dedicated CBFP unit

Figure. 4.4.2 - 27. Wiring diagram when the device is configured as a dedicated CBFP unit.

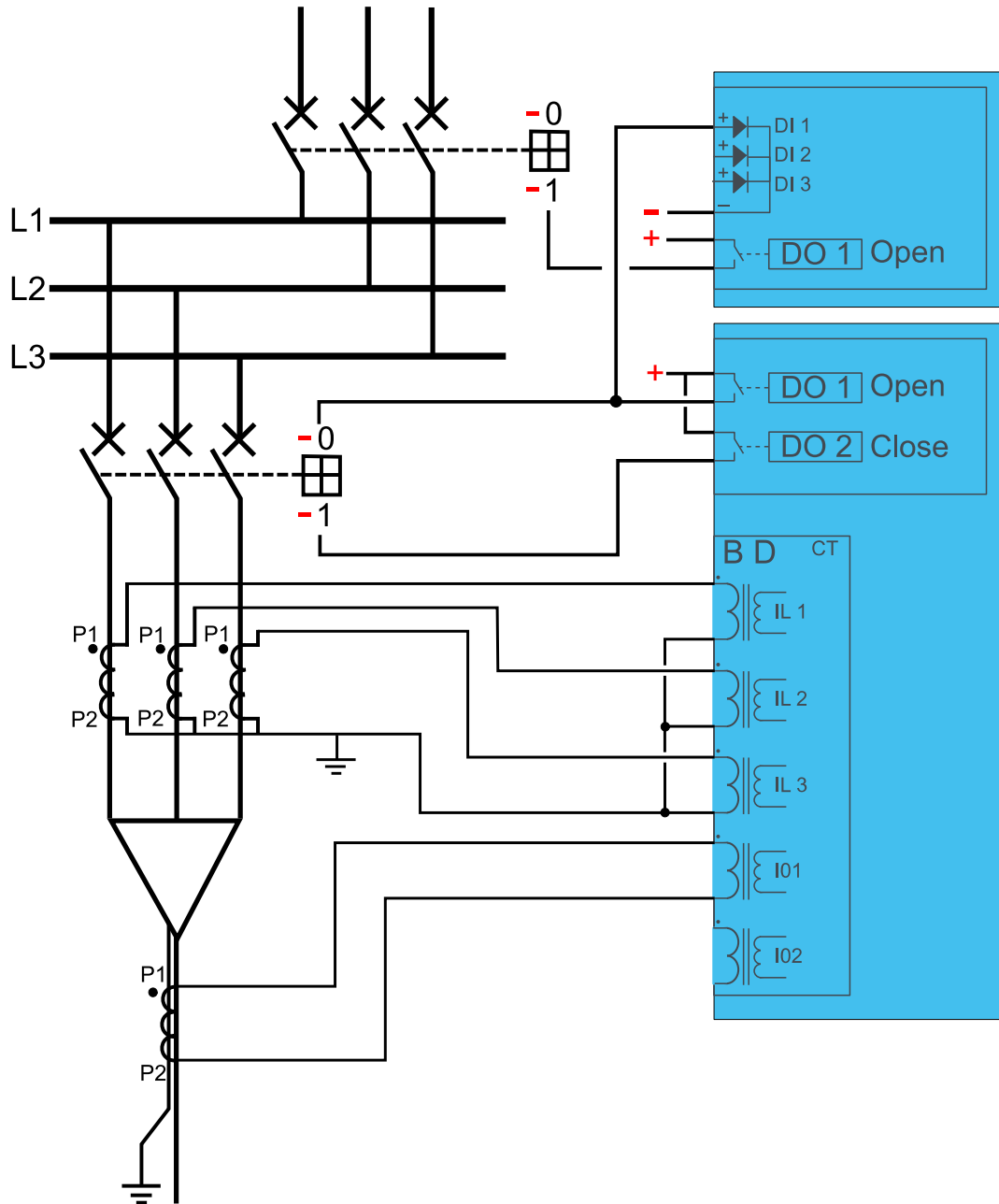

Some applications require a dedicated circuit breaker protection unit. When the CBFP function is configured to operate with a digital input signal, it can be used in these applications. When a device is used for this purpose, the tripping signal is wired to the device's digital input and the device's own TRIP signal is used only for the CBFP purpose. In this application's incoming feeder the RETRIP and CBFP signals are also available with different sets of requirements. The RETRIP signal can be used for tripping the section's feeder breaker and the CBFP signal for tripping the incoming feeder. The following example does not use retripping and the CBFP signal is used as the incoming feeder trip from the outgoing breaker trip signal. The TRIP signal can also be transported between different devices by using GOOSE messages.

Figure. 4.4.2 - 28. Dedicated CBFP operation from digital input signal.

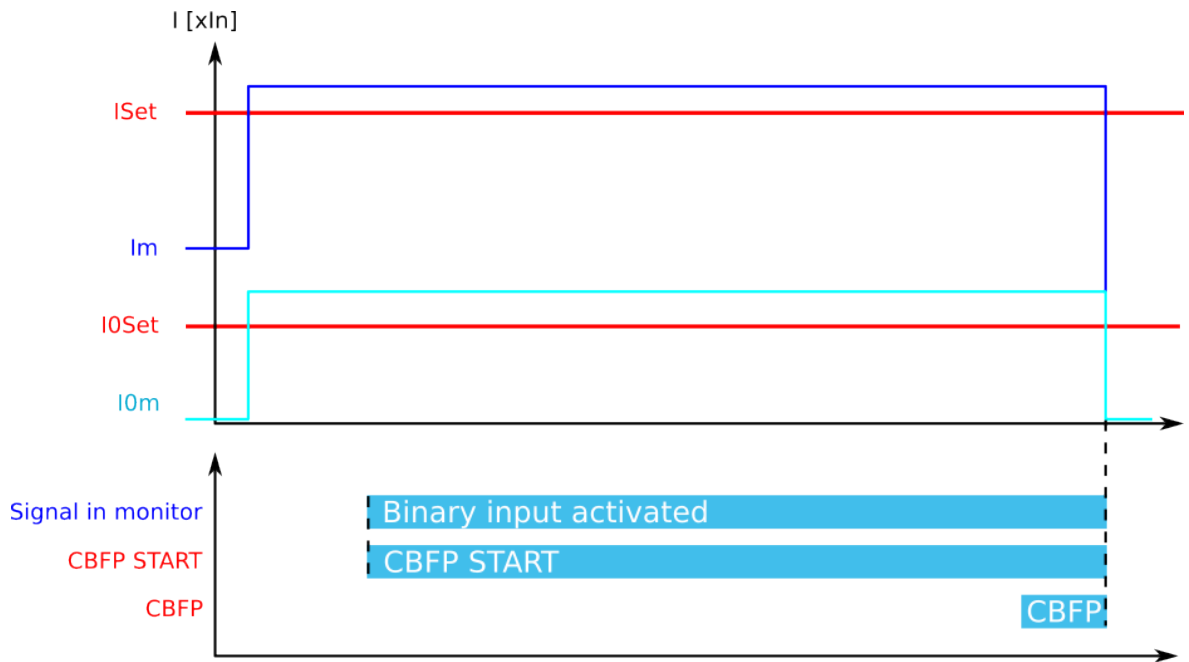

In this mode the CBFP operates only from a digital input signal. Both current and output relay monitoring can be used. The counter for the CBFP signal begins when the digital input is activated. If the counter is active until the CBFP counter is used, the device issues a CBFP command to the incoming feeder circuit breaker. In this application the device tripping signals from all outgoing feeders can be connected to one, dedicated CBFP device which operates either on current-based protection or on all possible faults' CBFP protection.

### Events and registers

The circuit breaker failure protection function (abbreviated "CBF" in event block names) generates events and registers from the status changes in the events listed below. The user can select which event messages are stored in the main event buffer: ON, OFF, or both. The events triggered by the function are recorded with a time stamp.

The function's outputs can be used for direct I/O controlling and user logic programming. The function also provides a resettable cumulative counters for RETRIP, CBFP, CBFP START and BLOCKED events.

Table. 4.4.2 - 35. Event messages.

Event block name	Event names
CBF1	Start ON/OFF
CBF1	Retrip ON/OFF
CBF1	CBFP ON/OFF
CBF1	Block ON/OFF
CBF1	DO monitor ON/OFF
CBF1	Signal ON/OFF
CBF1	Phase current ON/OFF
CBF1	Res current ON/OFF

The function registers its operation into the last twelve (12) time-stamped registers. The register of the function records the ON event process data for ACTIVATED, BLOCKED, etc. The table below presents the structure of the function's register content.

Table. 4.4.2 - 36. Register content.

Register	Description
Date and time	dd.mm.yyyy hh:mm:ss.mss
Event	Event name
Max phase current	Highest phase current
Residual current	I01, I02 channel or calculated residual current
Time to RETR	Time remaining to retrip activation
Time to CBFP	Time remaining to CBFP activation
Setting group in use	Setting group 1...8 active

### 4.4.3 Overvoltage protection (U>; 59)

The overvoltage function is used for instant and time-delayed overvoltage protection. Devices with a voltage protection module has four (4) available stages of the function (U>, U>>, U>>>, U>>>>). The function constantly measures phase voltage magnitudes or line-to-line magnitudes.

Figure. 4.4.3 - 29. Simplified function block diagram of the U> function.

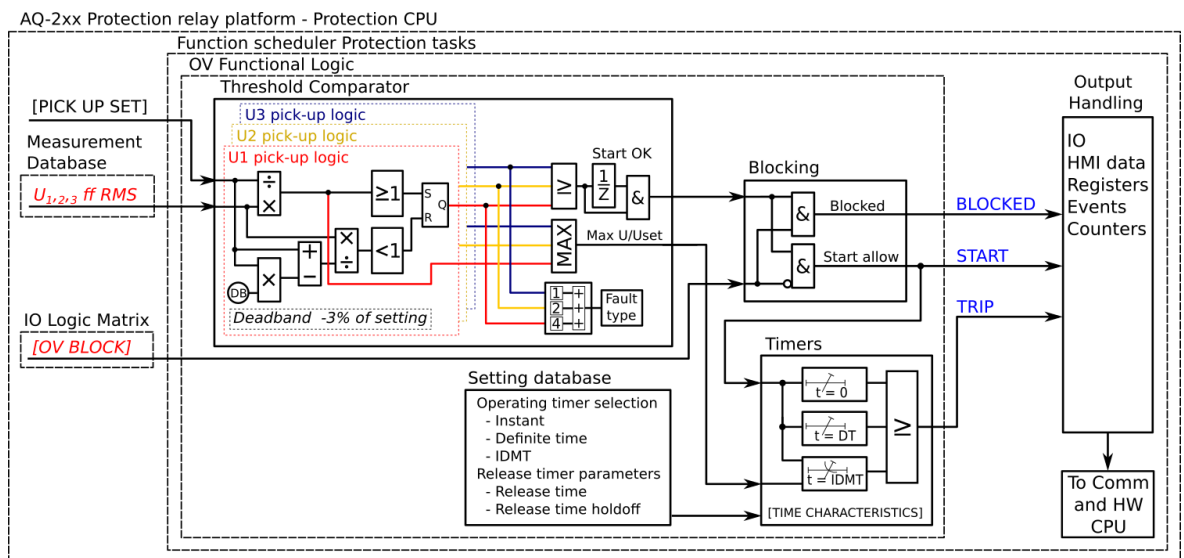

#### Measured input

The function block uses fundamental frequency component of line-to-line or line-to-neutral (as the user selects). If the protection is based on line-to-line voltage, overvoltage protection is not affected by earth faults in isolated or compensated networks.

Table. 4.4.3 - 37. Measurement input of the U> function.

Signal	Description
U <sub>L12</sub> RMS	Fundamental frequency component of U <sub>L12</sub> /V voltage measurement
U <sub>L23</sub> RMS	Fundamental frequency component of U <sub>L23</sub> /V voltage measurement
U <sub>L31</sub> RMS	Fundamental frequency component of U <sub>L31</sub> /V voltage measurement
U <sub>L1</sub> RMS	Fundamental frequency component of U <sub>L1</sub> /V voltage measurement
U <sub>L2</sub> RMS	Fundamental frequency component of U <sub>L2</sub> /V voltage measurement
U <sub>L3</sub> RMS	Fundamental frequency component of U <sub>L3</sub> /V voltage measurement

Table. 4.4.3 - 38. Measured magnitude selection settings.

Name	Range	Default	Description
Measured magnitude	<ul style="list-style-type: none"> <li>• P-P voltages</li> <li>• P-E voltages</li> <li>• U3 input (2LL-U3SS)</li> <li>• U4 input (SS)</li> </ul>	P-P voltages	Selection of phase-to-phase or phase-to-earth voltages. Additionally, the U3 or U4 input can be assigned as the voltage channel to be supervised.

Figure. 4.4.3 - 30. Selectable measurement magnitudes with 3LN+U4 VT connection.

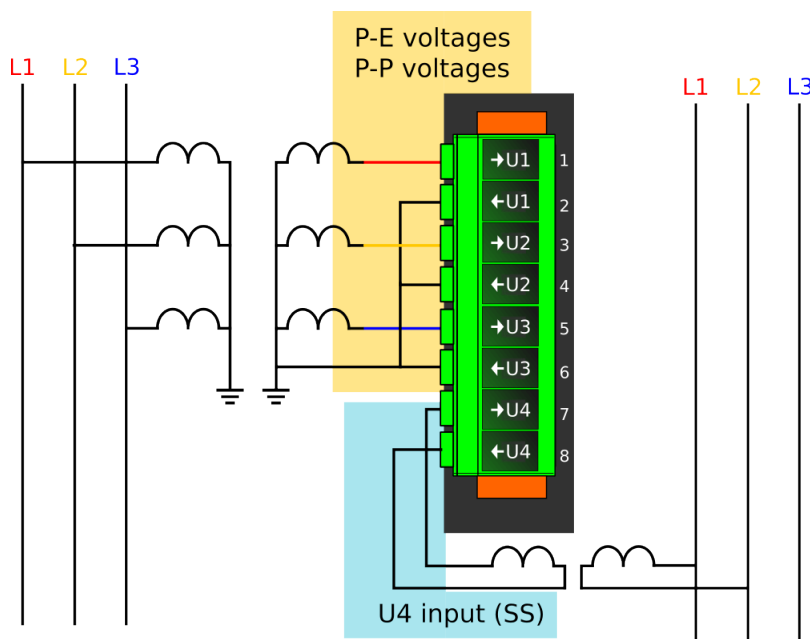

Figure. 4.4.3 - 31. Selectable measurement magnitudes with 3LL+U4 VT connection (P-E voltages not available without residual voltage).

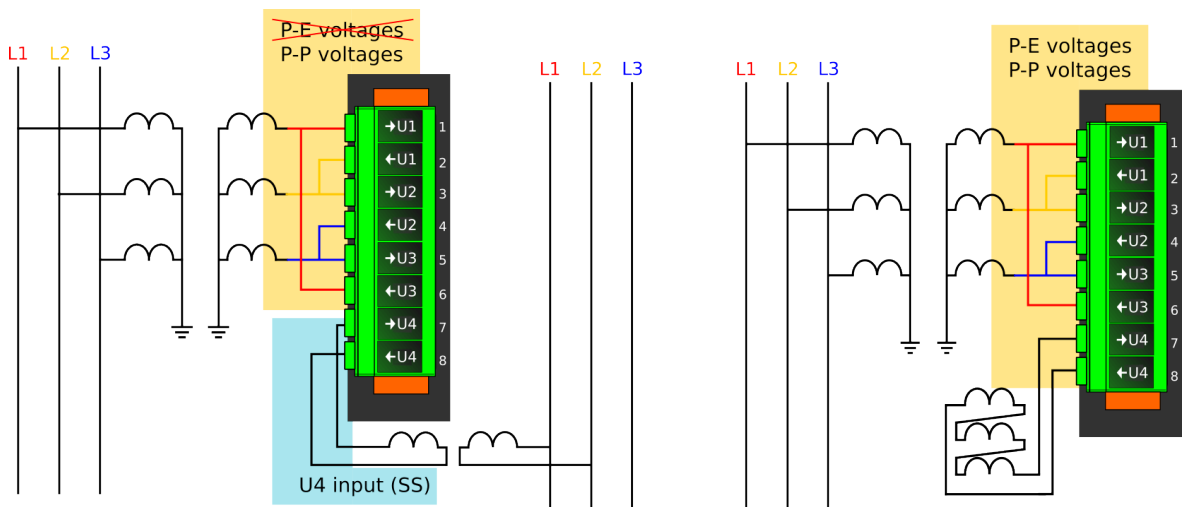
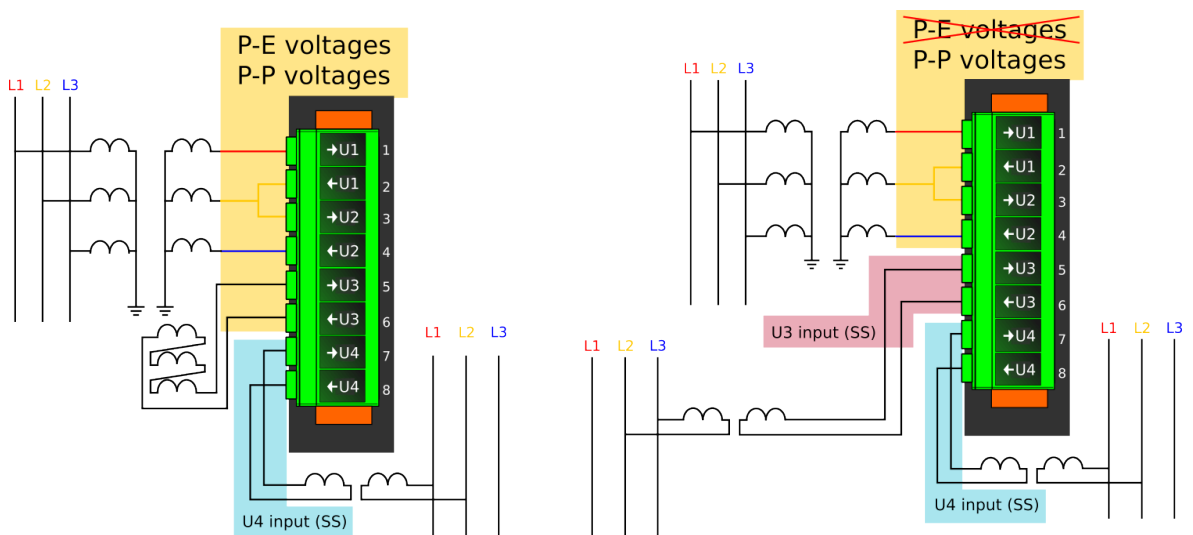

Figure. 4.4.3 - 32. Selectable measurement magnitudes with 2LL+U3+U4 VT connection (P-E voltages not available without residual voltage).



*P-P Voltages* and *P-E Voltages* selections follow phase-to-neutral or phase-to-phase voltages in the first three voltage channels (or two first voltage channels in the 2LL+U3+U4 mode). *U4 input* selection follows the voltage in Channel 4. *U3 input* selection only follows the voltage in Channel 3 if the 2LL+U3+U4 mode is in use.

## General settings

The following general settings define the general behavior of the function. These settings are static i.e. it is not possible to change them by editing the setting group.

Table. 4.4.3 - 39. General settings of the function.

Name	Range	Default	Description
U> LN mode	<ul style="list-style-type: none"> <li>On</li> <li>Blocked</li> <li>Test</li> <li>Test/Blocked</li> <li>Off</li> </ul>	On	Set mode of OV block. This parameter is visible only when <i>Allow setting of individual LN mode</i> is enabled in <i>General</i> menu.
U> force status to	<ul style="list-style-type: none"> <li>Normal</li> <li>Start</li> <li>Trip</li> <li>Blocked</li> </ul>	Normal	Force the status of the function. Visible only when <i>Enable stage forcing</i> parameter is enabled in <i>General</i> menu.

### Pick-up settings

The  $U_{set}$  setting parameter controls the pick-up of the U> function. This defines the maximum allowed measured voltage before action from the function. The function constantly calculates the ratio between the  $U_{set}$  and the measured magnitude ( $U_m$ ) for each of the three voltages. The reset ratio of 97 % is built into the function and is always relative to the  $U_{set}$  value. The setting value is common for all measured amplitudes, and when the  $U_m$  exceeds the  $U_{set}$  value (in single, dual or all voltages) it triggers the pick-up operation of the function.

Setting group selection controls the operating characteristics of the function, i.e. the user or user-defined logic can change function parameters while the function is running.

Table. 4.4.3 - 40. Pick-up settings.

Name	Range	Step	Default	Description
Operation mode	<ul style="list-style-type: none"> <li>1 voltage</li> <li>2 voltages</li> <li>3 voltages</li> </ul>	-	1 voltage	Pick-up criteria selection
$U_{set}$	0.01...250.00% $U_n$	0.01% $U_n$	105% $U_n$	Pick-up setting

### Read-only parameters

The function's *Info* page displays useful, real-time information on the state of the protection function. It is accessed either through the device's HMI display, or through the setting tool software when it is connected to the device and its Live Edit mode is active.

Table. 4.4.3 - 41. Information displayed by the function.

Name	Range	Step	Description
U> LN behaviour	<ul style="list-style-type: none"> <li>On</li> <li>Blocked</li> <li>Test</li> <li>Test/Blocked</li> <li>Off</li> </ul>	-	Displays the mode of OV block. This parameter is visible only when <i>Allow setting of individual LN mode</i> is enabled in <i>General</i> menu.

Name	Range	Step	Description
U< pick-up setting	0.0...1 000 000.0V	0.1V	The primary voltage required for tripping. The displayed pick-up voltage level depends on the pick-up setting and the voltage transformer settings.
Expected operating time	0.000...1800.000s	0.005s	Displays the expected operating time when a fault occurs. When IDMT mode is used, the expected operating time depends on the measured voltage value. If the measured voltage changes during a fault, the expected operating time changes accordingly.
Time remaining to trip	-1800.000...1800.000s	0.005s	When the function has detected a fault and counts down time towards a trip, this displays how much time is left before tripping occurs.
$U_{A(B)}$ meas/ $U_{set}$ at the moment	0.00...1250.00 $U_m/U_{set}$	0.01 $U_m/U_{set}$	The ratio between $U_A$ or $U_{AB}$ voltage and the pick-up value.
$U_{B(c)}$ meas/ $U_{set}$ at the moment	0.00...1250.00 $U_m/U_{set}$	0.01 $U_m/U_{set}$	The ratio between $U_B$ or $U_{BC}$ voltage and the pick-up value.
$U_{C(A)}$ meas/ $U_{set}$ at the moment	0.00...1250.00 $U_m/U_{set}$	0.01 $U_m/U_{set}$	The ratio between $U_C$ or $U_{CA}$ voltage and the pick-up value.
$U_{meas}/U_{set}$ at the moment	0.00...1250.00 $U_m/U_{set}$	0.01 $U_m/U_{set}$	The ratio between the measured voltage and the pick-up value.

## Function blocking

The blocking signal is evaluated at the start of each program cycle. The blocking signals are connected to the function's dedicated input, which can be configured in the *IO* → *Blocking Input Control* tab of the function.

- When the pick-up element activates and the blocking signal is not active, a START signal is generated, and the function starts or continues with the trip time countdown.
- When the pick-up element activates and the blocking signal is active, a BLOCKED signal is generated, and the function does not process the event further.
- When a START signal is already active and the blocking input signal becomes active, the START signal is reset and BLOCKED signal is generated. The release time characteristics are then processed in the same way as when the pick-up signal is reset.

The blocking signal needs to reach the device minimum of 5 ms before the set operating delay has passed in order for the blocking to activate in time.

## Operating time characteristics for trip and reset

The operating timers' behavior during a function can be set for TRIP signal and also for the release of the function in case the pick-up element is reset before the trip time has been reached. There are three basic operating modes available for the function:

- Instant operation: gives the TRIP signal with no additional time delay simultaneously with the START signal.

- Definite time operation (DT): gives the TRIP signal after a user-defined time delay regardless of the measured voltage as long as the voltage is above the  $U_{set}$  value and thus the pick-up element is active (independent time characteristics).
- Inverse definite minimum time (IDMT): gives the TRIP signal after a time which is in relation to the set pick-up voltage  $U_{set}$  and the measured voltage  $U_m$  (dependent time characteristics).

The IDMT function follows this formula:

$$t = \frac{k}{\left(\frac{U_m}{U_s}\right)^a - 1}$$

Where:

- $t$  = operating time
- $k$  = time dial setting
- $U_m$  = measured voltage
- $U_s$  = pick-up setting
- $a$  = IDMT Multiplier setting

The following table presents the setting parameters for the function's time characteristics.

Table. 4.4.3 - 42. Setting parameters for operating time characteristics.

Name	Range	Step	Default	Description
Delay type	<ul style="list-style-type: none"> <li>• DT</li> <li>• IDMT</li> </ul>	-	DT	Selection of the delay type time counter. The selection possibilities are dependent (IDMT, Inverse Definite Minimum Time) and independent (DT, Definite Time) characteristics.
Definite operating time delay	0.000...800.000s	0.005s	0.040s	Definite time operating delay. The setting is active and visible when DT is the selected delay type. When set to 0.000 s, the stage operates as instant stage without added delay. When the parameter is set to 0.005...1800 s, the stage operates as independent delayed.
Time dial setting k	0.01...60.00s	0.01s	0.05s	This setting is active and visible when IDMT is the selected delay type. Time dial/multiplier setting for IDMT characteristics.
IDMT Multiplier	0.01...25.00s	0.01s	1.00s	This setting is active and visible when IDMT is the selected delay type. IDMT time multiplier in the $U_m/U_{set}$ power.

Table. 4.4.3 - 43. Setting parameters for reset time characteristics.

Name	Range	Step	Default	Description
Release time delay	0.000...150.000s	0.005s	0.06s	Resetting time. The time allowed between pick-ups if the pick-up has not led to a trip operation. During this time the START signal is held on for the timers if the delayed pick-up release is active.
Delayed pick-up release	<ul style="list-style-type: none"> <li>• No</li> <li>• Yes</li> </ul>	-	Yes	Resetting characteristics selection either as time-delayed or as instant after the pick-up element is released. If activated the START signal is reset after the set release time delay.

Name	Range	Step	Default	Description
Time calc reset after release time	<ul style="list-style-type: none"> <li>No</li> <li>Yes</li> </ul>	-	Yes	Operating timer resetting characteristics selection. When active, the operating time counter is reset after a set release time if the pick-up element is not activated during this time. When disabled, the operating time counter is reset directly after the pick-up element is reset.
Continue time calculation during release time	<ul style="list-style-type: none"> <li>No</li> <li>Yes</li> </ul>	-	No	Time calculation characteristics selection. If activated, the operating time counter is continuing until a set release time has passed even if the pick-up element is reset.

## Events and registers

The overvoltage function (abbreviated "OV" in event block names) generates events and registers from the status changes in the events listed below. The user can select which event messages are stored in the main event buffer: ON, OFF, or both. The events triggered by the function are recorded with a time stamp.

The function's outputs can be used for direct I/O controlling and user logic programming. The function also provides a resettable cumulative counter for the START, TRIP and BLOCKED events.

The function offers four (4) independent stages; the events are segregated for each stage operation.

Table. 4.4.3 - 44. Event messages.

Event block name	Event names
OV1...OV4	Start ON/OFF
OV1...OV4	Trip ON/OFF
OV1...OV4	Block ON/OFF

The function registers its operation into the last twelve (12) time-stamped registers; this information is available for all provided instances separately. The register of the function records the ON event process data for START, TRIP or BLOCKED. The table below presents the structure of the function's register content.

Table. 4.4.3 - 45. Register content.

Register	Description
Date and time	dd.mm.yyyy hh:mm:ss.mss
Event	Event name
Fault type	L1-G...L1-L2-L3
Pre-trigger voltage	Start/Trip -20ms voltage
Pre-fault voltage	Start -200ms voltage
Trip time remaining	0 ms...1800s

Register	Description
Used SG	Setting group 1...8 active

### 4.4.4 Undervoltage protection (U<; 27)

The undervoltage function is used for instant and time-delayed undervoltage protection. Devices with a voltage protection module has four (4) available stages of the function (U>, U>>, U>>>, U>>>>). The function constantly measures phase voltage magnitudes or line-to-line voltage magnitudes. Undervoltage protection has two blocking stages: internal blocking (based on voltage measurement and low voltage), or external blocking (e.g. during voltage transformer fuse failure).

Figure. 4.4.4 - 33. Simplified function block diagram of the U< function.

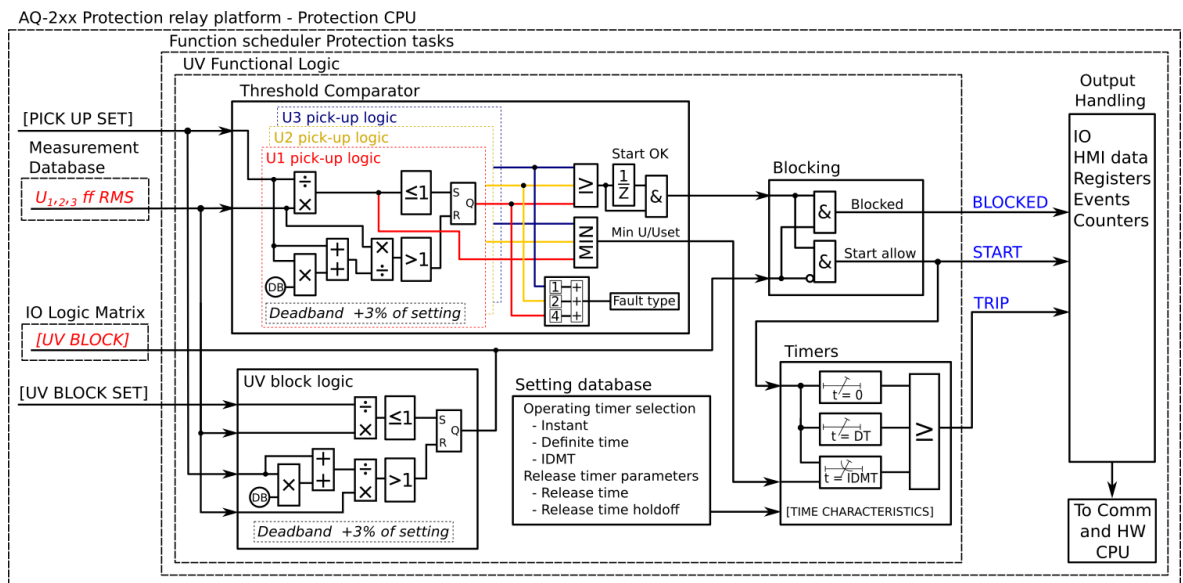

### Measured input

The function block uses fundamental frequency component of line-to-line or line-to-neutral (as the user selects). If the protection is based on line-to-line voltage, undervoltage protection is not affected by earth faults in isolated or compensated networks.

Table. 4.4.4 - 46. Measurement input of the U> function.

Signal	Description
U <sub>L12</sub> RMS	Fundamental frequency component of U <sub>L12</sub> /V voltage measurement
U <sub>L23</sub> RMS	Fundamental frequency component of U <sub>L23</sub> /V voltage measurement
U <sub>L31</sub> RMS	Fundamental frequency component of U <sub>L31</sub> /V voltage measurement
U <sub>L1</sub> RMS	Fundamental frequency component of U <sub>L1</sub> /V voltage measurement
U <sub>L2</sub> RMS	Fundamental frequency component of U <sub>L2</sub> /V voltage measurement
U <sub>L3</sub> RMS	Fundamental frequency component of U <sub>L3</sub> /V voltage measurement

Table. 4.4.4 - 47. Measured magnitude selection settings.

Name	Range	Default	Description
Measured magnitude	<ul style="list-style-type: none"> <li>• P-P voltages</li> <li>• P-E voltages</li> <li>• U3 input (2LL-U3SS)</li> <li>• U4 input (SS)</li> </ul>	P-P voltages	Selection of P-P or P-E voltages. Additionally, the U3 or U4 input can be assigned as the voltage channel to be supervised.

Figure. 4.4.4 - 34. Selectable measurement magnitudes with 3LN+U4 VT connection.

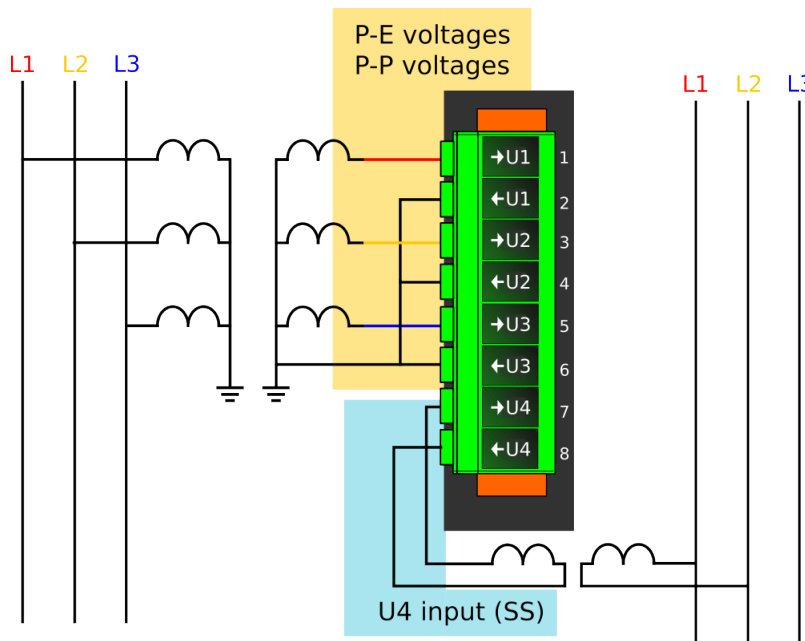

Figure. 4.4.4 - 35. Selectable measurement magnitudes with 3LL+U4 VT connection (P-E voltages not available without residual voltage).

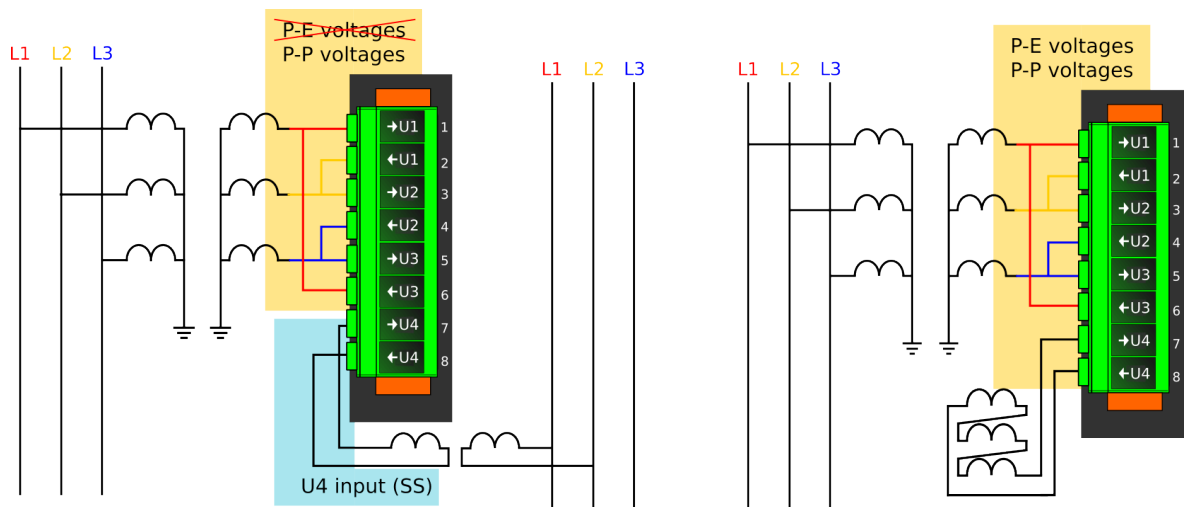
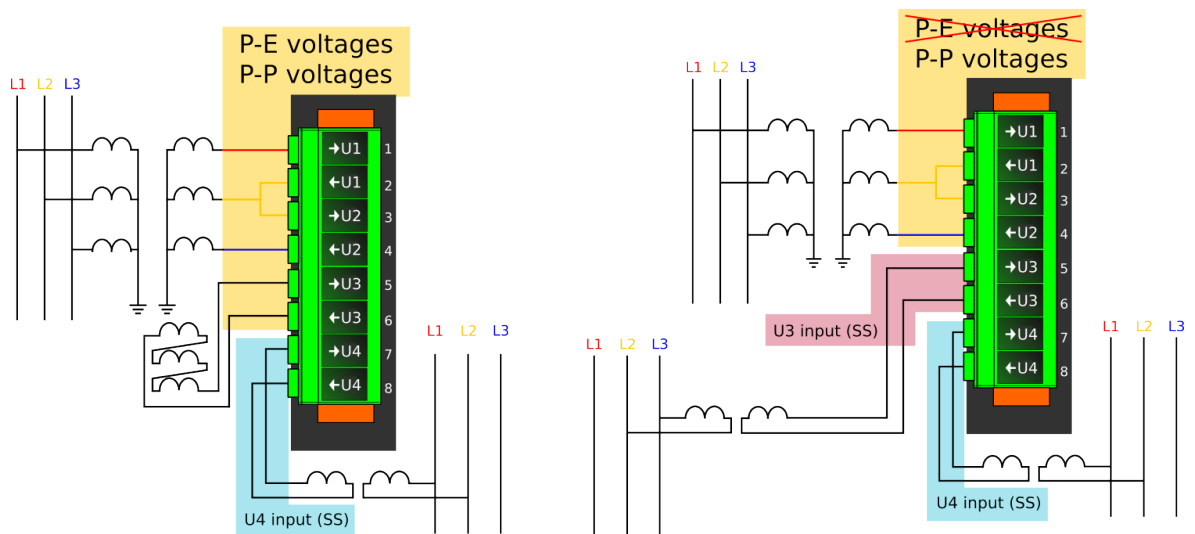

Figure. 4.4.4 - 36. Selectable measurement magnitudes with 2LL+U4 VT connection (P-E voltages not available without residual voltage).



*P-P Voltages* and *P-E Voltages* selections follow phase-to-neutral or phase-to-phase voltages in the first three voltage channels (or two first voltage channels in the 2LL+U3+U4 mode). *U4 input* selection follows the voltage in Channel 4. *U3Input* selection only follows the voltage in Channel 3 if the 2LL+U3+U4 mode is in use.

### General settings

The following general settings define the general behavior of the function. These settings are static i.e. it is not possible to change them by editing the setting group.

Table. 4.4.4 - 48. General settings of the function.

Name	Range	Default	Description
U< LN mode	<ul style="list-style-type: none"> <li>On</li> <li>Blocked</li> <li>Test</li> <li>Test/Blocked</li> <li>Off</li> </ul>	On	Set mode of UV block. This parameter is visible only when <i>Allow setting of individual LN mode</i> is enabled in <i>General</i> menu.
U< force status to	<ul style="list-style-type: none"> <li>Normal</li> <li>Start</li> <li>Trip</li> <li>Blocked</li> </ul>	Normal	Force the status of the function. Visible only when <i>Enable stage forcing</i> parameter is enabled in <i>General</i> menu.

### Pick-up settings

The  $U_{set}$  setting parameter controls the pick-up of the U< function. This defines the minimum allowed measured voltage before action from the function. The function constantly calculates the ratio between the  $U_{set}$  and the measured magnitude ( $U_m$ ) for each of the three voltages. The reset ratio of 103 % is built into the function and is always relative to the  $U_{set}$  value. The setting value is common for all measured amplitudes, and when the  $U_m$  exceeds the  $U_{set}$  value (in single, dual or all voltages) it triggers the pick-up operation of the function.

Setting group selection controls the operating characteristics of the function, i.e. the user or user-defined logic can change function parameters while the function is running.

Table. 4.4.4 - 49. Pick-up settings.

Name	Range	Step	Default	Description
$U_{set}$	0.00...120.00% $U_n$	0.01% $U_n$	60% $U_n$	Pick-up setting
U Block setting	0.00...100.00% $U_n$	0.01% $U_n$	10% $U_n$	Block setting. If set to zero, blocking is not in use. The operation is explained in the next chapter.

### Using *Block setting* to prevent nuisance trips

It is recommended to use the *Block setting* parameter to prevent the device from tripping in a situation where the network is de-energized. When the measured voltage drops below the set value, the device does not give a tripping signal. If the measured voltage has dropped below the *Block setting* parameter, the blocking continues until all of the line voltages have increased above the  $U_{<}$  pick-up setting. Please see the image below for a visualization of this function. If the block level is set to zero (0), blocking is not in use.

Figure. 4.4.4 - 37. Example of the block setting operation.

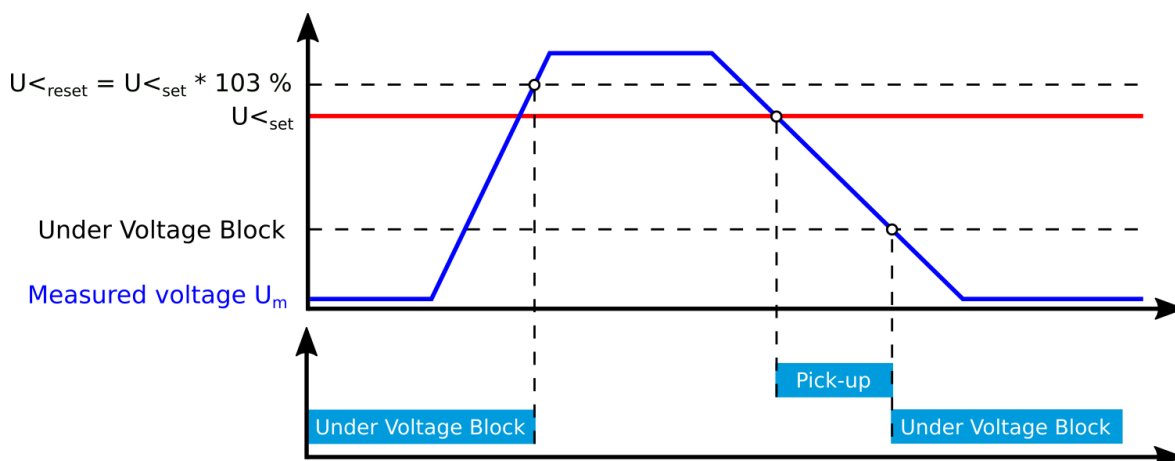

### Read-only parameters

The function's *Info* page displays useful, real-time information on the state of the protection function. It is accessed either through the device's HMI display, or through the setting tool software when it is connected to the device and its Live Edit mode is active.

Table. 4.4.4 - 50. Information displayed by the function.

Name	Range	Step	Description
$U_{<}$ LN behaviour	<ul style="list-style-type: none"> <li>On</li> <li>Blocked</li> <li>Test</li> <li>Test/Blocked</li> <li>Off</li> </ul>	-	Displays the mode of UV block. This parameter is visible only when <i>Allow setting of individual LN mode</i> is enabled in <i>General</i> menu.
$U_{<}$ pick-up setting	0.0...1 000 000.0V	0.1V	The primary voltage required for tripping. The displayed pick-up voltage level depends on the pick-up setting and the voltage transformer settings.

Name	Range	Step	Description
U< block setting	0.0...1 000 000.0V	0.1V	The primary voltage level required for trip blocking. If the measured voltage is below this value, the network is considered de-energized and the function will not trip. To deactivate the blocking the measured voltage must exceed the pick-up setting value.
Expected operating time	0.000...1800.000s	0.005s	Displays the expected operating time when a fault occurs. When IDMT mode is used, the expected operating time depends on the measured voltage value. If the measured voltage changes during a fault, the expected operating time changes accordingly.
Time remaining to trip	-1800.000...1800.000s	0.005s	When the function has detected a fault and counts down time towards a trip, this displays how much time is left before tripping occurs.
$U_{A(B)}$ meas/ $U_{set}$ at the moment	0.00...1250.00 $U_m/U_{set}$	0.01 $U_m/U_{set}$	The ratio between $U_A$ or $U_{AB}$ voltage and the pick-up value.
$U_{B(c)}$ meas/ $U_{set}$ at the moment	0.00...1250.00 $U_m/U_{set}$	0.01 $U_m/U_{set}$	The ratio between $U_B$ or $U_{BC}$ voltage and the pick-up value.
$U_{C(A)}$ meas/ $U_{set}$ at the moment	0.00...1250.00 $U_m/U_{set}$	0.01 $U_m/U_{set}$	The ratio between $U_C$ or $U_{CA}$ voltage and the pick-up value.
$U_{meas}/U_{set}$ at the moment	0.00...1250.00 $U_m/U_{set}$	0.01 $U_m/U_{set}$	The ratio between the lowest measured phase or line voltage and the pick-up value.

## Function blocking

The blocking signal is evaluated at the start of each program cycle. The blocking signals are connected to the function's dedicated input, which can be configured in the *IO* → *Blocking Input Control* tab of the function.

- When the pick-up element activates and the blocking signal is not active, a START signal is generated, and the function starts or continues with the trip time countdown.
- When the pick-up element activates and the blocking signal is active, a BLOCKED signal is generated, and the function does not process the event further.
- When a START signal is already active and the blocking input signal becomes active, the START signal is reset and BLOCKED signal is generated. The release time characteristics are then processed in the same way as when the pick-up signal is reset.

The blocking signal needs to reach the device minimum of 5 ms before the set operating delay has passed in order for the blocking to activate in time.

## Operating time characteristics for trip and reset

The operating timers' behavior during a function can be set for TRIP signal and also for the release of the function in case the pick-up element is reset before the trip time has been reached. There are three basic operating modes available for the function:

- Instant operation: gives the TRIP signal with no additional time delay simultaneously with the START signal.
- Definite time operation (DT): gives the TRIP signal after a user-defined time delay regardless of the measured voltage as long as the voltage is above the  $U_{set}$  value and thus the pick-up element is active (independent time characteristics).
- Inverse definite minimum time (IDMT): gives the TRIP signal after a time which is in relation to the set pick-up voltage  $U_{set}$  and the measured voltage  $U_m$  (dependent time characteristics).

The IDMT function follows this formula:

$$t = \frac{k}{1 - \left(\frac{U_m}{U_s}\right)^a}$$

Where:

- $t$  = operating time
- $k$  = time dial setting
- $U_m$  = measured voltage
- $U_s$  = pick-up setting
- $a$  = IDMT multiplier setting

The following table presents the setting parameters for the function's time characteristics.

Table. 4.4.4 - 51. Setting parameters for operating time characteristics.

Name	Range	Step	Default	Description
Delay type	<ul style="list-style-type: none"> <li>• DT</li> <li>• IDMT</li> </ul>	-	DT	Selection of the delay type time counter. The selection possibilities are dependent (IDMT, Inverse Definite Minimum Time) and independent (DT, Definite Time) characteristics.
Definite operating time delay	0.000...1800.000s	0.005s	0.040s	Definite time operating delay. This setting is active and visible when DT is the selected delay type. When set to 0.000 s, the stage operates as instant stage without added delay. When the parameter is set to 0.005...1800 s, the stage operates as independent delayed.
Time dial setting k	0.01...60.00s	0.01s	0.05s	This setting is active and visible when IDMT is the selected delay type. Time dial/multiplier setting for IDMT characteristics.
IDMT Multiplier	0.01...25.00s	0.01s	1.00s	This setting is active and visible when IDMT is the selected delay type. IDMT time multiplier in the $U_m/U_{set}$ power.

Table. 4.4.4 - 52. Setting parameters for reset time characteristics.

Name	Range	Step	Default	Description
Release time delay	0.000...150.000s	0.005s	0.06s	Resetting time. The time allowed between pick-ups if the pick-up has not led to a trip operation. During this time the START signal is held on for the timers if the delayed pick-up release is active.

Name	Range	Step	Default	Description
Delayed pick-up release	<ul style="list-style-type: none"> <li>No</li> <li>Yes</li> </ul>	-	Yes	Resetting characteristics selection, either time-delayed or instant after the pick-up element is released. If activated, the START signal is reset after a set release time delay.
Time calc reset after release time	<ul style="list-style-type: none"> <li>No</li> <li>Yes</li> </ul>	-	Yes	Operating timer resetting characteristics selection. When activated, the operating time counter is reset after a set release time if the pick-up element is not activated during this time. When disabled, the operating time counter is reset directly after the pick-up element reset.
Continue time calculation during release time	<ul style="list-style-type: none"> <li>No</li> <li>Yes</li> </ul>	-	No	Time calculation characteristics selection. If activated, the operating time counter continues until a set release time even when the pick-up element is reset.

## Events and registers

The undervoltage function (abbreviated "UV" in event block names) generates events and registers from the status changes in the events listed below. The user can select which event messages are stored in the main event buffer: ON, OFF, or both. The events triggered by the function are recorded with a time stamp.

The function's outputs can be used for direct I/O controlling and user logic programming. The function also provides a resettable cumulative counter for the START, TRIP and BLOCKED events.

The function offers four (4) independent stages; the events are segregated for each stage operation.

Table. 4.4.4 - 53. Event messages.

Event block name	Event names
UV1...UV4	Start ON/OFF
UV1...UV4	Trip ON/OFF
UV1...UV4	Block ON/OFF
UV1...UV4	Undervoltage Block ON/OFF

The function registers its operation into the last twelve (12) time-stamped registers; this information is available for all provided instances separately. The register of the function records the ON event process data for START, TRIP or BLOCKED. The table below presents the structure of the function's register content.

Table. 4.4.4 - 54. Register content.

Register	Description
Date and time	dd.mm.yyyy hh:mm:ss.mss
Event	Event name
Fault type	A...A-B-C

Register	Description
Pre-trigger voltage	Start/Trip -20ms voltage
Fault voltage	Start/Trip voltage
Pre-fault voltage	Start -200ms voltage
Trip time remaining	0 ms...1800s
Used SG	Setting group 1...8 active

### 4.4.5 Neutral overvoltage protection (U0>; 59N)

The neutral overvoltage function is used for non-directional instant and time-delayed earth fault protection.

Below is the formula for symmetric component calculation (and therefore to zero sequence voltage calculation).

$$U_0 = 1/3(U_{L1} + U_{L2} + U_{L3})$$

$U_{L1...3}$  = Line to neutral voltages

Below are some examples of zero sequence calculation.

Figure. 4.4.5 - 38. Normal situation.

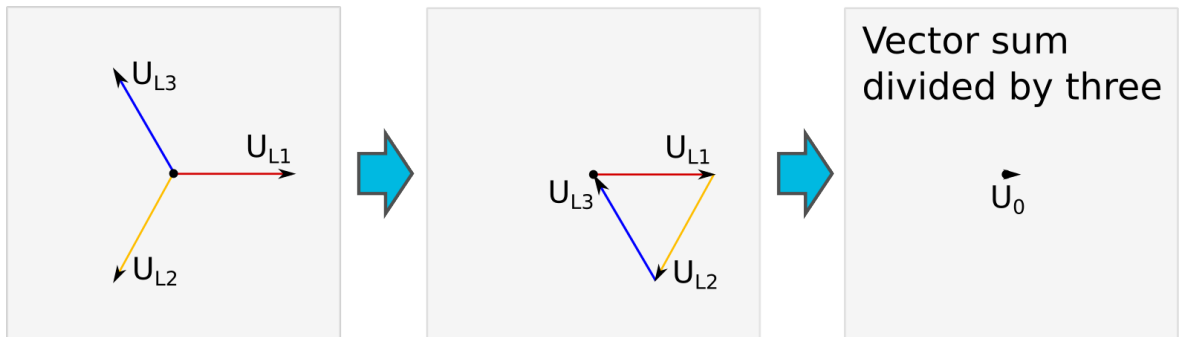

Figure. 4.4.5 - 39. Earth fault in isolated network.

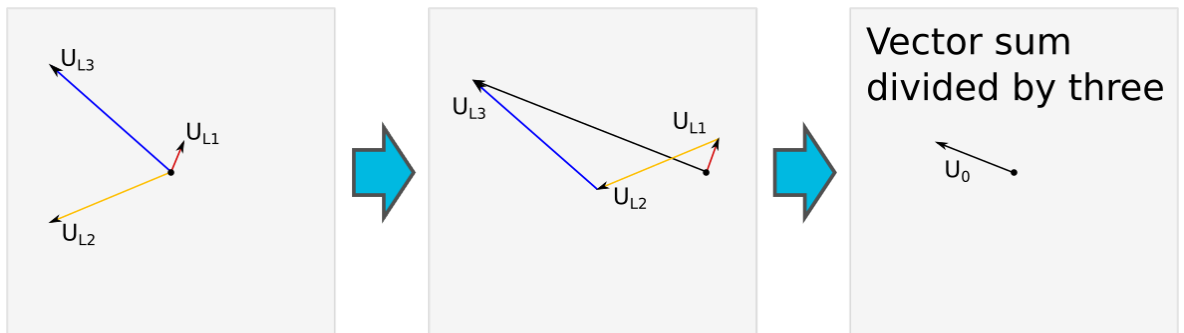

Figure. 4.4.5 - 40. Close-distance short-circuit between phases 1 and 3.

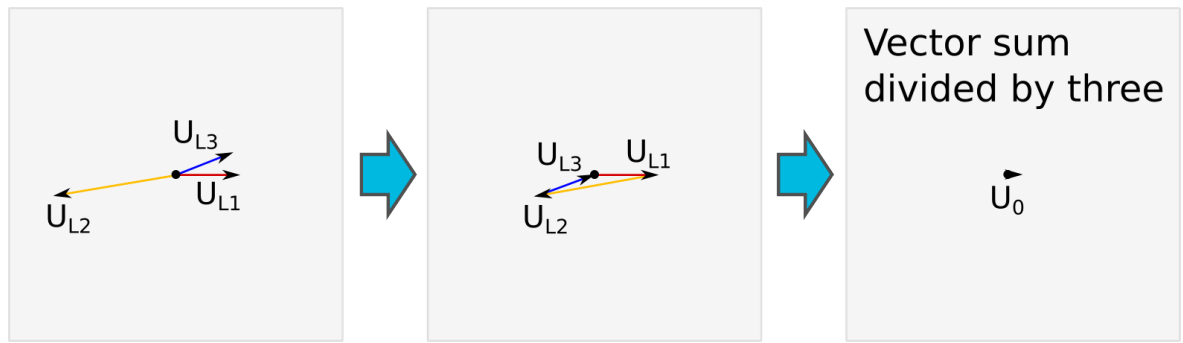
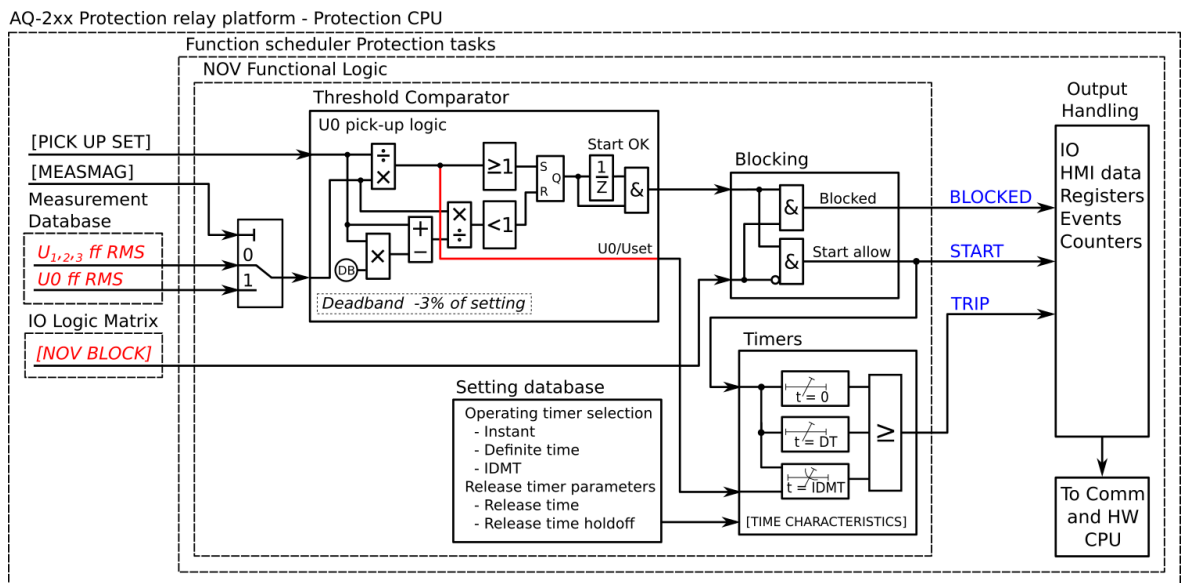

Figure. 4.4.5 - 41. Simplified function block diagram of the U0> function.



### Measured input

The function block uses phase-to-neutral voltage magnitudes or calculated zero sequence component (as the user selects). Neutral overvoltage protection is scaled to line-to-line RMS level. When the line-to-line voltage of a system is 100 V in the secondary side, the earth fault is 100 % of the  $U_n$  and the calculated zero sequence voltage reaches  $100/\sqrt{3} \text{ V} = 57.74 \text{ V}$ .

The selection of the used measurement channel is made with a setting parameter.

Table. 4.4.5 - 55. Measurement inputs of the U0> function.

Signal	Description
U <sub>0</sub> RMS	Fundamental frequency component of U <sub>0</sub> /V voltage measurement
U <sub>L1</sub> RMS	Fundamental frequency component of U <sub>L1</sub> /V voltage measurement
U <sub>L2</sub> RMS	Fundamental frequency component of U <sub>L2</sub> /V voltage measurement
U <sub>L3</sub> RMS	Fundamental frequency component of U <sub>L3</sub> /V voltage measurement

## General settings

The following general settings define the general behavior of the function. These settings are static i.e. it is not possible to change them by editing the setting group.

Table. 4.4.5 - 56. General settings of the function.

Name	Range	Default	Description
U0> LN mode	<ul style="list-style-type: none"> <li>On</li> <li>Blocked</li> <li>Test</li> <li>Test/Blocked</li> <li>Off</li> </ul>	On	Set mode of NOV block. This parameter is visible only when <i>Allow setting of individual LN mode</i> is enabled in <i>General</i> menu.
U0> force status to	<ul style="list-style-type: none"> <li>Normal</li> <li>Start</li> <li>Trip</li> <li>Blocked</li> </ul>	Normal	Force the status of the function. Visible only when <i>Enable stage forcing</i> parameter is enabled in <i>General</i> menu.
U0> meas input select	<ul style="list-style-type: none"> <li>Select</li> <li>U0Calc</li> <li>U3 Input</li> <li>U4 Input</li> </ul>	Select	Defines which available measured magnitude is used by the function. U0Calc calculates the voltage from phase voltages. Please note that U3 Input and U4 Input selections are available only if the channel has been set to U0 mode at <i>Measurements</i> → <i>Transformers</i> → <i>VT module</i> .

## Pick-up settings

The  $U_{set}$  setting parameter controls the pick-up of the U0> function. This defines the maximum allowed measured voltage before action from the function. The function constantly calculates the ratio between the  $U_{set}$  and the measured magnitude ( $U_m$ ) for neutral voltage. The reset ratio of 97 % is built into the function and is always relative to the  $U_{set}$  value. The setting value is common for all measured amplitudes, and when the  $U_m$  exceeds the  $U_{set}$  value it triggers the pick-up operation of the function.

Setting group selection controls the operating characteristics of the function, i.e. the user or user-defined logic can change function parameters while the function is running.

Table. 4.4.5 - 57. Pick-up settings.

Name	Range	Step	Default	Description
Pick-up setting U0set>	1.00...99.00%U <sub>n</sub>	0.01%U <sub>n</sub>	20.00%U <sub>n</sub>	Pick-up setting

## Read-only parameters

The function's *Info* page displays useful, real-time information on the state of the protection function. It is accessed either through the device's HMI display, or through the setting tool software when it is connected to the device and its Live Edit mode is active.

Name	Range	Step	Description
U0> LN mode behaviour	<ul style="list-style-type: none"> <li>On</li> <li>Blocked</li> <li>Test</li> <li>Test/Blocked</li> <li>Off</li> </ul>	-	Displays the mode of NOV block. This parameter is visible only when <i>Allow setting of individual LN mode</i> is enabled in <i>General</i> menu.
U0> Measuring now	<ul style="list-style-type: none"> <li>No U0 avail!</li> <li>U0Calc</li> <li>U3 Input</li> <li>U4 Input</li> </ul>	-	Displays which voltage channel is used by the function. If no voltage channel has been selected the function defaults to calculated residual voltage if line-to-neutral voltages have been connected to device. If no channel is set to "U0" mode and line-to-line voltages are connected, no residual voltage is available and "No U0 avail!" will be displayed.
U0> Pick-up setting	0.0...1 000 000.0V	0.1V	Primary voltage required for tripping. The displayed pick-up voltage level depends on the chosen U0 measurement input selection, on the pick-up settings and on the voltage transformer settings.
Expected operating time	0.000...1800.000s	0.005s	Displays the expected operating time when a fault occurs. When IDMT mode is used, the expected operating time depends on the measured voltage value. If the measured voltage changes during a fault, the expected operating time changes accordingly.
Time remaining to trip	-1800.000...1800.000s	0.005s	When the function has detected a fault and counts down time towards a trip, this displays how much time is left before tripping occurs.
$U_{meas}/U_{set}$ at the moment	0.00...1250.00	0.01	The ratio between the measured or calculated neutral voltage and the pick-up value.

## Function blocking

The blocking signal is evaluated at the start of each program cycle. The blocking signals are connected to the function's dedicated input, which can be configured in the *IO* → *Blocking Input Control* tab of the function.

- When the pick-up element activates and the blocking signal is not active, a START signal is generated, and the function starts or continues with the trip time countdown.
- When the pick-up element activates and the blocking signal is active, a BLOCKED signal is generated, and the function does not process the event further.
- When a START signal is already active and the blocking input signal becomes active, the START signal is reset and BLOCKED signal is generated. The release time characteristics are then processed in the same way as when the pick-up signal is reset.

The blocking signal needs to reach the device minimum of 5 ms before the set operating delay has passed in order for the blocking to activate in time.

## Operating time characteristics for trip and reset

The operating timers' behavior during a function can be set for TRIP signal and also for the release of the function in case the pick-up element is reset before the trip time has been reached. There are three basic operating modes available for the function:

- Instant operation: gives the TRIP signal with no additional time delay simultaneously with the START signal.

- Definite time operation (DT): gives the TRIP signal after a user-defined time delay regardless of the measured or calculated voltage as long as the voltage is above the  $U_{set}$  value and thus the pick-up element is active (independent time characteristics).
- Inverse definite minimum time (IDMT): gives the TRIP signal after a time which is in relation to the set pick-up voltage  $U_{set}$  and the measured voltage  $U_m$  (dependent time characteristics).

The IDMT function follows this formula:

$$t = \frac{k}{\left(\frac{U_m}{U_s}\right)^a - 1}$$

Where:

- $t$  = operating time
- $k$  = time dial setting
- $U_m$  = measured voltage
- $U_s$  = pick-up setting
- $a$  = IDMT multiplier setting

The following table presents the setting parameters for the function's time characteristics.

Table. 4.4.5 - 58. Setting parameters for operating time characteristics.

Name	Range	Step	Default	Description
Delay type	DT IDMT	-	DT	Selection of the delay type time counter. The selection possibilities are dependent (IDMT, Inverse Definite Minimum Time) and independent (DT, Definite Time) characteristics.
Definite operating time delay	0.000...1800.000s	0.005s	0.040s	Definite time operating delay. The setting is active and visible when DT is the selected delay type. When set to 0.000 s, the stage operates as instant without added delay. When the parameter is set to 0.005...1800 s, the stage operates as independent delayed.
Time dial setting k	0.01...60.00s	0.01s	0.05s	The setting is active and visible when IDMT is the selected delay type. Time dial/multiplier setting for IDMT characteristics.
IDMT Multiplier	0.01...25.00s	0.01s	1.00s	The setting is active and visible when IDMT is the selected delay type. IDMT time multiplier in the $U_m/U_{set}$ power.

Table. 4.4.5 - 59. Setting parameters for reset time characteristics.

Name	Range	Step	Default	Description
Release time delay	0.000...150.000s	0.005s	0.06s	Resetting time. Time allowed between pick-ups if the pick-up has not led to a trip operation. During this time the START signal is held on for the timers if the delayed pick-up release is active.
Delayed pick-up release	<ul style="list-style-type: none"> <li>• No</li> <li>• Yes</li> </ul>	-	Yes	Resetting characteristics selection either as time-delayed or as instant after the pick-up element is released. If activated, the START signal is reset after a set release time delay.

Name	Range	Step	Default	Description
Time calc reset after release time	<ul style="list-style-type: none"> <li>No</li> <li>Yes</li> </ul>	-	Yes	Operating timer resetting characteristics selection. When active, the operating time counter is reset after a set release time if the pick-up element is not activated during this time. When disabled, the operating time counter is reset directly after the pick-up element reset.
Continue time calculation during release time	<ul style="list-style-type: none"> <li>No</li> <li>Yes</li> </ul>	-	No	Time calculation characteristics selection. If activated, the operating time counter continues until a set release time has passed even if the pick-up element is reset.

The user can reset characteristics through the application. The default setting is a 60 ms delay; the time calculation is held during the release time.

In the release delay option the operating time counter calculates the operating time during the release. When using this option the function does not trip if the input signal is not re-activated while the release time count is on-going.

## Events and registers

The neutral overvoltage function (abbreviated "NOV" in event block names) generates events and registers from the status changes in the events listed below. The user can select which event messages are stored in the main event buffer: ON, OFF, or both. The events triggered by the function are recorded with a time stamp.

The function's outputs can be used for direct I/O controlling and user logic programming. The function also provides a cumulative counter for the START, TRIP and BLOCKED events.

The function offers four (4) independent stages; the events are segregated for each stage operation.

Table. 4.4.5 - 60. Event messages.

Event block name	Event names
NOV1...NOV4	Start ON/OFF
NOV1...NOV4	Trip ON/OFF
NOV1...NOV4	Block ON/OFF

The function registers its operation into the last twelve (12) time-stamped registers; this information is available for all provided instances separately. The register of the function records the ON event process data for START, TRIP or BLOCKED. The table below presents the structure of the function's register content.

Table. 4.4.5 - 61. Register content.

Register	Description
Date and time	dd.mm.yyyy hh:mm:ss.mss
Event	Event name
Fault type	L1-G...L1-L2-L3

Register	Description
Pre-trigger voltage	Start/Trip -20ms voltage
Fault voltage	Start/Trip voltage
Pre-fault voltage	Start -200ms voltage
Trip time remaining	0 ms...1800s
Setting group in use	Setting group 1...8 active

#### 4.4.6 Sequence voltage protection ( $U_1/U_2 > / <$ ; 47/27P/59PN)

The sequence voltage function is used for instant and time-delayed voltage protection. It has positive and negative sequence protection for both overvoltage and undervoltage (the user selects the needed function). The user can select the voltage used. Sequence voltage is based on the system's line-to-line voltage level. Protection stages can be set to protect against either undervoltage or overvoltage.

##### Positive sequence voltage calculation

Below is the formula for symmetric component calculation (and therefore to positive sequence voltage calculation).

$$U_1 = \frac{1}{3}(U_{L1} + aU_{L2} + a^2U_{L3})$$

$$a = 1 \angle 120^\circ$$

$$a^2 = 1 \angle 240^\circ$$

$U_{L1...3}$  = Line to neutral voltages

In what follows are three examples of positive sequence calculation (positive sequence component vector).

Figure. 4.4.6 - 42. Normal situation.

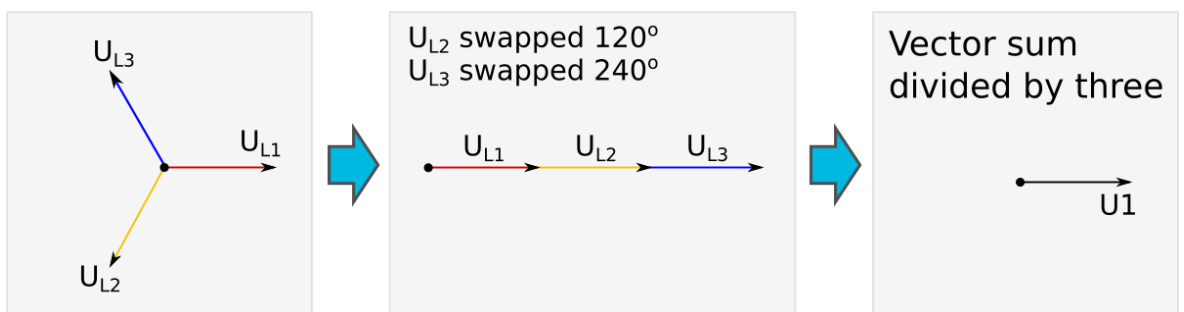

Figure. 4.4.6 - 43. Earth fault in an isolated network.

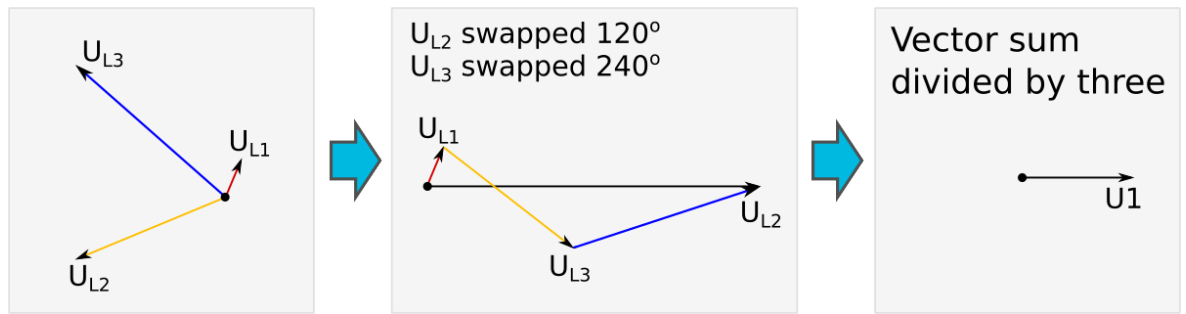
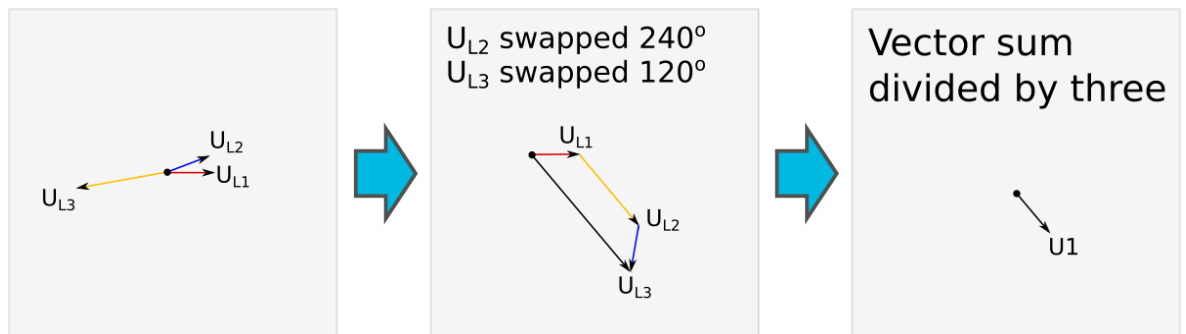

Figure. 4.4.6 - 44. Close-distance short-circuit between phases 1 and 3.



### Negative sequence voltage calculation

Below is the formula for symmetric component calculation (and therefore to negative sequence voltage calculation).

$$U_2 = \frac{1}{3} (U_{L1} + a^2 U_{L2} + a U_{L3})$$

$$a = 1 \angle 120^\circ$$

$$a^2 = 1 \angle 240^\circ$$

$U_{L1...3}$  = Line to neutral voltages

In what follows are three examples of negative sequence calculation (negative sequence component vector).

Figure. 4.4.6 - 45. Normal situation.

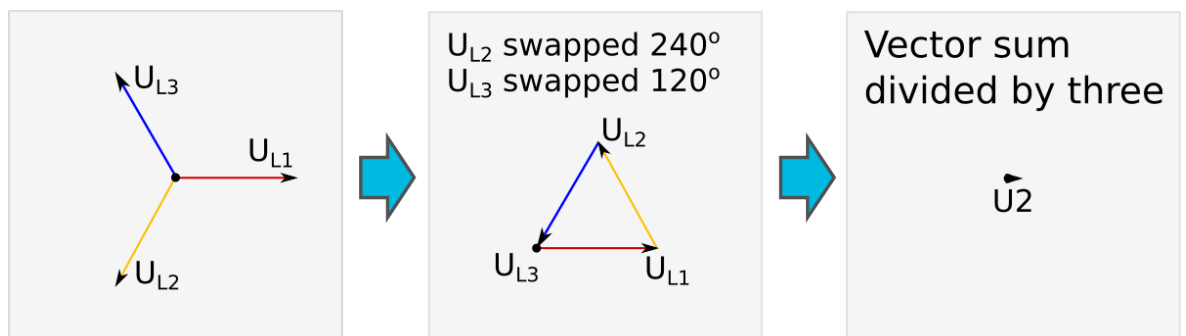

Figure. 4.4.6 - 46. Earth fault in isolated network.

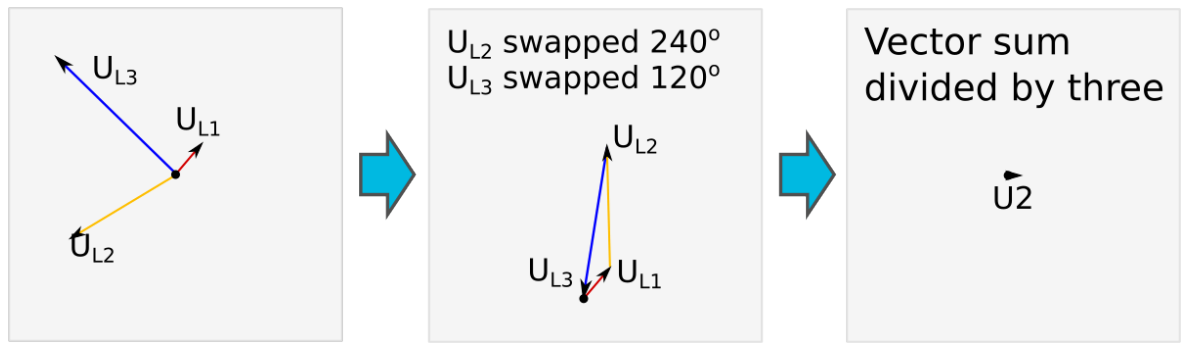

Figure. 4.4.6 - 47. Close-distance short-circuit between phases 1 and 3.

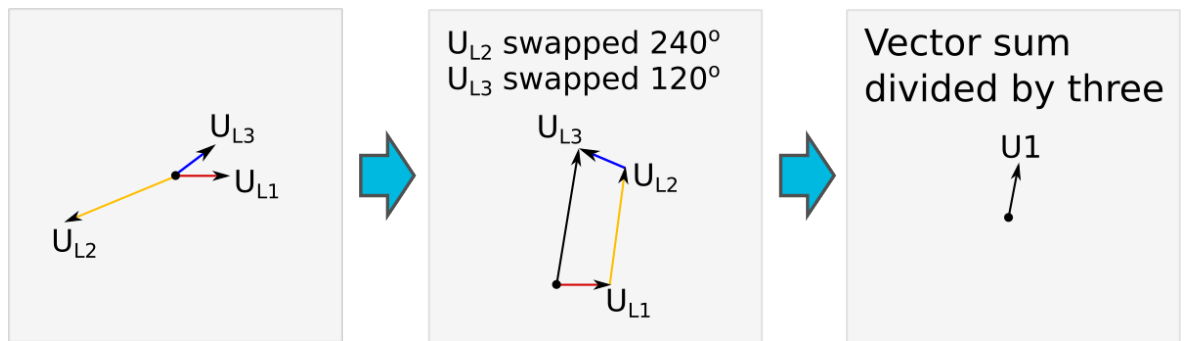
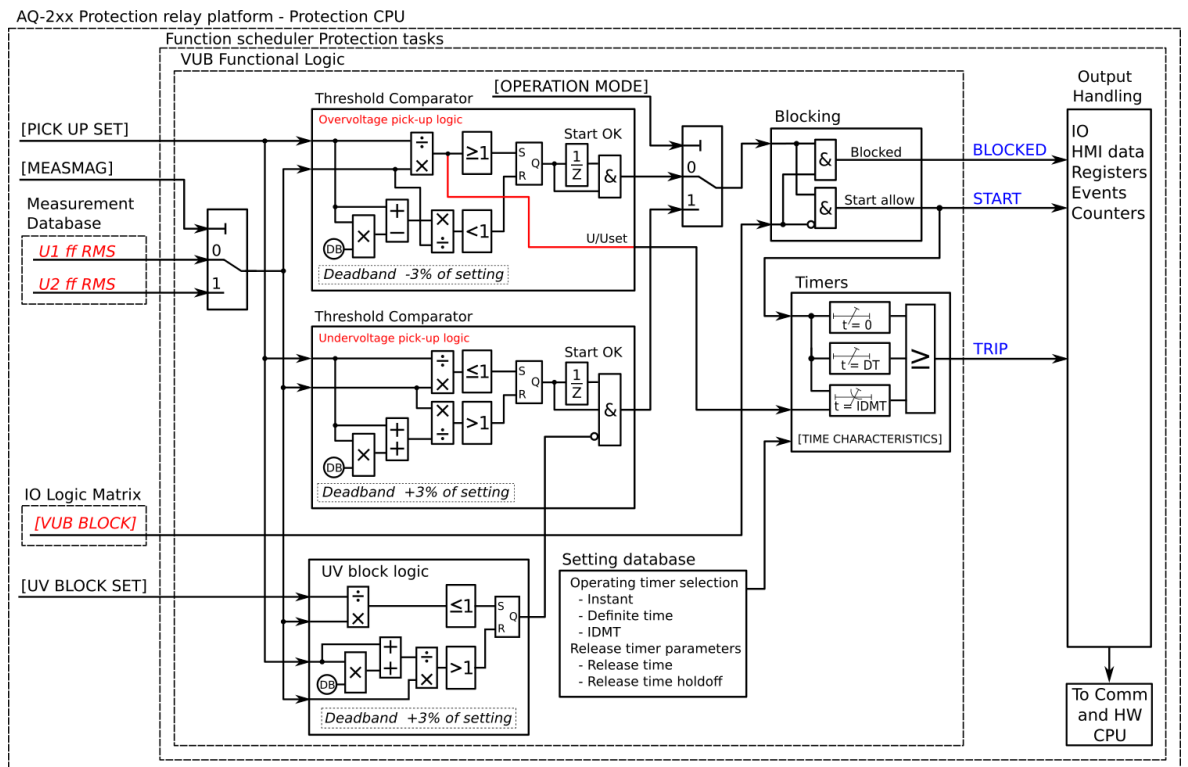

Figure. 4.4.6 - 48. Simplified function block diagram of the U1/U2>/< function.



## Measured input

The function block uses fundamental frequency component of phase-to-phase, phase-to-neutral and zero sequence voltage measurements. The user can select the monitored magnitude to be either positive sequence voltage or negative sequence voltage values.

Table. 4.4.6 - 62. Measurement inputs of the U1/U2>/< function.

Signal	Description
U <sub>1</sub> RMS	Fundamental frequency component of U <sub>1</sub> /V voltage channel
U <sub>2</sub> RMS	Fundamental frequency component of U <sub>2</sub> /V voltage channel
U <sub>3</sub> RMS	Fundamental frequency component of U <sub>3</sub> /V voltage channel
U <sub>4</sub> RMS	Fundamental frequency component of U <sub>4</sub> /V voltage channel

## General settings

The following general settings define the general behavior of the function. These settings are static i.e. it is not possible to change them by editing the setting group.

Table. 4.4.6 - 63. General settings of the function.

Name	Range	Default	Description
U1/2 >/< LN mode	<ul style="list-style-type: none"> <li>On</li> <li>Blocked</li> <li>Test</li> <li>Test/Blocked</li> <li>Off</li> </ul>	On	Set mode of VUB block. This parameter is visible only when <i>Allow setting of individual LN mode</i> is enabled in <i>General</i> menu.
U1/2 >/< force status to	<ul style="list-style-type: none"> <li>Normal</li> <li>Start</li> <li>Trip</li> <li>Blocked</li> </ul>	Normal	Force the status of the function. Visible only when <i>Enable stage forcing</i> parameter is enabled in <i>General</i> menu.
Measured magnitude	<ul style="list-style-type: none"> <li>U1 Positive sequence voltage</li> <li>U2 Negative sequence voltage</li> </ul>	U1 Positive sequence voltage	Selects which calculated voltage is supervised.

## Pick-up settings

The  $U_{set}$  setting parameter controls the pick-up of the U1/U2>/< function. This defines the maximum or minimum allowed calculated U1 or U2 voltage before action from the function. The function constantly calculates the ratio between the  $U_{set}$  and the calculated U1 or U2 magnitude ( $U_C$ ). The monitored voltage is chosen in the *Info* page with the parameter *Measured magnitude*. The reset ratio of 97 % in overvoltage applications is built into the function and is always relative to the  $U_{set}$  value. The reset ratio of 103 % in undervoltage applications is built into the function and is always relative to the  $U_{set}$  value. When the  $U_C$  goes above or below the  $U_{set}$  value it triggers the pick-up operation of the function.

Setting group selection controls the operating characteristics of the function, i.e. the user or user-defined logic can change function parameters while the function is running.

Table. 4.4.6 - 64. Pick-up settings.

Name	Range	Step	Default	Description
Pick-up terms	<ul style="list-style-type: none"> <li>Over &gt;</li> <li>Under &lt;</li> </ul>	-	Over >	Selects whether the function picks-up when the monitored voltage is under or over the set pick-up value.
$U_{set}$	5.00...150.00% $U_n$	0.01% $U_n$	105% $U_n$	Pick-up setting
$U_{blk}$	0.00...80.00% $U_n$	0.01% $U_n$	5% $U_n$	Undervoltage blocking (visible when the pick-up term is Under <)

### Using *Block setting* to prevent nuisance trips

It is recommended to use the *Under block setting*  $U_{blk}$  parameter when Under < is the chosen tripping condition to prevent the function from tripping in a situation where the network is de-energized. When the measured voltage drops below the set value, the function does not give a tripping signal. If the measured voltage has dropped below the *Under block setting*  $U_{blk}$  parameter, the blocking continues until all of the line voltages have increased above the  $U_{<}$  pick-up setting. Please see the image below for a visualization of this function. If the block level is set to zero (0), blocking is not in use.

Figure. 4.4.6 - 49. Example of the block setting operation.

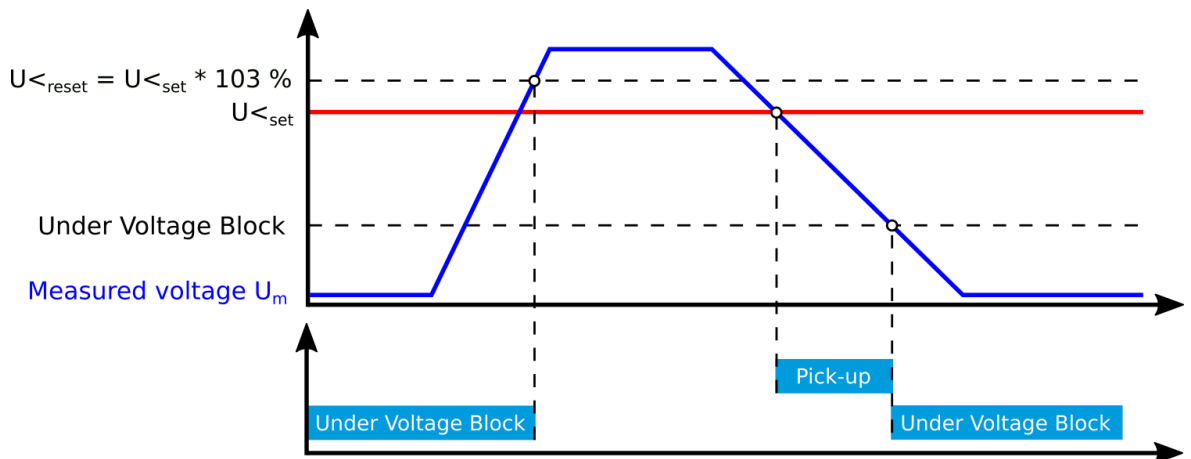

### Read-only parameters

The function's *Info* page displays useful, real-time information on the state of the protection function. It is accessed either through the device's HMI display, or through the setting tool software when it is connected to the device and its Live Edit mode is active.

Table. 4.4.6 - 65. Information displayed by the function.

Name	Range	Step	Description
U1/2 >/< LN behaviour	<ul style="list-style-type: none"> <li>On</li> <li>Blocked</li> <li>Test</li> <li>Test/Blocked</li> <li>Off</li> </ul>	-	Displays the mode of VUB block. This parameter is visible only when <i>Allow setting of individual LN mode</i> is enabled in <i>General</i> menu.

Name	Range	Step	Description
U1/2 >/< Pick-up setting	0.0...1 000 000.0V	0.1V	The primary voltage required for tripping. The displayed pick-up voltage level depends on the pick-up setting and the voltage transformer settings.
Expected operating time	0.000...1800.000s	0.005s	Displays the expected operating time when a fault occurs. When IDMT mode is used, the expected operating time depends on the measured voltage value. If the measured voltage changes during a fault, the expected operating time changes accordingly.
Time remaining to trip	-1800.000...1800.000s	0.005s	When the function has detected a fault and counts down time towards a trip, this displays how much time is left before tripping occurs.
$U_{meas}/U_{set}$ at the moment	0.00...1250.00 $U_m/U_{set}$	0.01 $U_m/U_{set}$	The ratio between the measured voltage and the pick-up value.

### Function blocking

The blocking signal is evaluated at the start of each program cycle. The blocking signals are connected to the function's dedicated input, which can be configured in the *IO* → *Blocking Input Control* tab of the function.

- When the pick-up element activates and the blocking signal is not active, a START signal is generated, and the function starts or continues with the trip time countdown.
- When the pick-up element activates and the blocking signal is active, a BLOCKED signal is generated, and the function does not process the event further.
- When a START signal is already active and the blocking input signal becomes active, the START signal is reset and BLOCKED signal is generated. The release time characteristics are then processed in the same way as when the pick-up signal is reset.

The blocking signal needs to reach the device minimum of 5 ms before the set operating delay has passed in order for the blocking to activate in time.

### Operating time characteristics for trip and reset

The operating timers' behavior during a function can be set for TRIP signal and also for the release of the function in case the pick-up element is reset before the trip time has been reached. There are three basic operating modes available for the function:

- Instant operation: gives the TRIP signal with no additional time delay simultaneously with the START signal.
- Definite time operation (DT): gives the TRIP signal after a user-defined time delay regardless of the measured or calculated voltage as long as the voltage is above the  $U_{set}$  value and thus the pick-up element is active (independent time characteristics).
- Inverse definite minimum time (IDMT): gives the TRIP signal after a time which is in relation to the set pick-up voltage  $U_{set}$  and the measured voltage  $U_m$  (dependent time characteristics).

The IDMT function follows one of the following formulas:

$$\begin{array}{cc}
 \text{Overvoltage} & \text{Undervoltage} \\
 t = \frac{k}{\left(\frac{U_m}{U_s}\right)^a - 1} & t = \frac{k}{1 - \left(\frac{U_m}{U_s}\right)^a}
 \end{array}$$

Where:

- $t$  = operating time
- $k$  = time dial setting
- $U_m$  = measured voltage
- $U_s$  = pick-up setting
- $a$  = IDMT multiplier setting

The following table presents the setting parameters for the function's time characteristics.

Table. 4.4.6 - 66. Setting parameters for operating time characteristics.

Name	Range	Step	Default	Description
Delay type	<ul style="list-style-type: none"> <li>• DT</li> <li>• IDMT</li> </ul>	-	DT	Selection of the delay type time counter. The selection possibilities are dependent (IDMT, Inverse Definite Minimum Time) and independent (DT, Definite Time) characteristics.
Definite operating time delay	0.000...1800.000s	0.005s	0.040s	Definite time operating delay. The setting is active and visible when DT is the selected delay type. When set to 0.000 s, the stage operates as instant without added delay. When the parameter is set to 0.005...1800 s, the stage operates as independent delayed.
Time dial setting k	0.01...60.00s	0.01s	0.05s	The setting is active and visible when IDMT is the selected delay type. Time dial/multiplier setting for IDMT characteristics.
IDMT Multiplier	0.01...25.00s	0.01s	1.00s	The setting is active and visible when IDMT is the selected delay type. IDMT time multiplier in the $U_m/U_{set}$ power.

Table. 4.4.6 - 67. Setting parameters for reset time characteristics.

Name	Range	Step	Default	Description
Release time delay	0.000...150.000s	0.005s	0.06s	Resetting time. Time allowed between pick-ups if the pick-up has not led to a trip operation. During this time the START signal is held on for the timers if the delayed pick-up release is active.
Delayed pick-up release	<ul style="list-style-type: none"> <li>• No</li> <li>• Yes</li> </ul>	-	Yes	Resetting characteristics selection either as time-delayed or as instant after the pick-up element is released. If activated, the START signal is reset after a set release time delay.
Time calc reset after release time	<ul style="list-style-type: none"> <li>• No</li> <li>• Yes</li> </ul>	-	Yes	Operating timer resetting characteristics selection. When active, the operating time counter is reset after a set release time if the pick-up element is not activated during this time. When disabled, the operating time counter is reset directly after the pick-up element reset.
Continue time calculation during release time	<ul style="list-style-type: none"> <li>• No</li> <li>• Yes</li> </ul>	-	No	Time calculation characteristics selection. If activated, the operating time counter continues until a set release time has passed even if the pick-up element is reset.

The user can reset characteristics through the application. The default setting is a 60 ms delay; the time calculation is held during the release time.

In the release delay option the operating time counter calculates the operating time during the release. When using this option the function does not trip if the input signal is not re-activated while the release time count is on-going.

## Events and registers

The sequence voltage function (abbreviated "VUB" in event block names) generates events and registers from the status changes in the events listed below. The user can select which event messages are stored in the main event buffer: ON, OFF, or both. The events triggered by the function are recorded with a time stamp.

The function's outputs can be used for direct I/O controlling and user logic programming. The function also a resettable cumulative counter for the START, TRIP and BLOCKED events.

The function offers four (4) independent stages; the events are segregated for each stage operation.

Table. 4.4.6 - 68. Event messages.

Event block name	Event names
VUB1...VUB4	Start ON/OFF
VUB1...VUB4	Trip ON/OFF
VUB1...VUB4	Block ON/OFF

The function registers its operation into the last twelve (12) time-stamped registers; this information is available for all provided instances separately. The register of the function records the ON event process data for START, TRIP or BLOCKED. The table below presents the structure of the function's register content.

Table. 4.4.6 - 69. Register content.

Register	Description
Date and time	dd.mm.yyyy hh:mm:ss.mss
Event	Event name
Pre-trigger voltage	Start/Trip -20ms voltage
Fault voltage	Start/Trip voltage
Pre-fault voltage	Start -200ms voltage
Trip time remaining	0 ms...1800s
Setting group in use	Setting group 1...8 active

## 4.4.7 Low-voltage ride-through (27T)

Low-voltage ride-through (LVRT), is the capability of electric smaller generators to stay connected in short periods of voltage sags due to faults or similar phenomena's in network. It is mostly needed at distribution level (wind parks, PV systems, distributed cogeneration, etc.) to prevent a short circuit at HV or EHV level from causing a widespread loss of power generation. Similar requirements for critical loads such as computer systems and industrial processes are often handled with an uninterruptible power supply (UPS) or capacitor bank to supply make-up power during these events.

### Concept

Many generator designs use electric current flowing through windings to produce the magnetic field on which the motor or generator operates. This is in contrast to designs that use permanent magnets to generate this field instead. Such devices may have a minimum working voltage, below which the device does not work correctly, or does so at greatly reduced efficiency. Some will disconnect themselves from the circuit when these conditions apply. The effect is more pronounced in doubly fed induction generators, which have two sets of powered magnetic windings, than in squirrel-cage induction generators, which have only one. Synchronous generators may slip and become unstable, if the voltage of the stator winding goes below a certain threshold.

### Avoid larger blackouts

In a grid containing many distributed generators subject to disconnection at under voltage, it is possible to cause a chain reaction that takes other generators offline in the process. This can occur in the event of a voltage dip that causes one of the generators to disconnect from the grid. As voltage dips are often caused by too little generation for the load in a distribution grid, removing generation can cause the voltage to drop further. This may bring the voltage down enough to cause another generator to trip, lower the voltage even further, and may cause a cascading failure.

Figure. 4.4.7 - 50. Operating principle of the low-voltage ride-through protection function.

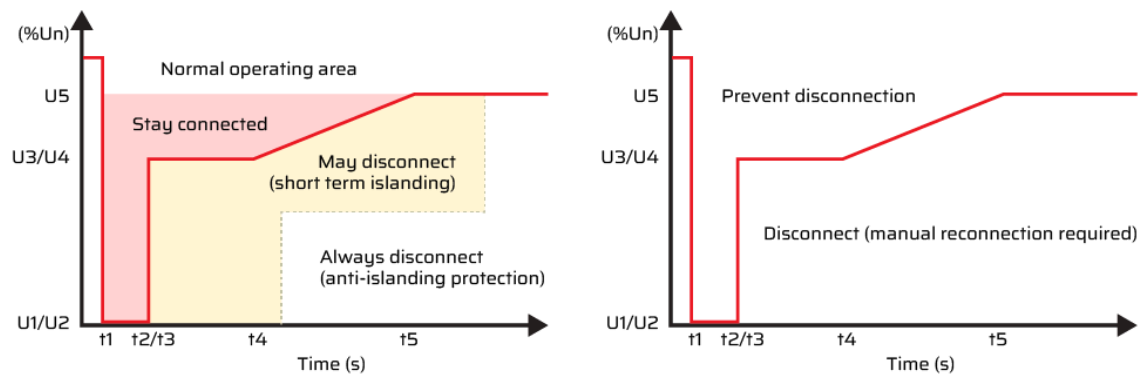

### Ride-through systems

Modern wind turbines, typically 1 MW and larger, are normally required to include systems that allow them to operate through such an event, and thereby “ride through” the voltage dip. Similar requirements are now becoming common on large solar power installations that likewise might cause instability in the event of a widespread disconnection of generating units. Depending on the application the device may, during and after the dip, be required to:

- Disconnect and stay disconnected until manually ordered to reconnect.
- Disconnect temporarily from the grid, but reconnect and continue operation after the dip.
- Stay operational and not disconnect from the grid.
- Stay connected and support the grid with reactive power.

## Measured input

The function block uses the fundamental frequency component of line-to-line or line-to-neutral (as the user selects). LVRT protection uses  $U_{L12}$  and  $U_{L23}$  line-to-line voltages to measure the network voltage level. In line-to-earth voltage measurement mode all three voltages  $U_{L1}$ ,  $U_{L2}$  and  $U_{L3}$  have to be connected. In line-to-line voltage measurement connection, at least the voltages  $U_{L12}$  and  $U_{L23}$  must be connected to the device.

Figure. 4.4.7 - 51. RMS average of measured line-to-line voltages used for protection.

$$\frac{U_{L12} + U_{L23}}{2}$$

Table. 4.4.7 - 70. Measurement inputs of the LVRT function.

Signal	Description
$U_{L12RMS}$	Fundamental frequency component of $U_{L12}/V$ voltage measurement
$U_{L23RMS}$	Fundamental frequency component of $U_{L23}/V$ voltage measurement
$U_{L31RMS}$	Fundamental frequency component of $U_{L31}/V$ voltage measurement
$U_{L1RMS}$	Fundamental frequency component of $U_{L1}/V$ voltage measurement
$U_{L2RMS}$	Fundamental frequency component of $U_{L2}/V$ voltage measurement
$U_{L3RMS}$	Fundamental frequency component of $U_{L3}/V$ voltage measurement

## General settings

The following general settings define the general behavior of the function. These settings are static i.e. it is not possible to change them by editing the setting group.

Table. 4.4.7 - 71. General settings of the function.

Name	Range	Default	Description
LVRT LN mode	<ul style="list-style-type: none"> <li>On</li> <li>Blocked</li> <li>Test</li> <li>Test/Blocked</li> <li>Off</li> </ul>	<ul style="list-style-type: none"> <li>On</li> </ul>	Set mode of LVRT block. This parameter is visible only when <i>Allow setting of individual LN mode</i> is enabled in <i>General</i> menu.
LVRT force status to	<ul style="list-style-type: none"> <li>Normal</li> <li>Start</li> <li>Trip</li> <li>Blocked</li> <li>Undervolt</li> <li>Blk On</li> </ul>	<ul style="list-style-type: none"> <li>Normal</li> </ul>	Force the status of the function. Visible only when <i>Enable stage forcing</i> parameter is enabled in <i>General</i> menu.

## Read-only parameters

The function's *Info* page displays useful, real-time information on the state of the protection function. It is accessed either through the device's HMI display, or through the setting tool software when it is connected to the device and its Live Edit mode is active.

Table. 4.4.7 - 72. Information displayed by the function.

Name	Range	Step	Description
LVRT LN behaviour	<ul style="list-style-type: none"> <li>• On</li> <li>• Blocked</li> <li>• Test</li> <li>• Test/Blocked</li> <li>• Off</li> </ul>	-	Displays the mode of LVRT block. This parameter is visible only when <i>Allow setting of individual LN mode</i> is enabled in <i>General</i> menu.
LVRT condition	<ul style="list-style-type: none"> <li>• Normal</li> <li>• Start</li> <li>• Trip</li> <li>• Blocked</li> <li>• Undervolt Blk On</li> </ul>	-	Displays status of the protection function.
Measured voltage (U12+U23 avg)	0.00...1250.00 %Un	0.01 %Un	Measured line-to-line voltage average.
Umeas / Fault release>	0.00...1250.00 Um/Uset	0.01 Um/Uset	Measured voltage compared to hysteresis setting.
Umeas / Fault start <	0.00...1250.00 Um/Uset	0.01 Um/Uset	Measured voltage compared to pickup setting.
Fault on timer	0.000...1800.000s	0.005s	How long timer has been running since voltage dropped below pickup limit.

## Pick-up settings

Setting group selection controls the operating characteristics of the function, i.e. the user or user-defined logic can change function parameters while the function is running. Stage-related settings are described below.

Figure. 4.4.7 - 52. LVRT characteristic with three setting plots.

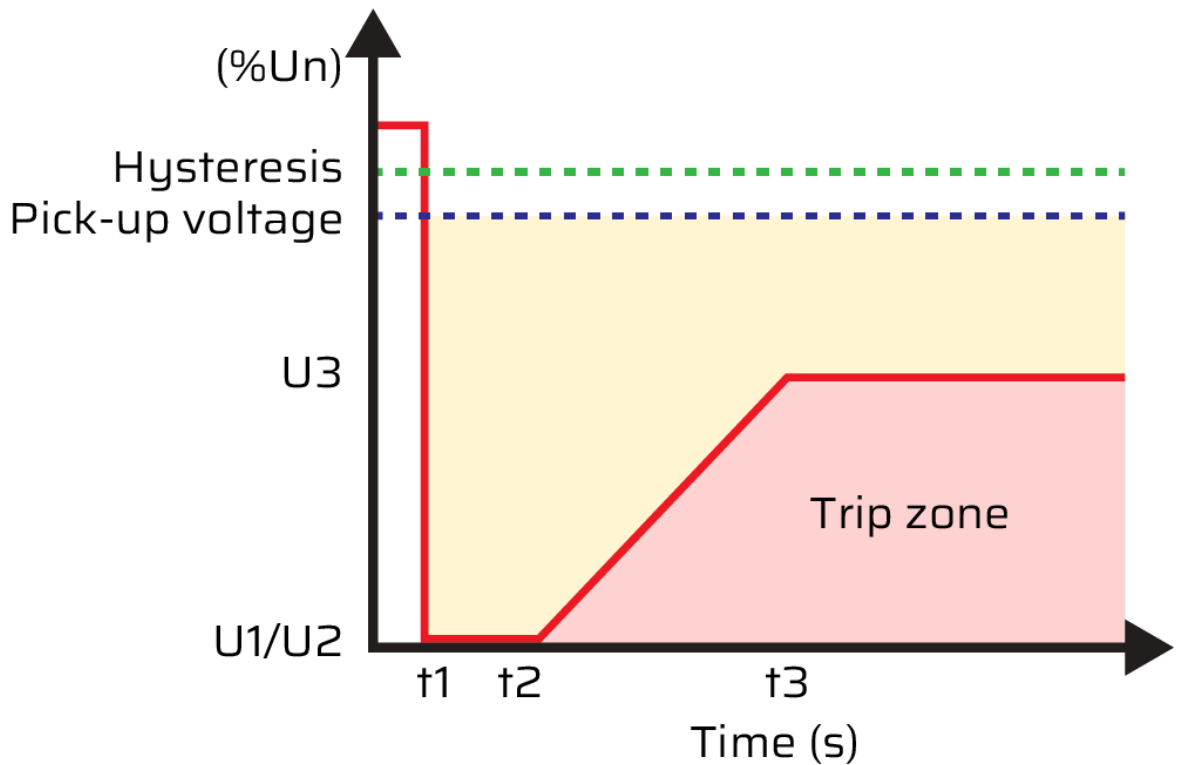

Table. 4.4.7 - 73. Pick-up settings.

Name	Range	Step	Default	Description
Fault start<	50.00...120.00 %Un	0.01 %Un	87 %Un	LVRT characteristic pickup voltage level activates fault timer.
Fault reset	50.00...120.00 %Un	0.01 %Un	93 %Un	Timer resets once network voltage increases above hysteresis setting. Fault reset> must be set higher than fault< setting.
Low voltage block limit	0.00...80.00 %Un	0.01 %Un	10.00 %Un	Voltage descending below low voltage block limit sets the LVRT to blocked state. In case voltage block is not wanted, set the value to 0%.
Numer of knee points	2...10	1	3	Determine how many knee points the LVRT characteristic has. Each knee point has individual voltage and time settings.
Amplitude plot [1...10]	0.00...120.00 %Un	0.01 %Un	0.00 %Un	Amplitude setting for trip zone at the first knee point. Measured voltage has to fall below this limit to trip LVRT stage.
Time plot [1...10]	0.100...1800.000 s	0.005 s	-	First knee point time setting is set to 0 seconds as a fixed value.
Time plot [2...10]	0.100...1800.000 s	0.005 s	-	Continue building LVRT characteristic with another plot and settings.

## LVRT operating principle

From the grid operator's point of view, an LVRT profile defines a voltage profile that a distributed energy resource being connected to the grid should be able to ride through, in case of a low voltage event (voltage dip). The distributed energy resource is only allowed to disconnect from the grid if the voltage at the point of common coupling drops below the LVRT borderline. In other words, a LVRT protection function is a time-dependent voltage supervision according to a predefined voltage profile. The time-dependent voltage supervision is started as soon as the voltage at the point of common coupling falls below the Umeas/Fault start< voltage level. Voltage drop/sag is considered to be over once voltage returns back to normal level, which in this case is considered higher than Umeas/Fault release> setting.

The LVRT module is designed for distributed generation resources that operate in parallel with the grid. It supervises system voltage disturbances by comparing them with a configurable voltage profile that is triggered once the system voltage falls below a configurable start value Umeas/Fault start<.

Once triggered, the LVRT module supervises the system voltage consecutively and determines if the voltage excursion is above or below of the preset voltage profile. A trip signal is only issued if the voltage excursion exits the "Ride-through" region and goes into the "Tripping" region.

## Function blocking

The blocking signal is evaluated at the start of each program cycle. The blocking signals are connected to the function's dedicated input, which can be configured in the *IO* → *Blocking Input Control* tab of the function.

- When the pick-up element activates and the blocking signal is not active, a START signal is generated, and the function starts or continues with the trip time countdown.
- When the pick-up element activates and the blocking signal is active, a BLOCKED signal is generated, and the function does not process the event further.
- When a START signal is already active and the blocking input signal becomes active, the START signal is reset and BLOCKED signal is generated. The release time characteristics are then processed in the same way as when the pick-up signal is reset.

The blocking signal needs to reach the device minimum of 5 ms before the set operating delay has passed in order for the blocking to activate in time.

## Events and registers

The low-voltage ride-through function (abbreviated "LVRT" in event block names) generates events and registers from the status changes in the events listed below. The user can select which event messages are stored in the main event buffer: ON, OFF, or both. The events triggered by the function are recorded with a time stamp.

The function's output can be used for direct I/O controlling and user logic programming. The function also provides a resettable cumulative counter for the START, TRIP and BLOCKED events.

Table. 4.4.7 - 74. Event messages.

Event block name	Event names
LVRT1	Vstart< ON/OFF
LVRT1	Vtrip ON/OFF
LVRT1	LVRT Block ON/OFF
LVRT1	LVRT UV Block ON/OFF

The function registers its operation into the last twelve (12) time-stamped registers; this information is available for all provided instances separately. The register of the function records the ON event process data for START, TRIP or BLOCKED. The table below presents the structure of the function's register content.

Table. 4.4.7 - 75. Register content.

Name	Description
Date and time	dd.mm.yyyy hh:mm:ss.mss
Event	Event name
Fault type	<ul style="list-style-type: none"> <li>• A(AB)</li> <li>• B(BC)</li> <li>• A-B(AB-BC)</li> <li>• C(CA)</li> <li>• A-C(AB-CA)</li> <li>• B-C(BC-CA)</li> <li>• A-B-C</li> </ul>
Voltage ABC Pre-trig	Start/Trip -20ms voltage
Trip time remaining	0 ms...1800s
Setting group in use	Setting group 1...8 active.
Voltage ABC prefault	Start -200ms voltage

#### 4.4.8 Overfrequency and underfrequency protection ( $f > / <$ ; 81O/81U)

The frequency protection function can be used both in overfrequency and in underfrequency situations, and it has four (4) stages for both. Frequency protection can be applied to protect feeder, bus, transformer, motor and generator applications. The difference between the generated power and the load demand can cause the frequency to drop below or rise above the allowed level. When the consumption is larger than the generated power, the frequency may drop. When more power is generated than is consumed, overfrequency can occur.

In generator applications too big a load or a malfunction in the power controller can cause the frequency to decrease. Underfrequency causes damage to turbine wings through vibration as well as heating due to increased iron losses, dropped cooling efficiency and over-magnetization in step-up transformers. Overfrequency protection prevents the generator from running too fast which can cause damage to the generator turbine.

Underfrequency and overfrequency protection can be used as an indicator of an accidental island operation in distributed generation and in some consumers (as it is unlikely that the consumed and generated power are the same). Overfrequency is also often used to control power generation to keep the system's frequency consistent.

Each stage can be activated and deactivated individually. After the  $f > / <$  mode has been activated (*Protection* → *Stage activation* → *Frequency stages*), the user can activate and deactivate the individual stages at will (*Protection* → *Frequency* → *Frequency protection  $f > / <$*  → *INFO* → *Stage operational setup*).

Figure. 4.4.8 - 53. Simplified function block diagram of the  $f >$  function.

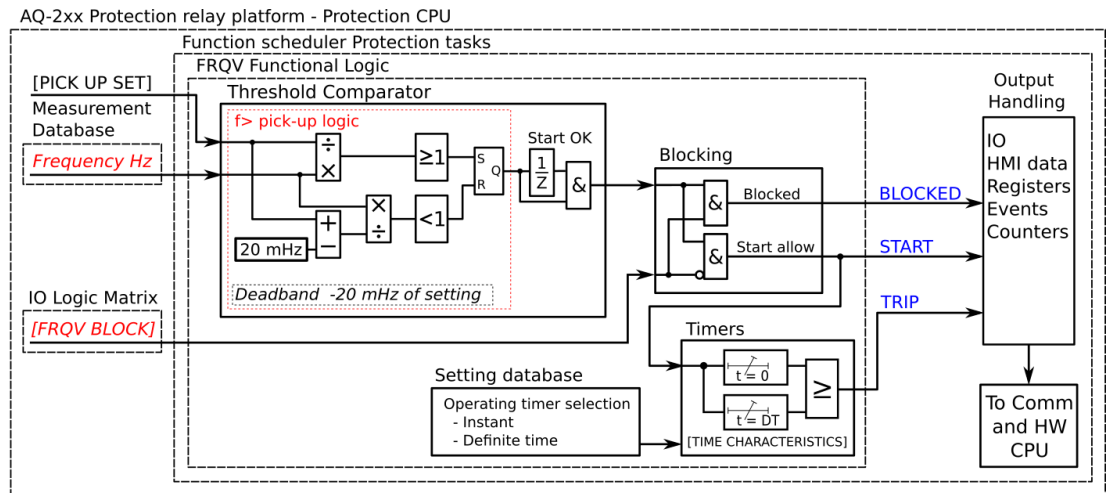
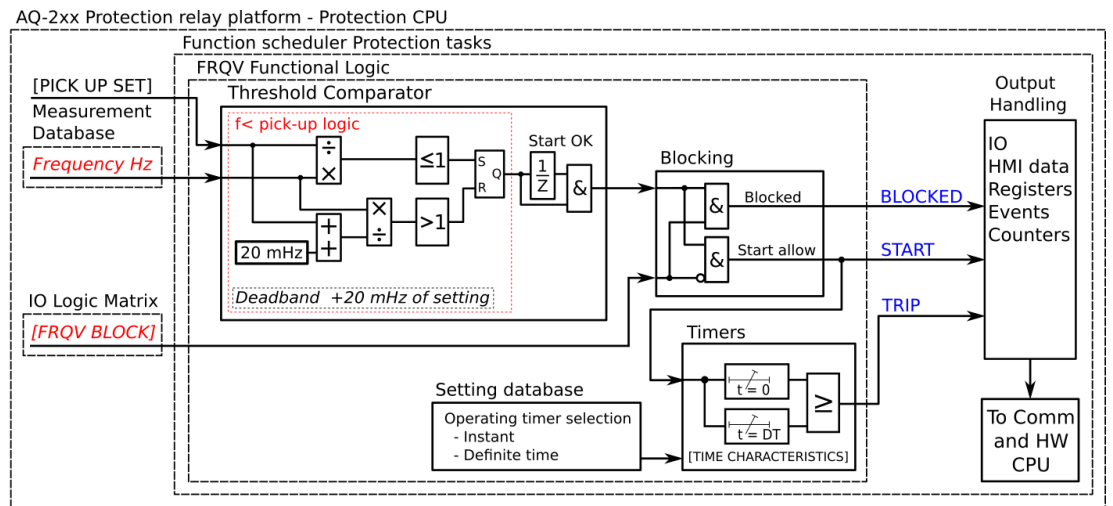

Figure. 4.4.8 - 54. Simplified function block diagram of the  $f <$  function.



## Measured input

The frequency protection function compares the measured frequency to the pick-up setting (given in Hz). There are three (3) frequency references available. Please refer to "[Frequency tracking and scaling](#)" chapter for a detailed description of frequency tracking.

Table. 4.4.8 - 76. Measurement inputs of the  $f >/<$  function.

Signals	Description
Frequency reference 1	Primary frequency reference
Frequency reference 2	Secondary frequency reference
Frequency reference 3	Tertiary frequency reference

## General settings

The following general settings define the general behavior of the function. These settings are static i.e. it is not possible to change them by editing the setting group.

Table. 4.4.8 - 77. General settings of the function.

Name	Range	Default	Description
f</> LN mode	<ul style="list-style-type: none"> <li>On</li> <li>Blocked</li> <li>Test</li> <li>Test/Blocked</li> <li>Off</li> </ul>	On	Set mode of FRQV block. This parameter is visible only when <i>Allow setting of individual LN mode</i> is enabled in <i>General</i> menu.
f> enable f>> enable f>>> enable f>>>> enable f< enable f<< enable f<<< enable f<<<< enable	<ul style="list-style-type: none"> <li>No</li> <li>Yes</li> </ul>	No	Enables or disables the stage.
f> force status to f>> force status to f>>> force status to f>>>> force status to f< force status to f<< force status to f<<< force status to f<<<< force status to	<ul style="list-style-type: none"> <li>Normal</li> <li>Start</li> <li>Trip</li> <li>Blocked</li> </ul>	Normal	Force the status of the function. Visible only when <i>Enable stage forcing</i> parameter is enabled in <i>General</i> menu.

### Pick-up settings

The  $f_{set>}$ ,  $f_{set>>}$ , etc. setting parameters control the pick-up of each stage of the f>/< function. They define the maximum or minimum allowed measured frequency before action from the function. The function constantly calculates the ratio between the pick-up setting and the measured frequency. The reset ratio of 20mHz is built into the function and is always relative to the pick-up value.

Setting group selection controls the operating characteristics of the function, i.e. the user or user-defined logic can change function parameters while the function is running.

Table. 4.4.8 - 78. Pick-up settings.

Name	Range	Step	Default	Description
f> used in setting group	<ul style="list-style-type: none"> <li>No</li> <li>Yes</li> </ul>	-	No	Enables or disables the protection stage in the setting group.
fset>	10.00...80.00Hz	0.01Hz	51Hz	Pick-up setting
fset<	5.00...75.00Hz	0.01Hz	49Hz	Pick-up setting

Name	Range	Step	Default	Description
f< undervoltage block	0.00...120.00%Un	0.01%Un	0.00%Un	Block setting. If set to zero, blocking is not in use. When the measured voltage drops below the set value, the operation of the functions is blocked.

## Operating time characteristics for trip and reset

This function supports definite time delay (DT). For detailed information on these delay types please refer to the chapter "[General properties of a protection function](#)" and its section "[Operating time characteristics](#)".

## Read-only parameters

The function's *Info* page displays useful, real-time information on the state of the protection function. It is accessed either through the device's HMI display, or through the setting tool software when it is connected to the device and its Live Edit mode is active.

Table. 4.4.8 - 79. Information displayed by the function.

Name	Range	Step	Description
f</> LN behaviour	<ul style="list-style-type: none"> <li>On</li> <li>Blocked</li> <li>Test</li> <li>Test/Blocked</li> <li>Off</li> </ul>	-	Displays the mode of FRQV block. This parameter is visible only when <i>Allow setting of individual LN mode</i> is enabled in <i>General</i> menu.
f</> condition	<ul style="list-style-type: none"> <li>Normal</li> <li>Start</li> <li>Trip</li> <li>Blocked</li> </ul>	-	Displays the status of the protection function.
f meas / f set	0.000...20.000f <sub>m</sub> /f <sub>set</sub>	0.001f <sub>m</sub> /f <sub>set</sub>	The ratio between the measured frequency and the pick-up value.
Expected operating time	0.000...1800.000s	0.005s	Displays the expected operating time when a fault occurs.
Time remaining to trip	-1800.000...1800.000s	0.005s	When the function has detected a fault and counts down time towards a trip, this displays how much time is left before tripping occurs.

## Function blocking

The blocking signal is evaluated at the start of each program cycle. The blocking signals are connected to the function's dedicated input, which can be configured in the *IO* → *Blocking Input Control* tab of the function.

- When the pick-up element activates and the blocking signal is not active, a START signal is generated, and the function starts or continues with the trip time countdown.
- When the pick-up element activates and the blocking signal is active, a BLOCKED signal is generated, and the function does not process the event further.
- When a START signal is already active and the blocking input signal becomes active, the START signal is reset and BLOCKED signal is generated. The release time characteristics are then processed in the same way as when the pick-up signal is reset.

The blocking signal needs to reach the device minimum of 5 ms before the set operating delay has passed in order for the blocking to activate in time.

## Events and registers

The frequency function (abbreviated "FRQV" in event block names) generates events and registers from the status changes in the events listed below. The user can select which event messages are stored in the main event buffer: ON, OFF, or both. The events triggered by the function are recorded with a time stamp.

The function's outputs can be used for direct I/O controlling and user logic programming. The function also provides a resettable cumulative counter for the START, TRIP and BLOCKED events.

Table. 4.4.8 - 80. Event messages.

Event block name	Event names
FRQV1	f>/< Start ON/OFF
FRQV1	f>/< Trip ON/OFF
FRQV1	f>/< Blocked ON/OFF

The function registers its operation into the last twelve (12) time-stamped registers. The table below presents the structure of the function's register content.

Table. 4.4.8 - 81. Register content.

Register	Description
Date and time	dd.mm.yyyy hh:mm:ss.mss
Event	Event name
f Pre-trig (Hz)	Start/Trip -20ms frequency
f Fault (Hz)	Fault frequency
Setting group in use	Setting group 1...8 active

### 4.4.9 Rate-of-change of frequency (df/dt>/<; 81R)

The rate-of-change of frequency function is used to detect fast drops or increases in frequency. If the load changes fast this function detects and clears the frequency-based faults faster than conventional underfrequency and overfrequency protections. One of the most common causes for the frequency to deviate from its nominal value is an unbalance between the generated power and the load demand. If the unbalance is big the frequency changes rapidly.

The rate-of-change of frequency protection can also be applied to detect a loss of mains situation. Loss of mains is a situation where a part of the network (incorporating generation) loses its connection with the rest of the system (i.e. becomes an islanded network). A generator that is not disconnected from the network can cause safety hazards. A generator can also be automatically reconnected to the network, which can cause damage to the generator and the network.

Figure. 4.4.9 - 55. Operation of the  $df/dt > / <$  function when the frequency starts but doesn't trip.

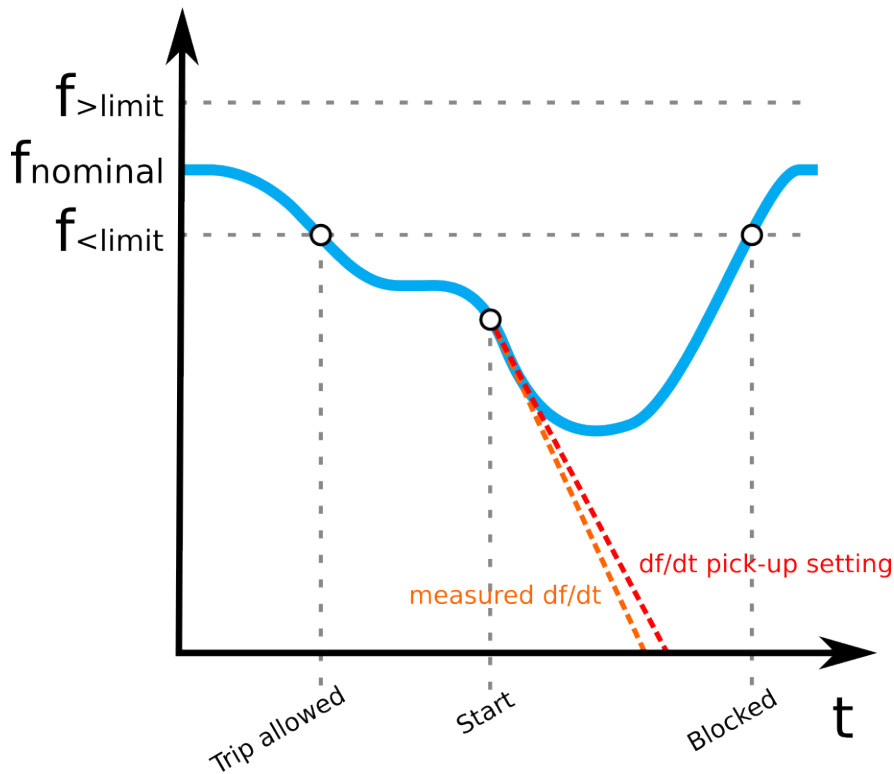

The figure above presents an example of the  $df/dt > / <$  function's operation when the frequency is decreasing. If the  $f_{<limit}$  and/or  $f_{>limit}$  is activated, the function does not trip no matter how fast the measured frequency changes if it's over the  $f_{<limit}$  or under  $f_{>limit}$ . As can be seen in the figure above, when the frequency decreases under the  $f_{<limit}$ , tripping is allowed although the change of frequency is not yet fast enough for the function to trip. Later the frequency makes a fast dip and as a result the change of frequency is faster than the set pick-up value which then causes the function to operate.

Each stage can be activated and deactivated individually. After the  $f > / <$  mode has been activated (*Protection → Stage activation → Frequency stages*), the user can activate and deactivate the individual stages at will (*Protection → Frequency → Frequency protection  $f > / <$  → INFO → Stage operational setup*).

Figure. 4.4.9 - 56. Simplified function block diagram of the  $df/dt > / <$  function.

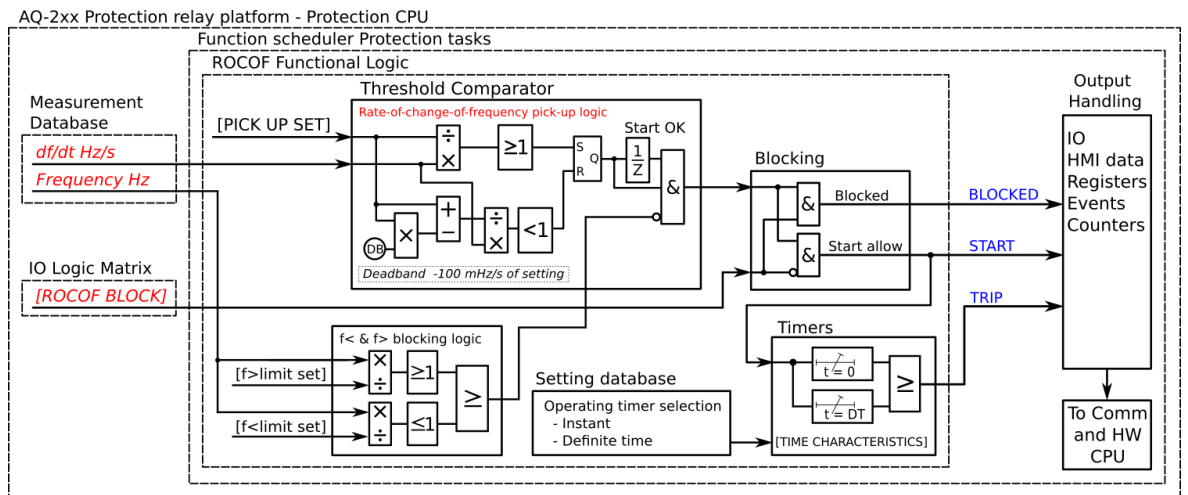

## Measured input

The rate-of-change of frequency protection function compares the measured  $df/dt$  ratio to the pick-up setting (given in Hz/s). There are three (3) frequency references available. Please refer to "[Frequency tracking and scaling](#)" chapter for a detailed description of frequency tracking.

Table. 4.4.9 - 82. Measurement inputs of the  $df/dt$  function.

Signals	Description
Frequency reference 1	Primary frequency reference
Frequency reference 2	Secondary frequency reference
Frequency reference 3	Tertiary frequency reference

## General settings

The following general settings define the general behavior of the function. These settings are static i.e. it is not possible to change them by editing the setting group.

Table. 4.4.9 - 83. General settings of the function.

Name	Range	Step	Default	Description
$df/dt$ LN mode	<ul style="list-style-type: none"> <li>On</li> <li>Blocked</li> <li>Test</li> <li>Test/Blocked</li> <li>Off</li> </ul>	-	On	Set mode of DFT block. This parameter is visible only when <i>Allow setting of individual LN mode</i> is enabled in <i>General</i> menu.
Max allowed $df/dt$ rate	0.10...50.00 Hz/s	0.10 Hz/s	20 Hz/s	If $df/dt$ rate exceeds this setting, the function is blocked.
$df/dt$ enable	<ul style="list-style-type: none"> <li>No</li> <li>Yes</li> </ul>	-	No	Enables or disables the stage.
$df/dt$ force status to	<ul style="list-style-type: none"> <li>Normal</li> <li>Start</li> <li>Trip</li> <li>Blocked</li> </ul>	-	Normal	Force the status of the function. Visible only when <i>Enable stage forcing</i> parameter is enabled in <i>General</i> menu.

## Pick-up and time delay

The  $df/dt$  (1) pick-up,  $df/dt$  (2) pick-up, etc. setting parameters control the pick-up of each stage of the  $df/dt$  function. They define the maximum or minimum allowed change of frequency before action from the function. The function constantly calculates the ratio between the pick-up setting and the measured  $df/dt$ . The reset ratio of  $\pm 100$  mHz/s is built into the function and is always relative to the pick-up value. The  $f$  limit value is used to block the function from operating near the nominal frequency.

Setting group selection controls the operating characteristics of the function, i.e. the user or user-defined logic can change function parameters while the function is running.

Table. 4.4.9 - 84. Pick-up settings.

Name	Range	Step	Default	Description
df/dt>/< (1...8) used in setting group	<ul style="list-style-type: none"> <li>No</li> <li>Yes</li> </ul>	-	No	Enables the protection stage in setting group.
df/dt>/< (1...8) operating mode	<ul style="list-style-type: none"> <li>Rising</li> <li>Falling</li> <li>Both</li> </ul>	-	Rising	Defines the operation mode of the protection stage. In "Rising" mode df/dt function can trip only from increasing frequency. In "Falling" mode df/dt function can trip only from decreasing frequency. "Both" allows df/dt to trip from both.
df/dt>/< (1...8) frequency limit	<ul style="list-style-type: none"> <li>Not used</li> <li>Use f limit</li> </ul>	-	Not used	Displays if frequency limits are used or not.
df/dt>/< (1...8) pick-up	0.01...10.00Hz/s	0.01Hz/s	0.2Hz/s	Pick-up setting.
df/dt>/< (1...8) f< limit	7.00...65.00Hz	0.01Hz	49.95Hz	Underfrequency limit. Tripping is permitted when measured frequency is under this value. This parameter is visible only when operation mode is set to "Falling" or "Both".
df/dt>/< (1...8) f> limit	10.00...70.00Hz	0.01Hz	51Hz	Overfrequency limit. Tripping is permitted if measured frequency is above this value. This parameter is visible only when operation mode is set to "Rising" or "Both".

### Operating time characteristics for trip and reset

This function supports definite time delay (DT). For detailed information on these delay types please refer to the chapter "[General properties of a protection function](#)" and its section "[Operating time characteristics](#)".

### Read-only parameters

The function's *Info* page displays useful, real-time information on the state of the protection function. It is accessed either through the device's HMI display, or through the setting tool software when it is connected to the device and its Live Edit mode is active.

Table. 4.4.9 - 85. Information displayed by the function.

Name	Range	Step	Description
df/dt >/< LN behaviour	<ul style="list-style-type: none"> <li>On</li> <li>Blocked</li> <li>Test</li> <li>Test/Blocked</li> <li>Off</li> </ul>	-	Displays the mode of DFT block. This parameter is visible only when <i>Allow setting of individual LN mode</i> is enabled in <i>General</i> menu.
Measured df/ dt	0.000...20.000Hz/s	0.001Hz/s	Rate-of-change-of-frequency at the moment.

Name	Range	Step	Description
df/dt >/< (1...8) condition	<ul style="list-style-type: none"> <li>• Normal</li> <li>• Start</li> <li>• Trip</li> <li>• Blocked</li> </ul>	-	Displays the status of the protection function.
df/dt >/< (1...8) df/dt meas / df/dt set	0.000...20.000p.u.	0.005p.u.	The ratio between the rate-of-change-of-frequency and the pick-up value.
Expected operating time	0.000...1800.000s	0.005s	Displays the expected operating time when a fault occurs.
Time remaining to trip	-1800.000...1800.000s	0.005s	When the function has detected a fault and counts down time towards a trip, this displays how much time is left before tripping occurs.

## Function blocking

The blocking signal is evaluated at the start of each program cycle. The blocking signals are connected to the function's dedicated input, which can be configured in the *IO* → *Blocking Input Control* tab of the function.

- When the pick-up element activates and the blocking signal is not active, a START signal is generated, and the function starts or continues with the trip time countdown.
- When the pick-up element activates and the blocking signal is active, a BLOCKED signal is generated, and the function does not process the event further.
- When a START signal is already active and the blocking input signal becomes active, the START signal is reset and BLOCKED signal is generated. The release time characteristics are then processed in the same way as when the pick-up signal is reset.

The blocking signal needs to reach the device minimum of 5 ms before the set operating delay has passed in order for the blocking to activate in time.

## Events and registers

The rate-of-change of frequency function (abbreviated "DFT" in event block names) generates events and registers from the status changes in the events listed below. The user can select which event messages are stored in the main event buffer: ON, OFF, or both. The events triggered by the function are recorded with a time stamp.

The function's outputs are can be used for direct I/O controlling and user logic programming. The function also provides a resettable cumulative counter for the START, TRIP and BLOCKED events.

Table. 4.4.9 - 86. Event messages.

Event block name	Event names
DFT1	df/dt>/< (1...8) Start ON/OFF
DFT1	df/dt>/< (1...8) Trip ON/OFF
DFT1	df/dt>/< (1...8) Blocked ON/OFF

The function registers its operation into the last twelve (12) time-stamped registers. The table below presents the structure of the function's register content.

Table. 4.4.9 - 87. Register content.

Register	Description
Date and time	dd.mm.yyyy hh:mm:ss.mss
Event	Event name
df/dt>/< Pre-trig (Hz/s)	Start/Trip –20ms df/dt>/<
f Pre-trig (Hz)	Start/Trip –20ms frequency
df/dt>/< Fault (Hz/s)	Fault df/dt>/<
f Fault (Hz)	Fault frequency
Setting group in use	Setting group 1...8 active

### 4.4.10 Resistance temperature detectors (RTD)

Resistance temperature detectors (or RTDs) can be used to measure both temperatures of motors/generators and ambient temperatures. Typically an RTD is a thermocouple or of type PT100. Up to three (3) separate RTD modules based on an external Modbus are supported; each can hold up to eight (8) measurement elements. Up to two (2) separate RTD option cards are supported by this function. Sixteen (16) individual element monitors can be set for this alarm function, and each of those can be set to alarm two (2) separate alarms from one selected input. The user can set alarms and measurements to be either in degrees Celsius or Fahrenheit.

Figure. 4.4.10 - 57. Simplified function block diagram of the resistance temperature detection function.

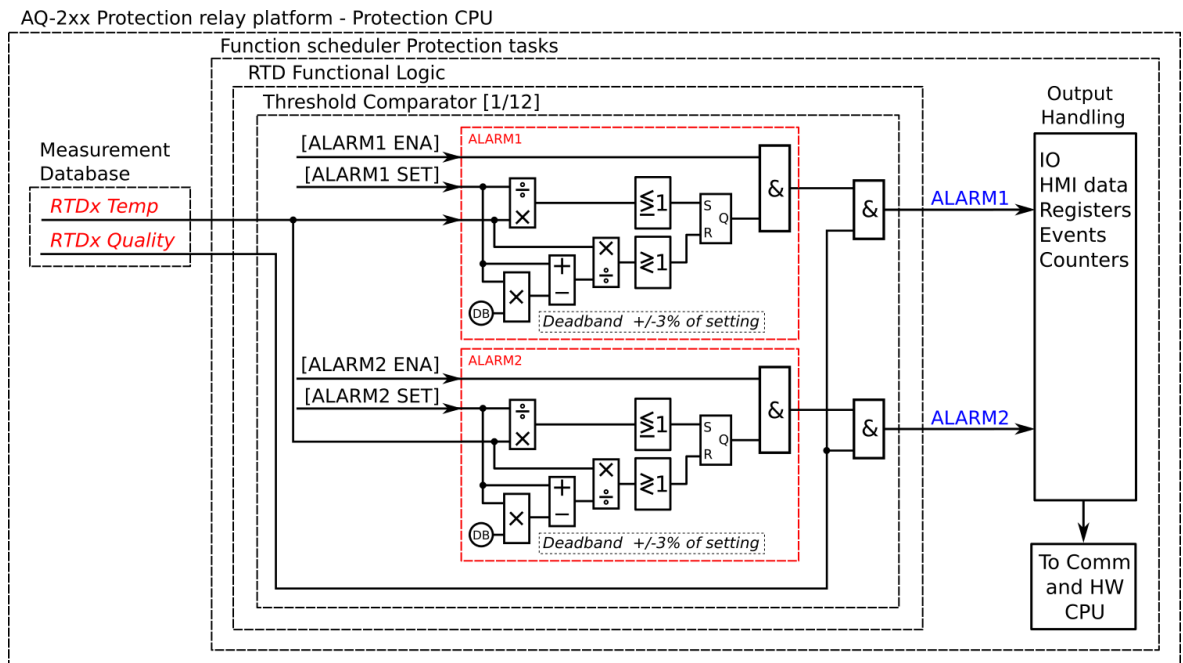

## Settings

Table. 4.4.10 - 88. General settings of the function.

Name	Range	Default	Description
RTD LN mode	<ul style="list-style-type: none"> <li>On</li> <li>Blocked</li> <li>Test</li> <li>Test/Blocked</li> <li>Off</li> </ul>	On	Set mode of RTD block. This parameter is visible only when <i>Allow setting of individual LN mode</i> is enabled in <i>General</i> menu.
RTD LN behaviour	<ul style="list-style-type: none"> <li>On</li> <li>Blocked</li> <li>Test</li> <li>Test/Blocked</li> <li>Off</li> </ul>	-	Displays the mode of RTD block. This parameter is visible only when <i>Allow setting of individual LN mode</i> is enabled in <i>General</i> menu.

Setting up an RTD measurement, the user first needs to set the measurement module to scan the wanted RTD elements. A multitude of Modbus-based modules are supported. Communication requires bitrate, databits, parity, stopbits and Modbus I/O protocol to be set; this is done at *Communication* → *Connections*. Once communication is set, the wanted channels are selected at *Communication* → *Protocols* → *Modbus I/O*. Then the user selects the measurement module from the three (3) available modules (A, B and C), as well as the poll address. Additionally, both the module type and the polled channels need to be set. When using a thermocouple module, the thermo element type also needs to be set for each of the measurement channels. Once these settings are done the RTDs are ready for other functions.

Table. 4.4.10 - 89. Function settings for Channel x (Sx).

Name	Range	Step	Default	Description
S1...S16 enable	No Yes	-	No	Enables/disables the selection of sensor measurements and alarms.
S1...S16 module	<ul style="list-style-type: none"> <li>InternalRTD1</li> <li>InternalRTD2</li> <li>ExtModuleA</li> <li>ExtModuleB</li> <li>ExtModuleC</li> </ul>	-	InternalRTD1	Selects the measurement module. Internal RTD modules are option cards installed to the device. External modules are Modbus based external devices.
S1...S16 channel	<ul style="list-style-type: none"> <li>Channel 0</li> <li>Channel 1</li> <li>Channel 2</li> <li>Channel 3</li> <li>Channel 4</li> <li>Channel 5</li> <li>Channel 6</li> <li>Channel 7</li> </ul>	-	Channel 0	Selects the measurement channel in the selected module.
S1...S16 Deg C/Dec F	<ul style="list-style-type: none"> <li>Deg C</li> <li>Deg F</li> </ul>	-	Deg C	Selects the measurement temperature scale (Celsius or Fahrenheit).
S1...S16 Measurement	-	-	-	Displays the measurement value in the selected temperature scale.

Name	Range	Step	Default	Description
S1...S16 Sensor	<ul style="list-style-type: none"> <li>Ok</li> <li>Invalid</li> </ul>	-	-	Displays the measured sensor's data validity. If the sensor reading has any problems, the sensor data is set to "Invalid" and the alarms are not activated.
S1...S16 Enable alarm 1	<ul style="list-style-type: none"> <li>Disable</li> <li>Enable</li> </ul>	-	Disable	Enables/disables the selection of Alarm 1 for the measurement channel x.
S1...S16 Alarm1 >/<	<ul style="list-style-type: none"> <li>&gt;</li> <li>&lt;</li> </ul>	-	>	Selects whether the alarm activates when measurement is above or below the pick-up setting value.
S1...S16 Alarm1	-101.0...2000.0deg	0.1deg	0.0deg	Sets the pick-up value for Alarm 1. The alarm is activated if the measurement goes above or below this setting mode (depends on the selected mode in "Sx Alarm1 >/<").
S1...S16 sensor	<ul style="list-style-type: none"> <li>Ok</li> <li>Invalid</li> </ul>	-	-	Displays the measured sensor's data validity. If the sensor reading has any problems, the sensor data is set to "Invalid" and the alarms are not activated.
S1...S16 Enable alarm 2	<ul style="list-style-type: none"> <li>Disable</li> <li>Enable</li> </ul>	-	Disable	Enables/disables the selection of Alarm 2 for the measurement channel x.
S1...S16 Alarm2 >/<	<ul style="list-style-type: none"> <li>&gt;</li> <li>&lt;</li> </ul>	-	>	Selects whether the measurement is above or below the setting value.
S1...S16 Alarm2	-101.0...2000.0deg	0.1deg	0.0deg	Sets the value for Alarm 2. The alarm is activated if the measurement goes above or below this setting mode (depends on the selected mode in "Sx Alarm2 >/<").

Function can be set to monitor the measurement data from previously set RTD channels. A single channel can be set to have several alarms if the user sets the channel to multiple sensor inputs. In each sensor setting the user can select the monitored module and channel, as well as the monitoring and alarm setting units (°C or °F). The alarms can be enabled, given a setting value (in degrees), and be set to trigger either above or below the setting value. There are sixteen (16) available sensor inputs in the function. An active alarm requires a valid channel measurement. It can be invalid if communication is not working or if a sensor is broken.

When the RTDs have been set, the values can be read to SCADA (or some other control system). The alarms can also be used for direct output control as well as in logics.

## Events

The resistance temperature detector function (abbreviated "RTD" in event block names) generates events and registers from the status changes in the events listed below. The user can select which event messages are stored in the main event buffer: ON, OFF, or both. The events triggered by the function are recorded with a time stamp.

The function's outputs can be used for direct I/O controlling and user logic programming. The function also provides a resettable cumulative counter for the ALARM events.

The function offers sixteen (16) independent stages; the events are segregated for each stage operation.

Table. 4.4.10 - 90. Event messages.

Event block name	Event names
RTD1	S1...S16 Alarm1 ON/OFF
RTD1	S1...S16 Alarm2 ON/OFF
RTD1	S1...S16 Meas Ok/Invalid

### 4.4.11 Programmable stage (PSx>/<; 99)

The programmable stage is a stage that the user can program to create more advanced applications, either as an individual stage or together with programmable logic. The device has ten programmable stages, and each can be set to follow one to three analog measurements. The programmable stages have three available pick up terms options: overX, underX and rate-of-change of the selected signal. Each stage includes a definite time delay to trip after a pick-up has been triggered.

The programmable stage cycle time is 5 ms. The pick-up delay depends on which analog signal is used as well as its refresh rate (typically under a cycle in a 50 Hz system).

The number of programmable stages to be used is set in the *INFO* tab. When this function has been set as "Activated", the number of programmable stages can be set anywhere between one (1) and ten (10) depending on how many the application needs. In the image below, the number of programmable stages have been set to two which makes PS1 and PS2 to appear. Inactive stages are hidden until they are activated.

Please note that setting the number of available stages does not activate those stages, as they also need to be enabled individually with the *PSx >/< Enabled* parameter. When enabled an active stage shows its current state (condition), the expected operating time and the time remaining to trip under the activation parameters. If a stage is not active the *PSx >/< condition* parameter will merely display "Disabled".

Setting group selection controls the operating characteristics of the function, i.e. the user or user-defined logic can change function parameters while the function is running.

#### General settings

The following general settings define the general behavior of the function. These settings are static i.e. it is not possible to change them by editing the setting group.

Table. 4.4.11 - 91. General settings of the function.

Name	Range	Description
PSx >/< LN mode	<ul style="list-style-type: none"> <li>• On</li> <li>• Blocked</li> <li>• Test</li> <li>• Test/ Blocked</li> <li>• Off</li> </ul>	Set mode of PSx block. This parameter is visible only when <i>Allow setting of individual LN mode</i> is enabled in <i>General</i> menu.

Name	Range	Description
PSx >/< LN behaviour	<ul style="list-style-type: none"> <li>• On</li> <li>• Blocked</li> <li>• Test</li> <li>• Test/ Blocked</li> <li>• Off</li> </ul>	<p>Displays the mode of PSx block.</p> <p>This parameter is visible only when <i>Allow setting of individual LN mode</i> is enabled in <i>General</i> menu.</p>
PSx >/< Available stages	1...10	Defines the available amount of stages.
PSx >/< Enabled	<ul style="list-style-type: none"> <li>• Disabled</li> <li>• Enabled</li> </ul>	Enables the stage.
PSx >/< Force status to	<ul style="list-style-type: none"> <li>• Normal</li> <li>• Start</li> <li>• Trip</li> <li>• Blocked</li> </ul>	Force the status of the function. Visible only when <i>Enable stage forcing</i> parameter is enabled in <i>General</i> menu.
PSx >/< Measurement setting	<ul style="list-style-type: none"> <li>• One magnitude comp</li> <li>• Two magnitude comp</li> <li>• Three magnitude comp</li> </ul>	Defines how many measurement magnitudes are used by the stage.
PSx >/< Magnitude handling ("Two magnitude comp" selected)	Mag1 x Mag2	Multiplies Signal 1 by Signal 2. The comparison uses the product of this calculation.
	Mag1 / Mag2	Divides Signal 1 by Signal 2. The comparison uses the product of this calculation.
	Max (Mag1, Mag2)	The bigger value of the chosen signals is used in the comparison.
	Min (Mag1, Mag2)	The smaller value of the chosen signals is used in the comparison.
	Mag1 OR Mag2	Either of the chosen signals has to fulfill the pick-up condition. Both signals have their own pick-up setting.
	Mag1 AND Mag2	Both of the chosen signals have to fulfill the pick-up condition. Both signals have their own pick-up setting.
	Mag1 – Mag2	Subtracts Signal 2 from Signal 1. The comparison uses the product of this calculation.
PSx >/< Magnitude handling ("Three magnitude comp" selected)	Mag1 x Mag2 x Mag3	Multiplies Signals 1, 2 and 3. The comparison uses the product of this calculation.
	Max (Mag1, Mag2, Mag3);	The biggest value of the chosen signals is used in the comparison.
	Min (Mag1, Mag2, Mag3)	The smallest value of the chosen signals is used in the comparison.
	Mag1 OR Mag2 OR Mag3	Any of the signals fulfills the pick-up condition. Each signal has their own pick-up setting.

Name	Range	Description
	Mag1 AND Mag2 AND Mag3	All of the signals need to fulfill the pick-up condition. Each signal has their own pick-up setting.
	(Mag1 OR Mag2) AND Mag3	Signals 1 OR 2 AND 3 need to fulfill the pick-up condition. Each signal has their own pick-up setting.
PSx Magnitude selection	<ul style="list-style-type: none"> <li>• Currents</li> <li>• Voltages</li> <li>• Powers</li> <li>• Impedances and admittances</li> <li>• Others</li> </ul>	Defines the measurement type used by the stage
PSx MagnitudeX	See table below.	Defines the measurement used by the stage. Available parameters depend on selected measurement type.
PSx MagnitudeX multiplier	-5 000 000...5 000 000	Multiplies the selected measurement. 1 by default (no multiplication). See section "Magnitude multiplier" for more information.

## Analog values

The numerous analog signals have been divided into categories to help the user find the desired value.

Table. 4.4.11 - 92. Phase and residual current measurements (IL1, IL2, IL3, Io1 and Io2)

Name	Description
ILx ff (p.u.)	Fundamental frequency RMS value (in p.u.)
ILx 2 <sup>nd</sup> h.	ILx 2 <sup>nd</sup> harmonic value (in p.u.)
ILx 3 <sup>rd</sup> h.	ILx 3 <sup>rd</sup> harmonic value (in p.u.)
ILx 4 <sup>th</sup> h.	ILx 4 <sup>th</sup> harmonic value (in p.u.)
ILx 5 <sup>th</sup> h.	ILx 5 <sup>th</sup> harmonic value (in p.u.)
ILx 7 <sup>th</sup> h.	ILx 7 <sup>th</sup> harmonic value (in p.u.)
ILx 9 <sup>th</sup> h.	ILx 9 <sup>th</sup> harmonic value (in p.u.)
ILx 11 <sup>th</sup> h.	ILx 11 <sup>th</sup> harmonic value (in p.u.)
ILx 13 <sup>th</sup> h.	ILx 13 <sup>th</sup> harmonic value (in p.u.)
ILx 15 <sup>th</sup> h.	ILx 15 <sup>th</sup> harmonic value (in p.u.)
ILx 17 <sup>th</sup> h.	ILx 17 <sup>th</sup> harmonic value (in p.u.)
ILx 19 <sup>th</sup> h.	ILx 19 <sup>th</sup> harmonic value (in p.u.)
ILx TRMS	ILx TRMS value (in p.u.)

Name	Description
ILx Ang	ILx Angle (degrees)

Table. 4.4.11 - 93. Other current measurements

Name	Description
I0Z Mag	Zero sequence current value (in p.u.)
I0CALC Mag	Calculated I0 value (in p.u.)
I1 Mag	Positive sequence current value (in p.u.)
I2 Mag	Negative sequence current value (in p.u.)
I0CALC Ang	Angle of calculated residual current (degrees)
I1 Ang	Angle of positive sequence current (degrees)
I2 Ang	Angle of negative sequence current (degrees)
I01ResP	I01 primary current of a current-resistive component
I01CapP	I01 primary current of a current-capacitive component
I01ResS	I01 secondary current of a current-resistive component
I01CapS	I01 secondary current of a current-capacitive component
I02ResP	I02 primary current of a current-resistive component
I02CapP	I02 primary current of a current-capacitive component
I02ResS	I02 secondary current of a current-resistive component
I02CapS	I02 secondary current of a current-capacitive component

Table. 4.4.11 - 94. Voltage measurements

Name	Description
UL12Mag	UL12 Primary voltage V
UL23Mag	UL23 Primary voltage V
UL31Mag	UL31 Primary voltage V
UL1Mag	UL1 Primary voltage V
UL2Mag	UL2 Primary voltage V
UL3Mag	UL3 Primary voltage V
UL12Ang	UL12 angle (degrees)
UL23Ang	UL23 angle (degrees)
UL31Ang	UL31 angle (degrees)

Name	Description
UL1Ang	UL1 angle (degrees)
UL2Ang	UL2 angle (degrees)
UL3Ang	UL3 angle (degrees)
U0Ang	UL0 angle (degrees)
U0CalcMag	Calculated residual voltage
U1 pos.seq.V Mag	Positive sequence voltage
U2 neg.seq.V Mag	Negative sequence voltage
U0CalcAng	Calculated residual voltage angle (degrees)
U1 pos.seq.V Ang	Positive sequence voltage angle (degrees)
U2 neg.seq.V Ang	Negative sequence voltage angle (degrees)
U3SMag	U3 channel voltage magnitude when the channel is set to "SS" mode
U3SAng	U3 channel voltage angle when the channel is set to "SS" mode
U4SMag	U4 channel voltage magnitude when the channel is set to "SS" mode
U4SAng	U4 channel voltage angle when the channel is set to "SS" mode
T1 Tap U	Voltage measured by the AVR function in the T1 device (in parallel tap changer mode)
T2 Tap U	Voltage measured by the AVR function in the T2 device (in parallel tap changer mode)
T3 Tap U	Voltage measured by the AVR function in the T3 device (in parallel tap changer mode)
T4 Tap U	Voltage measured by the AVR function in the T4 device (in parallel tap changer mode)

Table. 4.4.11 - 95. Power measurements

Name	Description
S3PH	Three-phase apparent power S (kVA)
P3PH	Three-phase active power P (kW)
Q3PH	Three-phase reactive power Q (kvar)
tanfi3PH	Three-phase active power direction
cosfi3PH	Three-phase reactive power direction
SLx	Phase apparent power L1 / L2 / L3 S (kVA)
PLx	Phase active power L1 / L2 / L3 P (kW)
QLx	Phase reactive power L1 / L2 / L3 Q (kVar)
tanfiLx	Phase active power direction L1 / L2 / L3
cosfiLx	Phase reactive power direction L1 / L2 / L3

Name	Description
PoFaLx	Phase power factor L1 / L2 / L3
PoFa3PH	Three-phase power factor

Table. 4.4.11 - 96. Phase-to-phase and phase-to-neutral impedances, resistances and reactances

Name	Description
RLxPri	Resistance R L12, L23, L31, L1, L2, L3 primary ( $\Omega$ )
XLxPri	Reactance X L12, L23, L31, L1, L2, L3 primary ( $\Omega$ )
ZLxPri	Impedance Z L12, L23, L31, L1, L2, L3 primary ( $\Omega$ )
RLxSec	Resistance R L12, L23, L31, L1, L2, L3 secondary ( $\Omega$ )
XLxSec	Reactance X L12, L23, L31, L1, L2, L3 secondary ( $\Omega$ )
ZLxSec	Impedance Z L12, L23, L31, L1, L2, L3 secondary ( $\Omega$ )
ZLxAngle	Impedance Z L12, L23, L31, L1, L2, L3 angle

Table. 4.4.11 - 97. Other impedances, resistances and reactances

Name	Description
RSeqPri	Positive Resistance R primary ( $\Omega$ )
XSeqPri	Positive Reactance X primary ( $\Omega$ )
RSeqSec	Positive Resistance R secondary ( $\Omega$ )
XSeqSec	Positive Reactance X secondary ( $\Omega$ )
ZSeqPri	Positive Impedance Z primary ( $\Omega$ )
ZSeqSec	Positive Impedance Z secondary ( $\Omega$ )
ZSeqAngle	Positive Impedance Z angle

Table. 4.4.11 - 98. Conductances, susceptances and admittances (L1, L2, L3)

Name	Description
GLxPri	Conductance G L1, L2, L3 primary (mS)
BLxPri	Susceptance B L1, L2, L3 primary (mS)
YLxPriMag	Admittance Y L1, L2, L3 primary (mS)
GLxSec	Conductance G L1, L2, L3 secondary (mS)
BLxSec	Susceptance B L1, L2, L3 secondary (mS)
YLxSecMag	Admittance Y L1, L2, L3 secondary (mS)

Name	Description
YLxAngle	Admittance Y L1, L2, L3 angle (degrees)

Table. 4.4.11 - 99. Other conductances, susceptances and admittances

Name	Description
G0Pri	Conductance G0 primary (mS)
B0Pri	Susceptance B0 primary (mS)
G0Sec	Conductance G0 secondary (mS)
B0Sec	Susceptance B0 secondary (mS)
Y0Pri	Admittance Y0 primary (mS)
Y0Sec	Admittance Y0 secondary (mS)
Y0Angle	Admittance Y0 angle

Table. 4.4.11 - 100. Other measurements

Name	Description
System f.	System frequency
Ref f1	Reference frequency 1
Ref f2	Reference frequency 2
M Thermal T	Motor thermal temperature
F Thermal T	Feeder thermal temperature
T Thermal T	Transformer thermal temperature
RTD meas 1...16	RTD measurement channels 1...16
Ext RTD meas 1...8	External RTD measurement channels 1...8 (ADAM)
mA input 7,8,15,16	mA input channels 7, 8, 15, 16
ASC 1...4	Analog scaled curves 1...4
mAln1...4 (Tcard1/2)	mA input channels in T option card(s)

### Magnitude multiplier

Programmable stages can be set to follow one, two or three analog measurements with the *PSx >/< Measurement setting* parameter. The user must choose a measurement signal value to be compared to the set value, and possibly also set a scaling for the signal. The image below is an example of scaling: a primary zero sequence voltage has been scaled to a percentage value for easier handling when setting up the comparator.

The scaling factor was calculated by taking the inverse value of a 20 kV system:

$$k = \frac{1}{20\,000 \text{ V} / \sqrt{3}} = 0.008\,66$$

When this multiplier is in use, the full earth fault zero sequence voltage is 11 547 V primary which is then multiplied with the above-calculated scaling factor, inverting the final result to 100%. This way a pre-processed signal is easier to set, although it is also possible to just use the scaling factor of 1.0 and set the desired pick-up limit as the primary voltage. Similarly, any chosen measurement value can be scaled to the desired form.

### Read-only parameters

The function's *Info* page displays useful, real-time information on the state of the protection function. It is accessed either through the device's HMI display, or through the setting tool software when it is connected to the device and its Live Edit mode is active.

Table. 4.4.11 - 101. Information displayed by the function.

Name	Range	Description
PSx >/< LN behaviour	<ul style="list-style-type: none"> <li>• On</li> <li>• Blocked</li> <li>• Test</li> <li>• Test/Blocked</li> <li>• Off</li> </ul>	Displays the mode of PSx block. This parameter is visible only when <i>Allow setting of individual LN mode</i> is enabled in <i>General</i> menu.
Condition	<ul style="list-style-type: none"> <li>• Normal</li> <li>• Start</li> <li>• Trip</li> <li>• Blocked</li> </ul>	Displays status of the function.
Expected operating time	-1800.000...1800.000s	Displays the expected operating time when a fault occurs.
Time remaining to trip	0.000...1800.000s	When the function has detected a fault and counts down time towards a trip, this displays how much time is left before tripping occurs.
PSx Scaled magnitude X	-5 000 000...5 000 000	Displays measurement value after multiplying it the value set to <i>PSx Magnitude multiplier</i> .
PSx >/< MeasMag1/ MagSet1 at the moment	-5 000 000...5 000 000	The ratio between measured magnitude and the pick-up setting.
PSx >/< MeasMag2/ MagSet2 at the moment	-5 000 000...5 000 000	The ratio between measured magnitude and the pick-up setting.
PSx >/< MeasMag3/ MagSet3 at the moment	-5 000 000...5 000 000	The ratio between measured magnitude and the pick-up setting.
PSx >/< CalcMeasMag/ MagSet at the moment	-5 000 000...5 000 000	The ratio between calculated magnitude and the pick-up setting.

## Pick-up settings

The *Pick-up setting Mag* setting parameter controls the pick-up of the PSx>/< function. This defines the maximum or minimum allowed measured magnitude before action from the function. The function constantly calculates the ratio between the set and the measured magnitudes. The user can set the reset hysteresis in the function (by default 3 %). It is always relative to the *Pick-up setting Mag* value.

Table. 4.4.11 - 102. Pick-up settings.

Name	Range	Step	Default	Description
PS# Pick-up term Mag#	<ul style="list-style-type: none"> <li>Over &gt;</li> <li>Over (abs) &gt;</li> <li>Under &lt;</li> <li>Under (abs) &lt;</li> <li>Delta set (%) +/- &gt;</li> <li>Delta abs (%) &gt;</li> <li>Delta +/- measval</li> <li>Delta abs measval</li> </ul>	-	Over	Comparator mode for the magnitude. See "Comparator modes" section below for more information.
PS# Pick-up setting Mag#/calc >/<	-5 000 000.0000...5 000 000.0000	0.0001	0.01	Pick-up magnitude
PS# Setting hysteresis Mag#	0.0000...50.0000%	0.0001%	3%	Setting hysteresis
Definite operating time delay	0.000...1800.000s	0.005s	0.04s	Delay setting
Release time delays	0.000...1800.000s	0.005s	0.06s	Pick-up release delay

## Comparator modes

When setting the comparators, the user must first choose a comparator mode.

Table. 4.4.11 - 103. Comparator modes

Mode	Description
Over >	<b>Greater than.</b> If the measured signal is greater than the set pick-up level, the comparison condition is fulfilled.
Over (abs) >	<b>Greater than (absolute).</b> If the absolute value of the measured signal is greater than the set pick-up level, the comparison condition is fulfilled.
Under <	<b>Less than.</b> If the measured signal is less than the set pick-up level, the comparison condition is fulfilled. The user can also set a blocking limit: the comparison is not active when the measured value is less than the set blocking limit.
Under (abs) <	<b>Less than (absolute).</b> If the absolute value of the measured signal is less than the set pick-up level, the comparison condition is fulfilled. The user can also set a blocking limit: the comparison is not active when the measured value is less than the set blocking limit.

Mode	Description
Delta set (%) +/- >	<b>Relative change over time.</b> If the measured signal changes more than the set relative pick-up value in 20 ms, the comparison condition is fulfilled. The condition is dependent on direction.
Delta abs (%) >	<b>Relative change over time (absolute).</b> If the measured signal changes more than the set relative pick-up value in 20 ms in either direction, the comparison condition is fulfilled. The condition is not dependent on direction.
Delta +/- measval	<b>Change over time.</b> If the measured signal changes more than the set pick-up value in 20 ms, the comparison condition is fulfilled. The condition is dependent on direction.
Delta abs measval	<b>Change over time (absolute).</b> If the measured signal changes more than the set pick-up value in 20 ms in either direction, the comparison condition is fulfilled. The condition is not dependent on direction.

The pick-up level is set individually for each comparison. When setting up the pick-up level, the user needs to take into account the modes in use as well as the desired action. The pick-up limit can be set either as positive or as negative. Each pick-up level has a separate hysteresis setting which is 3 % by default.

The user can set the operating and releasing time delays for each stage.

### Function blocking

The blocking signal is evaluated at the start of each program cycle. The blocking signals are connected to the function's dedicated input, which can be configured in the *IO → Blocking Input Control* tab of the function.

- When the pick-up element activates and the blocking signal is not active, a START signal is generated, and the function starts or continues with the trip time countdown.
- When the pick-up element activates and the blocking signal is active, a BLOCKED signal is generated, and the function does not process the event further.
- When a START signal is already active and the blocking input signal becomes active, the START signal is reset and BLOCKED signal is generated. The release time characteristics are then processed in the same way as when the pick-up signal is reset.

The blocking signal needs to reach the device minimum of 5 ms before the set operating delay has passed in order for the blocking to activate in time.

### Events and registers

The programmable stage function (abbreviated "PSx" in event block names) generates events and registers from the status changes in the events listed below. The user can select which event messages are stored in the main event buffer: ON, OFF, or both. The events triggered by the function are recorded with a time stamp.

The function's outputs can be used for direct I/O controlling and user logic programming. The function also provides a resettable cumulative counter for the START, TRIP and BLOCKED events.

Table. 4.4.11 - 104. Event messages.

Event block name	Event names
PSx	PS1...10 >/< Start ON/OFF

Event block name	Event names
PSx	PS1...10 >/< Trip ON/OFF
PSx	PS1...10 >/< Block ON/OFF

The function registers its operation into the last twelve (12) time-stamped registers. The register of the function records the ON event process data for START, TRIP or BLOCKED. The table below presents the structure of the function's register content.

Table. 4.4.11 - 105. Register content.

Register	Description
Date and time	dd.mm.yyyy hh:mm:ss.mss
Event	Event name
>/< Mag#	The numerical value of the magnitude
Mag#/Set#	Ratio between the measured magnitude and the pick-up setting
Trip time remaining	0 ms...1800s
Setting group in use	Setting group 1...8 active

## 4.5 Control functions

### 4.5.1 Common signals

Common signals function has all protection function start and trip signals internally connected to Common START and TRIP output signals. When any of the activated protection functions generate a START or a TRIP signal, Common signals function will also generate the same signal.

#### General settings

The following general settings define the general behavior of the function. These settings are static i.e. it is not possible to change them by editing the setting group.

Table. 4.5.1 - 106. General settings of the function.

Name	Range	Default	Description
Common force status to	<ul style="list-style-type: none"> <li>• Normal</li> <li>• Start</li> <li>• Trip</li> </ul>	Normal	Force the status of the function. Visible only when <i>Enable stage forcing</i> parameter is enabled in <i>General</i> menu.

Common signals function has all START and TRIP signals of protection functions internally connected to Common START and TRIP output signals. But it is also possible to assign extra signals to activate Common START and TRIP.

Table. 4.5.1 - 107. Common signals extra inputs.

Name	Description
Common Start In	Assign extra signals to activate common START signal. Please note that all protection function START signals are already assigned internally to Common START.
Common Trip In	Assign extra signals to activate common TRIP signal. Please note that all protection function TRIP signals are already assigned internally to Common TRIP.

### Read-only parameters

The function's *Info* page displays useful, real-time information on the state of the protection function. It is accessed either through the device's HMI display, or through the setting tool software when it is connected to the device and its Live Edit mode is active.

Table. 4.5.1 - 108. Information displayed by the function.

Name	Range	Description
Common signals condition	<ul style="list-style-type: none"> <li>• Normal</li> <li>• Start</li> <li>• Trip</li> </ul>	Displays status of the function.

### Function blocking

Common signals function itself doesn't have blocking input signals. Blocking of tripping should be done in each protection function settings.

### Events

The common signals function (abbreviated "GNSIG" in event block names) generates events from the status changes in the events listed below. The user can select which event messages are stored in the main event buffer: ON, OFF, or both.

The function's outputs can be used for direct I/O controlling and user logic programming. The function also provides a resettable cumulative counter for the START and TRIP events.

The events triggered by the function are recorded with a time stamp.

Table. 4.5.1 - 109. Event messages.

Event block name	Event names
GNSIG	Common Start ON/OFF
GNSIG	Common Trip ON/OFF

## 4.5.2 Setting group selection

All device types support up to eight (8) separate setting groups. The Setting group selection function block controls the availability and selection of the setting groups. By default, only Setting group 1 (SG1) is active and therefore the selection logic is idle. When more than one setting group is enabled, the setting group selector logic takes control of the setting group activations based on the logic and conditions the user has programmed.

Figure. 4.5.2 - 58. Simplified function block diagram of the setting group selection function.

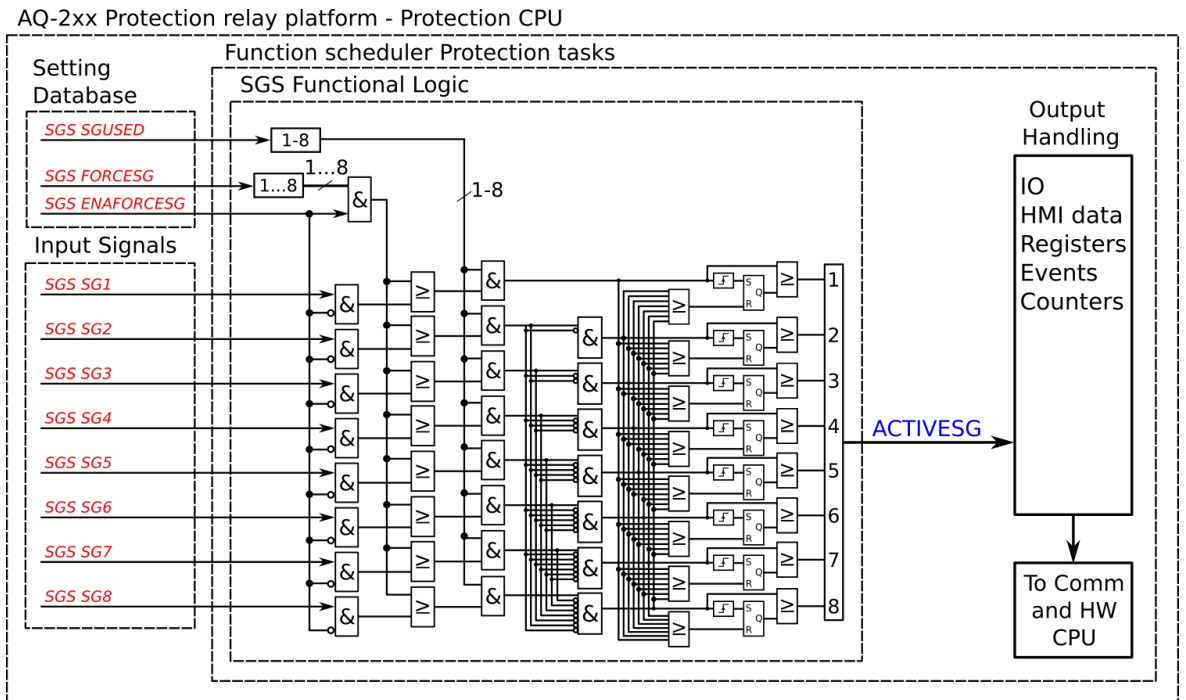

Setting group selection can be applied to each of the setting groups individually by activating one of the various internal logic inputs and connected digital inputs. The user can also force any of the setting groups on when the "Force SG change" setting is enabled by giving the wanted quantity of setting groups as a number in the communication bus or in the local HMI, or by selecting the wanted setting group from *Control* → *Setting groups*. When the forcing parameter is enabled, the automatic control of the local device is overridden and the full control of the setting groups is given to the user until the "Force SG change" is disabled again.

Setting groups can be controlled either by pulses or by signal levels. The setting group controller block gives setting groups priority values for situations when more than one setting group is controlled at the same time: the request from a higher-priority setting group is taken into use.

Setting groups follow a hierarchy in which setting group 1 has the highest priority, setting group 2 has second highest priority etc. If a static activation signal is given for two setting groups, the setting group with higher priority will be active. If setting groups are controlled by pulses, the setting group activated by pulse will stay active until another setting groups receives and activation signal.

Figure. 4.5.2 - 59. Example sequences of group changing (control with pulse only, or with both pulses and static signals).

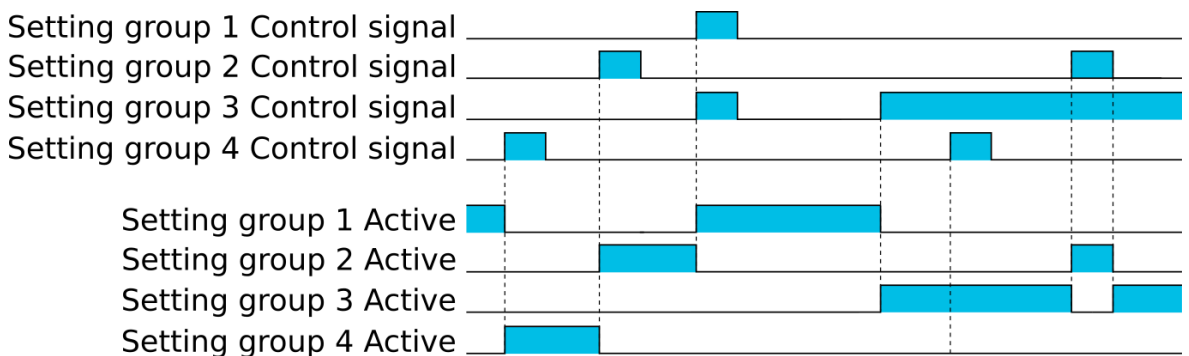

## Settings and signals

The settings of the setting group control function include the active setting group selection, the forced setting group selection, the enabling (or disabling) of the forced change, the selection of the number of active setting groups in the application, as well as the selection of the setting group changed remotely. If the setting group is forced to change, the corresponding setting group must be enabled and the force change must be enabled. Then, the setting group can be set from communications or from HMI to any available group. If the setting group control is applied with static signals right after the "Force SG" parameter is released, the application takes control of the setting group selection.

Table. 4.5.2 - 110. Settings of the setting group selection function.

Name	Range	Default	Description
Active setting group	<ul style="list-style-type: none"> <li>• SG1</li> <li>• SG2</li> <li>• SG3</li> <li>• SG4</li> <li>• SG5</li> <li>• SG6</li> <li>• SG7</li> <li>• SG8</li> </ul>	SG1	Displays which setting group is active.
Force setting group	<ul style="list-style-type: none"> <li>• None</li> <li>• SG1</li> <li>• SG2</li> <li>• SG3</li> <li>• SG4</li> <li>• SG5</li> <li>• SG6</li> <li>• SG7</li> <li>• SG8</li> </ul>	None	The selection of the overriding setting group. After "Force SG change" is enabled, any of the configured setting groups in the device can be overridden. This control is always based on the pulse operating mode. It also requires that the selected setting group is specifically controlled to ON after "Force SG" is disabled. If there are no other controls, the last set setting group remains active.
Force setting group change	<ul style="list-style-type: none"> <li>• Disabled</li> <li>• Enabled</li> </ul>	Disabled	The selection of whether the setting group forcing is enabled or disabled. This setting has to be active before the setting group can be changed remotely or from a local HMI. This parameter overrides the local control of the setting groups and it remains on until the user disables it.
Used setting groups	<ul style="list-style-type: none"> <li>• SG1</li> <li>• SG1...2</li> <li>• SG1...3</li> <li>• SG1...4</li> <li>• SG1...5</li> <li>• SG1...6</li> <li>• SG1...7</li> <li>• SG1...8</li> </ul>	SG1	The selection of the activated setting groups in the application. Newly-enabled setting groups use default parameter values.
Remote setting group change	<ul style="list-style-type: none"> <li>• None</li> <li>• SG1</li> <li>• SG2</li> <li>• SG3</li> <li>• SG4</li> <li>• SG5</li> <li>• SG6</li> <li>• SG7</li> <li>• SG8</li> </ul>	None	This parameter can be controlled through SCADA to change the setting group remotely. Please note that if a higher priority setting group is being controlled by a signal, a lower priority setting group cannot be activated with this parameter.

Table. 4.5.2 - 111. Signals of the setting group selection function.

Name	Description
Setting group 1	The selection of Setting group 1 ("SG1"). Has the highest priority input in setting group control. Can be controlled with pulses or static signals. If static signal control is applied, no other SG requests will be processed.
Setting group 2	The selection of Setting group 2 ("SG2"). Has the second highest priority input in setting group control. Can be controlled with pulses or static signals. If static signal control is applied, no requests with a lower priority than SG1 will be processed.
Setting group 3	The selection of Setting group 3 ("SG3"). Has the third highest priority input in setting group control. Can be controlled with pulses or static signals. If static signal control is applied, no requests with a lower priority than SG1 and SG2 will be processed.
Setting group 4	The selection of Setting group 4 ("SG4"). Has the fourth highest priority input in setting group control. Can be controlled with pulses or static signals. If static signal control is applied, no requests with a lower priority than SG1, SG2 and SG3 will be processed.
Setting group 5	The selection of Setting group 5 ("SG5"). Has the fourth lowest priority input in setting group control. Can be controlled with pulses or static signals. If static signal control is applied, SG6, SG7 and SG8 requests will not be processed.
Setting group 6	The selection of Setting group 6 ("SG6"). Has the third lowest priority input in setting group control. Can be controlled with pulses or static signals. If static signal control is applied, SG7 and SG8 requests will not be processed.
Setting group 7	The selection of Setting group 7 ("SG7"). Has the second lowest priority input in setting group control. Can be controlled with pulses or static signals. If static signal control is applied, only SG8 requests will not be processed.
Setting group 8	The selection of Setting group 8 ("SG8"). Has the lowest priority input in setting group control. Can be controlled with pulses or static signals. If static signal control is applied, all other SG requests will be processed regardless of the signal status of this setting group.

## Events

The setting group selection function block (abbreviated "SGS" in event block names) generates events from the status changes in the events listed below. The user can select which event messages are stored in the main event buffer: ON, OFF, or both. The events triggered by the function are recorded with a time stamp.

Table. 4.5.2 - 112. Event messages.

Event block name	Event names
SGS	SG2...8 Enabled/Disabled
SGS	SG1...8 Request ON/OFF
SGS	Remote Change SG Request ON/OFF
SGS	Local Change SG Request ON/OFF
SGS	Force Change SG ON/OFF
SGS	SG Request Fail Not configured SG ON/OFF
SGS	Force Request Fail Force ON/OFF

Event block name	Event names
SGS	SG Req. Fail Lower priority Request ON/OFF
SGS	SG1...8 Active ON/OFF

### 4.5.3 Object control and monitoring

The object control and monitoring function takes care of both for circuit breakers and disconnectors. The monitoring and controlling are based on the statuses of the device's configured digital inputs and outputs. The number of controllable and monitored objects in each device depends on the device type and amount of digital inputs. One controllable object requires a minimum of two (2) output contacts. The status monitoring of one monitored object usually requires two (2) digital inputs. Alternatively, object status monitoring can be performed with a single digital input: the input's active state and its zero state (switched to 1 with a NOT gate in the Logic editor).

An object can be controlled manually or automatically. Manual control can be done by local control, or by remote control. Local manual control can be done by devices front panel (HMI) or by external push buttons connected to devices digital inputs. Manual remote control can be done through one of the various communication protocols available (Modbus, IEC101/103/104 etc.). The function supports the modes "Direct control" and "Select before execute" while controlled remotely. Automatic controlling can be done with functions like auto-reclosing function (ANSI 79).

The main outputs of the function are the OBJECT OPEN and OBJECT CLOSE control signals. Additionally, the function reports the monitored object's status and applied operations. The setting parameters are static inputs for the function, which can only be changed by the user in the function's setup phase.

Figure. 4.5.3 - 60. Simplified function block diagram of the object control and monitoring function.

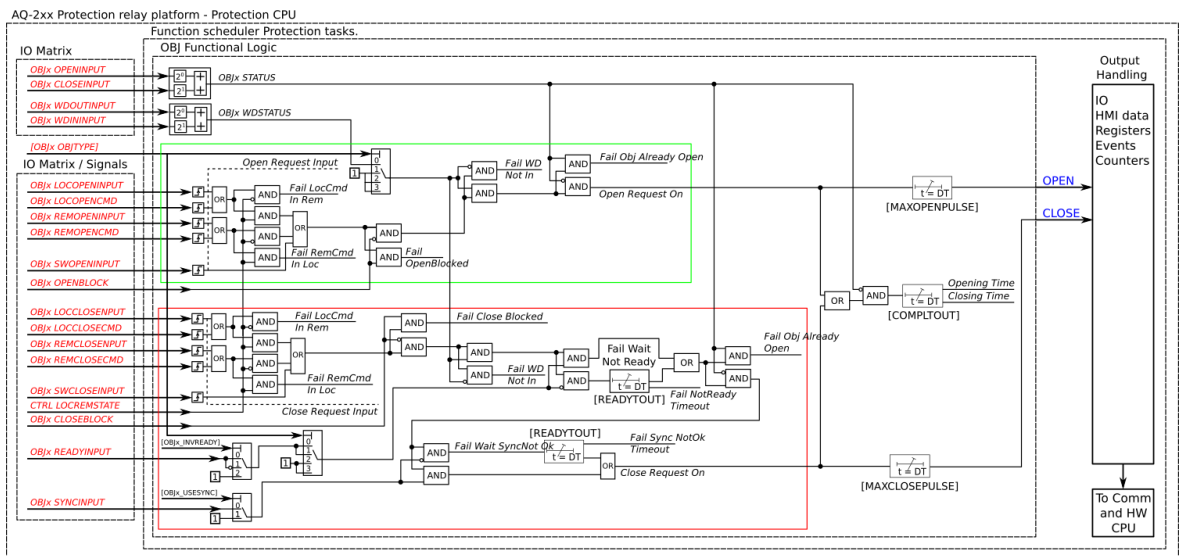

### Settings

The following parameters help the user to define the object. The operation of the function varies based on these settings and the selected object type. The selected object type determines how much control is needed and which setting parameters are required to meet those needs.

Table. 4.5.3 - 113. Object settings and status parameters.

Name	Range	Default	Description
Local/Remote status	<ul style="list-style-type: none"> <li>Local</li> <li>Remote</li> </ul>	Remote	Displays the status of the device's "local/remote" switch. Local controls cannot override the open and close commands while device is in "Remote" status. The remote controls cannot override the open and close commands while device is in "Local" status.
Object status force to	<ul style="list-style-type: none"> <li>Normal</li> <li>Openreq On</li> <li>Closerreq On</li> <li>Opensignal On</li> <li>Closesignal On</li> <li>WaitNoRdy On</li> <li>WaitNoSnc On</li> <li>NotrdyFail On</li> <li>NosyncFail On</li> <li>Opentout On</li> <li>Clotout On</li> <li>OpenreqUSR On</li> <li>CloreqUSR On</li> </ul>	Normal	Force the status of the function. Visible only when <i>Enable stage forcing</i> parameter is enabled in <i>General</i> menu.
OBJ LN mode	<ul style="list-style-type: none"> <li>On</li> <li>Blocked</li> <li>Test</li> <li>Test/Blocked</li> <li>Off</li> </ul>	On	Set mode of OBJ block. This parameter is visible only when <i>Allow setting of individual LN mode</i> is enabled in <i>General</i> menu.
OBJ LN behaviour	<ul style="list-style-type: none"> <li>On</li> <li>Blocked</li> <li>Test</li> <li>Test/Blocked</li> <li>Off</li> </ul>	-	Displays the mode of OBJ block. This parameter is visible only when <i>Allow setting of individual LN mode</i> is enabled in <i>General</i> menu.
Object name	-	Objectx	The user-set name of the object, at maximum 32 characters long.
Object type	<ul style="list-style-type: none"> <li>Withdrawable circuit breaker</li> <li>Circuit breaker</li> <li>Disconnecter (MC)</li> <li>Disconnecter (GND)</li> </ul>	Circuit breaker	The selection of the object type. This selection defines the number of required digital inputs for the monitored object. This affects the symbol displayed in the HMI and the monitoring of the circuit breaker. It also affects whether the withdrawable cart is in/out status is monitored. See the next table ("Object types") for a more detailed look at which functionalities each of the object types have.
Objectx Breaker status	<ul style="list-style-type: none"> <li>Intermediate</li> <li>Open</li> <li>Closed</li> <li>Bad</li> </ul>	-	Displays the status of breaker. Intermediate is displayed when neither of the status signals (open or close) are active. Bad status is displayed when both status signals (open and close) are active.
Objectx Withdraw status	<ul style="list-style-type: none"> <li>WDIntermediate</li> <li>WDCartOut</li> <li>WDCart In</li> <li>WDBad</li> <li>Not in use</li> </ul>	-	Displays the status of circuit breaker cart. WDIntermediate is displayed when neither of the status signals (in or out) are active. WDBad status is displayed when both status signals (in and out) are active. If the selected object type is not set to "Withdrawable circuit breaker", this setting displays the "No in use" option.

Name	Range	Default	Description
Additional status information	<ul style="list-style-type: none"> <li>Open Blocked</li> <li>Open Allowed</li> <li>Close Blocked</li> <li>Close Allowed</li> <li>Object Ready</li> <li>Object Not Ready</li> <li>Sync Ok</li> <li>Sync Not Ok</li> </ul>	-	Displays additional information about the status of the object.
Use Synchrocheck	<ul style="list-style-type: none"> <li>Not in use</li> <li>Synchrocheck in use</li> </ul>	Not in use	Selects whether the "Synchrocheck" condition is in use for the circuit breaker close command. If "In use" is selected the input chosen to "Sync.check status in" has to be active to be able to close circuit breaker. Synchrocheck status can be either an internal signal generated by synchrocheck function or digital input activation with an external synchrocheck device.
Use Object ready	<ul style="list-style-type: none"> <li>Ready High</li> <li>Ready Low</li> <li>Not in use</li> </ul>	Not in use	Selects whether the "Object ready" condition is in use for the circuit breaker close command. If in use the signal connected to "Object ready status In" has to be high or low to be able to close the breaker (depending on "Ready High or Low" selection).
Open requests	$0 \dots 2^{32} - 1$	-	Displays the number of successful "Open" requests.
Close requests	$0 \dots 2^{32} - 1$	-	Displays the number of successful "Close" requests.
Open requests failed	$0 \dots 2^{32} - 1$	-	Displays the number of failed "Open" requests.
Close requests failed	$0 \dots 2^{32} - 1$	-	Displays the number of failed "Close" requests.
Clear statistics	<ul style="list-style-type: none"> <li>-</li> <li>Clear</li> </ul>	-	Clears the request statistics, setting them back to zero (0). Automatically returns to "-" after the clearing is finished.

Table. 4.5.3 - 114. Object types.

Name	Functionalities	Description
Withdrawable circuit breaker	Breaker cart position Circuit breaker position Circuit breaker control Object ready check before closing breaker Synchrochecking before closing breaker Interlocks	The monitor and control configuration of the withdrawable circuit breaker.

Name	Functionalities	Description
Circuit breaker	Position indication Control Object ready check before closing breaker Synchrochecking before closing breaker Interlocks	The monitor and control configuration of the circuit breaker.
Disconnecter (MC)	Position indication Control	The position monitoring and control of the disconnecter.
Disconnecter (GND)	Position indication	The position indication of the earth switch.

Table. 4.5.3 - 115. I/O.

Signal	Range	Description
Objectx Open Status In	Digital input or other logical signal selected by the user (SWx)	A link to a physical digital input. The monitored object's OPEN status. "1" refers to the active open state of the monitored object.
Objectx Close Status In		A link to a physical digital input. The monitored object's CLOSE status. "1" refers to the active close state of the monitored object.
Withdrw.CartIn.Status In		A link to a physical digital input. The monitored withdrawable object's position is IN. "1" means that the withdrawable object cart is in.
Withdrw.CartOut.Status In		A link to a physical digital input. The monitored withdrawable object's position is OUT. "1" means that the withdrawable object cart is pulled out.
Objectx Ready status In		A link to a physical digital input. Indicates that status of the monitored object. "1" means that the object is ready and the spring is charged for a close command.
Sync.Check status In		A link to a physical digital input or a synchrocheck function. "1" means that the synchrocheck conditions are met and the object can be closed.
Objectx Open Command	OUT1...OUTx	The physical "Open" command pulse to the device's output relay.
Objectx Close Command		The physical "Close" command pulse to the device's output relay.

Table. 4.5.3 - 116. Operation settings.

Name	Range	Step	Default	Description
Breaker traverse time	0.02...500.00 s	0.02 s	0.2 s	Determines the maximum time between open and close statuses when the breaker switches. If this set time is exceeded and both open and closed status inputs are active, the status "Bad" is activated in the "Objectx Breaker status" setting. If neither of the status inputs are active after this delay, the status "Intermediate" is activated.

Name	Range	Step	Default	Description
Sync wait timeout	0.02...500.00 s	0.02 s	0.2 s	If synchrocheck is used, the object will wait for a "synchrocheck ok" signal before giving the closing command. This parameter will cancel the command if synchronization is not achieved on time.
Maximum Close command pulse length	0.02...500.00 s	0.02 s	0.2 s	Determines the maximum length for a Close pulse from the output relay to the controlled object. If the object operates faster than this set time, the control pulse is reset and a status change is detected.
Maximum Open command pulse length	0.02...500.00 s	0.02 s	0.2 s	Determines the maximum length for a Open pulse from the output relay to the controlled object. If the object operates faster than this set time, the control pulse is reset and a status change is detected.
Control termination timeout	0.02...500.00 s	0.02 s	10 s	Determines the control pulse termination timeout. If the object has not changed its status in this given time the function will issue an error event and the control is ended. This parameter is common for both open and close commands.
Final trip pulse length	0.00...500.00 s	0.02 s	0.2 s	Determines the length of the final trip pulse length. When the object has executed the final trip, this signal activates. If set to 0 s, the signal is continuous. If auto-recloser function controls the object, "final trip" signal is activated only when there are no automatic reclosings expected after opening the breaker.

Table. 4.5.3 - 117. Control settings (DI and Application).

Signal	Range	Description
Access level for MIMIC control	<ul style="list-style-type: none"> <li>User</li> <li>Operator</li> <li>Configurator</li> <li>Super user</li> </ul>	Defines what level of access is required for MIMIC control. The default is the "Configurator" level.
Objectx LOCAL Close control input	Digital input or other logical signal selected by the user	The local Close command from a physical digital input (e.g. a push button).
Objectx LOCAL Open control input		The local Open command from a physical digital input (e.g. a push button).
Objectx REMOTE Close control input		The remote Close command from a physical digital input (e.g. RTU).
Objectx REMOTE Open control input		The remote Open command from a physical digital input (e.g. RTU).
Objectx Application Close		The Close command from the application. Can be any logical signal.
Objectx Application Open		The Close command from the application. Can be any logical signal.

## Blocking and interlocking

The interlocking and blocking conditions can be set for each controllable object, with Open and Close set separately. Blocking and interlocking can be based on any of the following: other object statuses, a software function or a digital input.

In order for the blocking signal to be received on time, it has to reach the function 5 ms before the control command.

### Trip circuit supervision

Trip circuit supervision monitors the wiring from auxiliary power supply, through the device's digital output, and all the way to the open coil of the breaker. It is recommended to supervise the health of the trip circuit when breaker is closed.

The figure below presents an application scheme for trip circuit supervision with one digital input and a non-latched trip output. With this connection the current keeps flowing to the open coil of the breaker via the breaker's closing auxiliary contacts (52b) even after the circuit breaker is opened. This requires a resistor which reduces the current: this way the coil is not energized and the relay output does not need to cut off the coil's inductive current.

Figure. 4.5.3 - 61. Trip circuit supervision with one DI and one non-latched trip output.

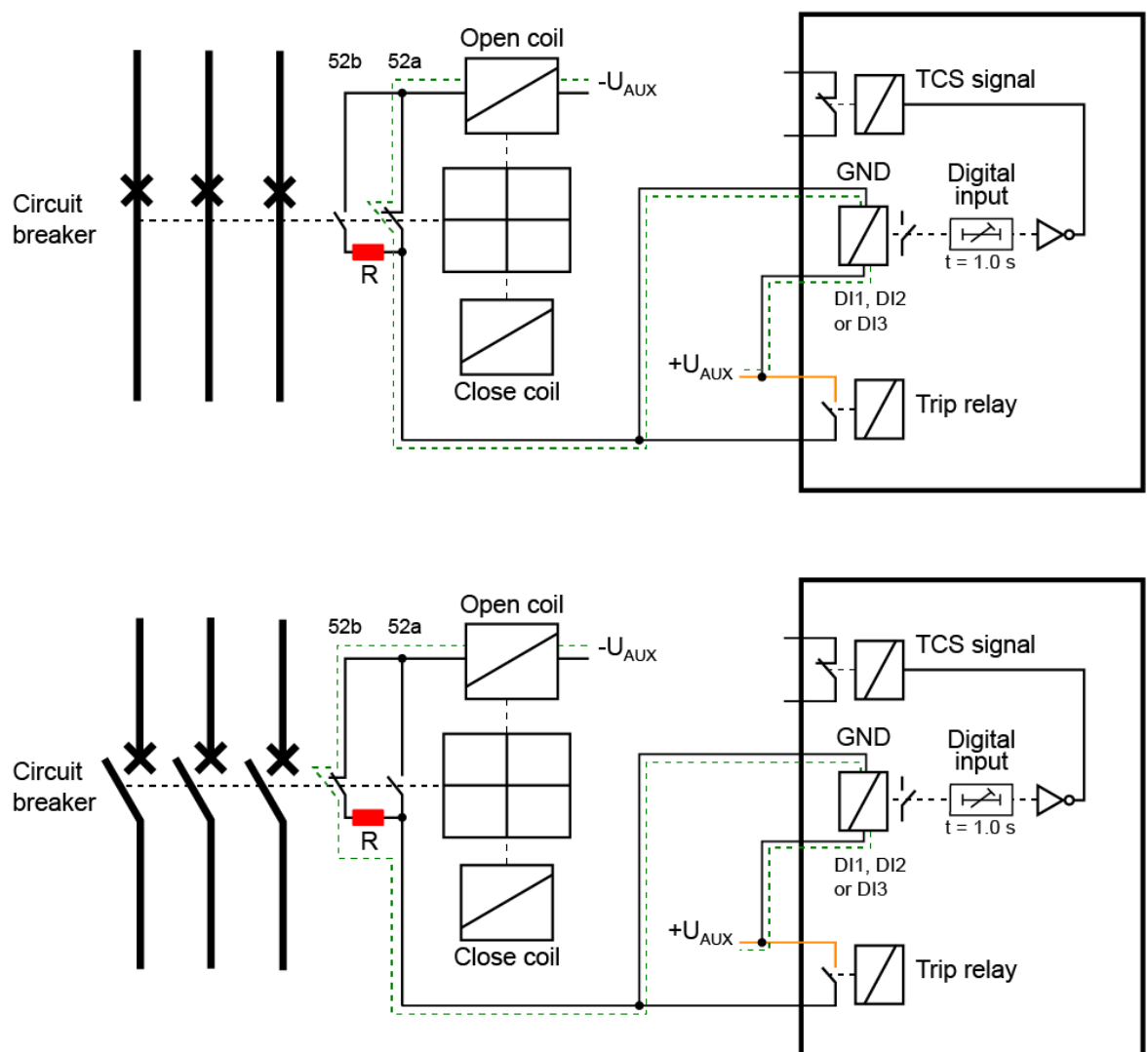

Note that the digital input that monitors the circuit is normally closed, and the same applies to the alarm relay if one is used. For monitoring and especially trip circuit supervision purposes it is recommended to use a normally closed contact to confirm the wiring's condition. An active digital input generates a less than 2 mA current to the circuit, which is usually small enough not to make the breaker's open coil operate.

When the trip relay is controlled and the circuit breaker is opening, the digital input is shorted by the trip contact as long as the breaker opens. Normally, this takes about 100 ms if the relay is non-latched. A one second activation delay should, therefore, be added to the digital input. An activation delay that is slightly longer than the circuit breaker's operations time should be enough. When circuit breaker failure protection (CBFP) is used, adding its operation time to the digital input activation time is useful. The whole digital input activation time is, therefore,  $t_{DI} = t_{CB} + t_{IEDrelease} + t_{CBFP}$ .

Figure. 4.5.3 - 62. Trip circuit supervision with high-speed output. High-speed outputs have an internal input for trip circuit supervision.

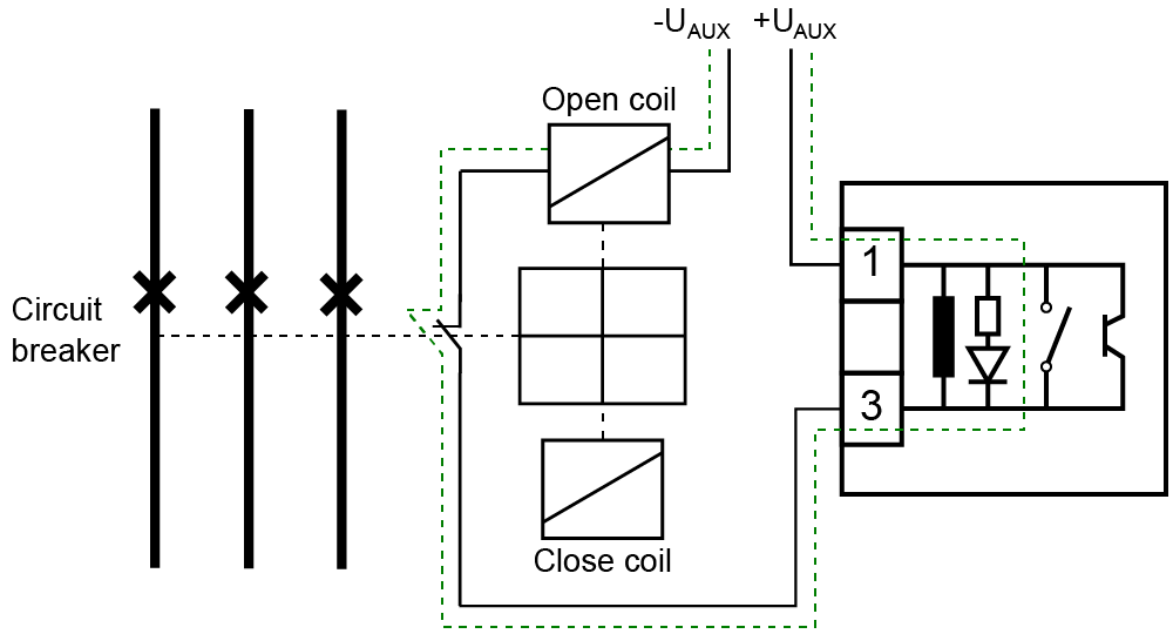

Table. 4.5.3 - 118. Trip circuit supervision settings (Control → Objects → Object X → APP CONTR → Condition monitoring).

Name	Range	Default	Description
ObjectX Trip circuit supervision	<ul style="list-style-type: none"> <li>Disabled</li> <li>Enabled</li> </ul>	Disabled	Enables the trip circuit supervision function.
ObjectX TCS Alarm activation delay	0.02...500.00 s	0.20 s	Time delay before TCS alarm is activated.
Object1 TCS input	-	-	Defines the supervised digital input, high-speed output or other signal.

### Events and registers

The object control and monitoring function (abbreviated "OBJ" in event block names) generates events and registers from the status changes in the events listed below. The user can select which event messages are stored in the main event buffer: ON, OFF, or both. The events triggered by the function are recorded with a time stamp.

The function also provides a resettable cumulative counter for OPEN, CLOSE, OPEN FAILED, and CLOSE FAILED events.

Table. 4.5.3 - 119. Event messages of the OBJ function.

Event block name	Description
OBJX	Object Intermediate
OBJX	Object Open
OBJX	Object Close
OBJX	Object Bad
OBJX	WD Intermediate
OBJX	WD Out
OBJX	WD in
OBJX	WD Bad
OBJX	Open Request ON/OFF
OBJX	Open Command ON/OFF
OBJX	Close Request ON/OFF
OBJX	Close Command ON/OFF
OBJX	Open Blocked ON/OFF
OBJX	Close Blocked ON/OFF
OBJX	Object Ready
OBJX	Object Not Ready
OBJX	Sync Ok
OBJX	Sync Not Ok
OBJX	Open Command Fail
OBJX	Close Command Fail
OBJX	Final trip ON/OFF
OBJX	Contact Abrasion Alarm ON/OFF
OBJX	Switch Operating Time Exceeded ON/OFF
OBJX	XCBR Loc ON/OFF
OBJX	XSWI Loc ON/OFF
OBJX	OBJX Cond monitoring alarm 1 ON/OFF
OBJX	OBJX Cond monitoring alarm 2 ON/OFF
OBJX	OBJX Trip Circuit Supervision ON/OFF

The function registers its operation into the last twelve (12) time-stamped registers. The table below presents the structure of the function's register content.

Table. 4.5.3 - 120. Register content.

Name	Description
Date and time	dd.mm.yyyy hh:mm:ss.mss
Event	Event name
Recorded Object opening time	Time difference between the object receiving an "Open" command and the object receiving the "Open" status.
Recorded Object closing time	Time difference between the object receiving a "Close" command and object receiving the "Closed" status.
Object status	The status of the object.
WD status	The status of the withdrawable circuit breaker.
Open fail	The cause of an "Open" command's failure.
Close fail	The cause of a "Close" command's failure.
Open command	The source of an "Open" command.
Close command	The source of an "Open" command.
General status	The general status of the function.

## 4.5.4 Indicator object monitoring

The indicator object monitoring function takes care of the status monitoring of disconnectors. The function's sole purpose is indication and does not therefore have any control functionality. To control circuit breakers and/or disconnectors, please use the Object control and monitoring function. The monitoring is based on the statuses of the configured device's digital inputs. The number of monitored indicators in a device depends on the device type and available inputs. The status monitoring of one monitored object usually requires two (2) digital inputs. Alternatively, object status monitoring can be performed with a single digital input: the input's active state and its zero state (switched to 1 with a NOT gate in the Logic editor).

The outputs of the function are the monitored indicator statuses (Open, Close, Intermediate and Bad). The setting parameters are static inputs for the function, which can only be changed by the use in the function's setup phase.

The inputs of the function are the binary status indications. The function generates general time stamped ON/OFF events to the common event buffer from each of the following signals: OPEN, CLOSE, BAD and INTERMEDIATE event signals. The time stamp resolution is 1 ms.

### Settings

Function uses available hardware and software digital signal statuses. These input signals are also setting parameters for the function.

Table. 4.5.4 - 121. Indicator status.

Name	Range	Default	Description
Indicator name ("Ind. Name")	-	IndX	The user-set name of the object, at maximum 32 characters long.
IndicatorX Object status ("Ind.X Object Status")	<ul style="list-style-type: none"> <li>• Intermediate</li> <li>• Open</li> <li>• Closed</li> <li>• Bad</li> </ul>	-	Displays the status of the indicator object. Intermediate status is displayed when neither of the status conditions (open or close) are active. Bad status is displayed when both of the status conditions (open and close) are active.

Table. 4.5.4 - 122. Indicator I/O.

Signal	Range	Description
IndicatorX Open input ("Ind.X Open Status In")	Digital input or other logical signal selected by the user (SWx)	A link to a physical digital input. The monitored indicator's OPEN status. "1" refers to the active "Open" state of the monitored indicator.
IndicatorX Close input ("Ind.X Close Status In")	Digital input or other logical signal selected by the user (SWx)	A link to a physical digital input. The monitored indicator's CLOSE status. "1" refers to the active "Close" state of the monitored indicator.

## Events

The indicator object monitoring function (abbreviated "CIN" in event block names) generates events from the status changes in the events listed below. The user can select which event messages are stored in the main event buffer: ON, OFF, or both. The events triggered by the function are recorded with a time stamp.

Table. 4.5.4 - 123. Event messages (instances 1-10).

Event block name	Event names
CIN1...10	Intermediate
CIN1...10	Open
CIN1...10	Close
CIN1...10	Bad

### 4.5.5 Switch-on-to-fault (SOTF)

The switch-on-to-fault (SOTF) function is used for speeding up the tripping when the breaker is closed towards a fault or forgotten earthing to reduce the damage in the fault location. The function can be used to control protection functions, or it can be used to directly trip a breaker if any of the connected protection functions starts during the set SOTF time. The operation of the function is instant after the conditions are met and any one signal connected to the "Function input" input activates.

The function can be initiated by a digital input, or by a circuit breaker "Close" command connected to the "SOTF activate input" input. The duration of the SOTF-armed condition can be set by the "Release time for SOTF" setting parameter; it can be changed if the application so requires through setting group selection.

Figure. 4.5.5 - 63. Simplified function block diagram of the switch-on-to-fault function.

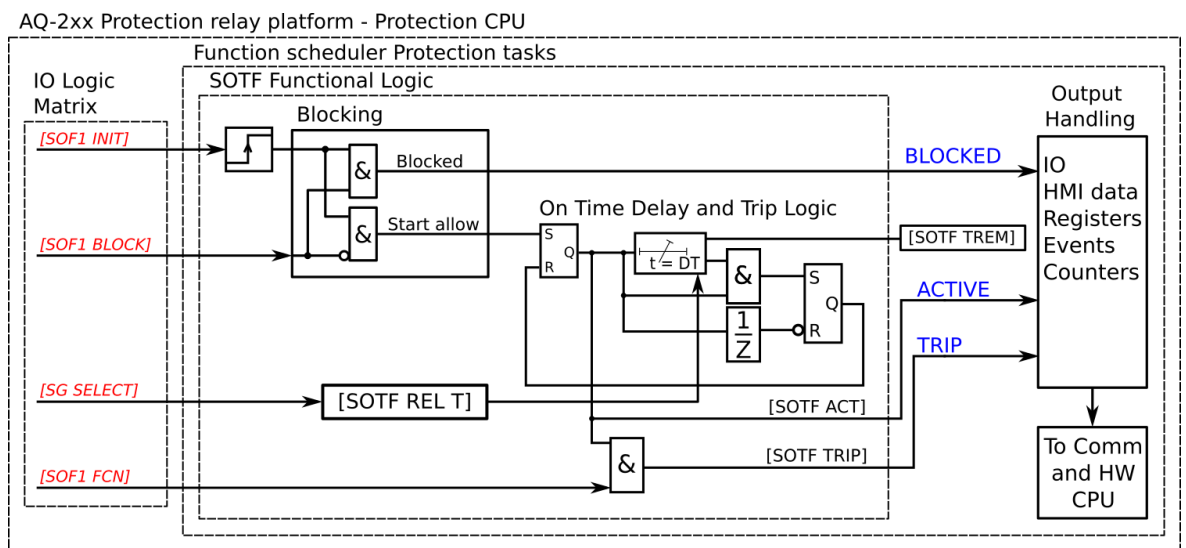

#### Input signals

The function block does not use analog measurement inputs. Instead, its operation is based entirely on binary signal statuses.

Table. 4.5.5 - 124. Input signals.

Input	Description
Activate input	The digital input or logic signal for the function to arm and start calculating the SOTF time. Any binary signal can be used to activate the function and start the calculation. The rising edge of the signal is considered as the start of the function.
Block input	The input for blocking the function. Any binary signal can be used to block the function from starting.
Function input	The function input activates the function's instant trip if applied when the function is calculating the SOTF time.

#### Settings

The switch-on-to-fault function has one setting and it determines how long the function remains active after it has been triggered. If the inputs receive any of the set signals during this time, the function's trip is activated.

Setting group selection controls the operating characteristics of the function, i.e. the user or user-defined logic can change function parameters while the function is running.

Table. 4.5.5 - 125. Settings of the function.

Name	Range	Default	Description
SOTF LN mode	<ul style="list-style-type: none"> <li>• On</li> <li>• Blocked</li> <li>• Test</li> <li>• Test/Blocked</li> <li>• Off</li> </ul>	On	Set mode of SOF block. This parameter is visible only when <i>Allow setting of individual LN mode</i> is enabled in <i>General</i> menu.
SOTF force status to	<ul style="list-style-type: none"> <li>• Normal</li> <li>• Blocked</li> <li>• Active</li> <li>• Trip</li> </ul>	Normal	Force the status of the function. Visible only when <i>Enable stage forcing</i> parameter is enabled in <i>General</i> menu.
Release time for SOTF	0.000...1800.000s	1.000s	The time the function is active after triggering.

### Read-only parameters

The function's *Info* page displays useful, real-time information on the state of the protection function. It is accessed either through the device's HMI display, or through the setting tool software when it is connected to the device and its Live Edit mode is active.

Table. 4.5.5 - 126. Information displayed by the function.

Name	Range	Description
SOTF LN behaviour	<ul style="list-style-type: none"> <li>• On</li> <li>• Blocked</li> <li>• Test</li> <li>• Test/Blocked</li> <li>• Off</li> </ul>	Displays the mode of SOF block. This parameter is visible only when <i>Allow setting of individual LN mode</i> is enabled in <i>General</i> menu.
SOTF condition	<ul style="list-style-type: none"> <li>• Normal</li> <li>• Init</li> <li>• Active</li> <li>• Trip</li> <li>• Blocked</li> </ul>	Displays status of the control function.

### Function blocking

The function can be blocked by activating the BLOCK input. This prevents the function's active time from starting.

### Events and registers

The switch-on-to-fault function (abbreviated "SOF" in event block names) generates events and registers from the status changes in the events listed below. The user can select which event messages are stored in the main event buffer: ON, OFF, or both. The events triggered by the function are recorded with a time stamp.

The function's outputs can be used for direct I/O controlling and user logic programming. The function also provides a resettable cumulative counter for the INIT, BLOCKED, ACTIVE and TRIP events.

Table. 4.5.5 - 127. Event messages.

Event block name	Event names
SOF1	SOTF Init ON/OFF
SOF1	SOTF Block ON/OFF
SOF1	SOTF Active ON/OFF
SOF1	SOTF Trip ON/OFF

The function registers its operation into the last twelve (12) time-stamped registers. The register of the function records the ON process data of ACTIVATED events. The table below presents the structure of the function's register content.

Table. 4.5.5 - 128. Register content.

Register	Description
Date and time	dd.mm.yyyy hh:mm:ss.mss
Event	Event name
Used SG	Setting group 1...8 active
SOTF remaining time	The time remaining of the set release time.
SOTF been active time	The time the function has been active.

## 4.5.6 Vector jump ( $\Delta\phi$ ; 78)

Distribution systems may include different kinds of distributed power generation sources, such as wind farms and diesel or fuel generators. When a fault occurs in the distribution system, it is usually detected and isolated by the protection system closest to the faulty point, resulting in the electrical power system shutting down either partially or completely. The remaining distributed generators try to deliver the power to the part of the distribution system that has been disconnected from the grid, and usually an overload condition can be expected. Under such overload conditions, it is normal to have a drop in voltage and frequency. This overload results in the final system disconnection from the islanding generator(s). The disconnection depends greatly on the ratio between the power generation and the demand of the islanded system. When any power is supplied to a load only from distributed generators, (due to the opening of the main switch), the situation is called an isolated island operation or an islanded operation of the electrical distribution network.

The vector jump control function is suitable to detect most islanding situations and to switch off the mains breaker in order to let the generator only supply loads according to their rated power value. Therefore, an overload does not cause any mechanical stress to the generator unit(s). The vector jump function should be located either on the mains side of the operated breaker or on the islanding generator side.

The vector jump function is used for instant tripping and has only one operating stage. The function has an algorithm which follows the samples of chosen measured voltages (64 samples/cycle). The reference voltage used can be all or any of the phase-to-phase or phase-to-neutral voltages.

Figure. 4.5.6 - 64. Simplified function block diagram of the  $\Delta\phi$  function.

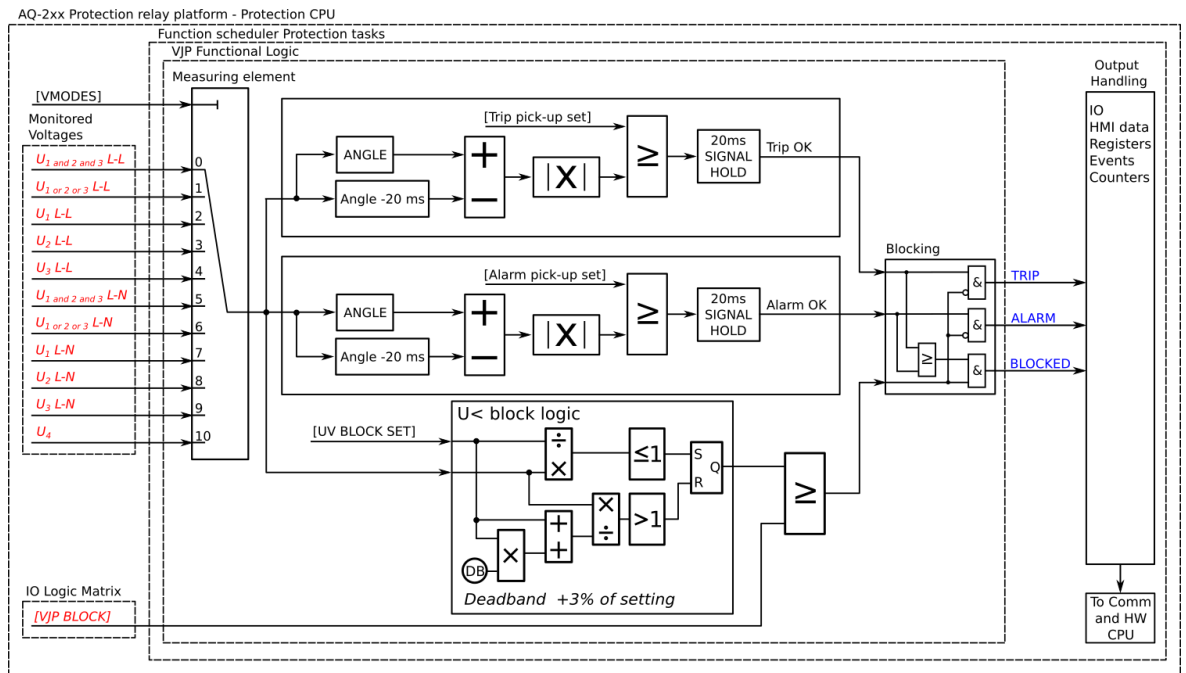

### Measured input

The function block uses phase-to-phase or phase-to-neutral voltages and always uses complex measurement from samples.

Table. 4.5.6 - 129. Measurement inputs of the vector jump function.

Signal	Description
U <sub>1</sub> CMLPX	The complex vector of U <sub>1</sub> /V voltage channel
U <sub>2</sub> CMLPX	The complex vector of U <sub>2</sub> /V voltage channel
U <sub>3</sub> CMLPX	The complex vector of U <sub>3</sub> /V voltage channel
U <sub>4</sub> CMLPX	The complex vector of U <sub>4</sub> /V voltage channel

### Pick-up settings

Setting group selection controls the operating characteristics of the function, i.e. the user or user-defined logic can change function parameters while the function is running.

When a fault appears in the power system and some areas are disconnected, normally the remaining generators connected to the network must supply the area disconnected from the utility side supply. This results in an instantaneous demand of power that the generators must tackle. The excitation and the mechanical systems cannot answer such a huge demand of power quickly even if there were enough reserve power. The worst of the situation is received by the rotors of the generator units: they suffer a torsion torque that can even break the rotor and cause subsequent damage not only for the generator but for the entire power plant too.

Figure. 4.5.6 - 65. Generator islanding.

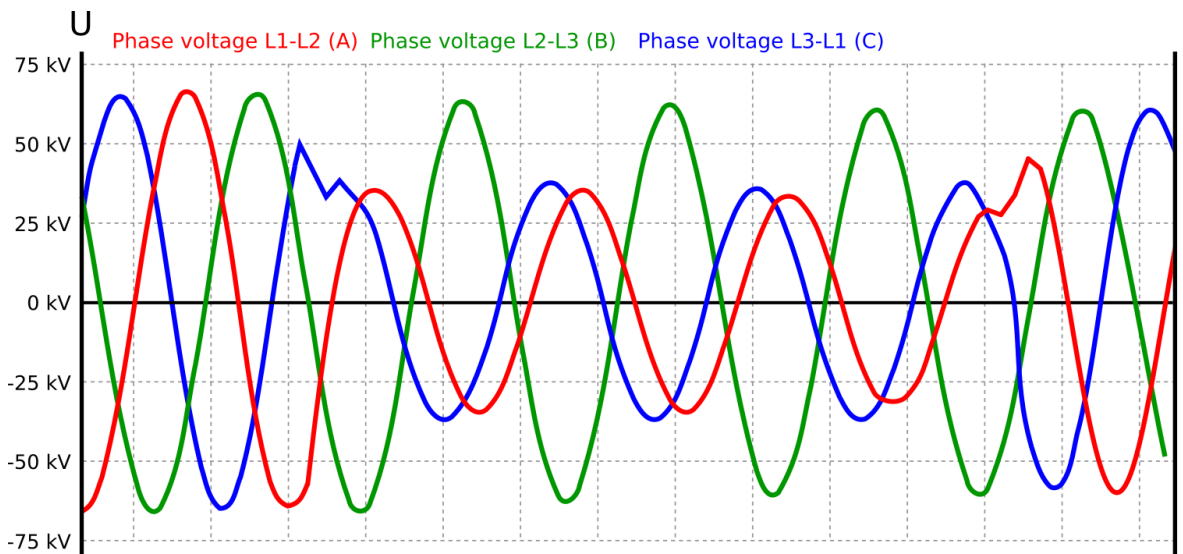

As can be seen in the example above, only phase-to-phase voltages L1-L2 and L3-L1 have been reduced, while voltage L2-L3 remains the same. This means that the problem occurred in phase L1 of the network. The voltage level is not reduced to zero, nor is the voltage in any phase is totally lost. The phases without the fault condition remain normal with the same value. On the other hand, the frequency can sag as can be seen in the figure above.

The  $\Delta\alpha$  setting parameter controls the pick-up of the vector jump function. This defines the minimum allowed rapid measured voltage angle change before action from the function. The function constantly calculates the ratio between the  $\Delta\alpha_{set}$  and the measured magnitude ( $\Delta\alpha_m$ ) for each of the selected voltages. The function's stage trip signal lasts for 20 ms and automatically resets after that time has passed. The setting value is common for all measured amplitudes.

Figure. 4.5.6 - 66. Vector jump from the function's point of view.

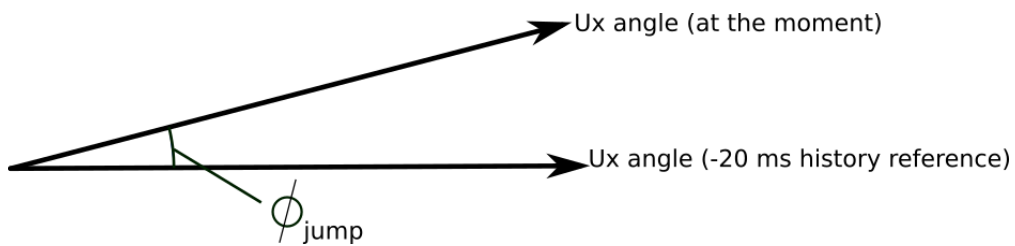

The following general settings define the general behavior of the function. These settings are static i.e. it is not possible to change them by editing the setting group.

Table. 4.5.6 - 130. General settings of the function.

Name	Range	Default	Description
$\Delta\alpha$ LN mode	<ul style="list-style-type: none"> <li>On</li> <li>Blocked</li> <li>Test</li> <li>Test/Blocked</li> <li>Off</li> </ul>	On	Set mode of VJP block. This parameter is visible only when <i>Allow setting of individual LN mode</i> is enabled in <i>General</i> menu.

Name	Range	Default	Description
$\Delta\alpha$ force status to	<ul style="list-style-type: none"> <li>Normal</li> <li>Blocked</li> <li>Trip</li> <li>Alarm</li> </ul>	Normal	Force the status of the function. Visible only when <i>Enable stage forcing</i> parameter is enabled in <i>General</i> menu.
Available stages	<ul style="list-style-type: none"> <li>Trip</li> <li>Trip and alarm</li> </ul>	Trip	Defines if alarm is included with trip or not.
Monitored voltages	<ul style="list-style-type: none"> <li>System all P-P Voltages</li> <li>System any P-P Voltage</li> <li>System L12 Voltage</li> <li>System L23 Voltage</li> <li>System L31 Voltage</li> <li>System all P-E voltages</li> <li>System any P-E voltage</li> <li>System L1 Voltage</li> <li>System L2 Voltage</li> <li>System L3 Voltage</li> <li>U4 Voltage</li> </ul>	System any P-P Voltage	Defines the monitored voltage channel(s)

Table. 4.5.6 - 131. Pick-up settings.

Name	Range	Step	Default	Description
Pick-up setting $\Delta\alpha$ (lead or lag) Trip	0.05...30.00°	0.01°	5°	Pick-up setting for trip signal
Pick-up setting $\Delta\alpha$ (lead or lag) Alarm	0.05...30.00°	0.01°	5°	Pick-up setting for alarm signal
Undervoltage block limit % < $U_n$	0.01...100.00% $U_n$	0.01% $U_n$	95% $U_n$	Block setting. When measured voltage is below this setting the function is blocked.

### Read-only parameters

The function's *Info* page displays useful, real-time information on the state of the protection function. It is accessed either through the device's HMI display, or through the setting tool software when it is connected to the device and its Live Edit mode is active.

Table. 4.5.6 - 132. Information displayed by the function.

Name	Range	Step	Description
$\Delta\alpha > LN$ behaviour	<ul style="list-style-type: none"> <li>On</li> <li>Blocked</li> <li>Test</li> <li>Test/Blocked</li> <li>Off</li> </ul>	-	Displays the mode of UEX block. This parameter is visible only when <i>Allow setting of individual LN mode</i> is enabled in <i>General</i> menu.
$\Delta\alpha > condition$	<ul style="list-style-type: none"> <li>Normal</li> <li>Blocked</li> <li>Trip</li> <li>Alarm</li> </ul>	-	Displays status of the protection function.
Voltage meas selected	<ul style="list-style-type: none"> <li>Selection Ok</li> <li>Selection not available</li> </ul>	-	Displays validity of the voltage channel(s) selected in "Monitored voltages" parameter.
$\Delta\alpha > U1$ Angle difference	-360...360deg	0.01deg	Displays the angle difference between present time and 20 ms ago.
$\Delta\alpha > U2$ Angle difference			
$\Delta\alpha > U3$ Angle difference			
$\Delta\alpha > U1$ meas/set	-360...360p.u.	0.01p.u.	Displays the ratio between the measured voltage and undervoltage block limit setting.
$\Delta\alpha > U2$ meas/set			
$\Delta\alpha > U3$ meas/set			

## Function blocking

The blocking signal is evaluated at the start of each program cycle. The blocking signals are connected to the function's dedicated input, which can be configured in the *IO* → *Blocking Input Control* tab of the function.

- When the pick-up element activates and the blocking signal is not active, a ALARM or TRIP signal is generated, and the function starts or continues with the trip time countdown.
- When the pick-up element activates and the blocking signal is active, a BLOCKED signal is generated, and the function does not process the event further.
- When an ALARM or TRIP signal is already active and the blocking input signal becomes active, the signal is reset and BLOCKED signal is generated. The release time characteristics are then processed in the same way as when the pick-up signal is reset.

The blocking signal needs to reach the device minimum of 5 ms before the set operating delay has passed in order for the blocking to activate in time.

## Events and registers

The vector jump function (abbreviated "VJP" in event block names) generates events and registers from the status changes in the events listed below. The user can select which event messages are stored in the main event buffer: ON, OFF, or both. The events triggered by the function are recorded with a time stamp.

The function's outputs can be used for direct I/O controlling and user logic programming. The function also provides a resettable cumulative counter for the ALARM, TRIP and BLOCKED events.

Table. 4.5.6 - 133. Event messages.

Event block name	Event names
VJP1	Block ON/OFF
VJP1	Trip ON/OFF
VJP1	Alarm ON/OFF

The function registers its operation into the last twelve (12) time-stamped registers. The register of the function records the ON event process data for ALARM, TRIP or BLOCKED. The table below presents the structure of the function's register content.

Table. 4.5.6 - 134. Register content.

Register	Description
Date and time	dd.mm.yyyy hh:mm:ss.mss
Event	Event name
Fault type	L1(2), L2(3), L3(1) and U4
Trip $\Delta\alpha$ meas / dataset	Trip angle difference
Alarm $\Delta\alpha$ meas / dataset	Alarm angle difference
Setting group in use	Setting group 1...8 active

### 4.5.7 Synchrocheck ( $\Delta V/\Delta a/\Delta f$ ; 25)

Checking the synchronization is important to ensure the safe closing of the circuit breaker between two systems. Closing the circuit breaker when the systems are not synchronized can cause several problems such as current surges which damage the interconnecting elements. The synchrocheck function has three stages: SYN1, SYN2 and SYN3. Their function and availability of these stages depend on which voltage channels are set to "SS" mode or not. Voltage measurement settings are located at *Measurements* → *Transformers* → *VT module*. When synchroswitching is used, the function automatically closes the breaker when both sides of the breaker are synchronized.

When only U3 or U4 voltage measurement channel has been set to "SS" mode:

- SYN1 – Supervises the synchronization condition between the channel set to "SS" mode and the selected system voltage (UL1, UL2, UL3, UL12, UL23 or UL31).
- SYN2 – Not active and not visible.
- SYN3 – Not active and not visible.

When both U3 and U4 have been set to "SS" mode:

- SYN1 – Supervises the synchronization condition between the U3 channel and the selected system voltage (UL12, UL23 or UL31).
- SYN2 – Supervises the synchronization condition between the U4 channel and the selected system voltage (UL12, UL23 or UL31).
- SYN3 – Supervises the synchronization condition between the channels U3 and U4.

The seven images below present three different example connections and four example applications of the synchrocheck function.

Figure. 4.5.7 - 67. Example connection of the synchrocheck function (3LN+U4 mode, SYN1 in use, UL1 as reference voltage).

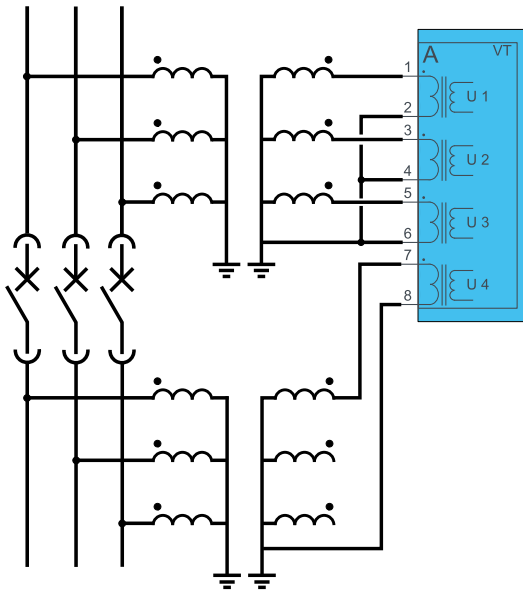

Figure. 4.5.7 - 68. Example connection of the synchrocheck function (2LL+U0+U4 mode, SYN1 in use, UL12 as reference voltage).

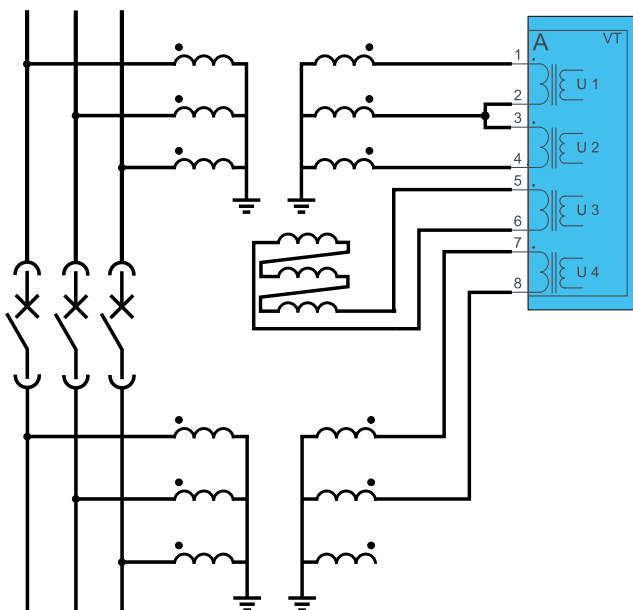

Figure. 4.5.7 - 69. Example connection of the synchrocheck function (2LL+U3+U4 mode, SYN3 in use, UL12 as reference voltage).

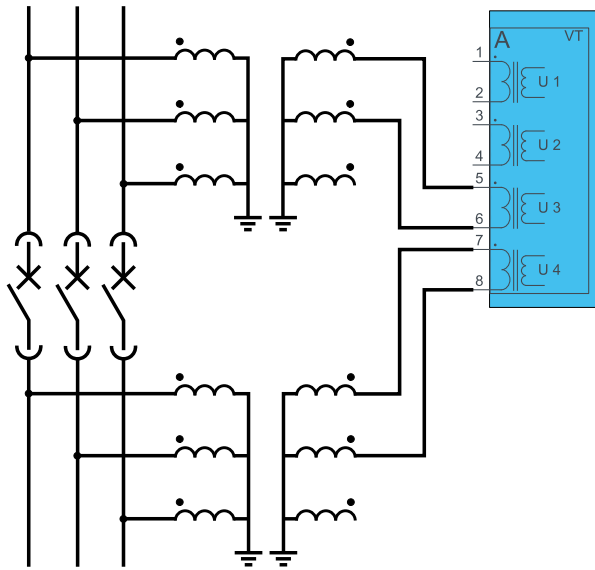

Figure. 4.5.7 - 70. Example application (synchrocheck over one breaker, with 3LL and 3LN VT connections).

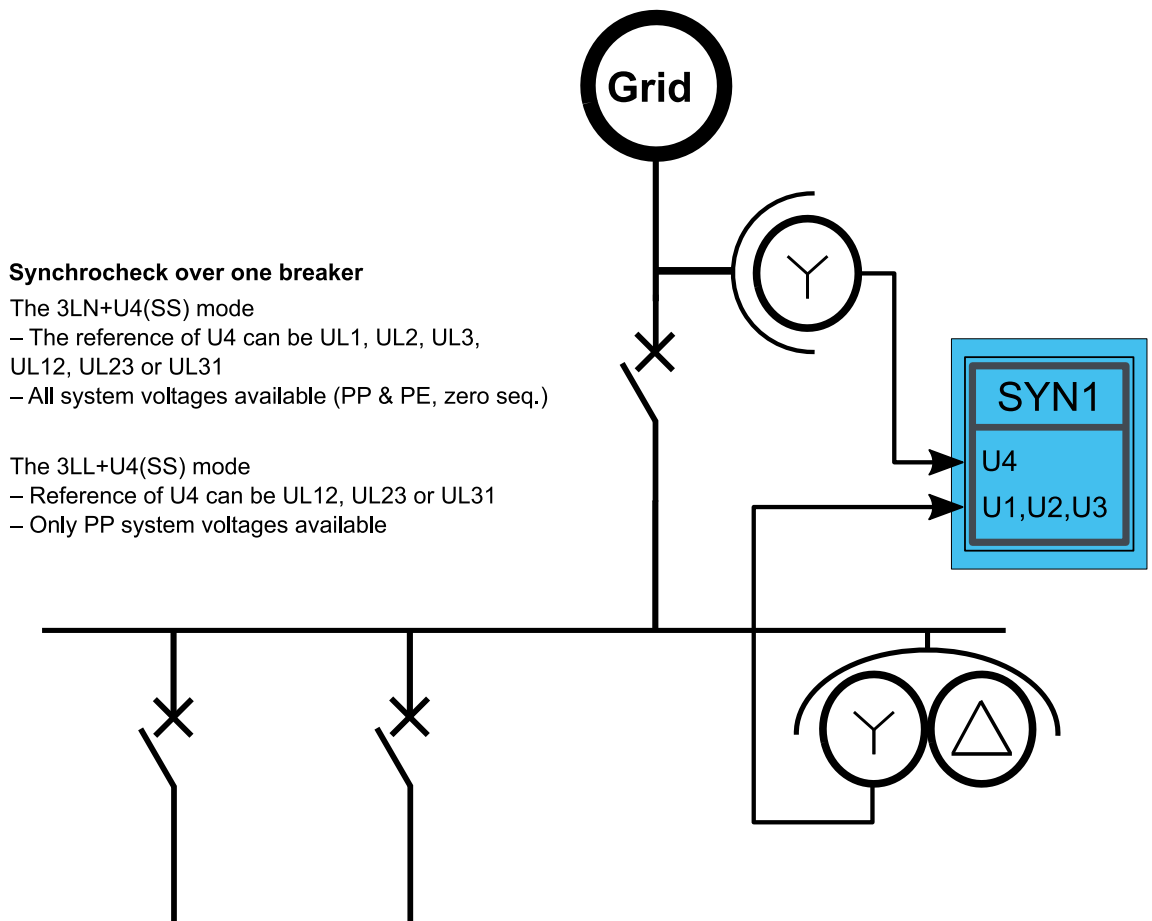

Figure. 4.5.7 - 71. Example application (synchrocheck over one breaker, with 2LL VT connection).

### Synchrocheck over one breaker

Mode 2LL+U3(U0)+U4(SS)

- Reference of U4 can be UL1, UL2, UL3, UL12, UL23 or UL31
- All system voltages available (PP & PE, zero seq.)

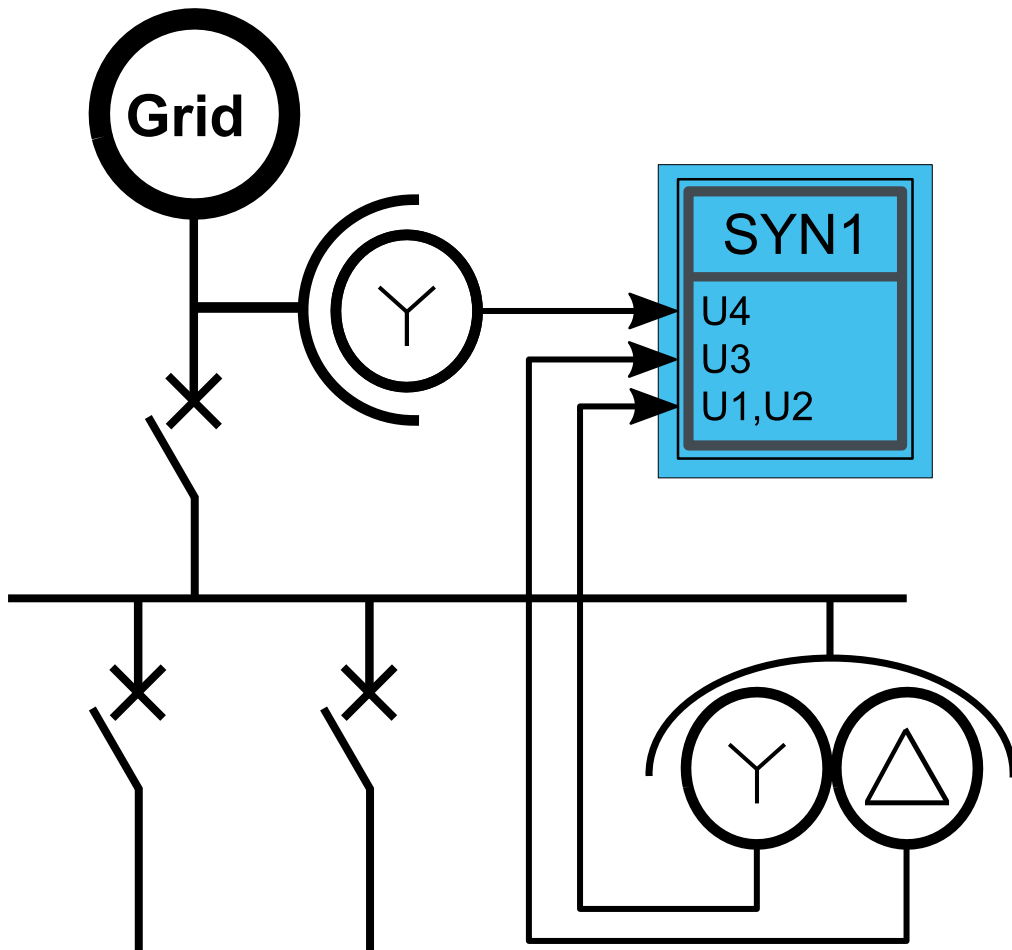

Figure. 4.5.7 - 72. Example application (synchrocheck over two breakers, with 2LL VT connection).

**Synchrocheck over two breakers**

Mode 2LL+U3(SS)+U4(SS)

- Reference of U3 and U4 can be UL12, UL23 or UL31
- PP system voltages available

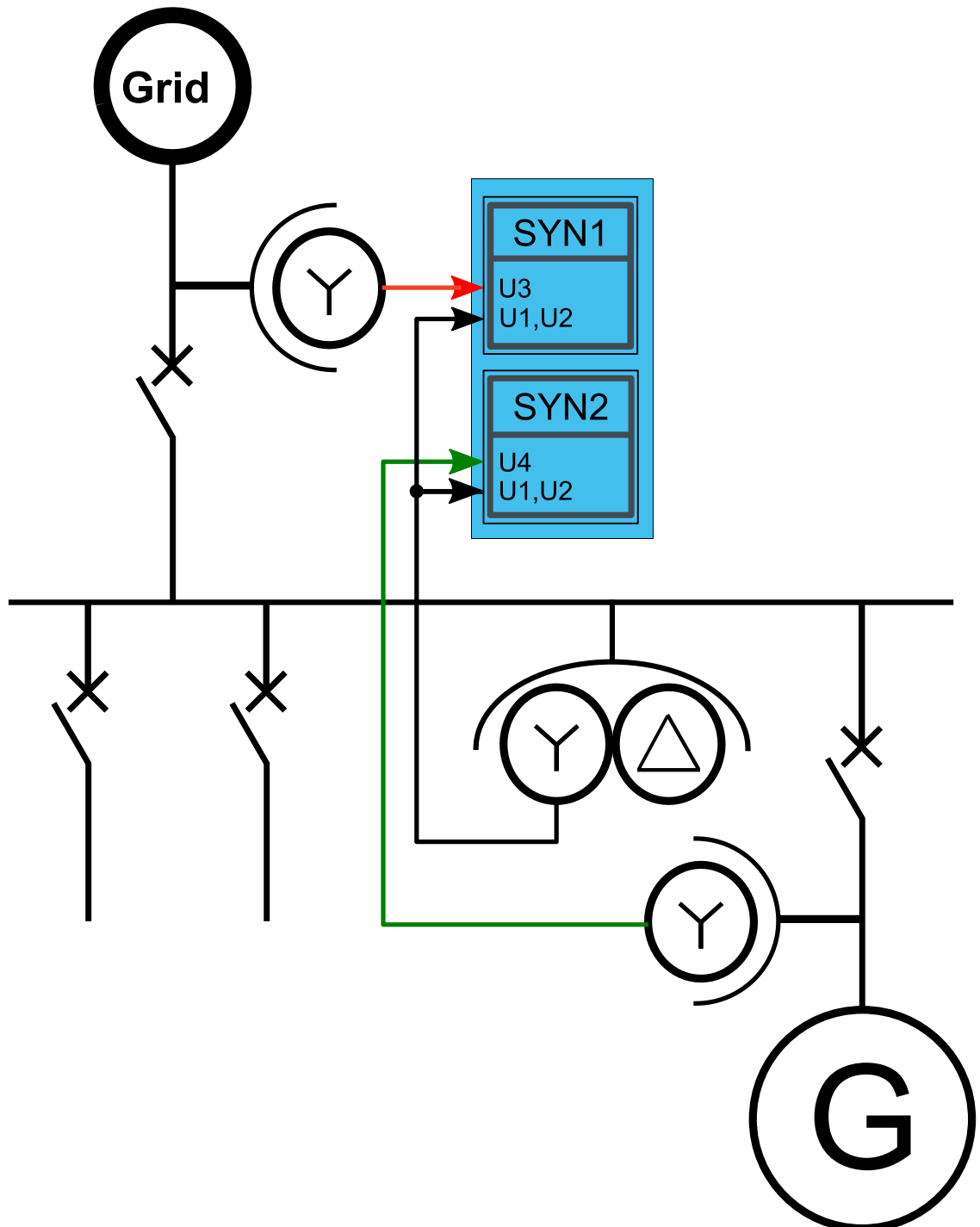
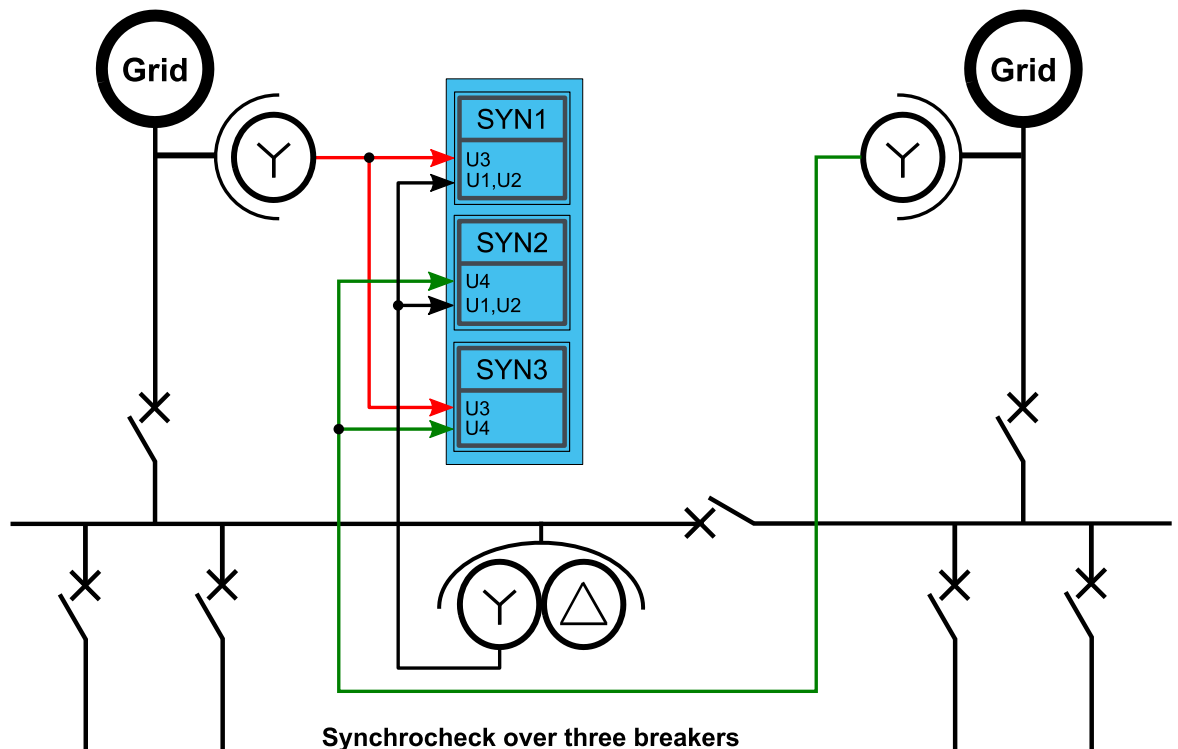

Figure. 4.5.7 - 73. Example application (synchrocheck over three breakers, with 2LL+U3+U4 connection).



**Synchrocheck over three breakers**

Mode 2LL+U3(SS)+U4(SS)

– Reference of U3 and U4 can be UL12, UL23 or UL31.

U3 and U4 References must be the same

– PP system voltages available



**NOTICE!**

When synchrocheck is used over three breakers, SYN1 and SYN2 must have the same reference voltage.

The following aspects of the compared voltages are used in synchrocheck:

- voltage magnitudes
- voltage frequencies
- voltage phase angles

The two systems are synchronized when these three aspects are matched. All three cannot, of course, ever be exactly the same so the function requires the user to set the maximum difference between the measured voltages.

Depending on how the measured voltage compares to the set  $U_{live}$  and  $U_{dead}$  parameters, either system can be in a "live" or a "dead" state. The parameter  $SYN_x U_{conditions}$  is used to determine the conditions (in addition to the three aspects) which are required for the systems to be considered synchronized.

The image below shows the different states the systems can be in.

Figure. 4.5.7 - 74. System states.

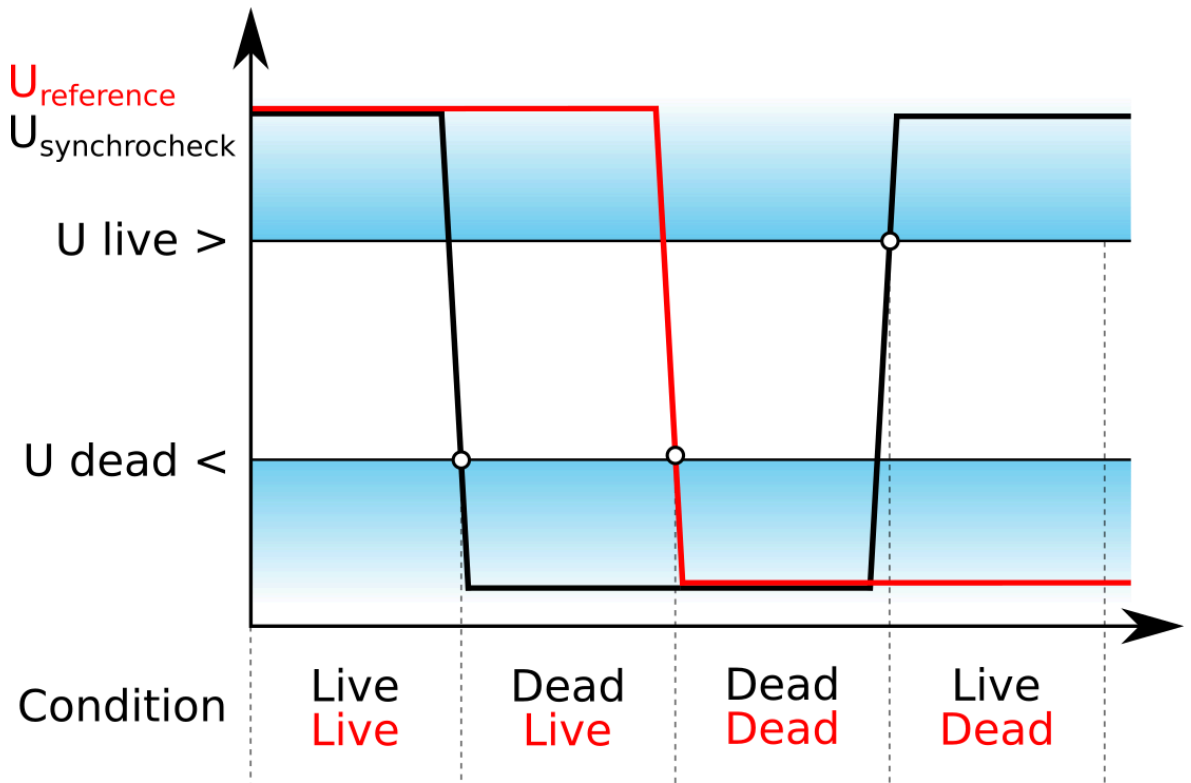

Figure. 4.5.7 - 75. Simplified function block diagram of the SYN1 and SYN2 function.

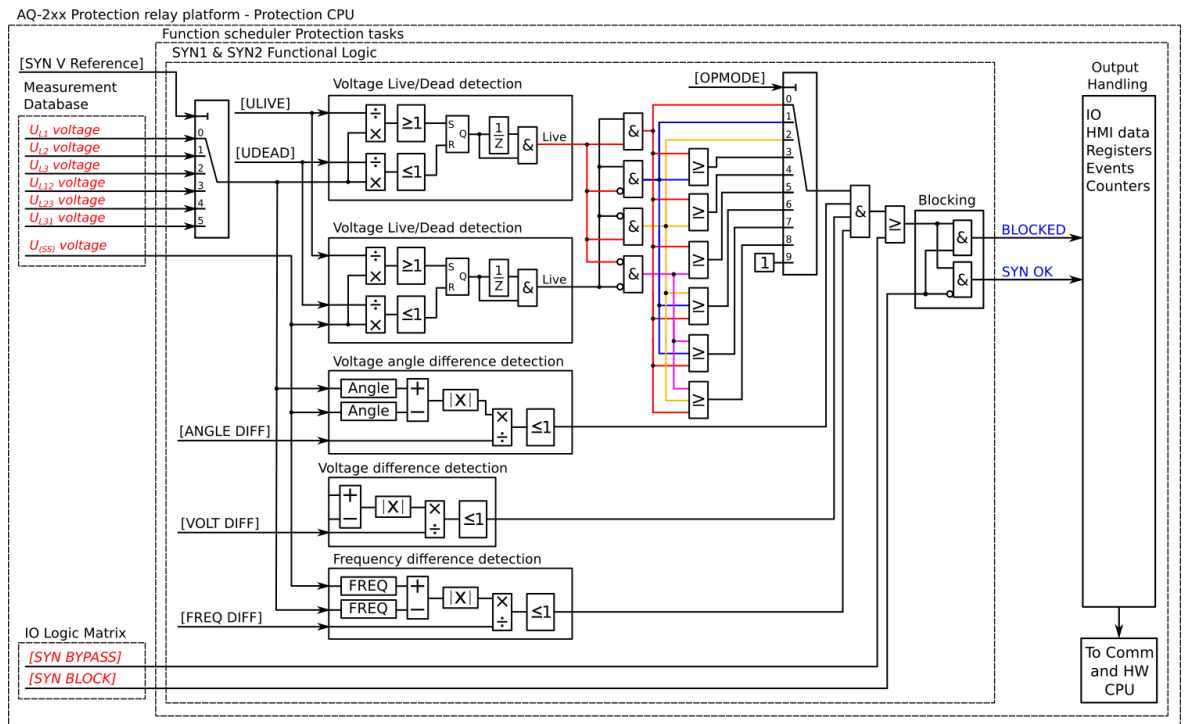
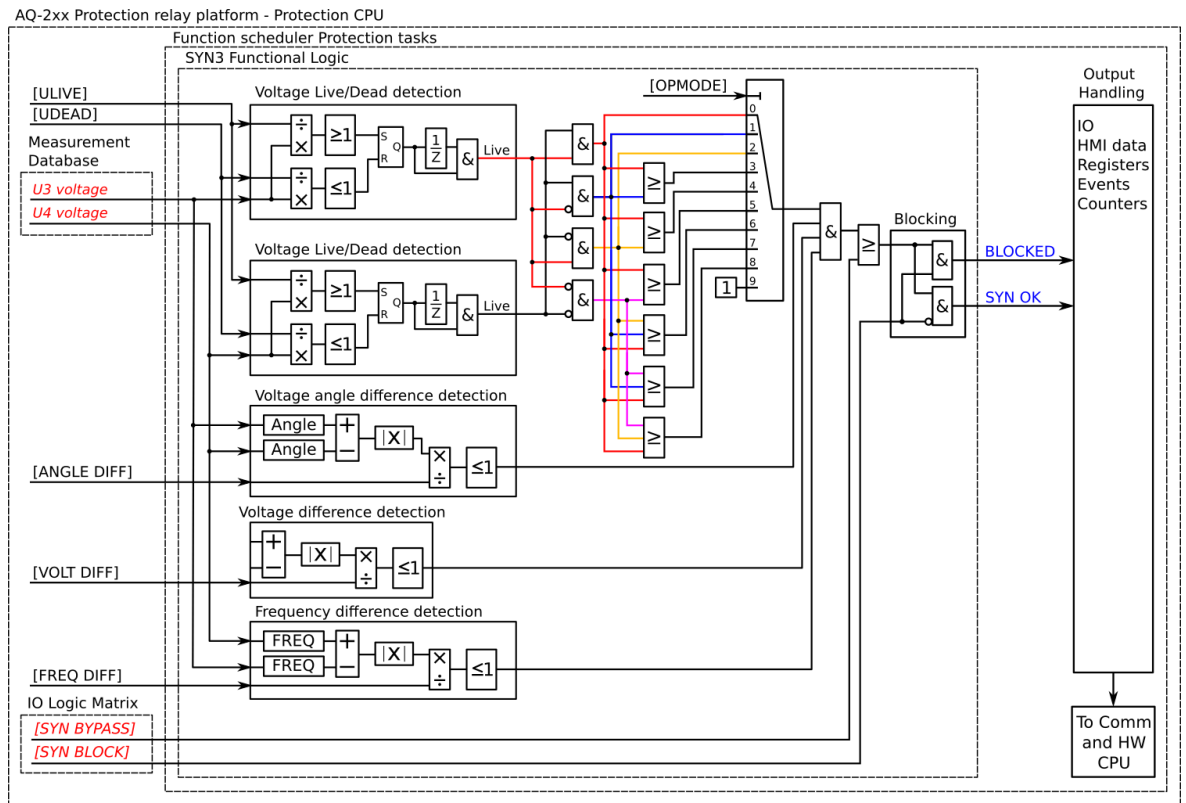

Figure. 4.5.7 - 76. Simplified function block diagram of the SYN3 function.



### Measured input

The function block uses user selected voltage channels. The function monitors frequency, angle and fundamental frequency component value of the selected channels.

Table. 4.5.7 - 135. Measurement inputs of the synchrocheck function.

Signal	Description
U <sub>1</sub> RMS	Fundamental frequency component of U <sub>1</sub> /V voltage channel
U <sub>2</sub> RMS	Fundamental frequency component of U <sub>2</sub> /V voltage channel
U <sub>3</sub> RMS	Fundamental frequency component of U <sub>3</sub> /V voltage channel
U <sub>4</sub> RMS	Fundamental frequency component of U <sub>4</sub> /V voltage channel

### Read-only parameters

The function's *Info* page displays useful, real-time information on the state of the protection function. It is accessed either through the device's HMI display, or through the setting tool software when it is connected to the device and its Live Edit mode is active.

Table. 4.5.7 - 136. Information displayed by the function.

Name	Range	Step	Description
dV / da / df LN behaviour	<ul style="list-style-type: none"> <li>• On</li> <li>• Blocked</li> <li>• Test</li> <li>• Test/Blocked</li> <li>• Off</li> </ul>	-	Displays the mode of SYN block. This parameter is visible only when <i>Allow setting of individual LN mode</i> is enabled in <i>General</i> menu.
SYN condition	<ul style="list-style-type: none"> <li>• SYN1 Blocked</li> <li>• SYN1 Ok</li> <li>• SYN1 Bypass</li> <li>• SYN1 Vcond Ok</li> <li>• SYN1 Vdiff Ok</li> <li>• SYN1 Adiff Ok</li> <li>• SYN1 fdiff Ok</li> </ul>	-	Displays status of the control function.
SYN volt status	<ul style="list-style-type: none"> <li>• Dead Dead</li> <li>• Live Dead</li> <li>• Dead Live</li> <li>• Live Live</li> <li>• Undefined</li> <li>• Not monitored</li> </ul>	-	Displays the voltage status of both sides.
SYN Mag diff	-120...120%Un	0.01%Un	Displays voltage difference between the two measured voltages.
SYN Ang diff	-360'...360deg	0.01deg	Displays angle difference between the two measured voltages.
SYN Freq diff	-75...75Hz	0.001Hz	Displays frequency difference between the two measured voltages.
SYN Switch status	<ul style="list-style-type: none"> <li>• Still</li> <li>• Departing</li> <li>• Enclosing</li> </ul>	-	Displays the synchroswitching status. This parameter is visible when "SYN Switching" parameter has been set to "Use SynSW".
Estimated BRK closing time	0...360s	0.005s	Estimated time left to breaker closing.
Networks rotating time	0...360s	0.005s	Estimated time how long it takes for the network to rotate fully.
Networks placement atm	-360...360deg	0.001deg	Networks placement in degrees.

### Function blocking

The block signal is checked in the beginning of each program cycle. The blocking signal is received from the blocking matrix in the function's dedicated input. If the blocking signal is not activated when the synchronization is OK, a SYN OK signal is generated.

If the blocking signal is active when the SYN OK activates, a BLOCKED signal is generated and the function does not process the situation further. If the SYN OK function has been activated before the blocking signal, it resets.

## Setting parameters

**NOTE!** Before these settings can be accessed, a voltage channel (U3 or U4) must be set into the synchrocheck mode ("SS") in the voltage transformer settings (*Measurements* → *VT Module*).

The general settings can be found at the synchrocheck function's *INFO* tab, while the synchrocheck stage settings can be found in the *Settings* tab (*Control* → *Control functions* → *Synchrocheck*).

Table. 4.5.7 - 137. General settings.

Name	Range	Step	Default	Description
dV / da / df LN mode	<ul style="list-style-type: none"> <li>On</li> <li>Blocked</li> <li>Test</li> <li>Test/Blocked</li> <li>Off</li> </ul>	-	On	Set mode of SYN block. This parameter is visible only when <i>Allow setting of individual LN mode</i> is enabled in <i>General</i> menu.
SYN(1,2,3) Status Force to	<ul style="list-style-type: none"> <li>Normal</li> <li>SYN1 Blocked</li> <li>SYN1 Ok</li> <li>SYN2 Blocked</li> <li>SYN2 Ok</li> <li>SYN3 Blocked</li> <li>SYN3 Ok</li> </ul>	-	Normal	Force the status of the function. Visible only when <i>Enable stage forcing</i> parameter is enabled in <i>General</i> menu.
System voltages are measured on	<ul style="list-style-type: none"> <li>Bus, Line is reference</li> <li>Line, Bus is reference</li> </ul>	-	Bus, Line is reference	Defines which voltage is the reference when determining dead/live status of voltages.
SYN OK signal behaviour	<ul style="list-style-type: none"> <li>Continuous</li> <li>Delayed continuous</li> <li>Delayed pulse</li> </ul>	-	Continuous	Defines the "SYN OK" signal behaviour. When set to "Delayed continuous" there is a user defined delay before the "SYN OK" signal is activated after synchronization is achieved. When set to "Delayed pulse" the "SYN OK" signal is deactivated after user defined delay.
SYN OK delay	0.000...1800.000 s	0.005 s	0.050 s	
SYN OK pulse length	0.000...1800.000 s	0.005 s	0.050 s	
Use SYNx	<ul style="list-style-type: none"> <li>No</li> <li>Yes</li> </ul>	-	No	Activated/de-activates the individual stages (SYN1, 2, and 3) of the synchrocheck function. Activating a stage reveals the parameter settings for the configuration.
SYNx Start check	<ul style="list-style-type: none"> <li>Always</li> <li>On start</li> </ul>	-	Always	Selects synchrocheck start behaviour. If "On start" is selected "SYNx START" input must be active for synchrochecking to begin. "SYNx START" input signal can be defined at <i>IO</i> → <i>Input control</i> menu. If "Always" is selected "SYNx START" input is not needed for synchrochecking to start.

Name	Range	Step	Default	Description
SYN1 V Reference	<ul style="list-style-type: none"> <li>Not in use</li> <li>UL12</li> <li>UL23</li> <li>UL31</li> <li>UL1</li> <li>UL2</li> <li>UL3</li> </ul>	-	Not in use	<p>Selects the reference voltage of the stage. Please note that the available references depend on the selected mode.</p> <p>All references available:</p> <ul style="list-style-type: none"> <li>- 3LN+U4(SS)</li> <li>- 2LL+U3(U0)+U4(SS)</li> <li>- 2LL+U3(SS)+U4(U0)</li> </ul> <p>Reference options 0...3 available:</p> <ul style="list-style-type: none"> <li>- 3LL+U4(SS)</li> <li>- 2LL+U3(Not in use)+U4(SS)</li> <li>- 2LL+U3(SS)+U4(Not in use)</li> </ul>
SYN2 V Reference	<ul style="list-style-type: none"> <li>Not in use</li> <li>UL12</li> <li>UL23</li> <li>UL31</li> </ul>	-	Not in use	Selects the reference voltage of the stage. SYN2 is available when both U3 and U4 have been set to SS mode.
SYN3 V Reference	<ul style="list-style-type: none"> <li>Not in use</li> <li>U3–U4</li> </ul>	-	Not in use	Enables and disables the SYN3 stage. Operable in the 2LL+U3+U4 mode, with references UL12, UL23 and UL31 can be connected to the channels.
SYNx Switching	<ul style="list-style-type: none"> <li>Not in use</li> <li>Use SynSW</li> </ul>	-	Not in use	Disables or enables synchroswitching. Synchroswitching is available only for SYN1. When synchroswitching is used, the function automatically closes the breaker when both sides of the breaker are synchronized. This setting is only visible when "Use SYN1" is activated.
SYNx Switch bk time	0.000...1800.000s	0.005s	0.05s	<p>Estimated time between a close command given to a breaker and the breaker entering the closed state. This setting is used to time the closing of the breaker so that both sides are as synchronized as possible when the breaker is actually closed.</p> <p>This setting is only visible when "SYN1 switching" is activated.</p>
SYNx Switching object	<ul style="list-style-type: none"> <li>Object 1</li> <li>Object 2</li> <li>Object 3</li> <li>Object 4</li> <li>Object 5</li> </ul>	-	Object 1	<p>When synchroswitching is enabled, this parameter defines which object receives the breaker's closing command.</p> <p>This setting is only visible when "SYNx Switching" is activated.</p>
Estimated BRK closing time	0.000...360.000s	0.005s	-	Displays the estimated time until networks are synchronized.
Networks rotating time	0.000...360.000s	0.005s	-	Displays the time it takes for both sides of the network to fully rotate.
Networks placement atm	-360.000...360.000deg	0.001deg	-	Indicates the angle difference between the two sides of the breaker at the moment.

Setting group selection controls the operating characteristics of the function, i.e. the user or user-defined logic can change function parameters while the function is running.

Table. 4.5.7 - 138. Synchrocheck stage settings.

Name	Range	Step	Default	Description
SYNx U conditions	<ul style="list-style-type: none"> <li>• LL only</li> <li>• LD only</li> <li>• DL only</li> <li>• LL &amp; LD</li> <li>• LL &amp; DL</li> <li>• LL &amp; DD</li> <li>• LL &amp; LD &amp; DL</li> <li>• LL &amp; LD &amp; DD</li> <li>• LL &amp; DL &amp; DD</li> <li>• Bypass</li> </ul>	-	LL only	Determines the allowed states of the supervised systems. L = Live D = Dead
SYNx U live >	0.10...100.00%Un	0.01%Un	20%Un	The voltage limit of the live state.
SYNx U dead <	0.00...100.00%Un	0.01%Un	20%Un	The voltage limit of the dead state. Not in use when set to 0%Un
SYNx U diff <	2.00...50.00%Un	0.01%Un	2.00%Un	The maximum allowed voltage difference between the systems.
SYNx angle diff <	3.00...90.00deg	0.01deg	3deg	The maximum allowed angle difference between the systems.
SYNx freq diff <	0.05...0.50Hz	0.01Hz	0.1Hz	The maximum allowed frequency difference between the systems.

## Events and registers

The synchrocheck function (abbreviated "SYN" in event block names) generates events and registers from the status changes in the events listed below. The user can select which event messages are stored in the main event buffer: ON, OFF, or both. The events triggered by the function are recorded with a time stamp.

The function's outputs can be used for direct I/O controlling and user logic programming.

The function offers three (3) independent stages; the events are segregated for each stage operation.

Table. 4.5.7 - 139. Event messages.

Event block name	Event names
SYN1	SYN1 Blocked ON/OFF
SYN1	SYN1 Ok ON/OFF
SYN1	SYN1 Bypass ON/OFF
SYN1	SYN1 Volt condition OK
SYN1	SYN1 Volt cond not match
SYN1	SYN1 Volt diff Ok
SYN1	SYN1 Volt diff out of setting
SYN1	SYN1 Angle diff Ok

Event block name	Event names
SYN1	SYN1 Angle diff out of setting
SYN1	SYN1 Frequency diff Ok
SYN1	SYN1 Frequency diff out of setting
SYNX1	SYN1 Voltage difference Ok ON/OFF
SYNX1	SYN1 Angle difference Ok ON/OFF
SYNX1	SYN1 Frequency difference Ok ON/OFF
SYNX1	SYN1 Live Live Condition ON/OFF
SYNX1	SYN1 Live Dead Condition ON/OFF
SYNX1	SYN1 Dead Live Condition ON/OFF
SYNX1	SYN1 Dead Dead Condition ON/OFF
SYNX1	SYN1 Voltage Difference too high Vbus > Vline ON/OFF
SYNX1	SYN1 Voltage Difference too high Vline > Vbus ON/OFF
SYNX1	SYN1 Frequency Difference too high fbus > fline ON/OFF
SYNX1	SYN1 Frequency Difference too high fline > fbus ON/OFF
SYNX1	SYN1 Angle Difference too high a bus leads a line ON/OFF
SYNX1	SYN1 Angle Difference too high a line leads a bus ON/OFF
SYNX1	SYN1 Bus voltage Live ON/OFF
SYNX1	SYN1 Bus voltage Dead ON/OFF
SYNX1	SYN1 Line voltage Live ON/OFF
SYNX1	SYN1 Line voltage Dead ON/OFF

The function registers its operation into the last twelve (12) time-stamped registers. The table below presents the structure of the function's register content.

Table. 4.5.7 - 140. Register content.

Name	Range
Date and time	dd.mm.yyyy hh:mm:ss.mss
Event	Event name
SYNx Ref1 voltage	The reference voltage of the selected stage.
SYNx Ref2 voltage	The reference voltage of the selected stage.
SYNx Volt Cond	The voltage condition of the selected stage.
SYNx Volt status	The voltage status of the selected stage.

Name	Range
SYNx Vdiff	The voltage difference of the selected stage.
SYNx Vdiff cond	The set condition of the voltage difference of the selected stage.
SYNx Adiff	The angle difference of the selected stage.
SYNx Adiff cond	The set condition of the angle difference of the selected stage.
SYNx fdiff	The frequency difference of the selected stage.
SYNx fdiff cond	The set condition of the frequency difference of the selected stage.
Setting group in use	Setting group 1...8 active.

### 4.5.8 Synchronizer ( $\Delta V/\Delta a/\Delta f$ ; 25)

The synchronizer function is used to automatically synchronize generators to power grids. Proper synchronizing is essential to avoid inrush currents, power system oscillations as well as thermal and mechanical stress on the generator when connecting a synchronous generator to a grid.

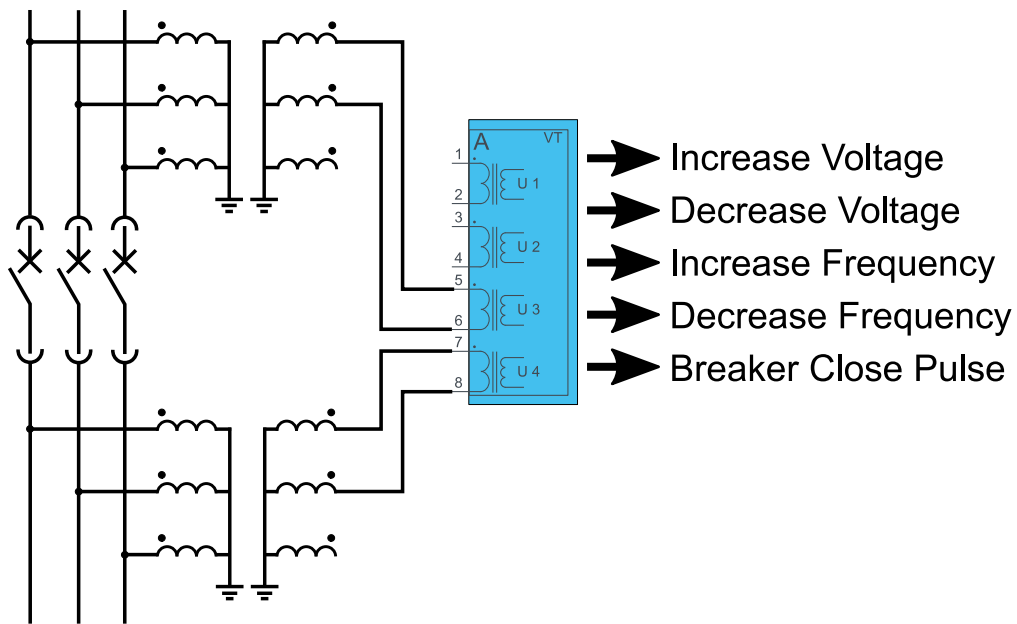
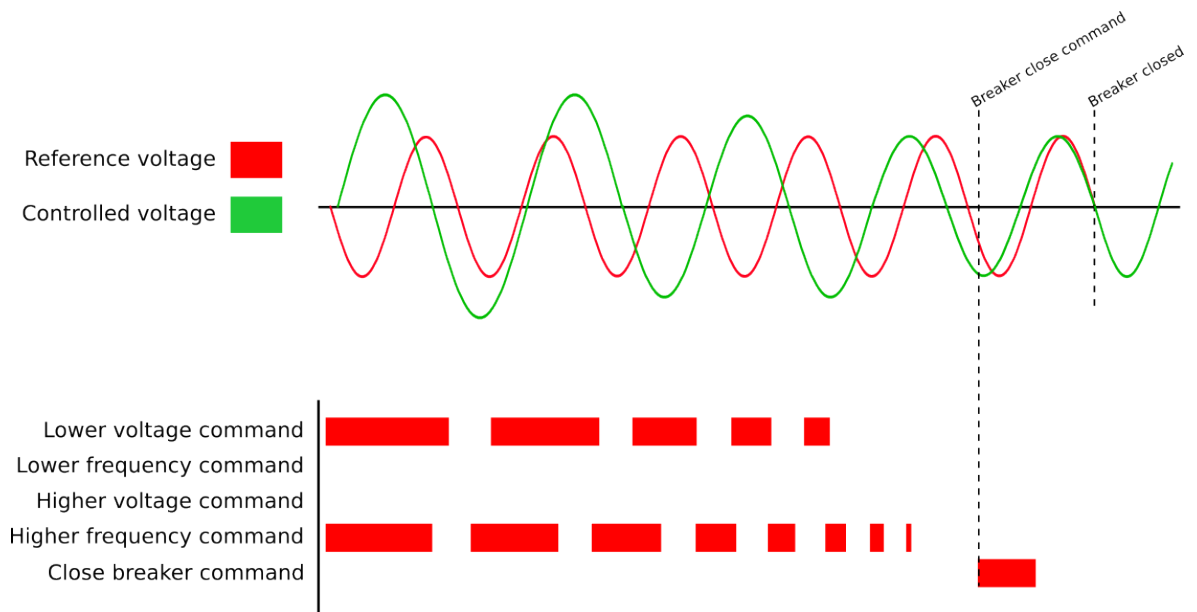

Figure. 4.5.8 - 77. Simplified presentation of synchronizer operation



The synchronizing function uses voltage signals from each side of the circuit breaker to be closed.

- The amplitude difference between the two voltages is used to send "Increase" and "Decrease" commands to the generator's voltage regulator. The pulse length for these commands can be set, and it is automatically adjusted depending on the difference between the two measured signals.
- The frequency difference between the two voltages (the slip frequency) is used to send "Increase" and "Decrease" commands to the turbine's speed governor. The pulse length for these commands can be adjusted individually to take into account turbine governors with different speeds. The pulse length is automatically adjusted depending on the difference between the two measured signals.
- Settings can be adjusted to only allow positive slip to avoid reverse power at synchronizing.
- When the amplitude, the speed, and the phase-angle between the two voltages match (within pre-set limits), a "Close" command signal is sent to the generator's circuit breaker.

Pre-closing time can be used to allow for delay time in a circuit breaker and any auxiliary relays. The pre-closing angle is adjusted automatically depending on the slip frequency.

The outputs of the function are the following signals:

- Voltage Magnitude Difference Ok
- Voltage Frequency Difference Ok
- Voltage Angle Difference Ok
- Blocked
- Running
- Increase Voltage
- Decrease Voltage
- Increase Frequency
- Decrease Frequency
- Breaker Close Pulse
- Long Sync Time
- Nets Standstill
- Nets Departing
- Nets Enclosing

The inputs of the function are the following signals:

- Start synchronizer
- Stop synchronizer
- DeadBus synchronizing
- BlackStart synchronizing
- Block and interrupt synchronizing
- Breaker closed
- Open synchronizer HMI
- Manual increase voltage
- Manual decrease voltage
- Manual increase frequency
- Manual decrease frequency
- Manual close breaker

## Measured input

The function block uses user selected voltage channels. The function monitors frequency, angle and fundamental frequency component value of the selected channels.

Table. 4.5.8 - 141. Measurement inputs of the synchronizer function.

Signal	Description
U <sub>1</sub> RMS	Fundamental frequency component of U <sub>1</sub> /V voltage
U <sub>2</sub> RMS	Fundamental frequency component of U <sub>2</sub> /V voltage
U <sub>3</sub> RMS	Fundamental frequency component of U <sub>3</sub> /V voltage
U <sub>4</sub> RMS	Fundamental frequency component of U <sub>4</sub> /V voltage

## Setting and indication parameters

Table. 4.5.8 - 142. General setting and status indication parameters.

Name	Range	Step	Default	Description
Synchronizing by	<ul style="list-style-type: none"> <li>• System voltages to U3/U4 input</li> <li>• Between U3/U4 input</li> </ul>	-	System voltages to U3/U4 input	Determines if the voltages are synchronized between one of the system voltages and either U3 or U4 channel or if the voltage is synchronized between U3 and U4 channel. Visible if both U3 and U4 channel have been set to "SS" mode in <i>Measurement</i> → <i>VT Module (4U)</i> menu.
Synchronizer reference voltage input	<ul style="list-style-type: none"> <li>• U3 input</li> <li>• U4 input</li> </ul>	-	U4 input	Determines the reference voltage. Visible if both U3 and U4 voltage channels have been set to "SS" mode in <i>Measurement</i> → <i>VT Module (4U)</i> menu.

Name	Range	Step	Default	Description
Voltage difference calculation mode	<ul style="list-style-type: none"> <li>System is reference</li> <li>U3/U4 input is reference</li> </ul>	-	System is reference	Determines if the voltage channel that has been set to "SS" mode (U3 or U4) is the reference or if one of the phase-to-phase or phase-to-neutral voltages (UL1, UL2, UL3, UL12, UL23, UL31) is the reference.
Synchronizer voltage reference	<ul style="list-style-type: none"> <li>UL12</li> <li>UL23</li> <li>UL31</li> <li>UL1</li> <li>UL2</li> <li>UL3</li> </ul>	-	UL12	Determines reference voltage. Visible if "Synchronizing by" has been set to "System voltages to U3/U4".
Synchronizer measurement settings	<ul style="list-style-type: none"> <li>Meas.Conf.Incorrect</li> <li>PP and PE voltages</li> <li>PP Voltages</li> </ul>	-	-	Displays used voltage: phase-to-phase voltages, phase-to-earth voltages or incorrect settings.
Synchronizer status	<ul style="list-style-type: none"> <li>Conf.Error</li> <li>Idle Ready</li> <li>Synchronizing</li> <li>Blocked</li> </ul>	-	-	Displays the status of the function.
Synchronizing by	<ul style="list-style-type: none"> <li>Autosynchronizer</li> <li>Manual commands</li> </ul>	-	Autosynchronizer	When set to "Manual commands" synchronizer allows manual commands given to "Manual increase voltage", "Manual decrease voltage", "Manual increase frequency" and "Manual decrease frequency" inputs.
Manual switching mode	<ul style="list-style-type: none"> <li>Assisted synchroswitch</li> <li>I know what I am doing</li> </ul>	-	Assisted synchroswitch	Visible if "Synchronizing by" has been set to "Manual commands"
Synchroswitch status	<ul style="list-style-type: none"> <li>Standstill</li> <li>Departing</li> <li>Enclosing</li> </ul>	-	-	Displays the status of synchroswitch.
Force control signals on	<ul style="list-style-type: none"> <li>None</li> <li>Blocked On</li> <li>Running On</li> <li>Increase U On</li> <li>Decrease U On</li> <li>Increase F On</li> <li>Decrease F On</li> <li>CB Close On</li> <li>LongSyncTime On</li> </ul>	-	None	Visible when "Enable stage forcing" is enabled in "General" menu. Bypasses functions internal logic and forces control signals.
Enable on-screen synchronizer view	<ul style="list-style-type: none"> <li>Disabled</li> <li>Enabled</li> </ul>	-	Disabled	Enables synchronizer view in HMI.
Magnitude difference	-200.000...200.000%Un	0.001%Un	0%Un	Voltage magnitude difference between the two measured voltages.

Name	Range	Step	Default	Description
Frequency difference	-100.000...100.000Hz	0.001Hz	0Hz	Frequency difference between the two measured voltages.
Angle difference	-360.000...360.000deg	0.001deg	0deg	Angle difference between the two measured voltages.
Magnitude difference on closing BRK	-200.000...200.000%Un	0.001%Un	0%Un	Recorded difference on magnitude when breaker was closed.
Frequency difference on closing BRK	-100.000...100.000Hz	0.001Hz	0Hz	Recorded difference on frequency when breaker was closed.
Angle difference on closing BRK	-360.000...360.000deg	0.001deg	0deg	Recorded difference on angle when breaker was closed.
Estimated BRK Closing time	0.000...360.000s	0.005s	0s	Estimated time left to breaker closing.
Networks rotating time	0.000...360.000s	0.005s	0s	Estimated time how long it takes for the network to rotate fully.
Networks placement atm	-360.000...360.000deg	0.001deg	0deg	Networks placement in degrees.
Synchronizing time left	0.000...1800.000s	0.005s	0s	Time left for synchronizing from the start of synchronizing command given.
Get measurement errors for fine tuning	- Get errors	-	-	When in synchronized state, it is possible to read measurement error with this parameter.
Magnitude difference fine tune	-200.000...200.000%	0.001%	0%	Shows magnitude difference when "Get errors" command has been given. This value can then be set to "Adjustment for measurement inaccuracy or set of desired volt. Offset" to fine tune measurement.
Frequency difference fine tune	-100.000...100.000Hz	0.001Hz	0Hz	Shows frequency difference when "Get errors" command has been given. This value can then be set to "Adjustment for measurement inaccuracy or set of desired freq. offset" to fine tune measurement.
Angle difference fine tune	-360.000...360.000deg	0.001deg	0deg	Shows frequency difference when "Get errors" command has been given. This value can then be set to "Adjustment for measurement inaccuracy or set of desired angular offset" to fine tune measurement.

Table. 4.5.8 - 143. Synchronizing settings.

Name	Range	Step	Default	Description
Minimum voltage allowed for synchronizing	0.00...105.00 %Un	0.01 %Un	80.00 %Un	If the measured voltages are below this value, synchronizing is not allowed.
Maximum voltage allowed for synchronizing	0.00...200.00 %Un	0.01 %Un	120.00 %Un	If the measured voltages are above this value, synchronizing is not allowed.
Maximum zero voltage allowed for synchronizing (100% disabled)	0.00...100.00 %Un	0.01 %Un	5.00 %Un	If the measured zero sequence voltage is above this value, synchronizing is not allowed. If set to 100% this parameter is disabled.
Maximum allowed voltage difference	0.10...50.00%Un	0.01%Un	2.00%Un	If voltage difference between the two measured voltages are higher than determined here, synchronizing is not allowed.
Maximum allowed overfrequency difference to allow synchronizing	0.00...2.00Hz	0.01Hz	0.2Hz	If overfrequency exceeds value determined here, synchronizing is not allowed.
Maximum allowed underfrequency difference to allow synchronizing	0.00...2.00Hz	0.01Hz	0Hz	If underfrequency exceeds value determined here, synchronizing is not allowed.
Maximum time for synchronizing	0.000...1800.000s	0.005s	300.000s	If synchronizing takes longer than the value determined here, synchronizing will be cancelled.
Maximum allowed angular disposition to allow synchronizing	-25.00...25.00deg	0.01deg	10.00deg	If angle difference between the two measured voltages exceeds the value determined here, synchronizing is not allowed.
Adjustment for measurement inaccuracy or set of desired volt. offset	-95.0000...95.0000%Un	0.0001%Un	0%Un	If voltage magnitude difference is measured even in perfectly synchronized state, this parameter can be used for fine tuning the measurement. Value suggested by "Magnitude difference fine tune" can be used.
Adjustment for measurement inaccuracy or set of desired angular offset	-60.0000...60.0000deg	0.0001deg	0deg	If frequency difference is measured even in perfectly synchronized state, this parameter can be used for fine tuning the measurement. Value recommended by "Angle difference fine tune" can be used.

Name	Range	Step	Default	Description
Adjustment for measurement inaccuracy or set of desired freq. offset	-0.5000...2.0000Hz	0.0001Hz	-0.1000Hz	If angle difference is measured even in perfectly synchronized state, this parameter can be used for fine tuning the measurement. Value suggested by "Frequency difference fine tune" can be used.
Voltage adjustment slope	0.00...25.00%/s	0.01%/s	0.20%/s	Speed of voltage adjustment. Lower value is slower and higher is faster. Depends on used excitation device and its settings.
Volt. Max. adjustment pulse length	0.000...1800.000s	0.005s	3.000s	Maximum time voltage adjustment pulse is allowed to be active.
Volt. Min. adjustment pulse length	0.000...1800.000s	0.005s	0.100s	Minimum time voltage adjustment pulse is allowed to be active.
Volt. Min. Resting time between pulses	0.000...1800.000s	0.005s	2.500s	Minimum time between each voltage adjustment pulse.
Freq. Max. adjustment pulse length	0.000...1800.000s	0.005s	3.000s	Maximum time frequency adjustment pulse is allowed to be active.
Freq. Min. adjustment pulse length	0.000...1800.000s	0.005s	0.100s	Minimum time frequency adjustment pulse is allowed to be active.
Freq. Min. Resting time between pulses	0.000...1800.000s	0.005s	2.500s	Minimum time between each frequency adjustment pulse.
Frequency adjustment slope when increasing	0.00...10.00Hz/s	0.01Hz/s	0.10Hz/s	Determines how many Hz per second frequency increases with frequency increasing command.
Frequency adjustment slope when decreasing	-10.00...0.00Hz/s	0.01Hz/s	-0.10Hz/s	Determines how many Hz per second frequency decreases with frequency decreasing command.
Circuit breaker pre-closing time incl auxiliary relays	0.000...1800.000s	0.005s	0.100s	Estimated delay from close signal initiation to breaker actually reaching full closed state including aux contacts.
Lenght of circuit breaker closing pulse	0.000...1800.000s	0.005s	0.250s	Breaker close pulse lenght.
Multiple On pulses	<ul style="list-style-type: none"> <li>• Single On pulse</li> <li>• Multiple pulses</li> </ul>	-	Single On pulse	Selection whether the synchronizer tries to synchronize and close breaker for the full given maximum time with multiple tries or in case if the first attempt fails also synchronizing sequence is disrupted.

Table. 4.5.8 - 144. Synchronizer internal parameters.

Name	Range	Step	Default	Description
Maximum allowed voltage difference to start synchronizing	0.00...50.00%Un	0.01%Un	20.00%Un	Maximum voltage difference on sides of the synchronizing breaker. If the difference is too high, synchronizing sequence is not starting.
Block voltage up commands over	0.00...50.00%Un	0.01%Un	20.00%Un	Blocking of the controlled side voltage maximum value.
Block voltage down commands under	-50.00...50.00%Un	0.01%Un	-20.00%Un	Blocking of the controlled side voltage minimum value.
Integrator sum when voltage adjustment pulse is generated	0.00...50.00%	0.01%	10.00%	Controls the given raise/lower pulse rate for the voltage control pulses. Lower value gives pulses more frequently. Setting depends on the used voltage regulator and its settings.
Voltage adjustment pulse length constant	0.00...5000.00	0.01	1000.00	Base value for voltage pulse length.
Maximum allowed frequency difference to start synchronizing	0.00...25.00Hz	0.01Hz	5.00Hz	Maximum frequency difference on sides of the synchronizing breaker.
Integrator sum when frequency adjustment pulse is generated	0.00...50.00Hz	0.01Hz	1.00Hz	Controls the given raise/lower pulse rate for the frequency control pulses. Lower value gives pulses more frequently. Setting depends on the used application and its properties.
Frequency adjustment pulse length constant	0.00...5000.00	0.01	1000.00	Base value for frequency pulse length.
Filter time for angle derivative	0.000...1800.000s	0.005s	1.000s	Angle estimation fine tuning, higher value gives more accurate result but may lead to longer synchronizing total time.
Circuit breaker pre-closing adjustment constant	0.00...10.00	0.01	0.10	Fine tuning of the synchroswitch function for the breaker close command.

## Function blocking

The block signal is checked in the beginning of each program cycle. The blocking signal is received from the blocking matrix in the function's dedicated input. If the blocking signal is not activated when the pick-up element activates, a BREAKER CLOSE PULSE signal is generated and the function proceeds to the time characteristics calculation.

If the blocking signal is active when the pick-up element activates, a BLOCKED signal is generated and the function does not process the situation further.

The variables the user can set are binary signals from the system. The blocking signal needs to reach the device minimum of 5 ms before the set operating delay has passed in order for the blocking to activate in time.

## Events

The synchronizing function (abbreviated "GSYN" in event block names) generates events and registers from the status changes in the events listed below. The user can select which event messages are stored in the main event buffer: ON, OFF, or both. The events triggered by the function are recorded with a time stamp.

The function's output signals can be used for direct I/O controlling and user logic programming.

Table. 4.5.8 - 145. Event messages.

Event block name	Event names
GSYN	Synchronizing Blocked ON/OFF
GSYN	Synchronizing Running ON/OFF
GSYN	Synchr. Increase Voltage ON/OFF
GSYN	Synchr. Decrease Voltage ON/OFF
GSYN	Synchr. Increase Frequency ON/OFF
GSYN	Synchr. Decrease Frequency ON/OFF
GSYN	Synchronizer BRK Close ON/OFF
GSYN	Synchronizer Long Sync. Time ON/OFF
GSYN	Synchroswitch Close fail Re-init ON/OFF
GSYN	Synchroswitching requested ON/OFF
GSYN	Voltage Mag.Difference Ok/Not Ok
GSYN	Voltage Freq.Difference Ok/Not Ok
GSYN	Voltage Ang.Difference Ok/Not Ok
GSYN	Nets Standstill ON/OFF
GSYN	Nets Departing ON/OFF
GSYN	Nets Enclosing ON/OFF

### 4.5.9 Milliampere output control

The milliamp current loop is the prevailing process control signal in many industries. It is an ideal method of transferring process information because a current does not change as it travels from a transmitter to a receiver. It is also much more simple and cost-effective.

The benefits of 4...20 mA loops:

- the dominant standard in many industries
- the simplest option to connect and configure
- uses less wiring and connections than other signals, thus greatly reducing initial setup costs
- good for travelling long distances, as current does not degrade over long connections like voltage does
- less sensitive to background electrical noise

- detects a fault in the system incredibly easily since 4 mA is equal to 0 % output.

## Milliampere (mA) outputs

The device supports up to two (2) independent mA option cards. Each card has four (4) mA output channels and one (1) mA input channel. If the device has an mA option card, enable mA outputs at *Control* → *Device IO* → *mA outputs*. The outputs are activated in groups of two: channels 1 and 2 are activated together, as are channels 3 and 4.

Table. 4.5.9 - 146. Main settings (output channels).

Name		Range	Default	Description
mA option card 1	Enable mA output channels 1 and 2	<ul style="list-style-type: none"> <li>• Disabled</li> <li>• Enabled</li> </ul>	Disabled	Enables and disables the outputs of the mA output card 1.
	Enable mA output channels 3 and 4			
mA option card 2	Enable mA output channels 5 and 6	<ul style="list-style-type: none"> <li>• Disabled</li> <li>• Enabled</li> </ul>	Disabled	Enables and disables the outputs of the mA output card 2.
	Enable mA output channels 7 and 8			

Table. 4.5.9 - 147. Settings for mA output channels.

Name	Range	Step	Default	Description
Enable mA output channel	<ul style="list-style-type: none"> <li>• Disabled</li> <li>• Enabled</li> </ul>	-	Disabled	Enables and disables the selected mA output channel. If the channel is disabled, the channel settings are hidden.
Magnitude selection for mA output channel	<ul style="list-style-type: none"> <li>• Currents</li> <li>• Voltages</li> <li>• Powers</li> <li>• Impedance and admittance</li> <li>• Other</li> </ul>	-	Currents	Defines the measurement category that is used for mA output control.
Magnitude of mA output channel	(dependent on the measurement category selection)	-	(dependent on the measurement category selection)	Defines the measurement magnitude used for mA output control. The available measurements depend on the selection of the "Magnitude selection for mA output channel" parameter.
Input value 1	$-10^7 \dots 10^7$	0.001	0	The first input point in the mA output control curve.
Scaled mA output value 1	0.0000...24.0000mA	0.0001mA	0mA	The mA output value when the measured value is equal to or less than Input value 1.
Input value 2	$-10^7 \dots 10^7$	0.001	1	The second input point in the mA output control curve.
Scaled mA output value 2	0.0000...24.0000mA	0.0001mA	0mA	The mA output value when the measured value is equal to or greater than Input value 2.

Figure. 4.5.9 - 78. Example of the effects of mA output channel settings.

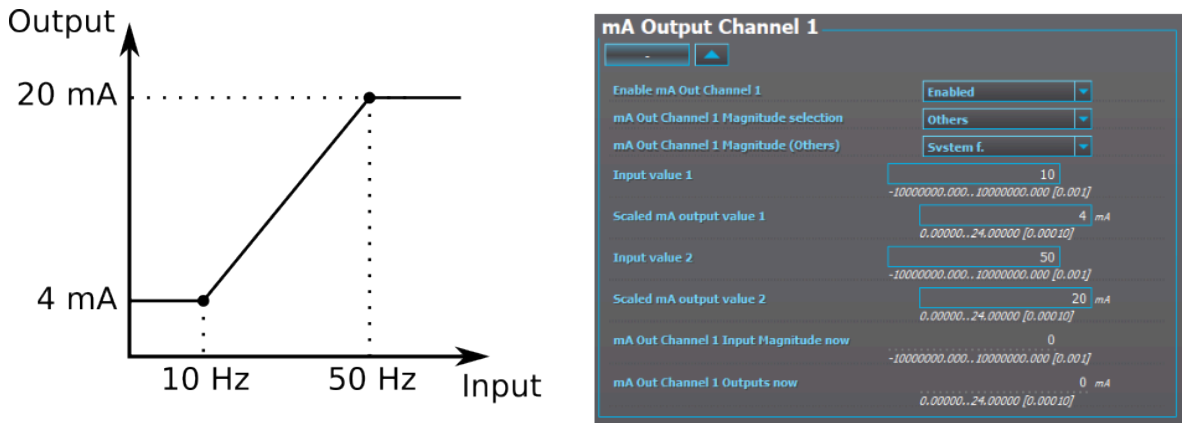

Table. 4.5.9 - 148. Hardware indications.

Name	Range	Description
Hardware in mA output channels 1...4	<ul style="list-style-type: none"> <li>• None</li> <li>• Slot A</li> <li>• Slot B</li> <li>• Slot C</li> <li>• Slot D</li> <li>• Slot E</li> <li>• Slot F</li> <li>• Slot G</li> <li>• Slot H</li> <li>• Slot I</li> <li>• Slot J</li> <li>• Slot K</li> <li>• Slot L</li> <li>• Slot M</li> <li>• Slot N</li> <li>• Too many cards installed</li> </ul>	Indicates the option card slot where the mA output card is located.
Hardware in mA output channels 5...8		

Table. 4.5.9 - 149. Measurement values reported by mA output cards.

Name	Range	Step	Description
mA in Channel 1	0.0000...24.0000mA	0.0001mA	Displays the measured mA value of the selected input channel.
mA in Channel 2			
mA Out Channel Input Magnitude now	$-10^7 \dots 10^7$	0.001	Displays the input value of the selected mA output channel at that moment.
mA Out Channel Outputs now	0.0000...24.0000mA	0.0001mA	Displays the output value of the selected mA output channel at that moment.

### 4.5.10 Programmable control switch

The programmable control switch is a control function that controls its binary output signal. This output signal can be controlled locally from the device's mimic or remotely from the RTU. The main purpose of programmable control switches is to block or enable function and to change function properties by changing the setting group. However, this binary signal can also be used for any number of other purposes, just like all other binary signals. Once a programmable control switch has been activated or disabled, it remains in that state until given a new command to switch to the opposite state (see the image below). The switch cannot be controlled by an auxiliary input, such as digital inputs or logic signals; it can only be controlled locally (mimic) or remotely (RTU).

Figure. 4.5.10 - 79. When a PCS has been controlled "ON" or "OFF", the PCS will keep its state.

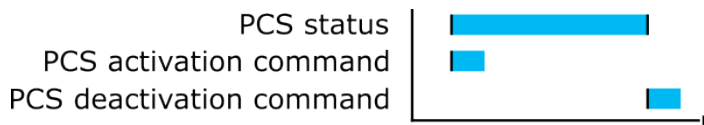

### Setting up a switch in the mimic editor

Figure. 4.5.10 - 80. Programmable control switch setup in the mimic editor.

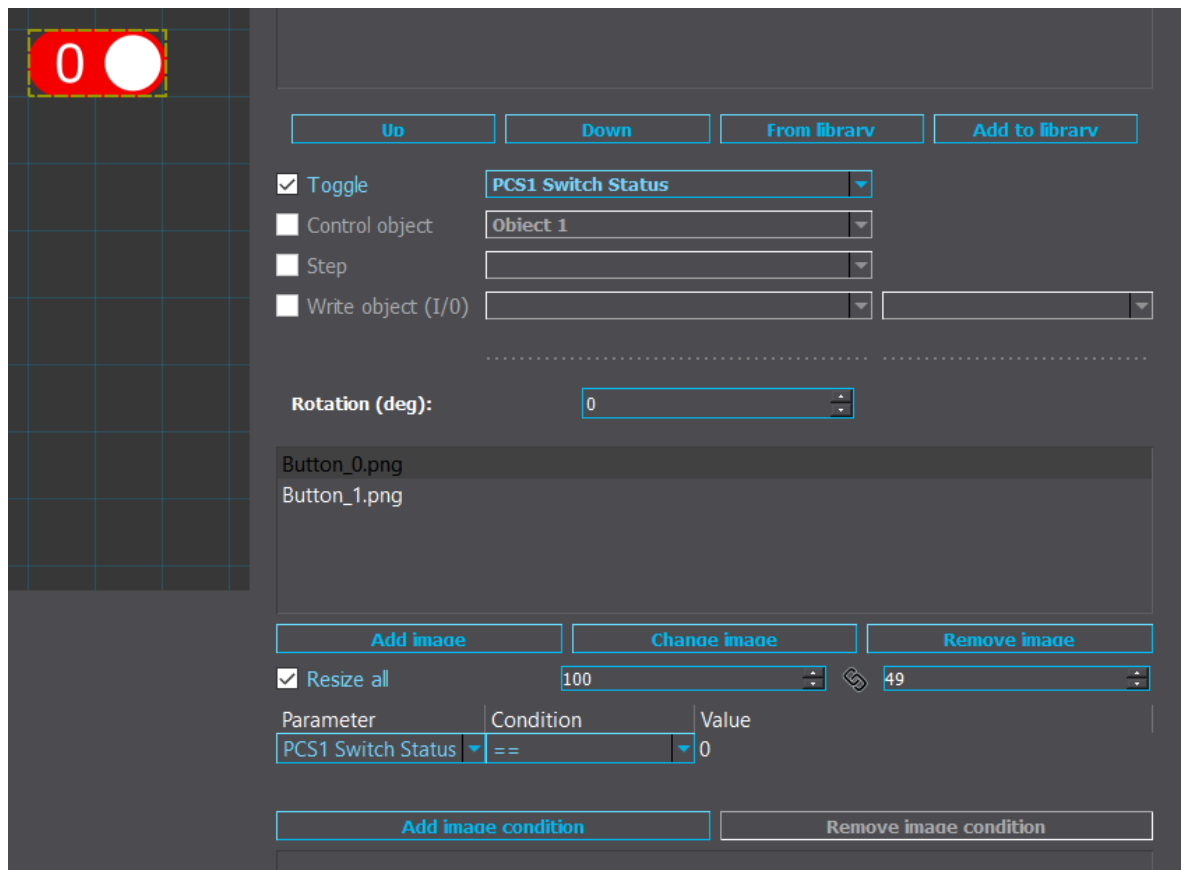

When an item has been added to the mimic, a collection of toggleable buttons can be found from the library with the "From library" button. To make an item a "programmable control switch", select one of the programmable switches (PCS1...5 Switch status) from the "Toggle" dropdown menu. After this select one of the images in the item ("Button\_0.png" and "Button\_1.png" in the example image above) and then choose the corresponding programmable control switch as the image condition. In the example image "Button\_0.png" is displayed when "PCS1 Switch Status == 0". Set the other image (in this case "Button\_1.png") to "PCS1 Switch Status == 1". When this is done, the image displayed by the item will follow the status of the programmable control switch.

If more than five toggleable switches are needed, logical inputs can also be set for the same purpose. The only difference is that the status of logical inputs are set to zero when the processor is rebooted, whereas programmable control switches keep the status.

## Settings.

These settings can be accessed at *Control* → *Device I/O* → *Programmable control switch*.

Table. 4.5.10 - 150. Settings.

Name	Range	Default	Description
Switch name	-	Switchx	The user-settable name of the selected switch. The name can be up to 32 characters long.
Access level for Mimic control	<ul style="list-style-type: none"> <li>• User</li> <li>• Operator</li> <li>• Configurator</li> <li>• Super user</li> </ul>	Configurator	Determines which access level is required to be able to control the programmable control switch via the Mimic.

## Events

The programmable control switch function (abbreviated "PCS" in event block names) generates events from the status changes in the events listed below. The user can select which event messages are stored in the main event buffer: ON, OFF, or both. The events triggered by the function are recorded with a time stamp. The function offers five (5) independent switches. The function's output signals can be used for direct I/O controlling and user logic programming.

Table. 4.5.10 - 151. Event messages.

Event block name	Event names
PCS	Switch 1 ON/OFF
PCS	Switch 2 ON/OFF
PCS	Switch 3 ON/OFF
PCS	Switch 4 ON/OFF
PCS	Switch 5 ON/OFF

## 4.5.11 Function buttons

AQ 250 devices have twelve (12) physical function buttons in the front panel of the device. The main purpose of function buttons is to block or enable functions and to change function properties by changing the setting group. However, this binary signal can also be used for any number of other purposes, just like all other binary signals.

Function buttons have two operation modes: "Press release" and "Toggle On/Off". In "Press release" mode the button status is active while the button is pressed down. In "Toggle On/Off" mode the button status toggles between "On" and "Off". Each button has a user configurable LED at the top left corner of the button. The LED can be configured to activate red, orange or green color from button status or any other logical binary signal.

General button settings and LED activation settings can be set at *Control* → *Device IO* → *Function Button Settings*.

### NOTICE!



The status of the function button outputs can only be controlled from the front panel i.e. can't be controlled remotely. Therefore it is recommended to use "a virtual button" (programmable control switches or logical inputs) if a toggleable signal must be controlled both locally and remotely.

Table. 4.5.11 - 152. User button settings

Name	Range	Step	Default	Description
Access level for function buttons	<ul style="list-style-type: none"> <li>User</li> <li>Operator</li> <li>Configurator</li> <li>Super user</li> </ul>	-	Operator	Determines which access level is required to be able to control the buttons.
Consider Local/ Remote switch for push-buttons	<ul style="list-style-type: none"> <li>No</li> <li>Yes</li> </ul>	-	No	When set to "Yes", the buttons can be operated only when the "L/R" button has been set to "Local" mode .
User editable description button 1...12	-	-	BTN1...12	Description of the button. If "Function button" view has been added to the "Carousel design", these descriptions are used for the buttons.
Function button 1...12 mode	Press release Toggle On/Off	-	Press release	Defines the operation mode of the button. In "Press release" mode the button signal is active while the button is pressed down. In "Toggle On/Off" mode the button signal changes status between "On" and "Off" each time the button is pressed.

Table. 4.5.11 - 153. Function button output signals

Signal name	Description
Status Function Button 1...12 ON/OFF	"On" and "Off" status of each button

## 4.5.12 Analog input scaling curves

Sometimes when measuring with RTD inputs, milliampere inputs and digital inputs the measurement might be inaccurate because the signal coming from the source is inaccurate. One common example of this is tap changer location indication signal not changing linearly from step to step. If the output difference between the steps are not equal to each other, measuring the incoming signal accurately is not enough. "Analog input scaling curves" menu can be used to take these inaccuracies into account.

Analog input scaling curve settings can be found at *Measurement* → *AI(mA, DI volt) scaling* menu.

Currently following measurements can be scaled with analog input scaling curves:

- RTD inputs and mA inputs in "RTD & mA input" option cards
- mA inputs in "4x mA output & 1x mA input" option cards
- mA input in "4x mA input & 1x mA output" option cards
- Digital input voltages

Table. 4.5.12 - 154. Main settings (input channel).

Name	Range	Step	Default	Description
Analog input scaling	<ul style="list-style-type: none"> <li>• Disabled</li> <li>• Activated</li> </ul>	-	Disabled	Enables and disables the input.
Scaling curve 1...10	<ul style="list-style-type: none"> <li>• Disabled</li> <li>• Activated</li> </ul>	-	Disabled	Enables and disables the scaling curve and the input measurement.
Curve 1...10 input signal select	<ul style="list-style-type: none"> <li>• S7 mA Input</li> <li>• S8 mA Input</li> <li>• S15 mA Input</li> <li>• S16 mA Input</li> <li>• DI1...DI20 Voltage</li> <li>• RTD S1...S16 Resistance</li> <li>• mA In 1 (I card 1)</li> <li>• mA In 2 (I card 2)</li> <li>• mA In 1 (T card 1)</li> <li>• mA In 2 (T card 1)</li> <li>• mA In 3 (T card 1)</li> <li>• mA In 4 (T card 1)</li> <li>• mA In 1 (T card 2)</li> <li>• mA In 2 (T card 2)</li> <li>• mA In 3 (T card 2)</li> <li>• mA In 4 (T card 2)</li> </ul>	-	S7 mA Input	Defines the measurement used by scaling curve.

Name	Range	Step	Default	Description
Curve 1...10 input signal filtering	<ul style="list-style-type: none"> <li>No</li> <li>Yes</li> </ul>	-	No	Enables calculation of the average of received signal.
Curve 1...10 input signal filter time constant	0.005...3800.000 s	0.005 s	1 s	Time constant for input signal filtering. This parameter is visible when "Curve 1...4 input signal filtering" has been set to "Yes".
Curve 1...10 input signal out of range set	<ul style="list-style-type: none"> <li>No</li> <li>Yes</li> </ul>	-	No	Enables out of range signals. If input signal is out of minimum and maximum limits, "ASC1...4 input out of range" signal is activated.
Curve1...10 input minimum	-1 000 000.00...1 000 000.00	0.00001	0	Defines the minimum input of the curve. If input is below the set limit, "ASC1...4 input out of range" is activated.
Curve 1...10 input	-1 000 000.00...1 000 000.00	0.00001	-	Displays the input measurement received by the curve.
Curve1...10 input maximum	-1 000 000.00...1 000 000.00	0.00001	0	Defines the maximum input of the curve. If input is above the set limit, "ASC1...4 input out of range" is activated.
Curve1...10 output	-1 000 000.00...1 000 000.00	0.00001	-	Displays the output of the curve.

The input signal filtering parameter calculates the average of received signals according to the set time constant. This is why rapid changes and disturbances (such as fast spikes) are smothered. The Nyquist rate states that the filter time constant must be at least double the period time of the disturbance process signal. For example, the value for the filter time constant is 2 seconds for a 1 second period time of a disturbance oscillation.

$$H(s) = \frac{Wc}{s+Wc} = \frac{1}{1+s/Wc}$$

When the curve signal is out of range, it activates the "ASC1...10 input out of range" signal, which can be used inside logic or with other functions of the device. The signal can be assigned directly to an output relay or to an LED in the I/O matrix. The "Out of range" signal is activated, when the measured signal falls below the set input minimum limit, or when it exceeds the input maximum limit.

If for some reason the input signal is lost, the value is fixed to the last actual measured cycle value. The value does not go down to the minimum if it has been something else at the time of the signal breaking.

Table. 4.5.12 - 155. Output settings and indications.

Name	Range	Step	Default	Description
Curve 1...10 update cycle	5...10 000ms	5ms	150ms	Defines the length of the input measurement update cycle. If the user wants a fast operation, this setting should be fairly low.

Name	Range	Step	Default	Description
Scaled value handling	<ul style="list-style-type: none"> <li>Floating point</li> <li>Integer out (Floor)</li> <li>Integer (Ceiling)</li> <li>Integer (Nearest)</li> </ul>	-	Floating point	Rounds the milliampere signal output as selected.
Input value 1	0...4000	0.000 01	0	The measured input value at Curve Point 1.
Scaled output value 1	$-10^7...10^7$	0.000 01	0	Scales the measured milliampere signal at Point 1.
Input value 2	0...4000	0.000 01	1	The measured input value at Curve Point 2.
Scaled output value 2	$-10^7...10^7$	0.000 01	0	Scales the measured milliampere signal at Point 2.
Add curvepoint 3...20	<ul style="list-style-type: none"> <li>Not used</li> <li>Used</li> </ul>	-	Not used	Allows the user to create their own curve with up to twenty (20) curve points, instead of using a linear curve between two points.

### 4.5.13 Logical outputs

Logical outputs are used for sending binary signals out from a logic that has been built in the logic editor. Logical signals can be used for blocking functions, changing setting groups, controlling digital outputs, activating LEDs, etc. The status of logical outputs can also be reported to a SCADA system. 64 logical outputs are available. The figure below presents a logic output example where a signal from the circuit breaker failure protection function controls the digital output relay number 3 ("OUT3") when the circuit breaker's cart status is "In".

Figure. 4.5.13 - 81. Logic output example. Logical output is connected to an output relay in matrix.

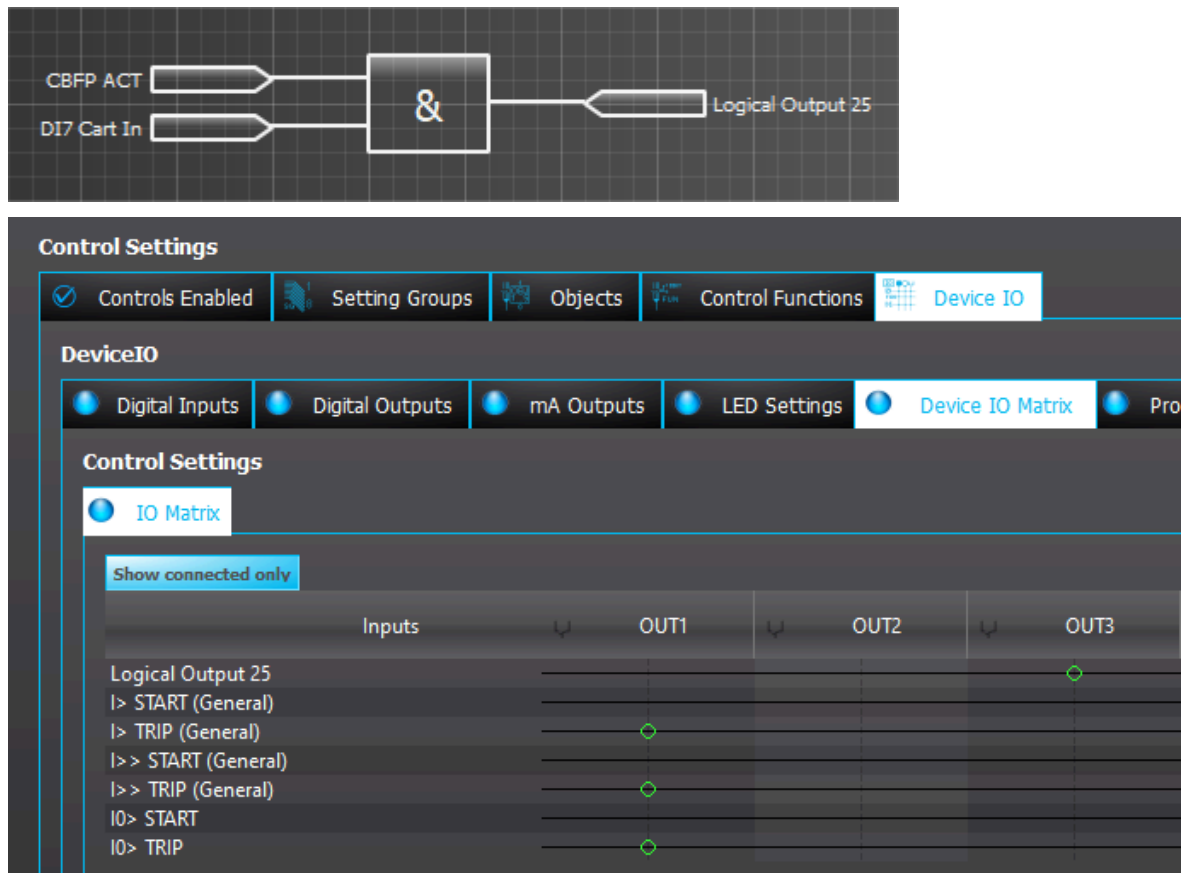

### Logical output descriptions

Logical outputs can be given a description. The user defined description are displayed in most of the menus:

- logic editor
- matrix
- block settings
- event history
- disturbance recordings
- etc.

Table. 4.5.13 - 156. Logical output user description.

Name	Range	Default	Description
User editable description LO1...64	1...31 characters	Logical output 1...64	Description of the logical output. This description is used in several menu types for easier identification.



**NOTICE!**

After editing user descriptions the event history will start to use the new description only after resetting the HMI. HMI can be reset from *General* → *Device info* → *HMI restart*.

## Events

The logical outputs (abbreviated "LOGIC" in event block names) generates events from the status changes in the events listed below. The user can select which event messages are stored in the main event buffer: ON, OFF, or both. The events triggered by the function are recorded with a time stamp. The function's output signals can be used for direct I/O controlling and user logic programming.

Table. 4.5.13 - 157. Event messages.

Event block name	Event names
LOGIC1	Logical out 1...32 ON/OFF
LOGIC3	Logical out 33...64 ON/OFF

### 4.5.14 Logical inputs

Logical inputs are binary signals that a user can control manually to change the behavior of the device or to give direct control commands. Logical inputs can be controlled with a virtual switch built in the mimic and from a SCADA system. Logical inputs are volatile signals: their status will always return to "0" when the device is rebooted. 32 logical inputs are available.

Logical inputs have two modes available: Hold and Pulse. When a logical input which has been set to "Hold" mode is controlled to "1", the input will switch to status "1" and it stays in that status until it is given a control command to go to status "0" or until the device is rebooted. When a logical input which has been set to "Pulse" mode is controlled to "1", the input will switch to status "1" and return back to "0" after 5 ms.

The figure below presents the operation of a logical input in Hold mode and in Pulse mode.

Figure. 4.5.14 - 82. Operation of logical input in "Hold" and "Pulse" modes.

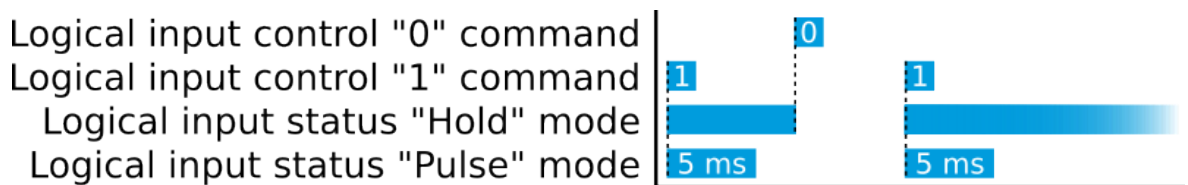

A logical input pulse can also be extended by connecting a DELAY-low gate to a logical output, as has been done in the example figure below.

Figure. 4.5.14 - 83. Extending a logical input pulse.

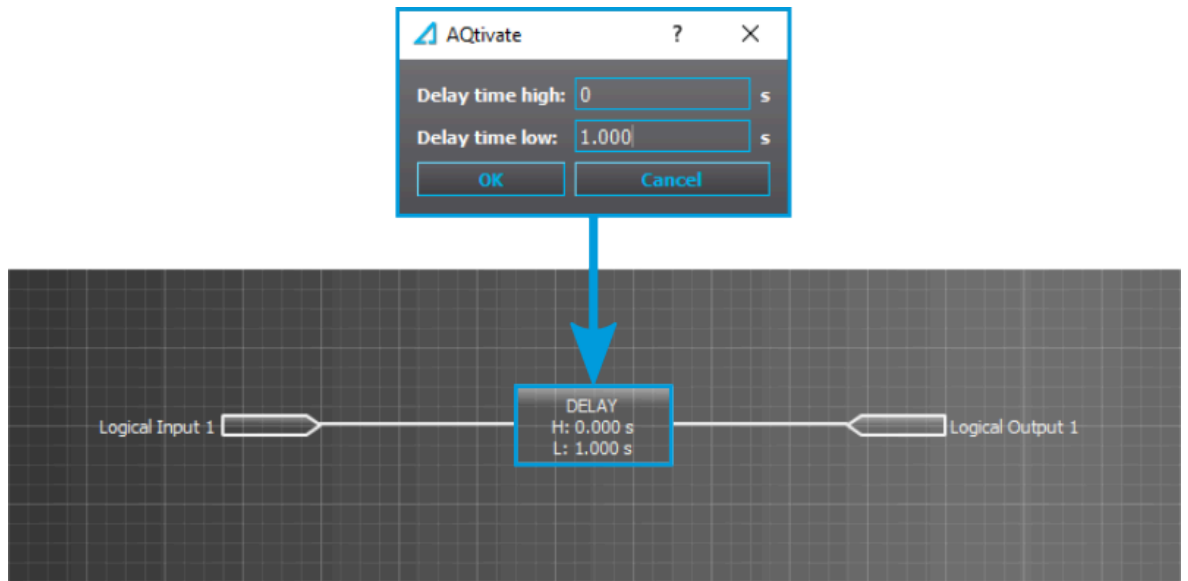

Logical input control "1" command  
 Logical input status "Pulse" mode  
 Logical output status

1  
 5 ms  
 Delay low setting

### Logical input descriptions

Logical inputs can be given a description. The user defined description are displayed in most of the menus:

- logic editor
- matrix
- block settings
- event history
- disturbance recordings
- etc.

Table. 4.5.14 - 158. Logical input user description.

Name	Range	Default	Description
User editable description LI1...32	1...31 characters	Logical input 1...32	Description of the logical input. This description is used in several menu types for easier identification.



**NOTICE!**

After editing user descriptions the event history will start to use the new description only after resetting the HMI. HMI can be reset from *General* → *Device info* → *HMI restart*.

## Events

The logical outputs (abbreviated "LOGIC" in event block names) generates events from the status changes in the events listed below. The user can select which event messages are stored in the main event buffer: ON, OFF, or both. The events triggered by the function are recorded with a time stamp. The function's output signals can be used for direct I/O controlling and user logic programming.

Table. 4.5.14 - 159. Event messages.

Event block name	Event names
LOGIC2	Logical in 1...32 ON/OFF

## 4.6 Monitoring functions

### 4.6.1 Voltage transformer supervision (60)

Voltage transformer supervision is used to detect errors in the secondary circuit of the voltage transformer wiring and during fuse failure. This signal is mostly used as an alarming function or to disable functions that require adequate voltage measurement.

Figure. 4.6.1 - 84. Secondary circuit fault in phase L1 wiring.

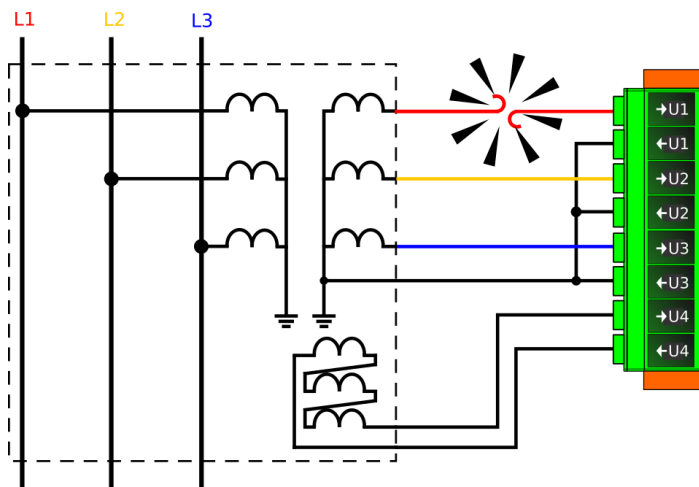
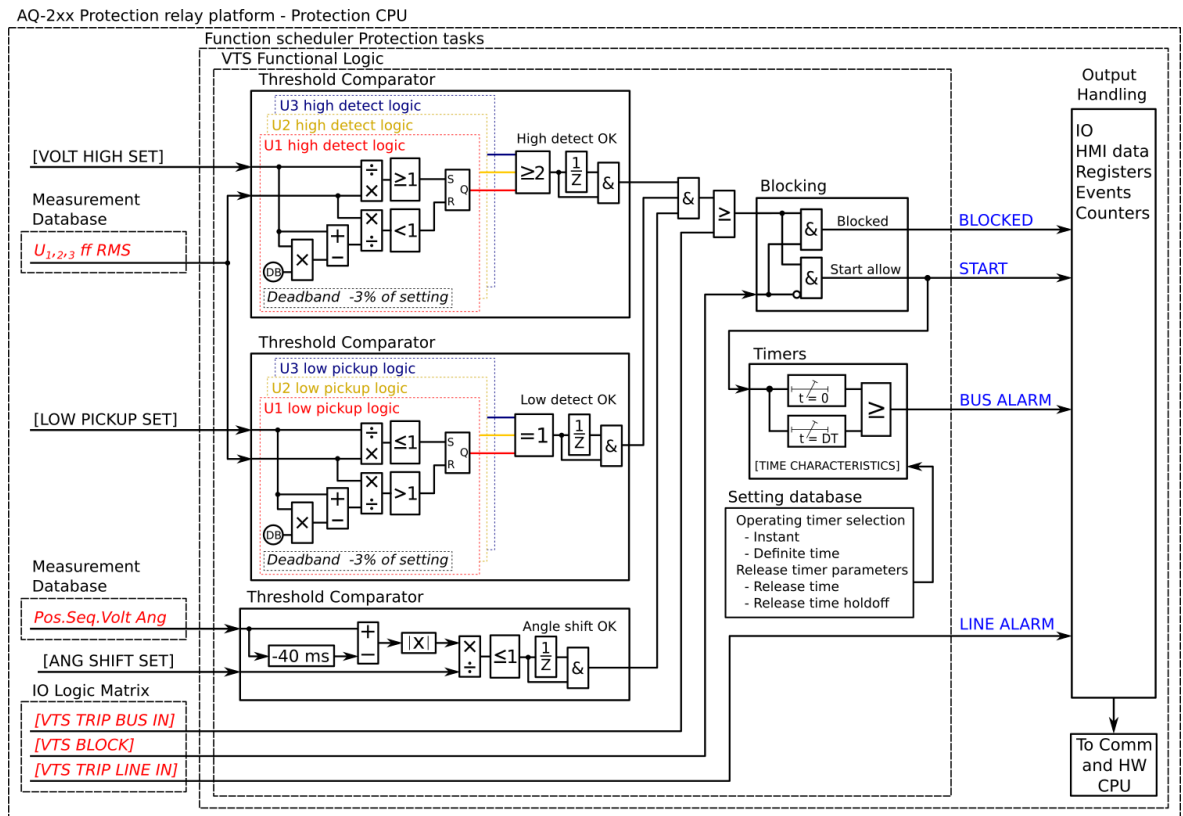

Figure. 4.6.1 - 85. Simplified function block diagram of the VTS function.



### Measured input

The function block uses fundamental frequency component of voltage measurement channels. The function uses calculated positive, negative and zero sequence voltages. The function also monitors the angle of each voltage channel.

Table. 4.6.1 - 160. Measurement inputs of the voltage transformer supervision function.

Signal	Description
U <sub>1</sub> RMS	Fundamental frequency component of U <sub>1</sub> /V voltage measurement
U <sub>2</sub> RMS	Fundamental frequency component of U <sub>2</sub> /V voltage measurement
U <sub>3</sub> RMS	Fundamental frequency component of U <sub>3</sub> /V voltage measurement
U <sub>4</sub> RMS	Fundamental frequency component of U <sub>4</sub> /V voltage measurement

### General settings

The following general settings define the general behavior of the function. These settings are static i.e. it is not possible to change them by editing the setting group.

Table. 4.6.1 - 161. General settings of the function.

Name	Range	Default	Description
VTS LN mode	<ul style="list-style-type: none"> <li>• On</li> <li>• Blocked</li> <li>• Test</li> <li>• Test/Blocked</li> <li>• Off</li> </ul>	On	Set mode of VTS block. This parameter is visible only when <i>Allow setting of individual LN mode</i> is enabled in <i>General</i> menu.
VTS force status to	<ul style="list-style-type: none"> <li>• Normal</li> <li>• Start</li> <li>• VTLinefail</li> <li>• VTBusfail</li> <li>• Blocked</li> </ul>	Normal	Force the status of the function. Visible only when <i>Enable stage forcing</i> parameter is enabled in <i>General</i> menu.

### Pick-up settings

The *Voltage low pick-up* and *Voltage high detect* setting parameters control the voltage-dependent pick-up and activation of the voltage transformer supervision function. The function's pick-up activates, if at least one of the three voltages is under the set *Voltage low pick-up* value, or if at least two of the three voltages exceed the set *Voltage high detect* value. The function constantly calculates the ratio between the setting values and the measured magnitude for each of the three phases.

Setting group selection controls the operating characteristics of the function, i.e. the user or user-defined logic can change function parameters while the function is running.

Table. 4.6.1 - 162. Pick-up settings.

Name	Range	Step	Default	Description
Voltage low pickup	$0.05 \dots 0.50 \times U_n$	$0.01 \times U_n$	$0.05 \times U_n$	If one the measured voltages is below low pickup value and two of the measured voltages exceed high detect value the function's pick-up activates.
Voltage high detect	$0.01 \dots 1.10 \times U_n$	$0.01 \times U_n$	$0.80 \times U_n$	
Angle shift limit	$2.00 \dots 90.00 \text{deg}$	$0.10 \text{deg}$	$5.00 \text{deg}$	If the difference between the present angle and the angle 40 ms before is above the set value, the function's pick-up is blocked.
Bus fuse fail check	<ul style="list-style-type: none"> <li>• No</li> <li>• Yes</li> </ul>	-	Yes	Selects whether or not the state of the bus fuse is supervised. The supervised signal is determined the "VTS MCB Trip bus" setting ( <i>I/O</i> → <i>Fuse failure inputs</i> ).
Line fuse fail check	<ul style="list-style-type: none"> <li>• No</li> <li>• Yes</li> </ul>	-	Yes	Selects whether or not the state of the line fuse is supervised. The supervised signal is determined by the "VTS MCB Trip line" setting ( <i>I/O</i> → <i>Fuse failure inputs</i> ).

The voltage transformer supervision can also report several different states of the measured voltage. These can be seen in the function's *INFO* menu.

Name	Description
Bus dead	No voltages.
Bus Live VTS Ok	All of the voltages are within the set limits.
Bus Live VTS Ok SEQ Rev	All of the voltages are within the set limits <b>BUT</b> the voltages are in a reversed sequence.
Bus Live VTS Ok SEQ Undef	Voltages are within the set limits <b>BUT</b> the sequence cannot be defined.
Bus Live VTS problem	Any of the VTS pick-up conditions are met.

### Read-only parameters

The function's *Info* page displays useful, real-time information on the state of the protection function. It is accessed either through the device's HMI display, or through the setting tool software when it is connected to the device and its Live Edit mode is active.

Table. 4.6.1 - 163. Information displayed by the function.

Name	Range	Step	Description
VTS LN behaviour	<ul style="list-style-type: none"> <li>On</li> <li>Blocked</li> <li>Test</li> <li>Test/Blocked</li> <li>Off</li> </ul>	-	Displays the mode of VTS block. This parameter is visible only when <i>Allow setting of individual LN mode</i> is enabled in <i>General</i> menu.
VTS condition	<ul style="list-style-type: none"> <li>Normal</li> <li>Start</li> <li>VTLinfail</li> <li>VTBusfail</li> <li>Blocked</li> </ul>	-	Displays status of the monitoring function.
Bus voltages	<ul style="list-style-type: none"> <li>Bus dead</li> <li>Bus Live VTS Ok SEQ Ok</li> <li>Bus Live VTS Ok SEQ Rev</li> <li>Bus Live VTS Ok SEQ Undef</li> <li>Bus Live VTS problem</li> </ul>	-	Displays the status of bus voltages.
Expected operating time	0.000...1800.000s	0.005s	Displays the expected operating time when a fault occurs.
Time remaining to trip	-1800.000...1800.000s	0.005s	When the function has detected a fault and counts down time towards a operation, this displays how much time is left before operation occurs.

## Function blocking

The block signal is checked in the beginning of each program cycle. The blocking signal is received from the blocking matrix in the function's dedicated input. If the blocking signal is not activated when the pick-up element activates, a START signal is generated and the function proceeds to the time characteristics calculation.

If the blocking signal is active when the pick-up element activates, a BLOCKED signal is generated and the function does not process the situation further. If the START function has been activated before the blocking signal, it resets and the release time characteristics are processed similarly to when the pick-up signal is reset.

The variables the user can set are binary signals from the system. The blocking signal needs to reach the device minimum of 5 ms before the set operating delay has passed in order for the blocking to activate in time.

## Operating time characteristics for activation

This function supports definite time delay (DT). For detailed information on these delay types please refer to the chapter "[General properties of a protection function](#)" and its section "[Operating time characteristics](#)".

## Events and registers

The voltage transformer supervision function (abbreviated "VTS" in event block names) generates events and registers from the status changes in the events listed below. The user can select which event messages are stored in the main event buffer: ON, OFF, or both. The events triggered by the function are recorded with a time stamp.

The function's outputs can be used for direct I/O controlling and user logic programming. The function also provides a resettable cumulative counter for the START, ALARM BUS, ALARM LINE and BLOCKED events.

Table. 4.6.1 - 164. Event messages.

Event block name	Event names
VTS1	Bus VT fail Start ON/OFF
VTS1	Bus VT fail Trip ON/OFF
VTS1	Bus VT fail Block ON/OFF
VTS1	Line VT fail ON/OFF
VTS1	Bus Fuse fail ON/OFF
VTS1	Line Fuse fail ON/OFF

The function registers its operation into the last twelve (12) time-stamped registers. The register of the function records the ON event process data for ACTIVATED, BLOCKED, etc. The table below presents the structure of the function's register content.

Table. 4.6.1 - 165. Register content.

Register	Description
Date and time	dd.mm.yyyy hh:mm:ss.mss
Event	Event name
Volt 1, 2, 3, 4 status	<ul style="list-style-type: none"> <li>No voltage</li> <li>Voltage OK</li> <li>Low voltage</li> </ul>
System status	<ul style="list-style-type: none"> <li>Bus dead</li> <li>Bus live, VTS OK, Seq. OK</li> <li>Bus live, VTS OK, Seq. reversed</li> <li>Bus live, VTS OK, Seq. undefined</li> <li>Bus live, VTS fault</li> </ul>
Input A, B, C, D angle diff	0.00...360.00deg
Trip time remaining	Time remaining to alarm 0...1800s
Setting group in use	Setting group 1...8 active

## 4.6.2 Voltage total harmonic distortion (THD)

The voltage total harmonic distortion (THD) function is used for monitoring the content of the voltage harmonic. The THD is a measurement of the harmonic distortion present, and it is defined as the ratio between the sum of all harmonic components' powers and the power of the fundamental frequency (RMS).

Harmonics can be caused by different sources in electric networks such as electric machine drives, thyristor controls, etc. The function's monitoring of the voltage can be used to alarm of the harmonic content rising too high; this can occur when there is an electric quality requirement in the protected unit, or when the harmonics generated by the process need to be monitored.

The function constantly measures the phase voltage magnitudes as well as the harmonic content of the monitored signals up to the 31<sup>st</sup> harmonic component. The user can set the alarming limits if the application so requires.

The monitoring of the measured signals can be selected to be based either on an amplitude ratio or on the above-mentioned power ratio. The difference is in the calculation formula (as shown below):

Figure. 4.6.2 - 86. THD calculation formulas.

$$THD_P = \frac{U_{x2}^2 + U_{x3}^2 + U_{x4}^2 \dots U_{x31}^2}{U_{x1}^2}$$

, where  
U = measured voltage,  
x= measurement input,  
n = harmonic number

$$THD_A = \sqrt{\frac{U_{x2}^2 + U_{x3}^2 + U_{x4}^2 \dots U_{x31}^2}{U_{x1}^2}}$$

, where  
U = measured voltage,  
x= measurement input,  
n = harmonic number

While both of these formulas exist, the power ratio ( $THD_P$ ) is recognized by the IEEE, and the amplitude ratio ( $THD_A$ ) is recognized by the IEC.

Figure. 4.6.2 - 87. Simplified function block diagram of the total harmonic distortion monitor function.

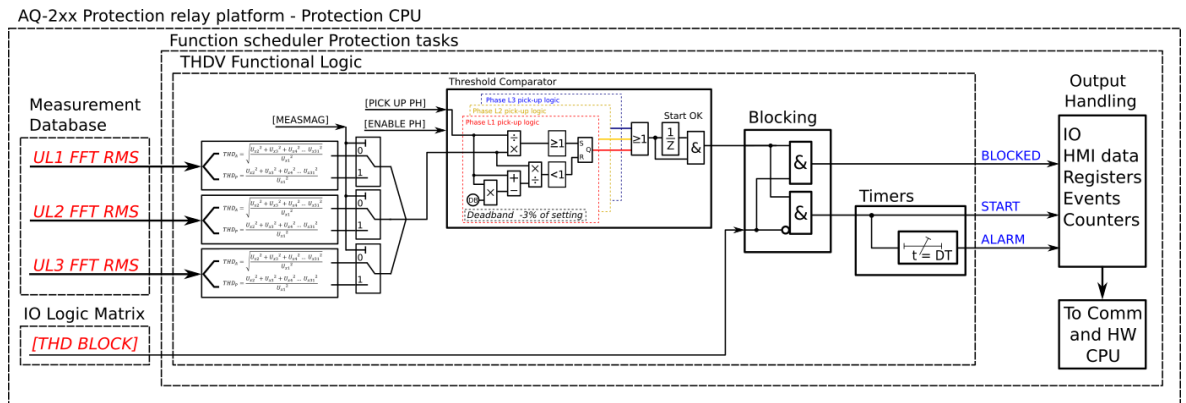

### Measured input

The function block uses analog voltage measurement values. The function always uses FFT measurement of the whole harmonic specter of 32 components from each measured voltage channel. From these measurements the function calculates either the amplitude ratio or the power ratio.

Table. 4.6.2 - 166. Measurement inputs of the total harmonic distortion monitor function.

Signal	Description
U <sub>1</sub> FFT	FFT measurement of U <sub>1</sub> /V voltage channel
U <sub>2</sub> FFT	FFT measurement of U <sub>2</sub> /V voltage channel
U <sub>3</sub> FFT	FFT measurement of U <sub>3</sub> /V voltage channel

The selection of the calculation method is made with a setting parameter (common for all measurement channels).

### General settings

The following general settings define the general behavior of the function. These settings are static i.e. it is not possible to change them by editing the setting group.

Table. 4.6.2 - 167. General settings.

Name	Range	Default	Description
THDV > LN mode	<ul style="list-style-type: none"> <li>On</li> <li>Blocked</li> <li>Test</li> <li>Test/Blocked</li> <li>Off</li> </ul>	On	Set mode of THDV block. This parameter is visible only when <i>Allow setting of individual LN mode</i> is enabled in <i>General</i> menu.
Measurement magnitude	<ul style="list-style-type: none"> <li>Amplitude</li> <li>Power</li> </ul>	Amplitude	Defines which available measured magnitude the function uses.

## Pick-up settings

The THDV pick-up setting parameter controls the the pick-up and activation of the function. They define the maximum allowed measured voltage THD before action from the function. Before the function activates alarm signals, their corresponding pick-up elements need to be activated with the setting parameter *Enable THD alarm*. The function constantly calculates the ratio between the setting values and the calculated voltage THD. The reset ratio of 97 % is built into the function and is always relative to the setting value. The setting value is common for all measured phases. When the calculated THD exceeds the pick-up value (in single, dual or all phases), it triggers the pick-up operation of the function.

Setting group selection controls the operating characteristics of the function, i.e. the user or user-defined logic can change function parameters while the function is running.

Table. 4.6.2 - 168. Pick-up settings.

Name	Range	Step	Default	Description
Enable THDV alarm	<ul style="list-style-type: none"> <li>Enabled</li> <li>Disabled</li> </ul>	-	Enabled	Enables and disables the THD alarm function.
THDV pick-up	0.10...100.00%	0.01%	10.00%	The pick-up setting for the THD alarm element from the phase voltages. At least one of the phases' measured THD value has to exceed this setting in order for the alarm signal to activate.

## Read-only parameters

The function's *Info* page displays useful, real-time information on the state of the protection function. It is accessed either through the device's HMI display, or through the setting tool software when it is connected to the device and its Live Edit mode is active.

Table. 4.6.2 - 169. Information displayed by the function.

Name	Range	Description
THDV> LN behaviour	<ul style="list-style-type: none"> <li>On</li> <li>Blocked</li> <li>Test</li> <li>Test/Blocked</li> <li>Off</li> </ul>	Displays the mode of THDV block. This parameter is visible only when <i>Allow setting of individual LN mode</i> is enabled in <i>General</i> menu.
THDV condition	<ul style="list-style-type: none"> <li>Normal</li> <li>Start</li> <li>Alarm</li> <li>Blocked</li> </ul>	Displays status of the monitoring function.

## Function blocking

The block signal is checked in the beginning of each program cycle. The blocking signal is received from the blocking matrix in the function's dedicated input. If the blocking signal is not activated when the pick-up element activates, a START signal is generated and the function proceeds to the time characteristics calculation.

If the blocking signal is active when the pick-up element activates, a BLOCKED signal is generated and the function does not process the situation further. If the START function has been activated before the blocking signal, it resets and the release time characteristics are processed similarly to when the pick-up signal is reset.

The variables the user can set are binary signals from the system. The blocking signal needs to reach the device minimum of 5 ms before the set operating delay has passed in order for the blocking to activate in time.

### Operating time characteristics for activation and reset

This function supports definite time delay (DT). The following table presents the setting parameters for the function's time characteristics.

Table. 4.6.2 - 170. Settings for operating time characteristics.

Name	Range	Step	Default	Description
THDV alarm delay	0.000...1800.000s	0.005s	10.000s	Defines the delay for the alarm timer from the phase voltages' measured THD.

### Events and registers

The voltage total harmonic distortion monitor function (abbreviated "THDV" in event block names) generates events and registers from the status changes in the events listed below. The user can select which event messages are stored in the main event buffer: ON, OFF, or both. The events triggered by the function are recorded with a time stamp.

The function's outputs can be used for direct I/O controlling and user logic programming. The function also provides a resettable cumulative counter for the START, ALARM and BLOCKED events.

Table. 4.6.2 - 171. Event messages.

Event block name	Event names
THDV1	Voltage THD Start ON/OFF
THDV1	Voltage THD Alarm ON/OFF
THDV1	Voltage Blocked ON/OFF

The function registers its operation into the last twelve (12) time-stamped registers. The register of the function records the ON event process data for START, ALARM and BLOCKED. The table below presents the structure of the function's register content.

Table. 4.6.2 - 172. Register content.

Register	Description
Date and time	dd.mm.yyyy hh:mm:ss.mss
Event	Event name
UL1, UL2, UL3 THDV	Start/Alarm Voltage THD of each phase.
Setting group in use	Setting group 1...8 active.

### 4.6.3 Measurement recorder

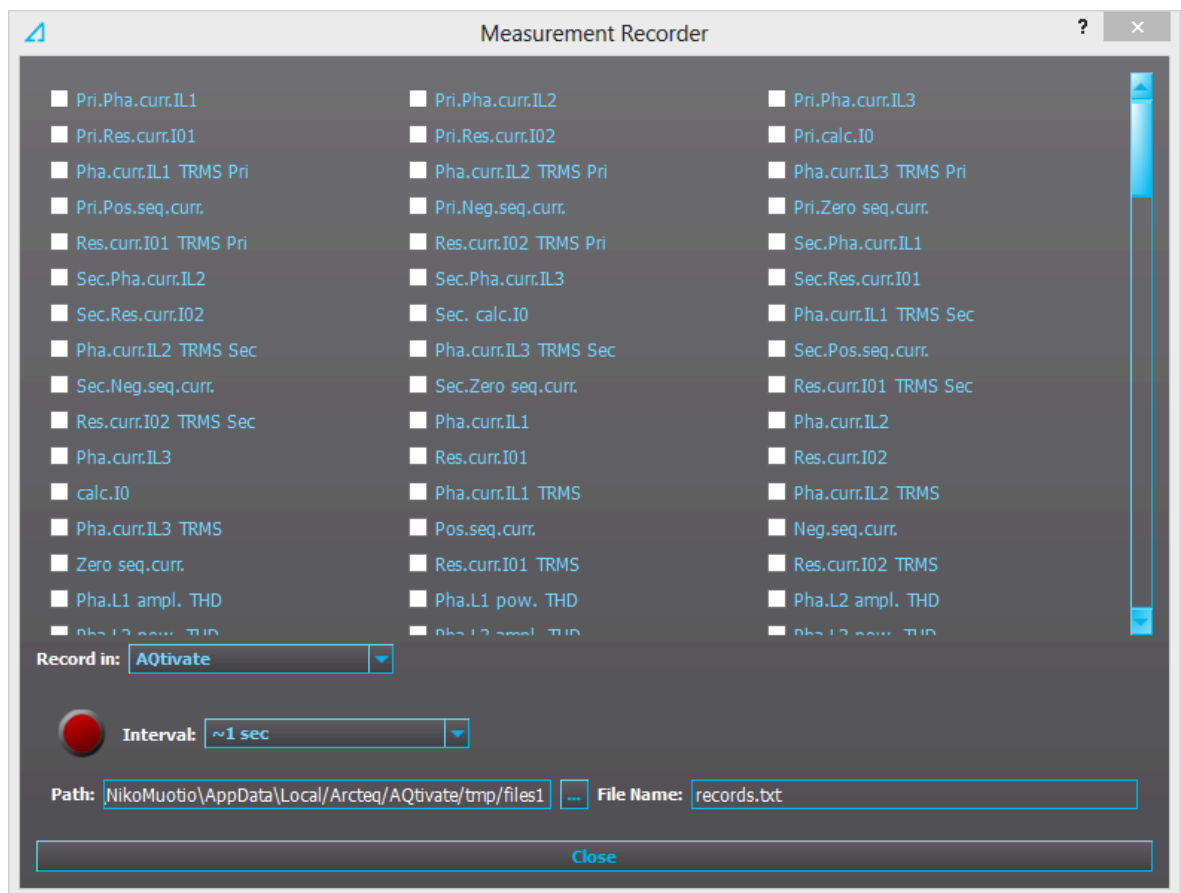

Measurements can be recorded to a file with the measurement recorder. The chosen measurements are recorded at selected intervals. In the "Measurement recorder" window, the measurements the user wants to be recorded can be selected by checking their respective check boxes. In order for the measurement recorder to activate, a connection to a device must be established via the setting tool software and its Live Edit mode must be enabled (see the setting tool manual for more information). Navigate to the measurement recorder through *Tools* → *Miscellaneous tools* → *Measurement recorder*. The recording interval can be changed from the "Interval" drop-down menu. From the "Record in" drop-down menu the user can also choose whether the measurements are recorded in the setting tool or in the device.

If the recording is done in the setting tool, both the setting tool software and its Live Edit mode have to be activated. The user can change the recording file location by editing the "Path" field. File names can also be changed with the "File name" field. Hitting the "Record" button (the big red circle) starts the recorder. Please note that closing the "Measurement recorder" window does not stop the recording; that can only be done by hitting the "Stop" button (the big blue circle).

If the recording is done in the device, only the recording interval needs to be set before recording can be started. The setting tool estimates the maximum recording time, which depends on the recording interval. When the measurement recorder is running, the measurements can be viewed in graph form with the AQtivate PRO software (see the image below).

Figure. 4.6.3 - 88. Measurement recorder values viewed with AQtivate PRO.



Table. 4.6.3 - 173. Available analog signals.

Current measurements	P-P Curr.I" L3	L1 Imp.React.Ind.E.Mvarh
Pri.Pha.Curr.IL1	P-P Curr.I"01	L1 Imp.React.Ind.E.kvarh
Pri.Pha.Curr.IL2	P-P Curr.I"02	L1 Exp/Imp React.Ind.E.bal.Mvarh
Pri.Pha.Curr.IL3	Pha.angle I" L1	L1 Exp/Imp React.Ind.E.bal.kvarh
Pri.Res.Curr.I01	Pha.angle I" L2	L2 Exp.Active Energy MWh
Pri.Res.Curr.I02	Pha.angle I" L3	L2 Exp.Active Energy kWh
Pri.Calc.I0	Res.Curr.angle I"01	L2 Imp.Active Energy MWh
Pha.Curr.IL1 TRMS Pri	Res.Curr.angle I"02	L2 Imp.Active Energy kWh
Pha.Curr.IL2 TRMS Pri	Calc.I"0.angle	L2 Exp/Imp Act. E balance MWh
Pha.Curr.IL3 TRMS Pri	I" Pos.Seq.Curr.angle	L2 Exp/Imp Act. E balance kWh
Pri.Pos.Seq.Curr.	I" Neg.Seq.Curr.angle	L2 Exp.React.Cap.E.Mvarh
Pri.Neg.Seq.Curr.	I" Zero.Seq.Curr.angle	L2 Exp.React.Cap.E.kvarh
Pri.Zero.Seq.Curr.	<b>Voltage measurements</b>	L2 Imp.React.Cap.E.Mvarh
Res.Curr.I01 TRMS Pri	U1Volt Pri	L2 Imp.React.Cap.E.kvarh
Res.Curr.I02 TRMS Pri	U2Volt Pri	L2 Exp/Imp React.Cap.E.bal.Mvarh
Sec.Pha.Curr.IL1	U3Volt Pri	L2 Exp/Imp React.Cap.E.bal.kvarh
Sec.Pha.Curr.IL2	U4Volt Pri	L2 Exp.React.Ind.E.Mvarh

Sec.Pha.Curr.IL3	U1Volt Pri TRMS	L2 Exp.React.Ind.E.kvarh
Sec.Res.Curr.I01	U2Volt Pri TRMS	L2 Imp.React.Ind.E.Mvarh
Sec.Res.Curr.I02	U3Volt Pri TRMS	L2 Imp.React.Ind.E.kvarh
Sec.Calc.I0	U4Volt Pri TRMS	L2 Exp/Imp React.Ind.E.bal.Mvarh
Pha.Curr.IL1 TRMS Sec	Pos.Seq.Volt.Pri	L2 Exp/Imp React.Ind.E.bal.kvarh
Pha.Curr.IL2 TRMS Sec	Neg.Seq.Volt.Pri	L3 Exp.Active Energy MWh
Pha.Curr.IL3 TRMS Sec	Zero.Seq.Volt.Pri	L3 Exp.Active Energy kWh
Sec.Pos.Seq.Curr.	U1Volt Sec	L3 Imp.Active Energy MWh
Sec.Neg.Seq.Curr.	U2Volt Sec	L3 Imp.Active Energy kWh
Sec.Zero.Seq.Curr.	U3Volt Sec	L3 Exp/Imp Act. E balance MWh
Res.Curr.I01 TRMS Sec	U4Volt Sec	L3 Exp/Imp Act. E balance kWh
Res.Curr.I02 TRMS Sec	U1Volt Sec TRMS	L3 Exp.React.Cap.E.Mvarh
Pha.Curr.IL1	U2Volt Sec TRMS	L3 Exp.React.Cap.E.kvarh
Pha.Curr.IL2	U3Volt Sec TRMS	L3 Imp.React.Cap.E.Mvarh
Pha.Curr.IL3	U4Volt Sec TRMS	L3 Imp.React.Cap.E.kvarh
Res.Curr.I01	Pos.Seq.Volt.Sec	L3 Exp/Imp React.Cap.E.bal.Mvarh
Res.Curr.I02	Neg.Seq.Volt.Sec	L3 Exp/Imp React.Cap.E.bal.kvarh
Calc.I0	Zero.Seq.Volt.Sec	L3 Exp.React.Ind.E.Mvarh
Pha.Curr.IL1 TRMS	U1Volt p.u.	L3 Exp.React.Ind.E.kvarh
Pha.Curr.IL2 TRMS	U2Volt p.u.	L3 Imp.React.Ind.E.Mvarh
Pha.Curr.IL3 TRMS	U3Volt p.u.	L3 Imp.React.Ind.E.kvarh
Pos.Seq.Curr.	U4Volt p.u.	L3 Exp/Imp React.Ind.E.bal.Mvarh
Neg.Seq.Curr.	U1Volt TRMS p.u.	L3 Exp/Imp React.Ind.E.bal.kvarh
Zero.Seq.Curr.	U2Volt TRMS p.u.	Exp.Active Energy MWh
Res.Curr.I01 TRMS	U3Volt p.u.	Exp.Active Energy kWh
Res.Curr.I02 TRMS	U4Volt p.u.	Imp.Active Energy MWh
Pha.L1 ampl. THD	Pos.Seq.Volt. p.u.	Imp.Active Energy kWh
Pha.L2 ampl. THD	Neg.Seq.Volt. p.u.	Exp/Imp Act. E balance MWh
Pha.L3 ampl. THD	Zero.Seq.Volt. p.u.	Exp/Imp Act. E balance kWh
Pha.L1 pow. THD	U1Volt Angle	Exp.React.Cap.E.Mvarh
Pha.L2 pow. THD	U2Volt Angle	Exp.React.Cap.E.kvarh
Pha.L3 pow. THD	U3Volt Angle	Imp.React.Cap.E.Mvarh

Res.I01 ampl. THD	U4Volt Angle	Imp.React.Cap.E.kvarh
Res.I01 pow. THD	Pos.Seq.Volt. Angle	Exp/Imp React.Cap.E.bal.Mvarh
Res.I02 ampl. THD	Neg.Seq.Volt. Angle	Exp/Imp React.Cap.E.bal.kvarh
Res.I02 pow. THD	Zero.Seq.Volt. Angle	Exp.React.Ind.E.Mvarh
P-P Curr.IL1	System Volt UL12 mag	Exp.React.Ind.E.kvarh
P-P Curr.IL2	System Volt UL12 mag (kV)	Imp.React.Ind.E.Mvarh
P-P Curr.IL3	System Volt UL23 mag	Imp.React.Ind.E.kvarh
P-P Curr.I01	System Volt UL23 mag (kV)	Exp/Imp React.Ind.E.bal.Mvarh
P-P Curr.I02	System Volt UL31 mag	Exp/Imp React.Ind.E.bal.kvarh
Pha.angle IL1	System Volt UL31 mag (kV)	<b>Other measurements</b>
Pha.angle IL2	System Volt UL1 mag	TM> Trip expect mode
Pha.angle IL3	System Volt UL1 mag (kV)	TM> Time to 100% T
Res.Curr.angle I01	System Volt UL2 mag	TM> Reference T curr.
Res.Curr.angle I02	System Volt UL2 mag (kV)	TM> Active meas curr.
Calc.I0.angle	System Volt UL3 mag	TM> T est.with act. curr.
Pos.Seq.Curr.angle	System Volt UL3 mag (kV)	TM> T at the moment
Neg.Seq.Curr.angle	System Volt U0 mag	TM> Max.Temp.Rise All.
Zero.Seq.Curr.angle	System Volt U0 mag (kV)	TM> Temp.Rise atm.
Pri.Pha.Curr.I"L1	System Volt U1 mag	TM> Hot Spot estimate
Pri.Pha.Curr.I"L2	System Volt U1 mag (kV)	TM> Hot Spot Max. All
Pri.Pha.Curr.I"L3	System Volt U2 mag	TM> Used k for amb.temp
Pri.Res.Curr.I"01	System Volt U2 mag (kV)	TM> Trip delay remaining
Pri.Res.Curr.I"02	System Volt U3 mag	TM> Alarm 1 time to rel.
Pri.Calc.I"0	System Volt U3 mag (kV)	TM> Alarm 2 time to rel.
Pha.Curr.I"L1 TRMS Pri	System Volt U4 mag	TM> Inhibit time to rel.
Pha.Curr.I"L2 TRMS Pri	System Volt U4 mag (kV)	TM> Trip time to rel.
Pha.Curr.I"L3 TRMS Pri	System Volt UL12 ang	S1 Measurement
I" Pri.Pos.Seq.Curr.	System Volt UL23 ang	S2 Measurement
I" Pri.Neg.Seq.Curr.	System Volt UL31 ang	S3 Measurement
I" Pri.Zero.Seq.Curr.	System Volt UL1 ang	S4 Measurement
Res.Curr.I"01 TRMS Pri	System Volt UL2 ang	S5 Measurement
Res.Curr.I"02 TRMS Pri	System Volt UL3 ang	S6 Measurement

Sec.Pha.Curr.I"L1	System Volt U0 ang	S7 Measurement
Sec.Pha.Curr.I"L2	System Volt U1 ang	S8 Measurement
Sec.Pha.Curr.I"L3	System Volt U2 ang	S9 Measurement
Sec.Res.Curr.I"01	System Volt U3 ang	S10 Measurement
Sec.Res.Curr.I"02	System Volt U4 ang	S11 Measurement
Sec.Calc.I"0	<b>Power measurements</b>	S12 Measurement
Pha.Curr.I"L1 TRMS Sec	L1 Apparent Power (S)	Sys.meas.frqs
Pha.Curr.I"L2 TRMS Sec	L1 Active Power (P)	f atm.
Pha.Curr.I"L3 TRMS Sec	L1 Reactive Power (Q)	f meas from
I" Sec.Pos.Seq.Curr.	L1 Tan(phi)	SS1.meas.frqs
I" Sec.Neg.Seq.Curr.	L1 Cos(phi)	SS1f meas from
I" Sec.Zero.Seq.Curr.	L2 Apparent Power (S)	SS2 meas.frqs
Res.Curr.I"01 TRMS Sec	L2 Active Power (P)	SS2f meas from
Res.Curr.I"02 TRMS Sec	L2 Reactive Power (Q)	L1 Bias current
Pha.Curr.I"L1	L2 Tan(phi)	L1 Diff current
Pha.Curr.I"L2	L2 Cos(phi)	L1 Char current
Pha.Curr.I"L3	L3 Apparent Power (S)	L2 Bias current
Res.Curr.I"01	L3 Active Power (P)	L2 Diff current
Res.Curr.I"02	L3 Reactive Power (Q)	L2 Char current
Calc.I"0	L3 Tan(phi)	L3 Bias current
Pha.Curr.I"L1 TRMS	L3 Cos(phi)	L3 Diff current
Pha.Curr.I"L2 TRMS	3PH Apparent Power (S)	L3 Char current
Pha.Curr.I"L3 TRMS	3PH Active Power (P)	HV I0d> Bias current
I" Pos.Seq.Curr.	3PH Reactive Power (Q)	HV I0d> Diff current
I" Neg.Seq.Curr.	3PH Tan(phi)	HV I0d> Char current
I" Zero.Seq.Curr.	3PH Cos(phi)	LV I0d> Bias current
Res.Curr.I"01 TRMS	<b>Energy measurements</b>	LV I0d> Diff current
Res.Curr.I"02 TRMS	L1 Exp.Active Energy MWh	LV I0d> Char current
Pha.IL"1 ampl. THD	L1 Exp.Active Energy kWh	Curve1 Input
Pha.IL"2 ampl. THD	L1 Imp.Active Energy MWh	Curve1 Output
Pha.IL"3 ampl. THD	L1 Imp.Active Energy kWh	Curve2 Input
Pha.IL"1 pow. THD	L1 Exp/Imp Act. E balance MWh	Curve2 Output

Pha.IL"2 pow. THD	L1 Exp/Imp Act. E balance kWh	Curve3 Input
Pha.IL"3 pow. THD	L1 Exp.React.Cap.E.Mvarh	Curve3 Output
Res.I"01 ampl. THD	L1 Exp.React.Cap.E.kvarh	Curve4 Input
Res.I"01 pow. THD	L1 Imp.React.Cap.E.Mvarh	Curve4 Output
Res.I"02 ampl. THD	L1 Imp.React.Cap.E.kvarh	Control mode
Res.I"02 pow. THD	L1 Exp/Imp React.Cap.E.bal.Mvarh	Motor status
P-P Curr.I"L1	L1 Exp/Imp React.Cap.E.bal.kvarh	Active setting group
P-P Curr.I"L2	L1 Exp.React.Ind.E.Mvarh	
	L1 Exp.React.Ind.E.kvarh	

#### 4.6.4 Fault register

The fault register function records the value of the selected magnitudes at the time of a pre-defined trigger signal. A typical application is the recording of fault currents or voltages at the time of the breaker trips; it can also be used to record the values from any trigger signal set by the user. The user can select whether the function records per-unit values or primary values. Additionally, the user can set the function to record overcurrent fault types or voltage fault types. The function operates instantly from the trigger signal.

The fault register function has an integrated fault display which shows the current fault values when the tripped by one of the following functions:

- 
- 
- 
- 
- 
- f<(underfrequency)
- f> (overfrequency)
- U< (undervoltage)
- U> (overvoltage)
- U1/U2 >/< (sequence voltage)
- U0> (residual voltage)
- 
- 
- 
- 
-

Figure. 4.6.4 - 89. 12 latest recordings can be accessed from HMI if "VrecRegisters" view has been enabled in "Carousel designer" tool.

I>Trip	10/02/2025 08:12:09.580	A-B-C	
I>Trip	10/02/2025 08:11:18.084	B-C	
I>Trip	10/02/2025 08:11:04.012	B-C	
I>Trip	10/02/2025 08:10:44.619	B-C	I>Trip 10/02/2025 08:12:09.580 A-B-C
I>>>Trip	10/02/2025 08:03:38.431	-	SG1
I>>>Trip	10/02/2025 08:02:50.259	-	Mag 1 :0.00
I>>Trip	10/02/2025 08:02:39.069	-	Mag 2 :0.00
I>>>>Trip	10/02/2025 08:02:28.479	-	Mag 3 :0.00
I>Trip	10/02/2025 08:02:20.968	-	Mag 4 :0.00
-	-	-	Mag 5 :0.00
-	-	-	Mag 6 :0.00
-	-	-	Mag 7 :0.00
			Mag 8 :0.00

### Measured input

The function block uses analog current and voltage measurement values. Based on these values, the device calculates the primary and secondary values of currents, voltages, powers, and impedances as well as other values.

The user can set up to eight (8) magnitudes to be recorded when the function is triggered. An overcurrent fault type, a voltage fault type, and a tripped stage can be recorded and reported straight to SCADA.

**NOTICE!**

 The available measurement values depend on the device type. If only current analog measurements are available, the recorder can solely use signals which only use current. The same applies, if only voltage analog measurements are available.

Table. 4.6.4 - 174. Voltage based measurements available.

Voltages	Description
UL1Mag, UL2Mag, UL3Mag, UL12Mag, UL23Mag, UL31Mag, U0Mag, U0CalcMag	The magnitudes of phase voltages, of phase-to-phase voltages, and of residual voltages.
U1 Pos.seq V mag, U2 Neg.seq V mag	The positive sequence voltage and the negative sequence voltage.
UL1Ang, UL2Ang, UL3Ang, UL12Ang, UL23Ang, UL31Ang, U0Ang, U0CalcAng	The angles of phase voltages, of phase-to-phase voltages, and of residual voltages.
U1 Pos.seq V Ang, U2 Neg.seq V Ang	The positive sequence angle and the negative sequence angle.

Table. 4.6.4 - 175. Other measurements available.

Others	Description
System f.	The tracking frequency in use at that moment.
Ref f1	The reference frequency 1.
Ref f2	The reference frequency 2.
M thermal T	The motor thermal temperature.
F thermal T	The feeder thermal temperature.
T thermal T	The transformer thermal temperature.
RTD meas 1...16	The RTD measurement channels 1...16.
Ext RTD meas 1...8	The external RTD measurement channels 1...8 (ADAM module).

### Reported values

When triggered, the function holds the recorded values of up to eight channels, as set. In addition to this tripped stage, the overcurrent fault type and the voltage fault types are reported to SCADA.

Table. 4.6.4 - 176. Reported values.

Name	Range	Description
Tripped stage	<ul style="list-style-type: none"> <li>• -</li> <li>• I&gt; Trip</li> <li>• I&gt;&gt; Trip</li> <li>• I&gt;&gt;&gt; Trip</li> <li>• I&gt;&gt;&gt;&gt; Trip</li> <li>• IDir&gt; Trip</li> <li>• IDir&gt;&gt; Trip</li> <li>• IDir&gt;&gt;&gt; Trip</li> <li>• IDir&gt;&gt;&gt;&gt; Trip</li> <li>• U&gt; Trip</li> <li>• U&gt;&gt; Trip</li> <li>• U&gt;&gt;&gt; Trip</li> <li>• U&gt;&gt;&gt;&gt; Trip</li> <li>• U&lt; Trip</li> <li>• U&lt;&lt; Trip</li> <li>• U&lt;&lt;&lt; Trip</li> <li>• U&lt;&lt;&lt;&lt; Trip</li> <li>• IO&gt; TRIP</li> <li>• IO&gt;&gt; Trip</li> <li>• IO&gt;&gt;&gt; Trip</li> <li>• IO&gt;&gt;&gt;&gt; Trip</li> <li>• IODir&gt; Trip</li> <li>• IODir&gt;&gt; Trip</li> <li>• IODir&gt;&gt;&gt; Trip</li> <li>• IODir&gt;&gt;&gt;&gt; Trip</li> <li>• f&gt; Trip</li> <li>• f&gt;&gt; Trip</li> <li>• f&gt;&gt;&gt; Trip</li> <li>• f&gt;&gt;&gt;&gt; Trip</li> <li>• f&lt; Trip</li> <li>• f&lt;&lt; Trip</li> <li>• f&lt;&lt;&lt; Trip</li> <li>• f&lt;&lt;&lt;&lt; Trip</li> <li>• P&gt; Trip</li> <li>• P&lt; Trip</li> <li>• Prev&gt; Trip</li> <li>• T&gt; Trip</li> <li>• I2&gt; Trip</li> <li>• I2&gt;&gt; Trip</li> <li>• I2&gt;&gt;&gt; Trip</li> <li>• I2&gt;&gt;&gt;&gt; Trip</li> <li>• U1/2 &gt; Trip</li> <li>• U1/2 &gt;&gt; Trip</li> <li>• U1/2 &gt;&gt;&gt; Trip</li> <li>• U1/2 &gt;&gt;&gt;&gt; Trip</li> <li>• U0&gt; Trip</li> <li>• U0&gt;&gt; Trip</li> <li>• U0&gt;&gt;&gt; Trip</li> <li>• U0&gt;&gt;&gt;&gt; Trip</li> </ul>	The tripped stage.
Overcurrent fault type	<ul style="list-style-type: none"> <li>• A-G</li> <li>• B-G</li> <li>• A-B</li> <li>• C-G</li> <li>• A-C</li> <li>• B-C</li> <li>• A-B-C</li> </ul>	The overcurrent fault type.

Name	Range	Description
Voltage fault type	<ul style="list-style-type: none"> <li>• A(AB)</li> <li>• B(BC)</li> <li>• A-B(AB-BC)</li> <li>• C(CA)</li> <li>• A-C(AB-CA)</li> <li>• B-C(BC-CA)</li> <li>• A-B-C</li> <li>• Overfrequency</li> <li>• Underfrequency</li> <li>• Overpower</li> <li>• Underpower</li> <li>• Reversepower</li> <li>• Thermal overload</li> <li>• Unbalance</li> <li>• Harmonic overcurrent</li> <li>• Residual overvoltage</li> </ul>	The voltage fault type.
Magnitude 1...8	0.000...1800.000 A/V/p.u.	The recorded value in one of the eight channels.

## Events

The fault register function (abbreviated "VREC" in event block names) generates events from the status changes in the events listed below. The user can select which event messages are stored in the main event buffer: ON, OFF, or both. The events triggered by the function are recorded with a time stamp.

Table. 4.6.4 - 177. Event messages.

Event block name	Event name
VREC1	Recorder triggered ON/OFF

## 4.6.5 Event logger

Event logger records status changes of protection functions, digital inputs, logical signals etc. Events are recorded with a timestamp. The time stamp resolution is 1 ms. Up to 15 000 events can be stored at once. When 15 000 events have been recorded, the event history will begin to remove the oldest events to make room for new events. You can find more information about event masks in the selected function's "Events" tab. Event masks determine what is recorded into the event history; they are configured in each function's individual settings in the *Protection*, *Control* and *Monitoring* menu. Event history is accessible with PC setting tool (*Tools* → *Events and Logs* → *Event history*) and from the device HMI if "Events" view has been configured with Carousel designer in PC setting tool.

### Event overload detection

Continuous generation of a high number of nuisance events may have adverse effects on the operation and communication capabilities of the device. A high number of nuisance events may end up being generated due to mistakes in configuration and/or installation. For example, mistakes in logic configuration or RTD sensor wiring, in conjunction with suitable event mask settings may generate an excessive number of unintended events. Event overload detector looks for a condition where over 200 events are being generated inside one (1) second window (more than 1 event every 5 milliseconds on average). If such a condition is detected, further events are blocked and an IRF (Internal Relay Fault-message) is issued. The event blocking is released and the IRF can be cleared after 5 seconds if the overload condition has been corrected. Other device operations, such as protection and communication, remain available even during the event overload condition.

## 4.6.6 Disturbance recorder (DR)

The disturbance recorder is a high-capacity (64 MB permanent flash memory) and fully digital recorder integrated to the protection relay. The maximum sample rate of the recorder's analog channels is 64 samples per cycle. Up to 20 analog recording channels and 96 digital channels are supported. Maximum capacity of recordings is 100.

The recorder provides an effective tool to analyze the performance of the power system during network disturbance situations. The recorder's output is in general COMTRADE format and it is compatible with most recording viewers and injection devices. The files are based on the IEEE standard C37.111-1999. Captured recordings can be injected as playback with secondary testing tools that support the COMTRADE file format. Playback of files might help to analyze the fault, or can be simply used for educational purposes.

### Analog and digital recording channels

Table. 4.6.6 - 178. Analog recording channels.

Signal	Description
IL1	Phase current $I_{L1}$
IL2	Phase current $I_{L2}$
IL3	Phase current $I_{L3}$
I01c	Residual current $I_{01}$ coarse*
I01f	Residual current $I_{01}$ fine*
I02c	Residual current $I_{02}$ coarse*
I02f	Residual current $I_{02}$ fine*
IL1"	Phase current $I_{L1}$ (CT card 2)
IL2"	Phase current $I_{L2}$ (CT card 2)
IL3"	Phase current $I_{L3}$ (CT card 2)
I01"c	Residual current $I_{01}$ coarse* (CT card 2)
I01"f	Residual current $I_{01}$ fine* (CT card 2)
I02"c	Residual current $I_{02}$ coarse* (CT card 2)
I02"f	Residual current $I_{02}$ fine* (CT card 2)
U1(2)VT1	Line-to-neutral $U_{L1}$ or line-to-line voltage $U_{L12}$ (VT card 1)
U2(3)VT1	Line-to-neutral $U_{L2}$ or line-to-line voltage $U_{L23}$ (VT card 1)
U3(1)VT1	Line-to-neutral $U_{L3}$ or line-to-line voltage $U_{L31}$ (VT card 1)
U0(ss)VT1	Zero sequence voltage $U_0$ or synchrocheck voltage $U_{SS}$ (VT card 1)
F tracked 1	Tracked frequency of reference 1
F tracked 2	Tracked frequency of reference 2

Signal	Description
F tracked 3	Tracked frequency of reference 3
ISup	Current measurement module voltage supply supervision (CT card 1)
ISup"	Current measurement module voltage supply supervision (CT card 2)
USup	Voltage measurement module voltage supply supervision (VT card 1)
IL1""	Phase current $I_{L1}$ (CT card 3)
IL2""	Phase current $I_{L2}$ (CT card 3)
IL3""	Phase current $I_{L3}$ (CT card 3)
I01""c	Residual current $I_{01}$ coarse* (CT card 3)
I01""f	Residual current $I_{01}$ fine* (CT card 3)
I02""c	Residual current $I_{02}$ coarse* (CT card 3)
I02""f	Residual current $I_{02}$ fine* (CT card 3)
ISup_3	Current measurement module voltage supply supervision (CT card 3)
UL1(2)VT2	Line-to-neutral $U_{L1}$ or line-to-line voltage $U_{L12}$ (VT card 2)
UL2(3)VT2	Line-to-neutral $U_{L2}$ or line-to-line voltage $U_{L23}$ (VT card 2)
UL3(1)VT2	Line-to-neutral $U_{L3}$ or line-to-line voltage $U_{L31}$ (VT card 2)
U0(SS)VT2	Zero sequence voltage $U_0$ or synchrocheck voltage $U_{ss}$ (VT card 2)
USup_2	Voltage measurement module voltage supply supervision (VT card 2)

**\*NOTE:** There are two signals for each residual current channel in the disturbance recorder: coarse and fine. A coarse signal is capable of sampling in the full range of the current channel but suffers a loss of accuracy at very low currents. A fine signal is capable of sampling at very low currents and with high accuracy but cuts off at higher currents. Table below lists performance of both channels with fine and coarse gain.

Table. 4.6.6 - 179. Residual current channel performance with coarse or residual gain.

Channel	Coarse gain range	Fine gain range	Fine gain peak
I01	0...150 A	0...10 A	15 A
I02	0...75 A	0...5 A	8 A

## Recording settings and triggering

Disturbance recorder can be triggered manually or automatically by using the dedicated triggers. Every signal listed in "Digital recording channels" can be selected to trigger the recorder.

The number of analog and digital channels together with the sample rate and the time setting affect the recording size. See calculation examples below in the section titled "Estimating the maximum length of total recording time". The recording size affects how many recordings can be stored at a time, but the number can't exceed 100 recordings.

Table. 4.6.6 - 180. Recorder control settings.

Name	Range	Description
Recorder enabled	<ul style="list-style-type: none"> <li>Enabled</li> <li>Disabled</li> </ul>	Enables and disables the disturbance recorder function.
Recorder status	<ul style="list-style-type: none"> <li>Recorder ready</li> <li>Recording triggered</li> <li>Recording and storing</li> <li>Storing recording</li> <li>Recorder full</li> <li>Wrong config</li> </ul>	<p>Indicates the status of recorder.</p> <p>"Wrong config" is activated if:</p> <ul style="list-style-type: none"> <li>"Pre-triggering time" is longer than "Max length of recording" setting</li> <li>"Max amount of recordings" is "1" and "Recording mode" is "FIFO".</li> <li>"1ms" digital channel sample rate is selected when analog channel sample rate is 8 or 16 s/c.</li> </ul>
Clear record	0...2 <sup>32</sup> -1	Clears selected recording. If "1" is inserted, first recording will be cleared from memory. If "10" is inserted, tenth (10th) recording will be cleared from memory.
Manual trigger	<ul style="list-style-type: none"> <li>-</li> <li>Trig</li> </ul>	Triggers disturbance recording manually. This parameter will return back to "-" automatically.
Clear all records	<ul style="list-style-type: none"> <li>-</li> <li>Clear</li> </ul>	Clears all disturbance recordings.
Clear newest record	<ul style="list-style-type: none"> <li>-</li> <li>Clear</li> </ul>	Clears the newest stored disturbance recording.
Clear oldest record	<ul style="list-style-type: none"> <li>-</li> <li>Clear</li> </ul>	Clears the oldest stored disturbance recording.
Max. number of recordings	0...100	Displays the maximum number of recordings that can be stored in the device's memory with settings currently in use. The maximum number of recordings can go up to 100.
Max. length of a recording	0.000...1800.000s	Displays the maximum length of a single recording.
Max. location of the pre-trigger	0.000...1800.000s	Displays the highest pre-triggering time that can be set with the settings currently in use.
Recordings in memory	0...100	Displays how many recordings are stored in the memory.

Table. 4.6.6 - 181. Recorder trigger setting.

Name	Description
Recorder trigger	Selects the trigger input(s). Clicking the "Edit" button brings up a pop-up window, and checking the boxes enable the selected triggers.

Table. 4.6.6 - 182. Recorder settings.

Name	Range	Default	Description
Recording length	0.100...1800.000s	1s	Sets the length of a recording.
Recording mode	<ul style="list-style-type: none"> <li>FIFO</li> <li>Keep olds</li> </ul>	FIFO	Selects what happens when the memory is full. "FIFO" (= first in, first out) replaces the oldest stored recording with the latest one. "Keep olds" does not accept new recordings.
Analog channel samples	<ul style="list-style-type: none"> <li>64s/c</li> <li>32s/c</li> <li>16s/c</li> <li>8s/c</li> </ul>	64s/c	Selects the sample rate of the disturbance recorder in samples per cycle. The samples are saved from the measured wave according to this setting.
Digital channel samples	<ul style="list-style-type: none"> <li>5 ms</li> <li>1 ms</li> </ul>	5 ms	The fixed sample rate of the recorded digital channels. Recorded digital channels can be chosen with "Recorder digital channels" below. NOTE: 1 ms sample rate can't be used when analog channel sample rate is 8 or 16 s/c.
Pretriggering time	0.2...30.0s	0.2s	Sets the recording length before the trigger.
Analog recording CH1...CH20	0...8 freely selectable channels	-	Selects the analog channel for recording. Please see the list of all available analog channels in the section titled "Analog and digital recording channels".
Automatically get recordings	<ul style="list-style-type: none"> <li>Disabled</li> <li>Enabled</li> </ul>	Disabled	Enables and disables the automatic transfer of recordings. The recordings are taken from the device's protection CPU and transferred to the device's FTP directory in the communication CPU; the FTP client then automatically loads the recordings from the device and transfers them further to the SCADA system. Please note that when this setting is enabled, all new disturbance recordings will be pushed to the FTP server of the device. Up to six (6) recordings can be stored in the FTP at once. Once those six recordings have been retrieved and removed, more recordings will then be pushed to the FTP. When a recording has been sent to the FTP server of the device, it is no longer accessible through setting tools <i>Disturbance recorder</i> → <i>Get DR files</i> command.
Recorder digital channels	0...96 freely selectable channels	-	Selects the digital channel for recording. Please see the list of all available digital channels in the section titled "Analog and digital recording channels".

**NOTICE!**

 The disturbance recorder is not ready unless the "Max. length of a recording" parameter is showing some value other than zero. At least one trigger input has to be selected in the "Recorder Trigger" setting to fulfill this term.

**NOTICE!**

 When writing new disturbance recorder settings to the device, any existing recordings in the device memory will be deleted.

## Estimating the maximum length of total recording time

Once the disturbance recorder's settings have been made and loaded to the device, the device automatically calculates and displays the total length of recordings. However, if the user wishes to confirm this calculation, they can do so with the following formula. Please note that the formula assumes there are no other files in the FTP that share the 64 MB space.

$$\frac{\text{Total sample reserve}}{(f_n * (Ch_{an} + 1) * SR) + (200 \text{ Hz} * Ch_{dig})}$$

Where:

- total sample reserve = the number of samples available in the FTP when no other files are saved; calculated by dividing the total number of available bytes by 4 bytes (=the size of one sample); e.g. 64 306 588 bytes/4 bytes = 16 076 647 samples.
- $f_n$  = the nominal frequency (Hz).
- $Ch_{an}$  = the number of analog channels recorded; "+ 1" stands for the time stamp for each recorded sample.
- $SR$  = the selected sample rate (s/c).
- 200 Hz = the rate at which digital channels are always recorded, i.e. 5 ms.
- $Ch_{dig}$  = the number of digital channels recorded.

For example, let us say the nominal frequency is 50 Hz, the selected sample rate is 64 s/c, nine (9) analog channels and two (2) digital channels record. The calculation is as follows:

$$\frac{16\,076\,647 \text{ samples}}{(50 \text{ Hz} * (9 + 1) * 64) + (200 \text{ Hz} * 2)} \approx 496 \text{ s}$$

Therefore, the maximum recording length in our example is approximately 496 seconds.

## Application example

This chapter presents an application example of how to set the disturbance recorder and analyze its output. The recorder is configured by using the setting tool software or device HMI, and the results are analyzed with the AQviewer software (is automatically downloaded and installed with AQtivate). Registered users can download the latest tools from the Arcteq website ([arcteq.fi/downloads/](http://arcteq.fi/downloads/)).

In this example, we want the recordings to be made according to the following specifications:

- the recording length is 6.0 s
- the sample rate is 64 s/c (therefore, with a 50 Hz system frequency a sample is taken every 312.5  $\mu$ s)
- the analog channels 1...8 are used
- digital channels are tracked every 5 ms
- the first activation of the overcurrent stage trip ( $I > TRIP$ ) triggers the recorder
- the pre-triggering time is 5 (ie. how long is recorded before the  $I > TRIP$  signal) and the post-triggering time is 1 s

The image below shows how these settings are placed in the setting tool.

Figure. 4.6.6 - 90. Disturbance recorder settings.

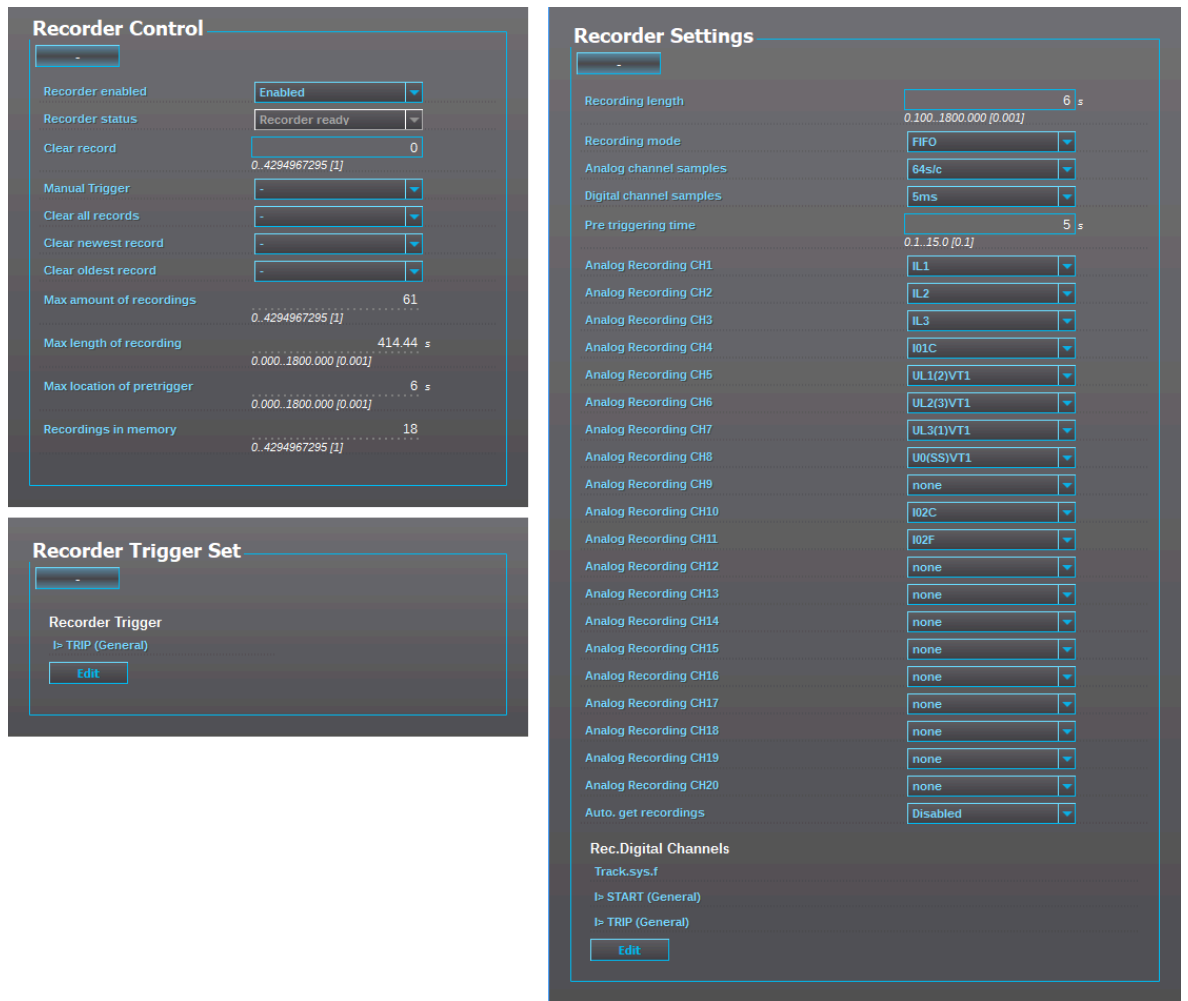
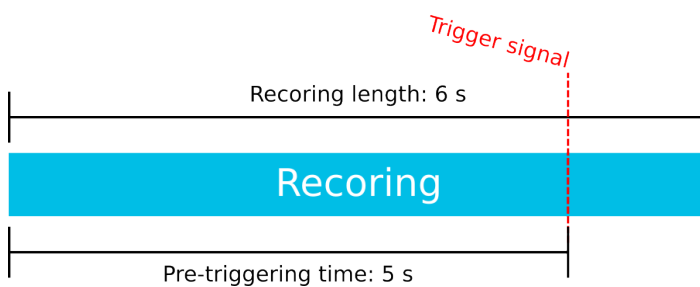
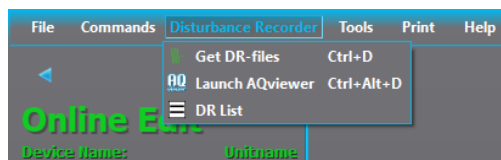

Figure. 4.6.6 - 91. Effects of recording length and pre-triggering time signals. This example is based on the settings shown above.



When there is at least one recording in the device's memory, that recording can be analyzed by using the AQviewer software (see the image below). However, the recording must first be made accessible to AQviewer. The user can read it from the device's memory (*Disturbance recorder* → *Get DR-files*). Alternatively, the user can load the recordings individually (*Disturbance recorder* → *DR List*) from a folder in the PC's hard disk drive; the exact location of the folder is described in *Tools* → *Settings* → *DR path*.



The user can also launch the AQviewer software from the *Disturbance recorder* menu. AQviewer software instructions can be found in AQtivate Instruction manual (<https://www.arcteq.com/documents-and-software/>).

## Events

The disturbance recorder function (abbreviated "DR" in event block names) generates events and registers from the status changes in the events listed below. Events cannot be masked off. The events triggered by the function are recorded with a time stamp.

Table. 4.6.6 - 183. Event messages.

Event block name	Event names
DR1	Recorder triggered ON/OFF
DR1	Recorder memory cleared
DR1	Oldest record cleared
DR1	Recorder memory full ON/OFF
DR1	Recording ON/OFF
DR1	Storing recording ON/OFF
DR1	Newest record cleared

### 4.6.7 User access control

As a factory default, no user level is locked with a password in a device. In order to activate the different user levels, push the **Lock** button on the device's front panel and set the desired passwords for the user levels.

Figure. 4.6.7 - 92. User access control view.

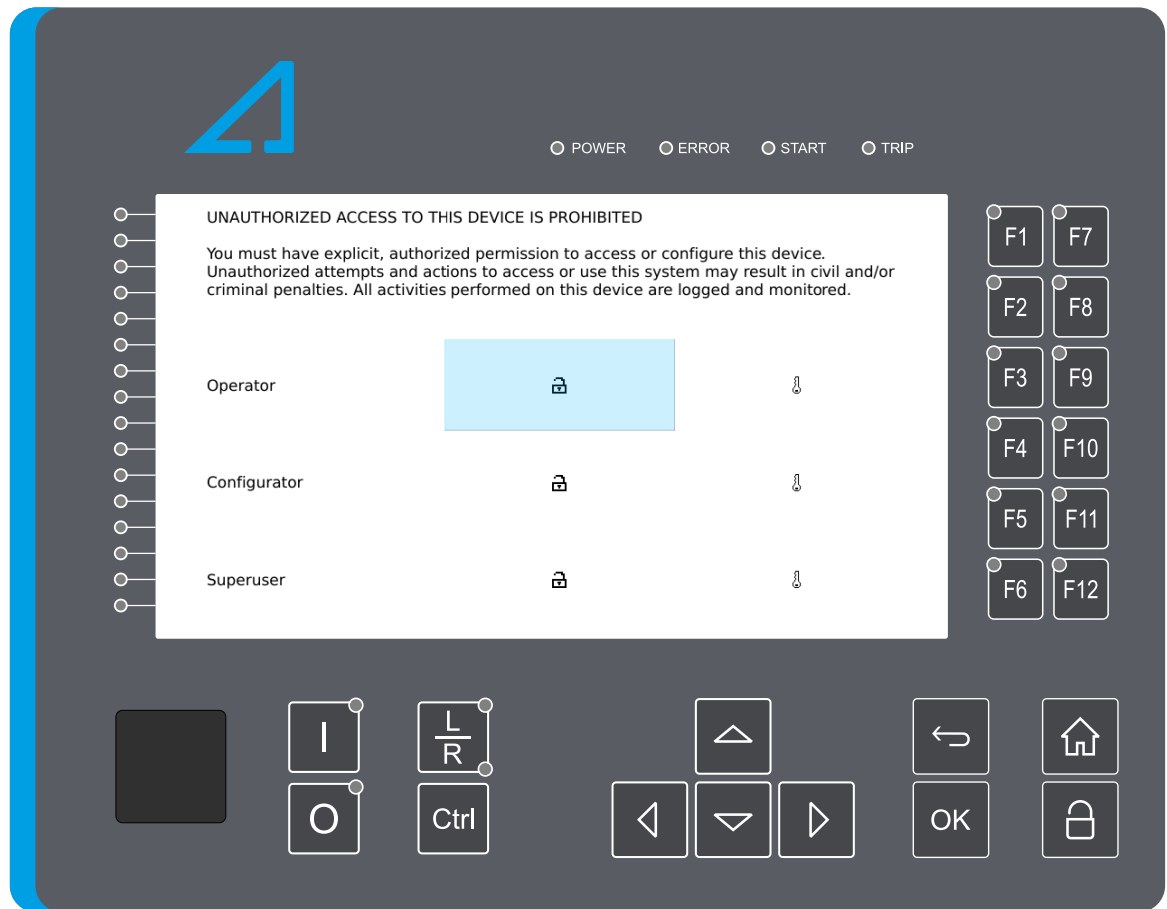

**NOTICE!**

Passwords can only be set locally in an HMI.

You can set a new password for a user level by selecting the key icon next to the user level's name. After this you can lock the user level by pressing the Return key while the lock is selected. If you need to change the password, you can select the key icon again and give a new password. To remove the password, set the password to "0" (zero). Please note that in order to do this the user level whose password is being changed must be unlocked.

As a general rule the access levels are divided as follows:

- User: Can view any menus and settings but cannot change any settings, nor operate breakers or other equipment.
- Operator: Can view any menus and settings but cannot change any settings BUT can operate breakers and other equipment.
- Configurator: Can change most settings such as basic protection pick-up levels or time delays, breaker control functions, signal descriptions etc. and can operate breakers and other equipment.
- Super user: Can change any setting and can operate breakers and other equipment.

**Advanced user access control settings**

More detailed settings for user access can be found from *Monitoring* → *User Access Control* menu.

Table. 4.6.7 - 184. UAC settings.

Name	Range	Default	Description
Enable user group - Operator	<ul style="list-style-type: none"> <li>Enabled</li> <li>Disabled</li> </ul>	Enabled	Enables or disables "Operator" user group.
Enable user group - Configurator	<ul style="list-style-type: none"> <li>Enabled</li> <li>Disabled</li> </ul>	Enabled	Enables or disables "Configurator" user group.
Minimum password length	0...128	1	Sets the minimum character length for passwords.
Number of fail attempts before lock	0...1000	3	Sets the number of failed attempts allowed before locking the user level.
Lock period after max fail attempts	0...86400000 s	0 s	Wait time after locking a user level.
HMI session period before logout	5...86400 s	900 s	Time delay for logging out in the HMI. Timer will start the countdown when there are no front panel button presses.
Setting tool session period before logout	5...86400 s	900 s	Time delay for logging out in the setting tool. Timer will start the countdown when there are no key presses or mouse movement.

Table. 4.6.7 - 185. UAC management.

Name	Range	Default	Description
Enable UAC management	<ul style="list-style-type: none"> <li>Enabled</li> <li>Disabled</li> </ul>	Disabled	If UAC has been enabled, the function will set default passwords for the user levels, if no passwords have been set. The function will also monitor if the passwords have been expired.
Enable default passwords	<ul style="list-style-type: none"> <li>Enabled</li> <li>Disabled</li> </ul>	Disabled	If enabled, user levels will use the default passwords, if no passwords have been set. The default passwords are: <ul style="list-style-type: none"> <li>Operator: Oper17</li> <li>Configurator: Conf12</li> <li>Super user: Supr98</li> </ul>
Password change interval - Operator	0...1000 day(s)	0 day(s)	Required interval for changing passwords. If the password hasn't been changed on time, "Password expired" parameter will change to "True", diagnostic alarm will be activated and an entry to the audit log will be added.
Password change interval - Configurator	0...1000 day(s)	0 day(s)	
Password change interval - Superuser	0...1000 day(s)	0 day(s)	
Password expired - Operator	<ul style="list-style-type: none"> <li>False</li> <li>True</li> </ul>	-	If the password hasn't been changed before the "password change interval" has expired, this parameter will change to "True"

Name	Range	Default	Description	
Password expired - Configurator	<ul style="list-style-type: none"> <li>False</li> <li>True</li> </ul>	-		
Password expired - Superuser	<ul style="list-style-type: none"> <li>False</li> <li>True</li> </ul>	-		
Default password unchanged - Operator	<ul style="list-style-type: none"> <li>False</li> <li>True</li> </ul>	-		
Default password unchanged - Configurator	<ul style="list-style-type: none"> <li>False</li> <li>True</li> </ul>	-		Indicates if the user level is using the default password or a user configured password.
Default password unchanged - Superuser	<ul style="list-style-type: none"> <li>False</li> <li>True</li> </ul>	-		
Password last changed - Operator	DD/MM/YYYY HH:mm:ss	-		
Password last changed - Configurator	DD/MM/YYYY HH:mm:ss	-		
Password last changed - Superuser	DD/MM/YYYY HH:mm:ss	-		

## 5 Communication

### 5.1 Connections menu

"Connections" menu is found under "Communication" menu. It contains all basic settings of the default back panel ethernet port and RS-485 serial port as well as settings of communication option cards.

Table. 5.1 - 186. Ethernet settings.

Name	Range	Description
IP address	0.0.0.0...255.255.255.255	Set IP address of the ethernet port in the back of the device.
Netmask	0.0.0.0...255.255.255.255	Set netmask of the ethernet port in the back of the device.
Gateway	0.0.0.0...255.255.255.255	Set gateway of the ethernet port in the back of the device.
MAC-Address	00-00-00-00-00-00...FF-FF-FF-FF-FF-FF	Indication of MAC address of the device.
Storm Protection	<ul style="list-style-type: none"> <li>• Disable</li> <li>• Enable</li> </ul>	When enabled, the Storm protection functionality of the internal switch in the device is enabled. This functionality aims to protect the device from excess ethernet traffic caused by storm situation. When enabled, the packet rate allowed to pass through on the ingress port towards the device, is limited to 150 packets per second. Multicast packets are also included in the packet limit.
Double Ethernet card mode	<ul style="list-style-type: none"> <li>• Switch</li> <li>• HSR</li> <li>• PRP</li> </ul>	If the device has a double ethernet option card it is possible to choose its mode.
COM A and Ethernet option card connection	<ul style="list-style-type: none"> <li>• Block all</li> <li>• Allow both directions</li> <li>• Allow COM A to option card</li> <li>• Allow option card to COM A</li> </ul>	If the device has ethernet option card it is possible to determine the allowed direction of data.
Double Ethernet link events	<ul style="list-style-type: none"> <li>• Disable</li> <li>• Enable</li> </ul>	Disables or enables "Double Ethernet Link A down" and "Double Ethernet Link B down" logic signals and events.
Double Ethernet PRP ports	<ul style="list-style-type: none"> <li>• AB</li> <li>• BA</li> </ul>	LanA and LanB port assignment for communication cards that support PRP.

Table. 5.1 - 187. Ethernet security settings.

Name	Description
Enable back Ethernet port	Enable/Disable back panel Ethernet port communication.
Enable front Ethernet port	Enable/Disable front panel Ethernet port communication.

Name	Description
Enable SSH from front Ethernet port	Enable/Disable front panel Ethernet port SSH.
Enable FTP	Enable/Disable FTP server.
Enable discovery messages	Enable/Disable discovery messages. Discovery messages enable <i>Tools</i> → <i>Device list</i> menu in AQtivate setting tool to find all of the devices in the network.
Enable script running	Enable/Disable running scripts with <i>Tools</i> → <i>Run script</i> in AQtivate setting tool.

Virtual Ethernet enables the device to be connected to multiple different networks simultaneously via one physical Ethernet connection. Virtual Ethernet has its own separate IP address and network configurations. All Ethernet-based protocol servers listen for client connections on the IP addresses of both the physical Ethernet and the Virtual Ethernet.

Table. 5.1 - 188. Virtual Ethernet settings.

Name	Description
Enable virtual adapter (No / Yes)	Enable virtual adapter. Off by default.
IP address	Set IP address of the virtual adapter.
Netmask	Set netmask of the virtual adapter.
Gateway	Set gateway of the virtual adapter.

Table. 5.1 - 189. Ethernet Option Card settings.

Name	Range	Default	Description
Ethernet card type	<ul style="list-style-type: none"> <li>None</li> <li>SFP</li> <li>RJ45</li> </ul>	Ready only	Indicates the ethernet card type.
Card mode	<ul style="list-style-type: none"> <li>COM A IP</li> <li>Single virtual IP</li> <li>Dual virtual IP</li> </ul>	COM A IP	
Rate limit	<ul style="list-style-type: none"> <li>No limit</li> <li>12.5Mb/1Mb</li> <li>30Mb/2Mb</li> </ul>	No limit	
Clock synchronization mode	<ul style="list-style-type: none"> <li>IRIG-B</li> <li>PTP</li> </ul>	IRIG-B	Clock synchronization mode selection. See " <a href="#">Time synchronization</a> " chapter for more information.
Card status	<ul style="list-style-type: none"> <li>Port1 link ok</li> <li>Port2 link ok</li> </ul>	Read only	
Card status (all)	0...4294967295	Read only	
Port 1 dropped packet count	0...4294967295	Read only	

Name	Range	Default	Description
Port 2 dropped packet count	0...4294967295	Read only	
Enable port 1	<ul style="list-style-type: none"> <li>No</li> <li>Yes</li> </ul>	No	
Port 1 SFP module status	<ul style="list-style-type: none"> <li>Error</li> <li>OK</li> </ul>	Read only	
Port1 virtual Ethernet adapter IP address	0.0.0.0...255.255.255.255	10.15.1.0	
Port1 virtual Ethernet adapter netmask	0.0.0.0...255.255.255.255	255.255.255.0	
Port1 virtual Ethernet adapter gateway	0.0.0.0...255.255.255.255	10.15.1.254	
Port1 virtual Ethernet adapter MAC address	00-00-00-00-00-00...FF-FF-FF-FF-FF-FF	Read only	
Port 1 allowed protocols	<ul style="list-style-type: none"> <li>IEC61850</li> <li>GOOSE</li> <li>ModbusTCP</li> <li>IEC104</li> <li>DNP TCP</li> <li>FTP</li> <li>OPC UA</li> <li>NTP</li> <li>LPM communication</li> <li>Settingtool communication</li> <li>PTP</li> </ul>	None	
Port 1 link status events	<ul style="list-style-type: none"> <li>Enable</li> <li>Disable</li> </ul>	Enable	
Port 2 SFP module status	<ul style="list-style-type: none"> <li>Error</li> <li>OK</li> </ul>	Read only	
Port 2 link status events	<ul style="list-style-type: none"> <li>Enable</li> <li>Disable</li> </ul>	Enable	

The device is equipped with an RS-485 serial port. In the software it is identified as "Serial COM1" port.

Table. 5.1 - 190. Serial COM1 settings.

Name	Range	Description
Bitrate	<ul style="list-style-type: none"> <li>9600bps</li> <li>19200bps</li> <li>38400bps</li> </ul>	Bitrate used by RS-485 port.

Name	Range	Description
Databits	7...8	Databits used by RS-485 port.
Parity	<ul style="list-style-type: none"> <li>• None</li> <li>• Even</li> <li>• Odd</li> </ul>	Paritybits used by RS-485 port.
Stopbits	1...2	Stopbits used by RS-485 port.
Protocol	<ul style="list-style-type: none"> <li>• None</li> <li>• ModbusRTU</li> <li>• ModbusIO</li> <li>• IEC103</li> <li>• SPA</li> <li>• DNP3</li> <li>• IEC101</li> </ul>	Communication protocol used by RS-485 port.

The device supports communication option card type that has serial fiber ports (Serial COM2) an RS-232 port (Serial COM3).

Table. 5.1 - 191. Serial COM2 settings.

Name	Range	Description
Bitrate	<ul style="list-style-type: none"> <li>• 9600bps</li> <li>• 19200bps</li> <li>• 38400bps</li> </ul>	Bitrate used by serial fiber channels.
Databits	7...8	Databits used by serial fiber channels.
Parity	<ul style="list-style-type: none"> <li>• None</li> <li>• Even</li> <li>• Odd</li> </ul>	Paritybits used by serial fiber channels.
Stopbits	1...2	Stopbits used by serial fiber channels.
Protocol	<ul style="list-style-type: none"> <li>• None</li> <li>• ModbusRTU</li> <li>• ModbusIO</li> <li>• IEC103</li> <li>• SPA</li> <li>• DNP3</li> <li>• IEC101</li> </ul>	Communication protocol used by serial fiber channels.
Echo	<ul style="list-style-type: none"> <li>• Off</li> <li>• On</li> </ul>	Enable or disable echo.
Idle Light	<ul style="list-style-type: none"> <li>• Off</li> <li>• On</li> </ul>	Idle light behaviour.

Table. 5.1 - 192. Serial COM3 settings.

Name	Range	Description
Bitrate	<ul style="list-style-type: none"> <li>9600bps</li> <li>19200bps</li> <li>38400bps</li> </ul>	Bitrate used by RS-232 port.
Databits	7...8	Databits used by RS-232 port.
Parity	<ul style="list-style-type: none"> <li>None</li> <li>Even</li> <li>Odd</li> </ul>	Paritybits used by RS-232 port.
Stopbits	1...2	Stopbits used by RS-232 port.
Protocol	<ul style="list-style-type: none"> <li>None</li> <li>ModbusRTU</li> <li>ModbusIO</li> <li>IEC103</li> <li>SPA</li> <li>DNP3</li> <li>IEC101</li> </ul>	Communication protocol used by RS-232 port.

## 5.2 Time synchronization

Time synchronization source can be selected with "Time synchronization" parameter at *Communication* → *Synchronization* → *General*.

Table. 5.2 - 193. General time synchronization source settings.

Name	Range	Description
Time synchronization source	<ul style="list-style-type: none"> <li>Internal</li> <li>External NTP</li> <li>External serial</li> <li>IRIG-B</li> <li>PTP</li> </ul>	Selection of time synchronization source.

### 5.2.1 Internal

If no external time synchronization source is available the mode should be set to "internal". This means that the device clock runs completely on its own. Time can be set to the device with AQtivate setting tool with *Commands* → *Sync Time* command or in the clock view from the HMI. When using *Sync time* command AQtivate sets the time to device the connected computer is currently using. Please note that the clock doesn't run when the device is powered off.

### 5.2.2 NTP

When enabled, the NTP (Network Time Protocol) service can use external time sources to synchronize the device's system time. The NTP client service uses an Ethernet connection to connect to the NTP time server. NTP can be enabled by setting the primary time server and the secondary time server parameters to the address of the system's NTP time source(s).

Table. 5.2.2 - 194. Server settings.

Name	Range	Description
Primary time server address	0.0.0.0...255.255.255.255	Defines the address of the primary NTP server. Setting this parameter at "0.0.0.0" means that the server is not in use.
Secondary time server address	0.0.0.0...255.255.255.255	Defines the address of the secondary (or backup) NTP server. Setting this parameter at "0.0.0.0" means that the server is not in use.
NTP version	3...4	Defines the NTP version used.

Table. 5.2.2 - 195. Status.

Name	Range	Description
NTP quality for events	<ul style="list-style-type: none"> <li>No sync</li> <li>Synchronized</li> </ul>	Displays the status of the NTP time synchronization at the moment. <b>NOTE:</b> This indication is not valid if another time synchronization method is used (external serial).
NTP-processed message count	0...4294967295	Displays the number of messages processed by the NTP protocol.

Additionally, the time zone of the device can be set by connecting to the device and the selecting the time zone at *Commands* → *Set time zone* in AQtivate setting tool.

### 5.2.3 PTP

The device supports IEEE 1588v2 precision time protocol synchronization in accordance with the PTP profiles defined in IEEE C37.238-2011/2017 and IEC 61850-9-3 (2016). The device can be configured to operate as a master, as a slave or in an automatic mode where the role is selected dynamically.

In typical operation the device functions as an ordinary clock and is configured either in slave mode or in auto mode. In both cases the device synchronizes to an external Grandmaster and does not normally act as a time source when a higher-priority clock is available. This is common in networks where a GPS-synchronized Grandmaster is present.

When operating in auto mode the device participates in the Best Master Clock Algorithm (BMCA) continuously comparing its clock quality with other PTP devices in the network. Based on this evaluation it automatically assumes the appropriate role—either master or slave.

When the device is explicitly configured in master mode it behaves as a pre-master if a GPS-synchronized Grandmaster is present. In this condition it advertises its clock properties but does not take over the Grandmaster role unless the higher-priority clock becomes unavailable.

To ensure redundancy at least one device often a protection relay is typically assigned a higher priority or explicitly set to master to act as a backup Grandmaster. If the GPS-synchronized master becomes unavailable this device takes over seamlessly and continuous time distribution.

If the device becomes a Grandmaster either because it is explicitly configured as master or because BMCA selects it in auto mode it provides the reference time for other devices. In this state the device is not synchronized to GPS and the time source relies solely on its internal oscillator. This ensures continued synchronization within the network even when the GPS-based master is lost although the absolute accuracy depends on the internal clock stability.

## Settings

Select PTP as the time synchronization source from *Communication* → *Synchronization* → *General* menu.

The following settings are available in *Communication* → *Synchronization* → *PTP* menu.

Table. 5.2.3 - 196. PTP time synchronization settings.

Name	Range	Description
Power profile	<ul style="list-style-type: none"> <li>None</li> <li>IEEE C37-238-2011</li> <li>IEC61850-9-3</li> <li>IEEE C37-238-2017</li> </ul>	Defines used power profile.
Role	<ul style="list-style-type: none"> <li>Auto (Default)</li> <li>Master</li> <li>Slave</li> </ul>	In Auto mode, the device can take both the role of a clock source and clock consumer. In Master mode the device is forced to consider itself to be a clock source. In Slave mode the device is forced to be a clock consumer.
Mechanism	<ul style="list-style-type: none"> <li>P2P (Default)</li> <li>E2E</li> </ul>	Delay measurement mechanism used. Peer-to-peer can utilize the PTP enabled switches as transparent to boundary clocks while End-to-end must be used if non-PTP enabled switches are found in the network.
Domain number	0...255	PTP devices can be set to belong to a grouping called domain. Devices in same domain is primarily being synchronized together.
Log announce interval		Mean time interval between successive announce messages.
Log delayReq interval		The minimum permitted mean time interval between successive Delay_Req messages
Log sync interval		Mean time interval between successive sync messages
Sync receipt timeout		Number of sync intervals that must pass without receipt of an sync message before the occurrence of the event SYNC_RECEIPT_TIMEOUT_EXPIRES
Announce receipt timeout		Number of announce intervals that must pass without receipt of an announce message before the occurrence of the event ANNOUNCE_RECEIPT_TIMEOUT_EXPIRES
Clock class		The traceability, synchronization state and expected performance of the time or frequency distributed by the Grandmaster PTP Instance
Clock accuracy		The expected accuracy of a PTP Instance when it is the Grandmaster PTP Instance, or in the event it becomes the Grandmaster PTP Instance
Priority 1		Priority setting used in the execution of the best master clock algorithm. Lower values take precedence
Priority 2		Priority setting used in the execution of the best master clock algorithm. Lower values take precedence

Name	Range	Description
VLAN enable	<ul style="list-style-type: none"> <li>Disabled</li> <li>Enabled</li> </ul>	Enable VLAN header for PTP communication
VLAN priority	0...7	Priority setting for VLAN
VLAN ID	0...4095	VLAN identification setting
Reconfigure PTP	<ul style="list-style-type: none"> <li>-</li> <li>Reconfigure</li> </ul>	Parameter to trig reconfiguration of the PTP application

## Status indications

The following status indications are available in *Communication* → *Synchronization* → *PTP* menu.

Table. 5.2.3 - 197. PTP status indications

Name	Description
State	State of the PTP application (Master, Slave, Listening).
Best master	Identification of best master in network. Id consist of MAC address plus id number.
Last receive	Time when last synchronization frame was received.
Message sent	Diagnostic message counter.
Message receive	Diagnostic message counter.
PTP timesource	Diagnostic number describing the current time source.

## 5.3 Communication protocols

The following chapters will describe all available communication protocols. The device includes an RJ-45 ethernet port and an RS-485 serial port, which are able to use communication protocols. See other options for communication ports under "[Construction and installation](#)".

### 5.3.1 IEC 61850

The user can enable the IEC 61850 protocol in device models that support this protocol at *Communication* → *Protocols* → *IEC61850*. The device supports both Edition 1 and 2 of IEC 61850. The following services are supported by the device:

- Up to eight (8) data sets
- Report Control Blocks (both buffered and unbuffered reporting)
- Control ('Direct operate with normal security', 'Select before operate with normal security', 'Direct with enhanced security' and 'Select before operate with enhanced security' control sequences)
- Disturbance recording file transfer
- GOOSE
- Time synchronization

The device's current IEC 61850 setup can be viewed and edited with the IEC61850 tool (*Tools* → *Communication* → *IEC 61850*).

## Settings

The general setting parameters for the IEC 61850 protocol are visible both in AQtivate and in the local HMI. The settings are described in the table below.

Table. 5.3.1 - 198. General settings.

Name	Range	Step	Default	Description
Enable IEC 61850	<ul style="list-style-type: none"> <li>Disabled</li> <li>Enabled</li> </ul>	-	Disabled	Enables and disables the IEC 61850 communication protocol.
Reconfigure IEC 61850	<ul style="list-style-type: none"> <li>-</li> <li>Reconfigure</li> </ul>	-	-	Reconfigures IEC 61850 settings.
IEC61850 edition	<ul style="list-style-type: none"> <li>Ed1</li> <li>Ed2</li> </ul>	-	-	Displays the IEC61850 edition used by the device. Edition can be chosen by loading a new CID file at <i>Tools</i> → <i>Communication</i> → <i>IEC 61850</i> with <i>Open</i> button.
Control Authority switch	<ul style="list-style-type: none"> <li>Remote Control</li> <li>Station Level Control</li> </ul>	-	Remote Control	The device can be set to allow object control via IEC 61850 only from clients that are of category Station level control. This would mean that other Remote control clients would not be allowed to control. In Remote control mode all IEC 61850 clients of both remote and station level category are allowed to control objects.
Ethernet port	<ul style="list-style-type: none"> <li>All</li> <li>COM A</li> <li>Double ethernet card</li> </ul>	-	All	Determines which ports use IEC61850. Parameter is visible if double ethernet option card is found in the device.
Configure GOOSE Subscriber from CID file allowed	<ul style="list-style-type: none"> <li>Disabled</li> <li>Allowed</li> </ul>	-	Disabled	In edition 2 of IEC 61850 GOOSE subscriber configuration is a part of the CID file. Determines if it is possible to import published GOOSE settings of another device with a CID file and set them to GOOSE input at <i>Tools</i> → <i>Communication</i> → <i>IEC 61850</i> → <i>GOOSE subscriptions</i> .
General deadband	0.1...10.0 %	0.1 %	2 %	Determines the general data reporting deadband settings.
Active energy deadband	0.1...1000.0 kWh	0.1 kWh	2 kWh	Determines the data reporting deadband settings for this measurement.
Reactive energy deadband	0.1...1000.0 kVar	0.1 kVar	2 kVar	Determines the data reporting deadband settings for this measurement.
Active power deadband	0.1...1000.0 kW	0.1 kW	2 kW	Determines the data reporting deadband settings for this measurement.
Reactive power deadband	0.1...1000.0 kVar	0.1 kVar	2 kVar	Determines the data reporting deadband settings for this measurement.
Apparent power deadband	0.1...1000.0 kVA	0.1 kVA	2 kVA	Determines the data reporting deadband settings for this measurement.

Name	Range	Step	Default	Description
Power factor deadband	0.01...0.99	0.01	0.05	Determines the data reporting deadband settings for this measurement.
Frequency deadband	0.01...1.00 Hz	0.01 Hz	0.1 Hz	Determines the data reporting deadband settings for this measurement.
Current deadband	0.01...50.00 A	0.01 A	5 A	Determines the data reporting deadband settings for this measurement.
Residual current deadband	0.01...50.00 A	0.01 A	0.2 A	Determines the data reporting deadband settings for this measurement.
Voltage deadband	0.01...5000.00 V	0.01 V	200 V	Determines the data reporting deadband settings for this measurement.
Residual voltage deadband	0.01...5000.00 V	0.01 V	200 V	Determines the data reporting deadband settings for this measurement.
Angle measurement deadband	0.1...5.0 deg	0.1 deg	1 deg	Determines the data reporting deadband settings for this measurement.
mA deadband	0.01...5.00 mA	0.01 mA	0.10 mA	Determines the data reporting deadband settings for this measurement.
Integration time	0...10 000 ms	1 ms	0 ms	Determines the integration time of the protocol. If this parameter is set to "0 ms", no integration time is in use. See chapter " <a href="#">Integration time</a> " for more information.
GOOSE Ethernet port	<ul style="list-style-type: none"> <li>All</li> <li>COM A</li> <li>Double ethernet card</li> </ul>	-	All	Determines which ports can use GOOSE communication. Visible if double ethernet option card is found in the device.

For more information on the IEC 61850 communication protocol support, please refer to the conformance statement documents (<https://www.arcteq.com/documents-and-software/> → AQ 200 series → Resources).

### 5.3.1.1 Logical device mode and logical node mode

Every protection block has its own behavior (LNBeh). This behavior is determined using a combination of the protection block's mode (LNMod) and the device's mode (LDMod).

In IEC61850 mode,

- LNMod can be reported and controlled through Mod data object in all logical nodes.
- LNBeh can be reported through Beh data object in all logical nodes.
- LDMod is only visible through logical node zero's Mod data object (LLN0.Mod).

#### Mode and behavior values

There are 5 values defined for mode and behavior: On, Blocked, Test, Test / Blocked and Off.

Table. 5.3.1.1 - 199. Behavior descriptions.

LNBeh	On	Blocked	Test	Test / Blocked	Off
Function working	Yes	Yes	Yes	Yes	No
Data quality	Relevant to data	Relevant to data	q.test = True	q.test = True	q.validity = Invalid
Output to process	Yes	No	Yes	No	No
Accept normal control	Yes	Yes	No	No	No
Accept test control	No	No	Yes	Yes	No

The communication services for the **data object Mod** do not care about the status of the LNBeh. Mod will always accept commands with **q.test = False**.

**Data objects Mod, Beh and Health** will always have **q.validity = Good**. Regardless of the status of LNBeh, the quality test attribute of Mod, Beh and Health shall be **q.test = False**.

### Behavior determination

The values for LDMod and LNMod are settable by the user by using HMI, setting tool, or IEC 61850 client. The value for LNBeh are then determined using following rules.

- If either LDMod or LNMod is Off, LNBeh is Off.
- Otherwise,
  - If either LDMod or LNMod is set to either "Test" or "Test / Blocked" mode, LNBeh is in Test mode.
  - If either LDMod or LNMod is set to either "Blocked" or "Test / Blocked" mode, LNBeh is in Blocked mode.
  - If LNBeh still doesn't have anything, LNBeh is "On".

All the possible combinations are laid out in the following table.

Table. 5.3.1.1 - 200. All possible logical device and logical node combinations.

LDMod	LNMod	LNBeh
Off	Off	Off
	Test / Blocked	Off
	Test	Off
	Blocked	Off
	On	Off
Test / Blocked	Off	Off
	Test / Blocked	Test / Blocked
	Test	Test / Blocked
	Blocked	Test / Blocked
	On	Test / Blocked

LMod	LNMod	LNBeh
Test	Off	Off
	Test / Blocked	Test / Blocked
	Test	Test
	Blocked	Test / Blocked
	On	Test
Blocked	Off	Off
	Test / Blocked	Test / Blocked
	Test	Test / Blocked
	Blocked	Blocked
	On	Blocked
On	Off	Off
	Test / Blocked	Test / Blocked
	Test	Test
	Blocked	Blocked
	On	On

### Processing of incoming data in different behaviors

This part only applies to incoming data with quality information.

The table below gives the functional processing of the data in different behavior states **as defined by the standard**. Logical nodes should process receiving data according to their quality information:

- Processed as valid - Reacts according to the quality.
- Processed as invalid - Reacts as if the quality of the data had been invalid.
- Processed as questionable - The application decides how to consider the status value.
- Not processed - Do not belong to communication services, no quality bit can be evaluated.

Table. 5.3.1.1 - 201. Processing of incoming data in different behaviors as defined by the standard.

	On	Blocked	Test	Test / Blocked	Off
q.validity = Good q.test = False	Processed as valid	Processed as valid	Processed as valid	Processed as valid	Not processed
q.validity = Questionable q.test = False	Processed as questionable	Processed as questionable	Processed as questionable	Processed as questionable	Not processed
q.validity = Good q.test = True	Processed as invalid	Processed as invalid	Processed as valid	Processed as valid	Not processed

	On	Blocked	Test	Test / Blocked	Off
q.validity = Questionable q.test = True	Processed as invalid	Processed as invalid	Processed as questionable	Processed as questionable	Not processed
q.validity = Invalid q.test = True/ False	Processed as invalid	Processed as invalid	Processed as invalid	Processed as invalid	Not processed

Arcteq's implementation treats "Processed as questionable" and "Processed as invalid" in the same way with "Not processed". Only "Processed as valid" is passed to the application.

Table. 5.3.1.1 - 202. Arcteq's implementation of processing of incoming data in different behaviors.

	On	Blocked	Test	Test / Blocked	Off
q.validity = Good q.test = False	Processed as valid	Processed as valid	Processed as valid	Processed as valid	
q.validity = Questionable q.test = False					
q.validity = Good q.test = True			Processed as valid	Processed as valid	
q.validity = Questionable q.test = True					
q.validity = Invalid q.test = True/False					

## Using mode and behavior

Enabling LDMod and LNMod changing can be done at *General* → *Device info*.

Table. 5.3.1.1 - 203. Parameters to allow changing of LNMod and LDMod.

Name	Range	Default	Description
Allow setting of device mode	<ul style="list-style-type: none"> <li>Prohibited</li> <li>From HMI/setting tool only</li> <li>Allowed</li> </ul>	Prohibited	<p>Allows global mode to be modified from setting tool, HMI and IEC61850.</p> <p>Prohibited: Cannot be changed.</p> <p>From HMI/setting tool only: Can only be changed from the setting tool or HMI.</p> <p>Allowed: Can be changed from the setting tool, HMI, and IEC 61850 client.</p>

Name	Range	Default	Description
Allow setting of individual LN mode	<ul style="list-style-type: none"> <li>• Prohibited</li> <li>• From HMI/setting tool only</li> <li>• Allowed</li> </ul>	Prohibited	<p>Allow local modes to be modified from setting tool, HMI and IEC61850.</p> <p>This parameter is visible only when "Allow setting of device mode" is enabled.</p> <p>Prohibited: Cannot be changed.</p> <p>From HMI/setting tool only: Can only be changed from the setting tool or HMI</p> <p>Allowed: Can be changed from the setting tool, HMI, and IEC 61850 client.</p>

When enabled it is possible to change LDMod at *Communication* → *Protocols* → *IEC61850*.

Table. 5.3.1.1 - 204. Parameter for changing logical device mode.

Name	Range	Default	Description
Allow setting of device mode	<ul style="list-style-type: none"> <li>• On</li> <li>• Blocked</li> <li>• Test</li> <li>• Test/Blocked</li> <li>• Off</li> </ul>	On	<p>Set mode of logical device.</p> <p>This parameter is visible only when <i>Allow setting of device mode</i> is enabled in <i>General</i> menu.</p>

Each protection, control and monitoring function has its own logical node mode which can be changed individually. This parameter is found in the functions *Info*-menu. Each function also reports its behavior. Behavior of the function is influenced by the status of the device mode setting and the functions mode setting.

Table. 5.3.1.1 - 205. LNMod parameters.

Name	Range	Default	Description
LN mode	<ul style="list-style-type: none"> <li>• On</li> <li>• Blocked</li> <li>• Test</li> <li>• Test/Blocked</li> <li>• Off</li> </ul>	On	<p>Set mode of function logical node.</p> <p>This parameter is visible only when <i>Allow setting of individual LN mode</i> is enabled in <i>General</i> menu.</p>
LN behavior	<ul style="list-style-type: none"> <li>• On</li> <li>• Blocked</li> <li>• Test</li> <li>• Test/Blocked</li> <li>• Off</li> </ul>	On	<p>Displays the mode of the function logical node.</p> <p>This parameter is visible only when <i>Allow setting of individual LN mode</i> is enabled in <i>General</i> menu.</p>

### 5.3.1.2 GOOSE

Arcteq devices support both GOOSE publisher and GOOSE subscriber. GOOSE subscriber is enabled with the "GOOSE subscriber enable" parameter at *Communication* → *Protocols* → *IEC 61850/GOOSE*. The GOOSE inputs are configured using either the local HMI or the AQtivate software.

There are up to 64 GOOSE inputs available for use. Each of the GOOSE inputs also has a corresponding input quality signal which can also be used in internal logic. The quality is good, when the input quality status is "low" (that is, when the quality is marked as "0"). The value of the input quality can switch on as a result of a GOOSE time-out or a configuration error, for example. The status and quality of the various logical input signals can be viewed at the *GOOSE IN status* and *GOOSE IN quality* tabs at *Control* → *Device I/O* → *Logical signals*.

## General GOOSE setting

The table below presents general settings for GOOSE publisher.

Table. 5.3.1.2 - 206. General GOOSE publisher settings.

Name	Range	Description
GOOSE control block 1 simulation bit	<ul style="list-style-type: none"> <li>Disabled (Default)</li> <li>Enabled</li> </ul>	The publisher will publish frames with simulation bit active if enabled. For GOOSE simulation testing purposes.
GOOSE control block 2 simulation bit		

The table below presents general settings for GOOSE subscriber

Table. 5.3.1.2 - 207. General GOOSE subscriber settings.

Name	Range	Description
GOOSE subscriber enable	<ul style="list-style-type: none"> <li>Disabled (Default)</li> <li>Enabled</li> </ul>	Enables or disables GOOSE subscribing for the device.
Not used GOOSE input Quality	<ul style="list-style-type: none"> <li>Bad quality (1)</li> <li>Good quality (0)</li> </ul>	Defines what state should GOOSE input quality signal to be in the logic if the input has been set as "disabled".
Subscriber checks GoCRef	<ul style="list-style-type: none"> <li>No (Default)</li> <li>Yes</li> </ul>	When subscriber sees GOOSE frame it checks APPID and Conf. Rev but can also check if GoCRef or SqNum match.
Subscriber checks SqNum		
Subscriber process simulation messages	<ul style="list-style-type: none"> <li>No (Default)</li> <li>Yes</li> </ul>	Subscriber can be set to process frames which are published with simulation bit high if enabled. The subscriber can still subscribe to non-simulated frames from a publisher until that a simulated frame is received from a publisher. From that point on, only simulated frames are accepted from that publisher. For other publishers, non-simulated frames are accepted normally (given no simulated frame is received from that publisher). This behavior ends when the setting is set back to No.

## GOOSE input settings

The table below presents the different settings available for all 64 GOOSE inputs.

These settings can be found from *Communication* → *Protocols* → *IEC61850/GOOSE* → *GOOSE Input Settings*.

Table. 5.3.1.2 - 208. GOOSE input settings.

Name	Range	Description
In use	<ul style="list-style-type: none"> <li>No (Default)</li> <li>Yes</li> </ul>	Enables and disables the GOOSE input in question.
Application ID ("AppID")	0x0...0x3FFF	Defines the application ID that will be matched with the publisher's GOOSE control block.
Configuration revision ("ConfRev")	1...2 <sup>32</sup> -1	Defines the configuration revision that will be matched with the publisher's GOOSE control block.
Data index ("DataIdx")	0...99	Defines the data index of the value in the matched published frame. It is the status of the GOOSE input.
NextIdx is quality	<ul style="list-style-type: none"> <li>No (Default)</li> <li>Yes</li> </ul>	Selects whether or not the next received input is the quality bit of the GOOSE input.
Data type	<ul style="list-style-type: none"> <li>Boolean (Default)</li> <li>Integer</li> <li>Unsigned</li> <li>Floating point</li> </ul>	Selects the data type of the GOOSE input.
Control block reference	-	GOOSE subscriber can be set to check the GCB reference of the published GOOSE frame. This setting is automatically filled when Ed2 GOOSE configuration is done by importing cid file of the publisher.

## GOOSE input descriptions

Each of the GOOSE inputs can be given a description. The user defined description are displayed in most of the menus:

- logic editor
- matrix
- block settings
- event history
- disturbance recordings
- etc.

These settings can be found from *Control* → *Device IO* → *Logical Signals* → *GOOSE IN Description*.

Table. 5.3.1.2 - 209. GOOSE input user description.

Name	Range	Default	Description
User editable description GI x	1...31 characters	GOOSE IN x	Description of the GOOSE input. This description is used in several menu types for easier identification.

## GOOSE input values

Each of the GOOSE subscriber inputs (1...64) have indications listed in the following table. These indications can be found from *Communication* → *Protocols* → *IEC61850/GOOSE* → *GOOSE input values*.

Table. 5.3.1.2 - 210. GOOSE input indications

Name	Range	Description
Subscription status	<ul style="list-style-type: none"> <li>Not Active</li> <li>Active</li> </ul>	When active correct data received and passed to application.
Processing simulation message	<ul style="list-style-type: none"> <li>False</li> <li>True</li> </ul>	When true subscriber is processing simulation frames for this input (and rejecting non-simulated frames).
Needs commissioning	<ul style="list-style-type: none"> <li>False</li> <li>True</li> </ul>	When true configuration doesn't match the received frame (goCRef, confRev).
Last received state number	0...4294967295	Status number (stNum) of the last data passed to application.
GOOSE IN X boolean value	0...1	GOOSE input 1...64 boolean value.
GOOSE IN X analog value	-3.4E+38...3.4E+38	GOOSE input 1...64 analog value.
GOOSE IN X quality	<ul style="list-style-type: none"> <li>Old data</li> <li>Failure</li> <li>Oscillatory</li> <li>Bad reference</li> <li>Out of range</li> <li>Overflow</li> <li>Invalid</li> <li>Reserved/ Questionable</li> <li>Operator blocked</li> <li>Test</li> <li>Substituted</li> <li>Inaccurate</li> <li>Inconsistent</li> </ul>	GOOSE input quality indication.
GOOSE IN X time	DD/MM/YYYY HH:MM:SS	Time when publisher sent GOOSE frame.
GOOSE IN X time fraction	0...4294967295 μs	Microseconds of the publisher GOOSE frame.

## GOOSE events

GOOSE signals generate events from status changes. The user can select which event messages are stored in the main event buffer: ON, OFF, or both. The events triggered by the function are recorded with a time stamp and with process data values. The time stamp resolution is 1 ms.

Table. 5.3.1.2 - 211. GOOSE event

Event block name	Event name	Description
GOOSE1...GOOSE2	GOOSE IN 1...64 ON/OFF	Status change of GOOSE input.
GOOSE3...GOOSE4	GOOSE IN 1...64 quality Bad/Good	Status change of GOOSE inputs quality.
GOOSE5...GOOSE6	GOOSE Subscription status 1...64 Active/Not active	When active correct data received and passed to application.
GOOSE7...GOOSE8	GOOSE Processing simulated messages 1...64 True/False	When true subscriber is processing simulation frames for this input (and rejecting non-simulated frames).
GOOSE9...GOOSE10	GOOSE Subscription needs commissioning 1...64 True/False	When true configuration doesn't match the received frame (goCBRef, confRev).

### Setting the publisher

The configuration of the GOOSE publisher is done using the IEC 61850 tool in AQtivate (*Tools* → *Communication* → *IEC 61850*). Refer to *AQtivate-200 Instruction manual* for more information on how to set up GOOSE publisher.

## 5.3.2 Modbus TCP and Modbus RTU

The device supports both Modbus TCP and Modbus RTU communication. Modbus TCP uses the Ethernet connection to communicate with Modbus TCP clients. Modbus RTU is a serial protocol that can be selected for the available serial ports.

The user can enable the Modbus TCP protocol at *Communication* → *Protocols* → *Modbus TCP*. The user can enable the Modbus RTU protocol at *Communication* → *Connections*.

The following Modbus function types are supported:

- Read multiple holding registers (function code 3)
- Write single holding register (function code 6)
- Write multiple holding registers (function code 16)
- Read/Write multiple registers (function code 23)

The following data can be accessed using both Modbus TCP and Modbus RTU:

- Device measurements
- Device I/O
- Commands
- Events
- Time

Once the configuration file has been loaded, the user can access the Modbus map of the device via the AQtivate software (*Tools* → *Communication* → *Modbus Map*). Please note that holding registers start from 1. Some masters might begin numbering holding register from 0 instead of 1; this will cause an offset of 1 between the device and the master. Modbus map can be edited with Modbus Configurator (*Tools* → *Communication* → *Modbus Configurator*).

Table. 5.3.2 - 212. Modbus TCP settings.

Parameter	Range	Description
Enable Modbus TCP	<ul style="list-style-type: none"> <li>Disabled</li> <li>Enabled</li> </ul>	Enables and disables the Modbus TCP on the Ethernet port.
IP port	0...65 535	Defines the IP port used by Modbus TCP. The standard port (and the default setting) is 502.
Ethernet port	<ul style="list-style-type: none"> <li>All</li> <li>COM A</li> <li>Double Ethernet card</li> </ul>	Defines which ethernet ports are available for Modbus connection. Visible if any double ethernet option card is installed in the device.
Event read mode	<ul style="list-style-type: none"> <li>Get oldest available</li> <li>Continue previous connection</li> <li>New events only</li> </ul>	Get oldest event possible (Default) Continue with the event idx from previous connection Get only new events from connection time and forward.

Table. 5.3.2 - 213. Modbus RTU settings.

Parameter	Range	Description
Slave address	1...247	Defines the Modbus RTU slave address for the unit.

## Reading events

Modbus protocol does not support time-stamped events by standard definition. This means that every vendor must come up with their own definition how to transfer events from the device to the client. Events can be read from HR17...HR22 holding registers. HR17 contains the event-code, HR18...20 contains the time-stamp in UTC, HR21 contains a sequential index and HR22 is reserved for future expansion. See the Modbus Map for more information. The event-codes and their meaning can be found from Event list (*Tools* → *Events ang Logs* → *Event list* in setting tool). The event-code in HR17 is 0 if no new events can be found in the device event-buffer. Every time HR17 is read from client the event in event-buffer is consumed and on following read operation the next un-read event information can be found from event registers. HR11...HR16 registers contains a back-up of last read event. This is because some users want to double-check that no events were lost

### 5.3.3 IEC 103

IEC 103 is the shortened form of the international standard IEC 60870-5-103. The device is able to run as a secondary (slave) station. The IEC 103 protocol can be selected for the serial ports that are available in the device. A primary (master) station can then communicate with the device and receive information by polling from the slave device. The transfer of disturbance recordings is not supported.

The user can enable the IEC 103 protocol at *Communication* → *Connections*.

**NOTE:** Once the configuration file has been loaded, the IEC 103 map of the device can be found in the AQtivate software (*Tools* → *IEC 103 map*).

Table. 5.3.3 - 214. IEC 103 settings.

Name	Range	Step	Default	Description
Slave address	1...254	1	1	Defines the IEC 103 slave address for the unit.
Measurement interval	0...60 000 ms	1 ms	2000 ms	Defines the interval for the measurements update.

The following table presents the setting parameters for the IEC 103 protocol.

### 5.3.4 IEC 101/104

The standards IEC 60870-5-101 and IEC 60870-5-104 are closely related. Both are derived from the IEC 60870-5 standard. On the physical layer the IEC 101 protocol uses serial communication whereas the IEC 104 protocol uses Ethernet communication. The IEC 101/104 implementation works as a slave in the unbalanced mode.

For detailed information please refer to the IEC 101/104 interoperability document (<https://www.arcteq.com/documents-and-software/> → AQ-200 series → Resources → "AQ-200 IEC101 & IEC104 interoperability").

The user can enable the IEC104 protocol at *Communication* → *Protocols* → *IEC101/104*. The user can enable the IEC101 protocol at *Communication* → *Connections*.

#### IEC 101 settings

Table. 5.3.4 - 215. IEC 101 settings.

Name	Range	Step	Default	Description
Common address of ASDU	0...65 534	1	1	Defines the common address of the application service data unit (ASDU) for the IEC 101 communication protocol.
Common address of ASDU size	1...2	1	2	Defines the size of the common address of ASDU.
Link layer address	0...65 534	1	1	Defines the address for the link layer.
Link layer address size	1...2	1	2	Defines the address size of the link layer.
Information object address size	2...3	1	3	Defines the address size of the information object.
Cause of transmission size	1...2	1	2	Defines the cause of transmission size.

## IEC101/104 measurement scaling coefficients

Table. 5.3.4 - 216. Measurement scaling coefficient settings.

Name	Range	Default	Description
General scaling coef.	<ul style="list-style-type: none"> <li>• No scaling</li> <li>• 1/10</li> <li>• 1/100</li> <li>• 1/1000</li> <li>• 1/10000</li> <li>• 1/100000</li> <li>• 1/1000000</li> <li>• 10</li> <li>• 100</li> <li>• 1000</li> <li>• 10000</li> <li>• 100000</li> <li>• 1000000</li> </ul>	No scaling	Optional scaling factor for IEC101/IEC104 communication. Values from 1/10 to 1/1,000,000 apply a division to the measurement. Values from 10 to 1,000,000 apply a multiplication to the measurement.
Active energy scaling coef.			
Reactive energy scaling coef.			
Active power scaling coef.			
Reactive power scaling coef.			
Apparent power scaling coef.			
Power factor scaling coef.			
Frequency scaling coef.			
Current scaling coef.			
Residual current scaling coef.			
Voltage scaling coef.			
Residual voltage scaling coef.			
Angle measurement scaling coef.			
mA scaling coef.			

## IEC101/104 deadband settings

Table. 5.3.4 - 217. Analog change deadband settings.

Name	Range	Step	Default	Description
General deadband	0.1...10.0%	0.1%	2%	Determines the general data reporting deadband settings.
Active energy deadband	0.1...1000.0kWh	0.1kWh	2kWh	Determines the data reporting deadband settings for this measurement.
Reactive energy deadband	0.1...1000.0kVar	0.1kVar	2kVar	
Active power deadband	0.1...1000.0kW	0.1kW	2kW	

Name	Range	Step	Default	Description
Reactive power deadband	0.1...1000.0kVar	0.1kVar	2kVar	
Apparent power deadband	0.1...1000.0kVA	0.1kVA	2kVA	
Power factor deadband	0.01...0.99	0.01	0.05	
Frequency deadband	0.01...1.00Hz	0.01Hz	0.1Hz	
Current deadband	0.01...50.00A	0.01A	5A	
Residual current deadband	0.01...50.00A	0.01A	0.2A	
Voltage deadband	0.01...5000.00V	0.01V	200V	
Residual voltage deadband	0.01...5000.00V	0.01V	200V	
Angle measurement deadband	0.1...5.0deg	0.1deg	1deg	
mA measurement deadband	0.01...5.00 mA	0.01 mA	0.10 mA	
Integration time	0...10 000ms	1ms	-	Determines the integration time of the protocol. If this parameter is set to "0 ms", no integration time is in use. See chapter " <a href="#">Integration time</a> " for more information.

### 5.3.5 SPA

The device can act as a SPA slave. SPA can be selected as the communication protocol for the RS-485 port (Serial COM1). When the device has a serial option card, the SPA protocol can also be selected as the communication protocol for the serial fiber (Serial COM2) ports or RS-232 (Serial COM3) port. Please refer to the chapter "[Construction and installation](#)" in the device manual to see the connections for these modules.

The data transfer rate of SPA is 9600 bps, but it can also be set to 19 200 bps or 38 400 bps. As a slave the device sends data on demand or by sequenced polling. The available data can be measurements, circuit breaker states, function starts, function trips, etc. The full SPA signal map can be found in *AQtivate (Tools → SPA map)*.

The SPA event addresses can be found at *Tools → Events and logs → Event list*.

The user can enable the SPA protocol at *Communication → Connections*.

Table. 5.3.5 - 218. SPA setting parameters.

Name	Range	Description
SPA address	1...899	SPA slave address.
UTC time sync	<ul style="list-style-type: none"> <li>• Disabled</li> <li>• Enabled</li> </ul>	Determines if UTC time is used when synchronizing time. When disabled it is assumed time synchronization uses local time. If enabled it is assumed that UTC time is used. When UTC time is used the timezone must be set at <i>Commands</i> → <i>Set time zone</i> .

**NOTICE!**

To access SPA map and event list, an .aqs configuration file should be downloaded from the device.

### 5.3.6 DNP3

DNP3 is a protocol standard which is controlled by the DNP Users Group ([www.dnp.org](http://www.dnp.org)). The implementation of a DNP3 slave is compliant with the DNP3 subset (level) 2, but it also contains some functionalities of the higher levels. For detailed information please refer to the DNP3 Device Profile document (<https://www.arcteq.com/documents-and-software/> → AQ-200 series → Resources).

The user can enable the DNP3 TCP protocol at *Communication* → *Protocols* → *DNP3*. The user can enable the DNP3 serial protocol at *Communication* → *Connections*.

#### General settings

The following table describes the DNP3 setting parameters.

Table. 5.3.6 - 219. Settings.

Name	Range	Step	Default	Description
Enable DNP3 TCP	<ul style="list-style-type: none"> <li>• Disabled</li> <li>• Enabled</li> </ul>	-	Disabled	Enables and disables the DNP3 TCP communication protocol when the Ethernet port is used for DNP3. If a serial port is used, the DNP3 protocol can be enabled from <i>Communication</i> → <i>DNP3</i> .
IP port	0...65 535	1	20 000	Defines the IP port used by the protocol.
Ethernet port	<ul style="list-style-type: none"> <li>• All</li> <li>• COM A</li> <li>• Double Ethernet card</li> </ul>	-	All	Defines which ethernet ports are available for Modbus connection. Visible if any double ethernet option card is installed in the device.
Slave address	1...65 519	1	1	Defines the DNP3 slave address of the unit.
Master address	1...65 534	1	2	Defines the address for the allowed master.
Link layer time-out	0...60 000ms	1ms	0ms	Defines the length of the time-out for the link layer.
Link layer retries	1...20	1	1	Defines the number of retries for the link layer.

Name	Range	Step	Default	Description
Diagnostic - Error counter	0...2 <sup>32</sup> -1	1	-	Counts the total number of errors in received and sent messages.
Diagnostic - Transmitted messages	0...2 <sup>32</sup> -1	1	-	Counts the total number of transmitted messages.
Diagnostic - Received messages	0...2 <sup>32</sup> -1	1	-	Counts the total number of received messages.

## Default variations

Table. 5.3.6 - 220. Default variations.

Name	Range	Default	Description
Group 1 variation (BI)	<ul style="list-style-type: none"> <li>Var 1</li> <li>Var 2</li> </ul>	Var 1	Selects the variation of the binary signal.
Group 2 variation (BI change)	<ul style="list-style-type: none"> <li>Var 1</li> <li>Var 2</li> </ul>	Var 2	Selects the variation of the binary signal change.
Group 3 variation (DBI)	<ul style="list-style-type: none"> <li>Var 1</li> <li>Var 2</li> </ul>	Var 1	Selects the variation of the double point signal.
Group 4 variation (DBI change)	<ul style="list-style-type: none"> <li>Var 1</li> <li>Var 2</li> </ul>	Var 2	Selects the variation of the double point signal.
Group 20 variation (CNTR)	<ul style="list-style-type: none"> <li>Var 1</li> <li>Var 2</li> <li>Var 5</li> <li>Var 6</li> </ul>	Var 1	Selects the variation of the control signal.
Group 22 variation (CNTR change)	<ul style="list-style-type: none"> <li>Var 1</li> <li>Var 2</li> <li>Var 5</li> <li>Var 6</li> </ul>	Var 5	Selects the variation of the control signal change.
Group 30 variation (AI)	<ul style="list-style-type: none"> <li>Var 1</li> <li>Var 2</li> <li>Var 3</li> <li>Var 4</li> <li>Var 5</li> </ul>	Var 5	Selects the variation of the analog signal.
Group 32 variation (AI change)	<ul style="list-style-type: none"> <li>Var 1</li> <li>Var 2</li> <li>Var 3</li> <li>Var 4</li> <li>Var 5</li> <li>Var 7</li> </ul>	Var 5	Selects the variation of the analog signal change.

## DNP3 measurement scaling coefficients

Table. 5.3.6 - 221. Measurement scaling coefficient settings.

Name	Range	Default	Description
General scaling coef.	<ul style="list-style-type: none"> <li>• No scaling</li> <li>• 1/10</li> <li>• 1/100</li> <li>• 1/1000</li> <li>• 1/10000</li> <li>• 1/100000</li> <li>• 1/1000000</li> <li>• 10</li> <li>• 100</li> <li>• 1000</li> <li>• 10000</li> <li>• 100000</li> <li>• 1000000</li> </ul>	No scaling	Optional scaling factor for SPA communication. Values from 1/10 to 1/1,000,000 apply a division to the measurement. Values from 10 to 1,000,000 apply a multiplication to the measurement.
Active energy scaling coef.			
Reactive energy scaling coef.			
Active power scaling coef.			
Reactive power scaling coef.			
Apparent power scaling coef.			
Power factor scaling coef.			
Frequency scaling coef.			
Current scaling coef.			
Residual current scaling coef.			
Voltage scaling coef.			
Residual voltage scaling coef.			
Angle measurement scaling coef.			
mA scaling coef.			

## DNP3 deadband settings

Table. 5.3.6 - 222. Analog change deadband settings.

Name	Range	Step	Default	Description
General deadband	0.1...10.0%	0.1%	2%	Determines the general data reporting deadband settings.
Active energy deadband	0.1...1000.0kWh	0.1kWh	2kWh	Determines the data reporting deadband settings for this measurement.
Reactive energy deadband	0.1...1000.0kVar	0.1kVar	2kVar	
Active power deadband	0.1...1000.0kW	0.1kW	2kW	

Name	Range	Step	Default	Description
Reactive power deadband	0.1...1000.0kVar	0.1kVar	2kVar	
Apparent power deadband	0.1...1000.0kVA	0.1kVA	2kVA	
Power factor deadband	0.01...0.99	0.01	0.05	
Frequency deadband	0.01...1.00Hz	0.01Hz	0.1Hz	
Current deadband	0.01...50.00A	0.01A	5A	
Residual current deadband	0.01...50.00A	0.01A	0.2A	
Voltage deadband	0.01...5000.00V	0.01V	200V	
Residual voltage deadband	0.01...5000.00V	0.01V	200V	
Angle measurement deadband	0.1...5.0deg	0.1deg	1deg	
mA deadband	0.01...5.00 mA	0.01 mA	0.10 mA	
Integration time	0...10 000ms	1ms	0ms	Determines the integration time of the protocol. If this parameter is set to "0 ms", no integration time is in use. See chapter " <a href="#">Integration time</a> " for more information.

### 5.3.7 Modbus I/O

The Modbus I/O protocol can be selected to communicate on the available serial ports. The Modbus I/O is actually a Modbus/RTU master implementation that is dedicated to communicating with serial Modbus/RTU slaves such as RTD input modules. Up to three (3) Modbus/RTU slaves can be connected to the same bus polled by the Modbus I/O implementation. These are named I/O Module A, I/O Module B and I/O Module C. Each of the modules can be configured using parameters in the following two tables.

Table. 5.3.7 - 223. Module settings.

Name	Range	Description
I/O module X address	0...247	Defines the Modbus unit address for the selected I/O Module (A, B, or C). If this setting is set to "0", the selected module is not in use.
Module x type	<ul style="list-style-type: none"> <li>• ADAM-4018+</li> <li>• ADAM-4015</li> </ul>	Selects the module type.

Name	Range	Description
Channels in use	Channel 0...Channel 7 (or None)	Selects the number of channels to be used by the module.

Table. 5.3.7 - 224. Channel settings.

Name	Range	Step	Default	Description
Thermocouple type	<ul style="list-style-type: none"> <li>• +/- 20mA</li> <li>• 4...20mA</li> <li>• Type J</li> <li>• Type K</li> <li>• Type T</li> <li>• Type E</li> <li>• Type R</li> <li>• Type S</li> </ul>	-	4...20mA	Selects the thermocouple or the mA input connected to the I/O module. Types J, K, T and E are nickel-alloy thermocouples, while Types R and S are platinum/rhodium-alloy thermocouples.
Input value	-101.0...2000.0	0.1	-	Displays the input value of the selected channel.
Input status	<ul style="list-style-type: none"> <li>• Invalid</li> <li>• OK</li> </ul>	-	-	Displays the input status of the selected channel.

### 5.3.8 OPCUA

Table. 5.3.8 - 225. OPCUA settings.

Name	Range	Step	Default	Description
OPCUA mode	<ul style="list-style-type: none"> <li>• Disabled</li> <li>• Enabled</li> </ul>	-	Disabled	Enables or disables the OPCUA protocol.
OPCUA reconfigure	<ul style="list-style-type: none"> <li>• -</li> <li>• Reconfigure</li> </ul>	-	-	Reconfigures the OPCUA and takes the settings configured in <i>Tools</i> → <i>Communication</i> → <i>OPCUA</i> into use.
OPCUA Flat struct enable	<ul style="list-style-type: none"> <li>• Disabled</li> <li>• Enabled</li> </ul>	-	Disabled	

### 5.3.9 Integration time

When integration time is not used, measurement values are updated only when the change exceeds the configured deadband. If the deadband is set too low, measurements may be reported too frequently, creating unnecessary traffic. If the deadband is configured too high, the measurement may almost never update. When integration time is used, large changes are still reported quickly, but smaller changes are accumulated over time and eventually reported even if the deadband is not very sensitive.

With integration time enabled, the following parameters determine when a measurement is reported:

- deadband setting of the measurement
- integration time setting
- latest reported measurement value
- measured value.

An integrated value is calculated over time using these parameters. Once this integrated value exceeds the deadband, a new measurement update is sent.

Figure. 5.3.9 - 93. Integration time formula.

$$\text{Integrated value} = |\text{Measured value} - \text{Latest reported value}| * \left( \frac{t}{\text{Integration time}} \right)$$

Figure. 5.3.9 - 94. Example graph showing how integration time affects measurement reporting. Small changes take longer to increase the integrated value over the deadband setting (blue area). Big changes meet the deadband criteria faster (red area).

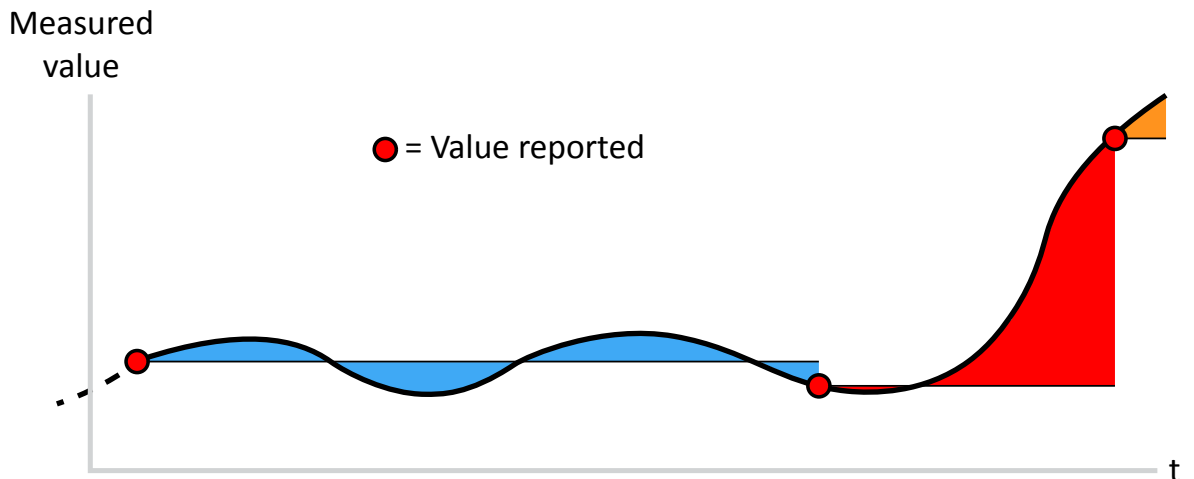

The time it takes for a value to be updated with the configured settings can be roughly estimated with the following formula:

Figure. 5.3.9 - 95. Measurement reporting delay when integration time is used.

$$t = \frac{\text{Deadband setting} * \text{Integration time setting}}{|\text{Measured value} - \text{Latest reported value}|}$$

If the latest reported value was 5.00 A and the measurement rises up to 6.00 A and stays stable, and the deadband setting for current is 2 A and the integration time setting is 1 s, we get the following result:

Figure. 5.3.9 - 96. Calculation example for estimating reporting time when integration time is in use.

$$t = \frac{2A * 1s}{|6A - 5A|} = 2s$$

## 5.4 Analog fault registers

At *Communication* → *General I/O* → *Analog fault registers* the user can set up to twelve (12) channels to record the measured value when a protection function starts or trips. These values can be read in two ways: locally from this same menu, or through a communication protocol if one is in use.

The following table presents the setting parameters available for the 12 channels.

Table. 5.4 - 226. Fault register settings.

Name	Range	Step	Default	Description
Select record source	Not in use I>, I>>, I>>>, I>>>> (IL1, IL2, IL3) Id>, Id>>, Id>>>, Id>>>> (IL1, IL2, IL3) IO>, IO>>, IO>>>, IO>>>> (IO) IOd>, IOd>>, IOd>>>, IOd>>>> (IO) FLX (Fault locator)	-	Not in use	Selects the protection function and its stage to be used as the source for the fault register recording. The user can choose between non-directional overcurrent, directional overcurrent, non-directional earth fault, directional earth fault, and fault locator functions.
Select record trigger	<ul style="list-style-type: none"> <li>• TRIP signal</li> <li>• START signal</li> <li>• START and TRIP signals</li> </ul>	-	TRIP signal	Selects what triggers the fault register recording: the selected function's TRIP signal, its START signal, or either one.
Recorded fault value	- 1000 000.00...1 000 000.00	0.01	-	Displays the recorded measurement value at the time of the selected fault register trigger.

### 5.5 Modbus Gateway

Figure. 5.5 - 97. Example setup of Modbus Gateway application.

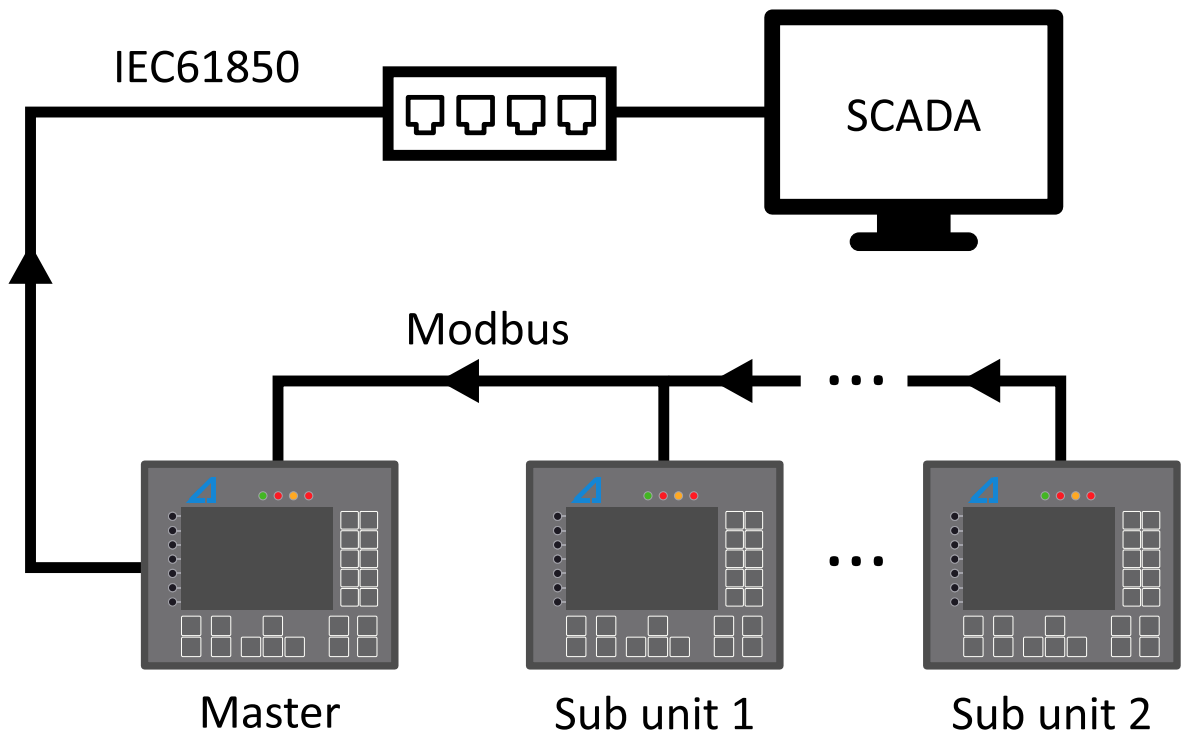

The device can be setup as a Modbus Gateway (i.e. master). Modbus Gateway device can import messages (measurements, status signals etc.) from external Arcteq and third-party devices. RS-485 serial communication port. Up to 32 sub units can be connected to a master unit. These messages can then be used for controlling logic in the master device, display the status in user created mimic. Binary signals can be reported forward to SCADA with IEC61850, IEC101, IEC103, IEC104, Modbus, DNP3 or SPA.

Modbus Gateway and its basic settings can be found from *Communication* → *Modbus Gateway*. General settings-menu displays the health of connection to each sub unit.

Table. 5.5 - 227. General settings

Name	Range	Description
Modbus Gateway mode	<ul style="list-style-type: none"> <li>Disabled (Default)</li> <li>Enabled</li> </ul>	Enables or disables Modbus Gateway.
Modbus Gateway reconfigure	- Reconfigure	Setting this parameter to "Reconfigure" takes new settings into use. Parameter returns back to "-" automatically.
Quality of Modbus Sub unit 1...32	<ul style="list-style-type: none"> <li>OK</li> <li>Old data</li> <li>Data questionable</li> <li>Modbus error</li> <li>Send fail</li> <li>Receive fail</li> </ul>	Quality of each connected sub unit.

## Imported signals

Modbus Gateway supports importing of measurements, bits, double bits, counters and integer signals. Up to 128 signals can be imported of each signal type with the exception of double bits (32).

Table. 5.5 - 228. Imported signals

Name	Range
Imported measurement 1-128	-3.4E+38...3.4E+38
Imported bit signal 1-128	0...1
Imported double bit data 1-32	0...3
Imported counter data 1-128	0...4294967295
Imported integer signal 1-128	-2147483648...2147483647

To assign the signals use Modbus Gateway editor (*Tools* → *Communication* → *Modbus Gateway*). Detailed description of this tool can be found in *AQtivate Instruction manual* (<https://www.arcteq.com/documents-and-software/>).

All imported signals can be given a description. The description will be displayed in most of menus with the signal (logic editor, matrix, block settings etc.).

Table. 5.5 - 229. Imported signal user description.

Name	Range	Default	Description
Describe measurement x	1...31 characters	Acq. Meas x	User settable description for the signal. This description is used in several menu types for easier identification.
Describe bit signal x		Acq. Bit x	
Describe double bit signal x		Acq. Binary x	
Describe counter signal x		Acq. Counter x	
Describe integer signal x		Acq. Integer x	

## Events

The Modbus Gateway generates events the status changes in imported bits and double bits. The user can select which event messages are stored in the main event buffer: ON, OFF, or both.

Table. 5.5 - 230. Event messages

Event block name	Event names
MGWB1	Bit 1...Bit 32 (ON, OFF)
MGWB2	Bit 33...Bit 64 (ON, OFF)
MGWB3	Bit 65...Bit 96 (ON, OFF)
MGWB4	Bit 97...Bit 128 (ON, OFF)
MGWD1	Double Bit 1... Double bit 16 (ON/ON, OFF/OFF, ON/OFF, OFF/ON)
MGWD2	Double Bit 17... Double bit 32 (ON/ON, OFF/OFF, ON/OFF, OFF/ON)

## 6 Connections and application examples

### 6.1 Connections of AQ-V251

Figure. 6.1 - 98. AQ-V251A application example with function block diagram.

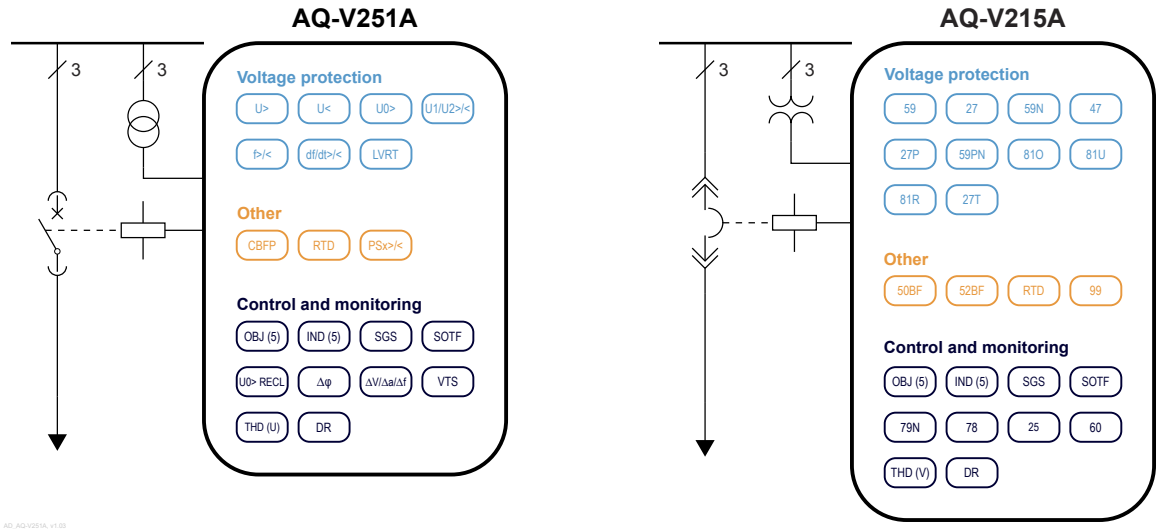
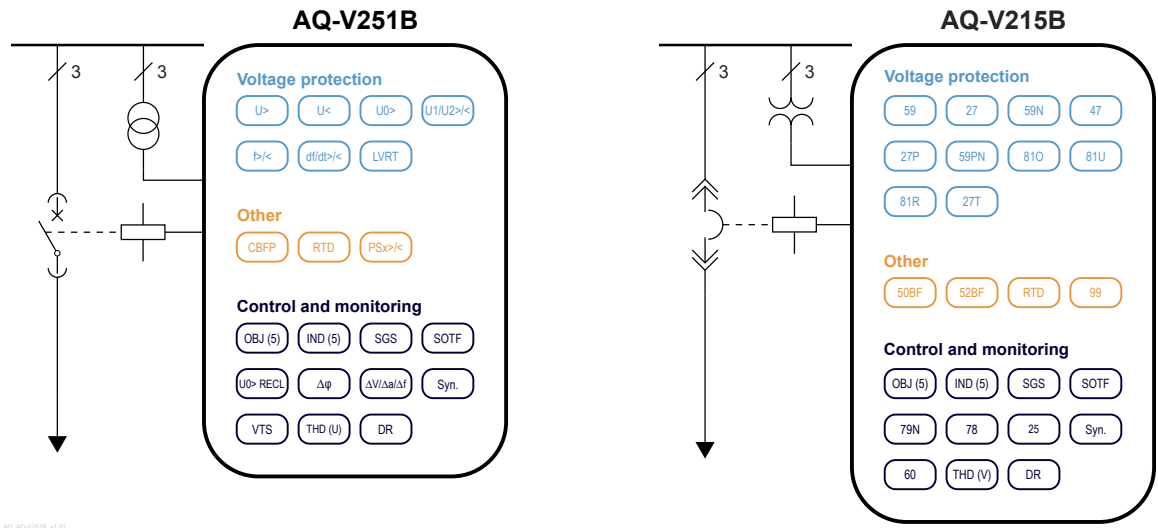

Figure. 6.1 - 99. AQ-V251B application example with function block diagram.



### 6.2 Application example and its connections

This chapter presents an application example for the voltage protection device.

Since three line-to-neutral voltages and the zero sequence voltage ( $U_4$ ) are connected, this application uses the voltage measurement mode "3LN+U0" (see the image below). The digital inputs are connected to indicate the breaker status, while the digital outputs are used for breaker control.

Figure. 6.2 - 100. Application example and its connections.

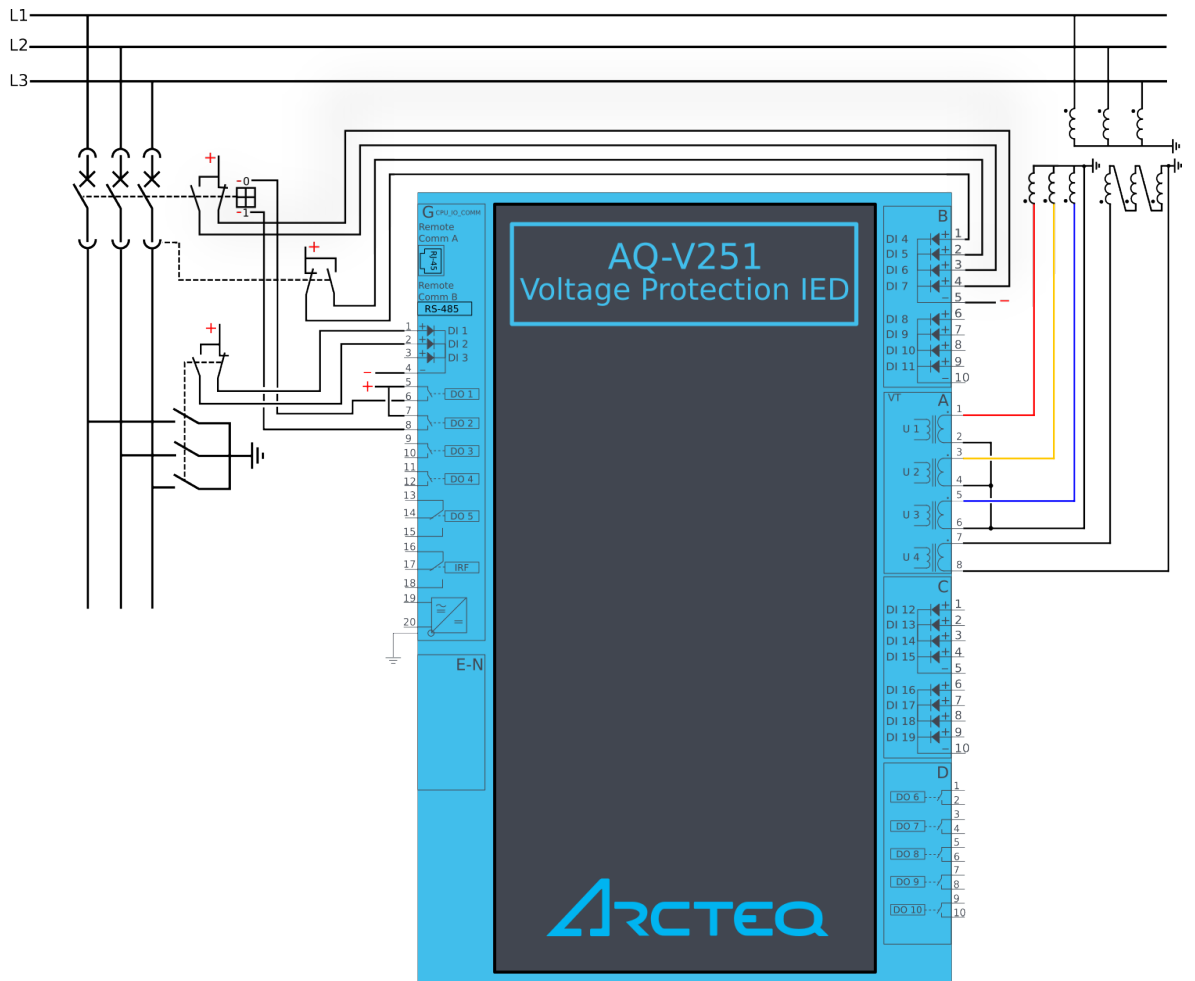

## 7 Construction and installation

### 7.1 Construction

AQ-X251 is a member of the modular and scalable AQ-200 series, and it includes thirteen (13) configurable and modular add-on card slots. As a standard configuration the device includes the CPU module (which consists of the CPU, a number of inputs and outputs, and the power supply) as well as one separate voltage measurement module.

The images below present the modules of both the non-optioned model (AQ-X251-XXXXXXX-AAAAAAAAAAAAA, on the left) and the fully optioned model (AQ-X251-XXXXXXX-BBBBBBBBBBCCJ, on the right).

Figure. 7.1 - 101. Modular construction of AQ-X251-XXXXXXX-AAAAAAAAAAAAA

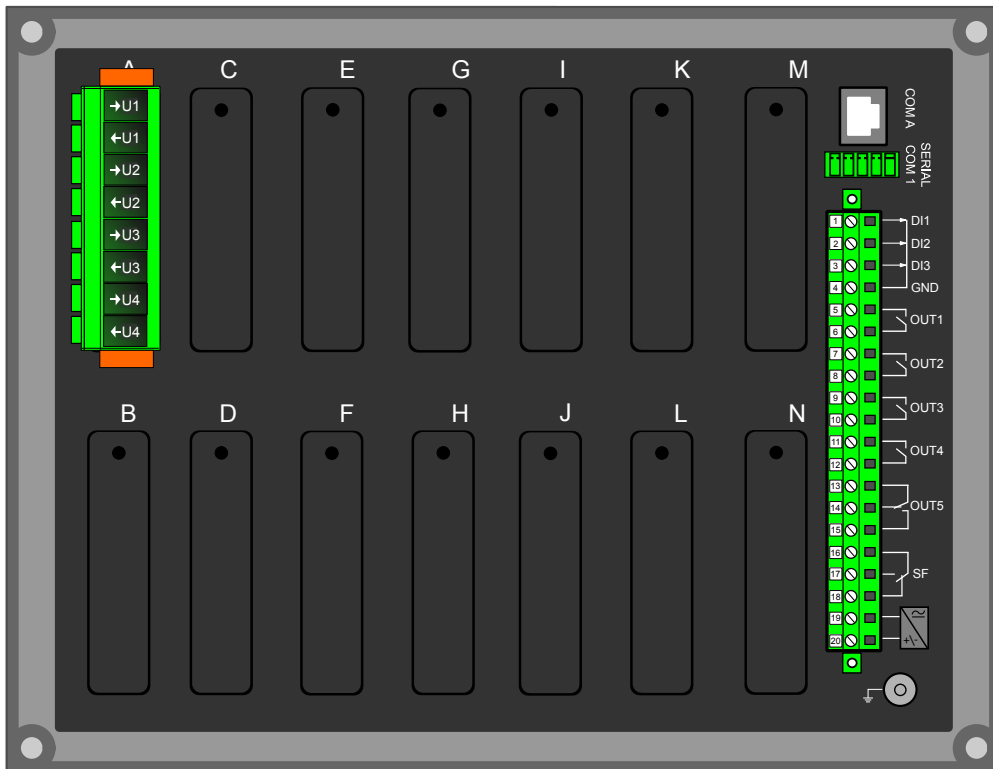
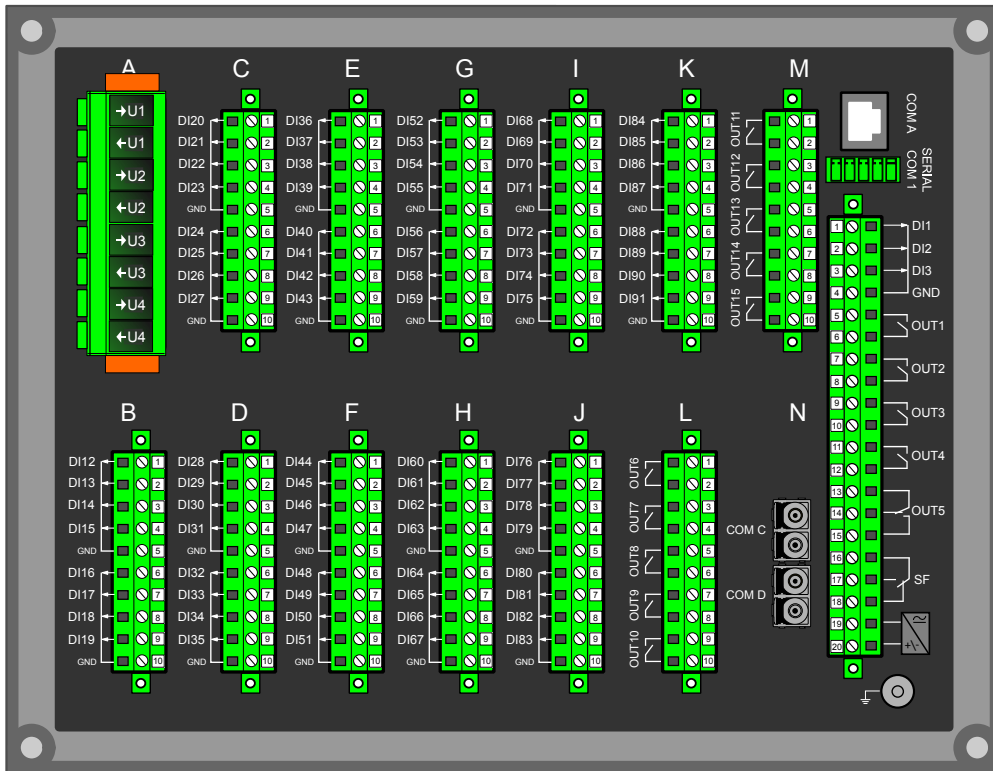

Figure. 7.1 - 102. Modular construction of AQ-X255-XXXXXX-BBBBBBBBBBCCJ



The modular structure of AQ-X251 allows for scalable solutions for different application requirements. In non-standard configurations slots from B to N accept all available add-on modules, such as digital I/O modules and other special modules. The only difference between the slots affecting device scalability is that Slots M and N also support communication options.

Start-up scan searches for modules according to their type designation code. If the module content is not what the device expects, the device issues a hardware configuration error message. In field upgrades, therefore, add-on modules must be ordered from Arcteq Relays Ltd. or its representative who can then provide the module with its corresponding unlocking code to allow the device to operate correctly once the hardware configuration has been upgraded.

When an I/O module is inserted into the device, the module location affects the naming of the I/O. The I/O scanning order in the start-up sequence is as follows: the CPU module I/O, Slot B, Slot C, Slot D, Slot E, Slot F and so on. This means that the digital input channels DI1, DI2 and DI3 as well as the digital output channels OUT1, OUT2, OUT3, OUT4 and OUT5 are always located in the CPU module. If additional I/O cards are installed, their location and card type affect the I/O naming.

The figure below presents the start-up hardware scan order of the device as well as the I/O naming principles.

Figure. 7.1 - 103. AQ-X251 hardware scanning and I/O naming principles.

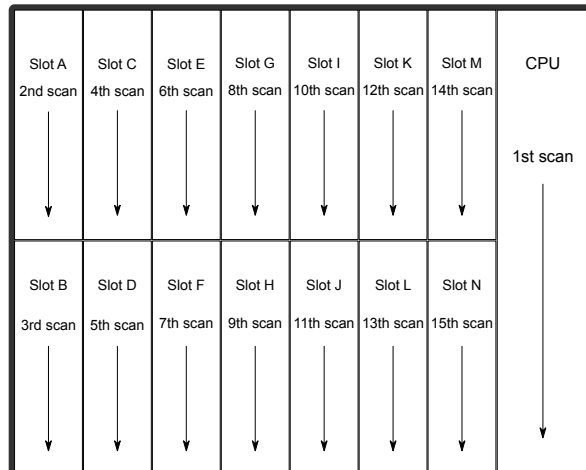

1. Scan  
The start-up system; detects and self-tests the CPU module, voltages, communication and the I/O; finds and assigns "DI1", "DI2", "DI3", "OUT1", "OUT2", "OUT3", "OUT4" and "OUT5".
2. Scan  
Scans Slot A and finds the four channels of the VT module (fixed for AQ-X251). If the VTM is not found, the device issues an alarm.
3. Scan  
Scans Slot B, and moves to the next slot if Slot B is empty. If the scan finds an 8DI module (that is, a module with eight digital inputs), it reserves the designations "DI4", "DI5", "DI6", "DI7", "DI8", "DI9", "DI10" and "DI11" to this slot. If the scan finds a DO5 module (that is, a module with five digital outputs), it reserves the designations "OUT6", "OUT7", "OUT8", "OUT9" and "OUT10" to this slot. The I/O is then added if the type designation code (e.g. AQ-P215-PH0AAAA-BBC) matches with the existing modules in the device. If the code and the modules do not match, the device issues and alarm. An alarm is also issued if the device expects to find a module here but does not find one.
4. Scan  
Scans Slot C, and moves to the next slot if Slot C is empty. If the scan finds an 8DI module, it reserves the designations "DI4", "DI5", "DI6", "DI7", "DI8", "DI9", "DI10" and "DI11" to this slot. If Slot B also has an 8DI module (and therefore has already reserved these designations), the device reserves the designations "DI12", "DI13", "DI14", "DI15", "DI16", "DI17", "DI18" and "DI19" to this slot. If the scan finds a 5DO module, it reserves the designations "OUT6", "OUT7", "OUT8", "OUT9" and "OUT10" to this slot. Again, if Slot B also has a 5DO and has therefore already reserved these designations, the device reserves the designations "OUT11", "OUT12", "OUT13", "OUT14" and "OUT15" to this slot.
5. – 15. Scan  
A similar operation to Scan 4 (checks which designations have been reserved by modules in previous slots and numbers the new ones accordingly).

The fully optioned example case of AQ-X251-XXXXXX-BBBBBBBBBBCCJ (the first image pair, on the right) has a total of 91 digital input channels available: three (DI1...DI3) in the CPU module, and the rest in Slots B...K in groups of eight. It also has a total of 15 digital output channels available: five (DO1...DO5) in the CPU module, and the rest in Slots L and M in groups of five. Additionally, there is a double (LC) fiber Ethernet communication option card installed in Slot N.

## 7.2 CPU module

Figure. 7.2 - 104. CPU module can be equipped with standard screw terminals or spring cage terminals for connection.

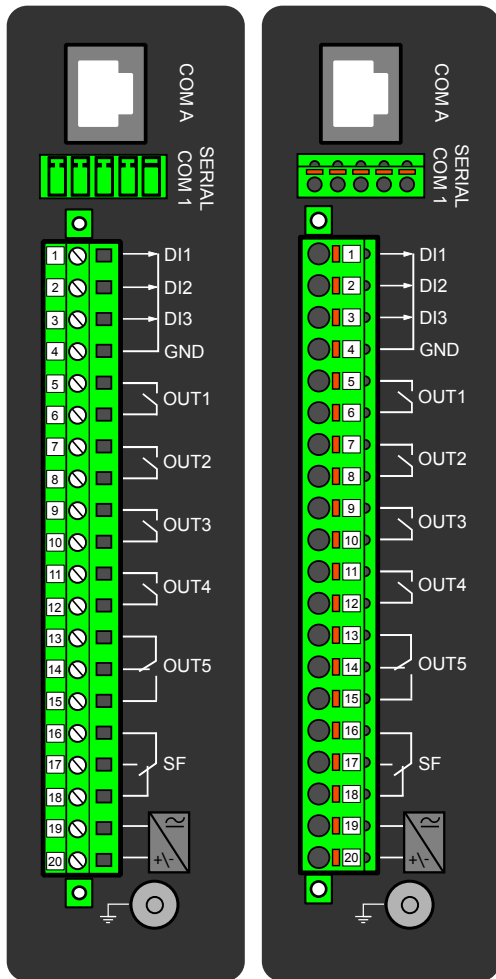

Connector	Description
COM A	Communication port A, or the RJ-45 port. Used for the setting tool connection and for SCADA communication.
COM B	Communication port B, or the RS-485 port. Used for SCADA communication. The pins have the following designations: <ul style="list-style-type: none"> <li>• Pin 1 = DATA +</li> <li>• Pin 2 = DATA -</li> <li>• Pin 3 = GND</li> <li>• Pins 4 &amp; 5 = Terminator resistor enabled by shorting.</li> </ul>
X1-1	Digital input 1, nominal threshold voltage 24 V, 110 V or 220 V.
X1-2	Digital input 2, nominal threshold voltage 24 V, 110 V or 220 V.
X1-3	Digital input 3, nominal threshold voltage 24 V, 110 V or 220 V.
X1-4	Common GND for digital inputs 1, 2 and 3.
X1-5:6	Output relay 1, with a normally open (NO) contact.

Connector	Description
X1-7:8	Output relay 2, with a normally open (NO) contact.
X1-9:10	Output relay 3, with a normally open (NO) contact.
X1-11:12	Output relay 4, with a normally open (NO) contact.
X1-13:14:15	Signaling relay 5, with a changeover contact. Not to be used in trip coil control.
X1-16:17:18	System fault's signaling relay, with a changeover contact. Pins 16 and 17 are closed when the unit has a system fault or is powered OFF. Pins 16 and 18 are closed when the unit is powered ON and there is no system fault.
X1-19:20	Power supply IN. Either 88...265 VAC/DC (model A; order code "H") or 18...75 DC (model B; order code "L"). <b>Positive side (+) to Pin 20.</b>
GND	The device's earthing connector.

By default, the CPU module (combining the CPU, the I/O and the power supply) includes two standard communication ports and the device's basic digital I/O.

The digital output controls can be set by the user with software. Digital outputs are controlled in 5 ms program cycles. All output contacts are mechanical. The rated voltage of the NO/NC outputs is 250 VAC/DC.

## Digital inputs

The current consumption of the digital inputs is 2 mA when activated. The range of the operating voltage is 24 V/110 V/220 V depending on the ordered hardware. All digital inputs are scanned in 5 ms program cycles.

The settings described in the table below can be found at *Control* → *Device I/O* → *Digital input settings* in the device settings.

Table. 7.2 - 231. Digital input settings.

Name	Range	Step	Default	Description
Dlx Polarity	<ul style="list-style-type: none"> <li>NO (Normally open)</li> <li>NC (Normally closed)</li> </ul>	-	NO	Selects whether the status of the digital input is 1 or 0 when the input is energized.
Dlx Activation delay	0.000...1800.000 s	0.001 s	0.000 s	Defines the delay for the status change from 0 to 1.
Dlx Drop-off time	0.000...1800.000 s	0.001 s	0.000 s	Defines the delay for the status change from 1 to 0.
Dlx AC mode	<ul style="list-style-type: none"> <li>Disabled</li> <li>Enabled</li> </ul>	-	Disabled	Selects whether or not a 30-ms deactivation delay is added to account for alternating current.

## Digital outputs

The digital output controls can be set by the user with software. Digital outputs are controlled in 5 ms program cycles. All output contacts are mechanical. The rated voltage of the NO/NC outputs is 250 VAC/DC.

Table. 7.2 - 232. Digital output settings.

Name	Range	Description
Out x Polarity	<ul style="list-style-type: none"> <li>• NO</li> <li>• NC</li> </ul>	<p>Determines the normal status of the output relay.</p> <p>Digital outputs are configured as “normally open” relays by default. Each output can be changed to “normally closed” using the “OUTx Polarity” parameter.</p> <p>Please note that this change is implemented in software only. If the device is powered off, the outputs will revert to an open state and return to the configured polarity once power is restored.</p> <p>If a truly “normally closed” contact is required, use the changeover relay OUT5 available in the CPU module of the device.</p> <p>An NC output signal does not open during a Communication or Protection reset.</p>

## Digital input and output descriptions

CPU card digital inputs and outputs can be given a description. The user defined description are displayed in most of the menus:

- logic editor
- matrix
- block settings
- event history
- disturbance recordings
- etc.

Table. 7.2 - 233. Digital input and output user description.

Name	Range	Default	Description
User editable description DIx	1...31 characters	DIx	Description of the digital input. This description is used in several menu types for easier identification.
User editable description OUTx		OUTx	Description of the digital output. This description is used in several menu types for easier identification.



### NOTICE!

After editing user descriptions the event history will start to use the new description only after resetting the HMI. HMI can be reset from *General* → *Device info* → *HMI restart*.

## Scanning cycle

All digital inputs are scanned in a 5 ms cycle, meaning that the state of an input is updated every 0...5 milliseconds. When an input is used internally in the device (either in setting group change or logic), it takes additional 0...5 milliseconds to operate. Theoretically, therefore, it takes 0...10 milliseconds to change the setting group when a digital input is used for group control or a similar function. In practice, however, the delay is between 2...8 milliseconds about 95 % of the time. When a digital input is connected directly to a digital output (OUT1...OUTx), it takes an additional 5 ms round. Therefore, when a digital input controls a digital output internally, it takes 0...15 milliseconds in theory and 2...13 milliseconds in practice.



### NOTICE!

The mechanical delay of the relay is not included in these approximations!

## 7.3 Voltage measurement module

Figure. 7.3 - 105. Voltage measurement module can be equipped with standard screw terminals or spring cage terminals for connection.

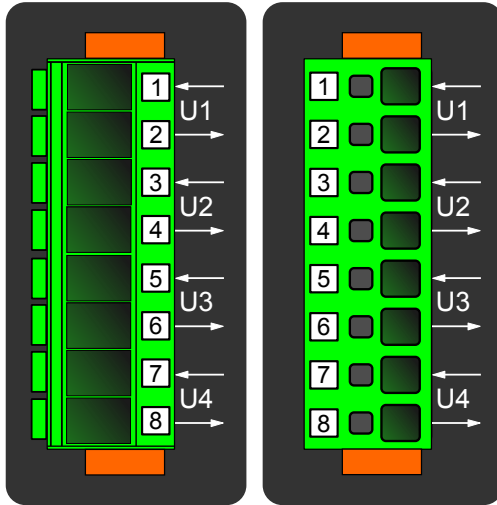

Connector	Description
VTM 1-2	Configurable voltage measurement input U1.
VTM 3-4	Configurable voltage measurement input U2.
VTM 5-6	Configurable voltage measurement input U3.
VTM 7-8	Configurable voltage measurement input U4.

A basic voltage measurement module with four channels includes four voltage measurement inputs that can be configured freely.

The voltage measurement module is connected to the secondary side of conventional voltage transformers (VTs) or directly to low-voltage systems secured by fuses. The nominal voltage can be set between 100...400 V. Voltages are calibrated in a range of 0...240 V, which provides  $\pm 0.2\%$  inaccuracy in the same range.

The voltage input characteristics are as follows:

- The measurement range is 0.5...480.0 V per channel.
- The angle measurement inaccuracy is less than  $\pm 0.5$  degrees within the nominal range.
- The frequency measurement range of the voltage inputs is 6...1800 Hz with standard hardware.
- The sample rate of the signal is 64 samples/cycle when the system frequency ranges from 6 Hz to 75 Hz.

For further details please refer to the "[Voltage measurement](#)" chapter in the "Technical data" section of this document.

## 7.4 Option cards

### 7.4.1 Digital input module (optional)

Figure. 7.4.1 - 106. Digital input module (DI8) with eight add-on digital inputs. Can be equipped with standard screw terminals or spring cage terminals for connection.

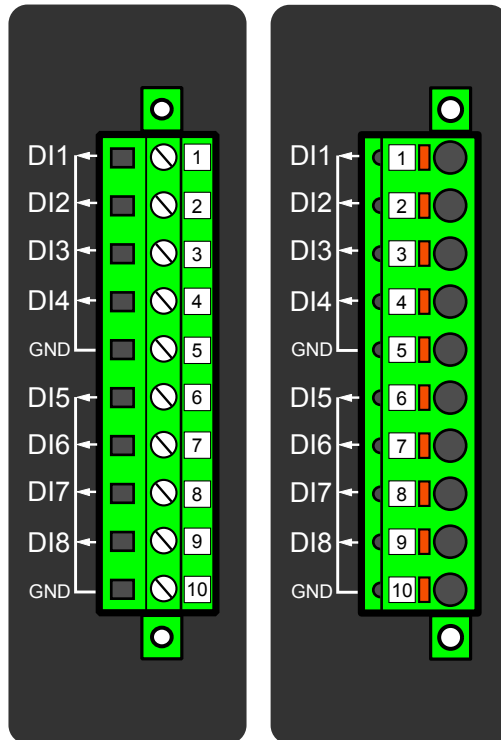

Connector	Description (x = the number of digital inputs in other modules that precede this one in the configuration)
X 1	DIx + 1
X 2	DIx + 2
X 3	DIx + 3
X 4	DIx + 4
X 5	Common earthing for the first four digital inputs.
X 6	DIx + 5
X 7	DIx + 6
X 8	DIx + 7
X 9	DIx + 8
X 10	Common earthing for the other four digital inputs.

The DI8 module is an add-on module with eight (8) galvanically isolated digital inputs. This module can be ordered directly to be installed into the device in the factory, or it can be upgraded in the field after the device's original installation when required. The properties of the inputs in this module are the same as those of the inputs in the main processor module. The current consumption of the digital inputs is 2 mA when activated, while the range of the operating voltage is from 0...265 VAC/DC. The activation and release thresholds are set in the software and the resolution is 1 V. All digital inputs are scanned in 5 ms program cycles, and their pick-up and release delays as well as their NO/NC selection can be set with software.

For the naming convention of the digital inputs provided by this module please refer to the chapter titled "[Construction and installation](#)".

For technical details please refer to the chapter titled "[Digital input module](#)" in the "Technical data" section of this document.

The hardware configuration code of this module is "B". For more information, please refer to the "[Ordering information](#)" chapter of this document.

### Setting up the activation and release delays

The settings described in the table below can be found at *Control* → *Device I/O* → *Digital input settings* in the device settings.

Table. 7.4.1 - 234. Digital input settings of DI8 module.

Name	Range	Step	Default	Description
Dlx Polarity	<ul style="list-style-type: none"> <li>NO (Normally open)</li> <li>NC (Normally closed)</li> </ul>	-	NO	Selects whether the status of the digital input is 1 or 0 when the input is energized.
Dlx Activation threshold	16.0...200.0 V	0.1 V	88 V	Defines the activation threshold for the digital input. When "NO" is the selected polarity, the measured voltage exceeding this setting activates the input. When "NC" is the selected polarity, the measured voltage exceeding this setting deactivates the input.
Dlx Release threshold	10.0...200.0 V	0.1 V	60V	Defines the release threshold for the digital input. When "NO" is the selected polarity, the measured voltage below this setting deactivates the input. When "NC" is the selected polarity, the measured voltage below this setting activates the input.
Dlx Activation delay	0.000...1800.000 s	0.001 s	0.000 s	Defines the delay when the status changes from 0 to 1. Not visible when DI has been set to AC mode with "Dlx AC mode" parameter.
Dlx Drop-off time	0.000...1800.000 s	0.001 s	0.000 s	Defines the delay when the status changes from 1 to 0.
Dlx AC Mode	<ul style="list-style-type: none"> <li>Disabled</li> <li>Enabled</li> </ul>	-	Disabled	Selects whether or not a 30-ms deactivation delay is added to take the alternating current into account. The "Dlx Release threshold" parameter is hidden and forced to 10 % of the set "Dlx Activation threshold" parameter.
Dlx Counter	0...2 <sup>32</sup> -1	1	0	Displays the number of times the digital input has changed its status from 0 to 1.

Name	Range	Step	Default	Description
Dlx Clear counter	<ul style="list-style-type: none"> <li>-</li> <li>Clear</li> </ul>	-	-	Resets the Dlx counter value to zero.

The user can set the activation threshold individually for each digital input. When the activation and release thresholds have been set properly, they will result in the digital input states to be activated and released reliably. The selection of the normal state between normally open (NO) and normally closed (NC) defines whether or not the digital input is considered activated when the digital input channel is energized.

The diagram below depicts the digital input states when the input channels are energized and de-energized.

Figure. 7.4.1 - 107. Digital input state when energizing and de-energizing the digital input channels.

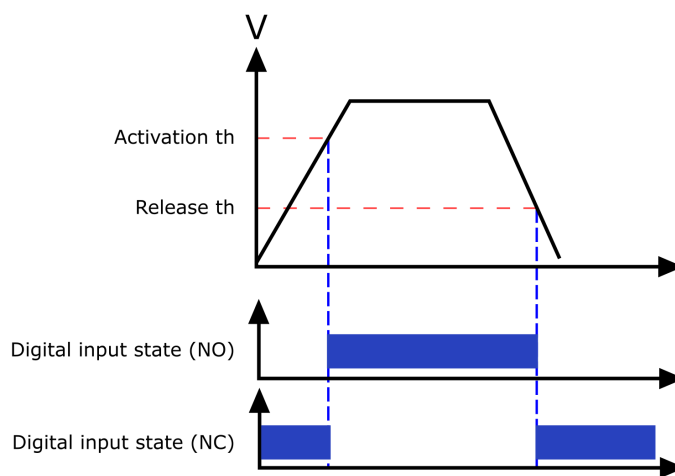

## Digital input descriptions

Option card inputs can be given a description. The user defined description are displayed in most of the menus:

- logic editor
- matrix
- block settings
- event history
- disturbance recordings
- etc.

Table. 7.4.1 - 235. Digital input user description.

Name	Range	Default	Description
User editable description Dlx	1...31 characters	Dlx	Description of the digital input. This description is used in several menu types for easier identification.



### NOTICE!

After editing user descriptions the event history will start to use the new description only after resetting the HMI. HMI can be reset from *General* → *Device info* → *HMI restart*.

## Digital input voltage measurements

Digital input option card channels measure voltage on each channel. The measured voltage can be seen at *Control* → *Device IO* → *Digital inputs* → *Digital input voltages*.

Table. 7.4.1 - 236. Digital input channel voltage measurement.

Name	Range	Step	Description
Dlx Voltage now	0.000...275.000 V	0.001 V	Voltage measurement of a digital input channel.

## 7.4.2 Digital output module (optional)

Figure. 7.4.2 - 108. Digital output module (DO5) with five add-on digital outputs. Can be equipped with standard screw terminals or spring cage terminals for connection.

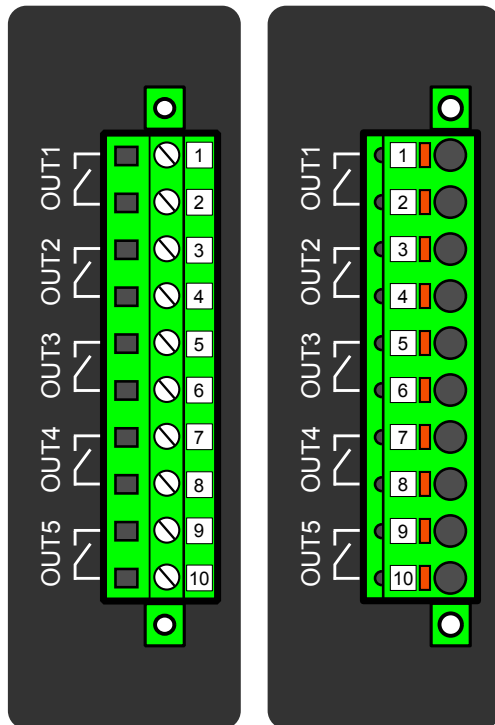

Connector	Description
X 1-2	OUTx + 1 (1 <sup>st</sup> and 2 <sup>nd</sup> pole NO)
X 3-4	OUTx + 2 (1 <sup>st</sup> and 2 <sup>nd</sup> pole NO)
X 5-6	OUTx + 3 (1 <sup>st</sup> and 2 <sup>nd</sup> pole NO)
X 7-8	OUTx + 4 (1 <sup>st</sup> and 2 <sup>nd</sup> pole NO)
X 9-10	OUTx + 5 (1 <sup>st</sup> and 2 <sup>nd</sup> pole NO)

The DO5 module is an add-on module with five (5) mechanical type digital outputs. This module can be ordered directly to be installed into the device in the factory, or it can be upgraded in the field after the device's original installation when required. The properties of the outputs in this module are the same as those of the outputs in the main processor module. Output control logic is user configurable. All digital outputs are controlled in 5 ms program cycles. The rated voltage of the outputs is 250 VAC/DC.

For the naming convention of the digital outputs provided by this module please refer to the chapter titled "[Construction and installation](#)".

For technical details please refer to the chapter titled "[Digital output module](#)" in the "Technical data" section of this document.

The hardware configuration code of this module is "C". For more information, please refer to the "[Ordering information](#)" chapter of this document.

## Digital output settings

The parameters described in the table below can be found at *Control* → *Device I/O* → *Digital Outputs* → *Digital Output Settings* in the device settings.

Table. 7.4.2 - 237. Digital output user description.

Name	Range	Default	Description
OUTx Polarity	<ul style="list-style-type: none"> <li>• NO</li> <li>• NC</li> </ul>	NO	<p>Digital outputs are configured as "normally open" relays by default. Each output can be changed to "normally closed" using the "OUTx Polarity" parameter. Please note that this change is implemented in software only. If the device is powered off, the outputs will revert to an open state and return to the configured polarity once power is restored.</p> <p>If a truly "normally closed" contact is required, use the changeover relay OUT5 available in the CPU module of the device.</p>

## Digital output descriptions

Option card outputs can be given a description. The user defined description are displayed in most of the menus:

- logic editor
- matrix
- block settings
- event history
- disturbance recordings
- etc.

The parameters described in the table below can be found at *Control* → *Device I/O* → *Digital Outputs* → *Digital Output Descriptions* in the device settings.

Table. 7.4.2 - 238. Digital output user description.

Name	Range	Default	Description
User editable description OUTx	1...31 characters	OUTx	Description of the digital output. This description is used in several menu types for easier identification.



**NOTICE!**

After editing user descriptions the event history will start to use the new description only after resetting the HMI. HMI can be reset from *General* → *Device info* → *HMI restart*.

### 7.4.3 High-speed and high-current output module (optional)

Figure. 7.4.3 - 109. High-speed and high-current output module with three add-on high-speed outputs. Can be equipped with standard screw terminals or spring cage terminals for connection.

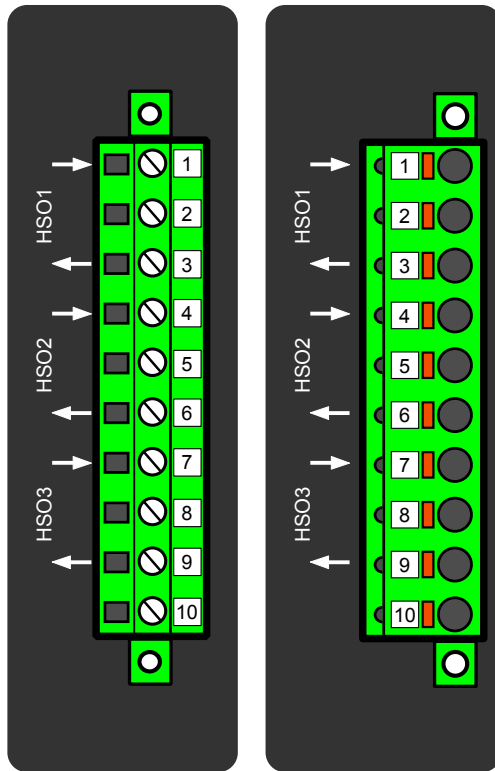

Connector	Description
X 1	HSOx + 1 in
X 2	N/A
X 3	HSOx + 1 out
X 4	HSOx + 2 in
X 5	N/A
X 6	HSOx + 2 out
X 7	HSOx + 3 in
X 8	N/A
X 9	HSOx + 3 out
X 10	N/A

The high-speed and high-current module is an add-on module with three (3) hybrid outputs consisting of a semiconductor and a relay connected in parallel. This module can be ordered directly to be installed into the device in the factory, or it can be upgraded in the field after the device's original installation when required. Output control logic is user configurable. All high-speed outputs are controlled in 1 ms program cycles.

For technical details please refer to the chapter titled "[High-speed output module](#)" in the "Technical data" section of this document.

The hardware configuration code of this module is "R". For more information, please refer to the "[Ordering information](#)" chapter of this document.

## HSO Input Settings menu

The parameters described in the table below can be found at *Control* → *Device I/O* → *HSO Inputs* → *HSO Input Settings* in the device settings.

Table. 7.4.3 - 239. HSO input parameters.

Name	Range	Step	Default	Description
HSO1...9 TCS Polarity	NC (Normally closed)	-	NC	The inputs on high-speed output cards are normally closed contacts, meaning they remain in the closed state under normal conditions and indicate '0' when the circuit is energized.
HSO1...9 TCS Drop-off time	0.000...1800.000 s	0.001 s	0.200 s	Defines the delay when the status changes from 0 to 1.
HSO1...9 TCS AC Mode	<ul style="list-style-type: none"> <li>Disabled</li> <li>Enabled</li> </ul>	-	Disabled	Selects whether or not a 30 ms deactivation delay is added to take the alternating current into account. The "Dlx Release threshold" parameter is hidden and forced to 10 % of the set "Dlx Activation threshold" parameter.
HSO1...9 TCS Counter	0...4294967295	1	0	Displays the number of times the input has changed its status from 0 to 1.
HSO1...9 TCS Clear counter	<ul style="list-style-type: none"> <li>-</li> <li>Clear</li> </ul>	-	-	Resets the input activation counter value to zero.

## HSO Output Settings menu

The parameters described in the table below can be found at *Control* → *Device I/O* → *HSO Outputs* → *HSO Output Settings* in the device settings.

Table. 7.4.3 - 240. HSO output parameters.

Name	Range	Step	Default	Description
HSO1...9 Polarity	<ul style="list-style-type: none"> <li>NO</li> <li>NC</li> </ul>	-	NO	The inputs on high-speed output cards are normally closed contacts, meaning they remain in the closed state under normal conditions and indicate '0' when the circuit is energized.

## HSO output and input descriptions

Option card outputs and inputs can be given a description. The user defined description are displayed in most of the menus:

- logic editor
- matrix
- block settings
- event history
- disturbance recordings
- etc.

Table. 7.4.3 - 241. HSO input and output user description.

Name	Range	Default	Description
User editable description HSOx	1...31 characters	HSOx	Description of the high-speed output. This description is used in several menu types for easier identification.
User editable description HSO1...9 TCS	1...31 characters	HSO1...9 TCS	Description of the high-speed output. This description is used in several menu types for easier identification.



### NOTICE!

After editing user descriptions the event history will start to use the new description only after resetting the HMI. HMI can be reset from *General* → *Device info* → *HMI restart*.

## 7.4.4 Milliampere output module (4x mA out & 1x mA in) (optional)

Figure. 7.4.4 - 110. Milliampere output (mA) I/O module connections. Can be equipped with standard screw terminals or spring cage terminals for connection.

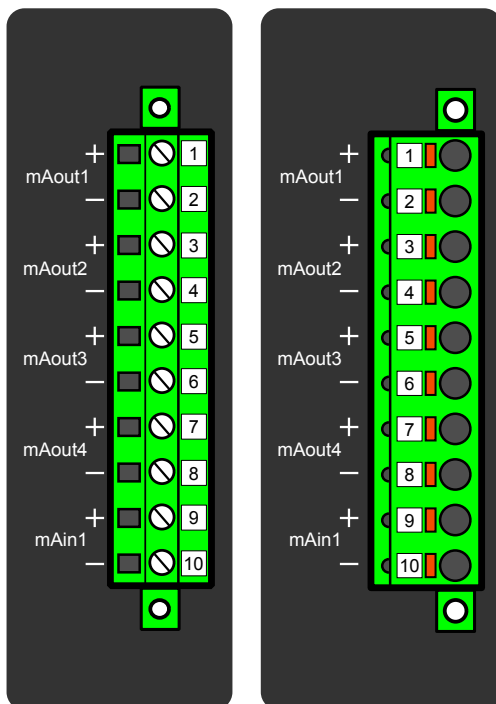

Connector	Description
Pin 1	mA OUT 1 + connector (0...24 mA)
Pin 2	mA OUT 1 – connector (0...24 mA)
Pin 3	mA OUT 2 + connector (0...24 mA)
Pin 4	mA OUT 2 – connector (0...24 mA)
Pin 5	mA OUT 3 + connector (0...24 mA)
Pin 6	mA OUT 3 – connector (0...24 mA)
Pin 7	mA OUT 4 + connector (0...24 mA)
Pin 8	mA OUT 4 – connector (0...24 mA)
Pin 9	mA IN 1 + connector (0...33 mA)
Pin 10	mA IN 1 – connector (0...33 mA)

The milliampere output (mA) I/O module is an add-on module with four (4) mA outputs and one (1) mA input. Both the outputs and the input are in two galvanically isolated groups, with one pin for the positive (+) connector and one pin for the negative (–) connector.

This module can be ordered directly to be installed into the device in the factory, or it can be upgraded in the field after the device's original installation when required.

The user sets the mA I/O with the mA outputs control function. This can be done at *Control* → *Device I/O* → *mA outputs* in the device configuration settings.

For further information please refer to the chapter titled "[Milliampere output module \(4 x mA out & 1 x mA in\)](#)" in the "Technical data" section of this manual.

The hardware configuration code of this module is "I". For more information, please refer to the "[Ordering information](#)" chapter of this document.

## 7.4.5 Milliampere input module (4x mA in & 1x mA out) (optional)

Figure. 7.4.5 - 111. Milliampere input (mA) I/O module connections. Can be equipped with standard screw terminals or spring cage terminals for connection.

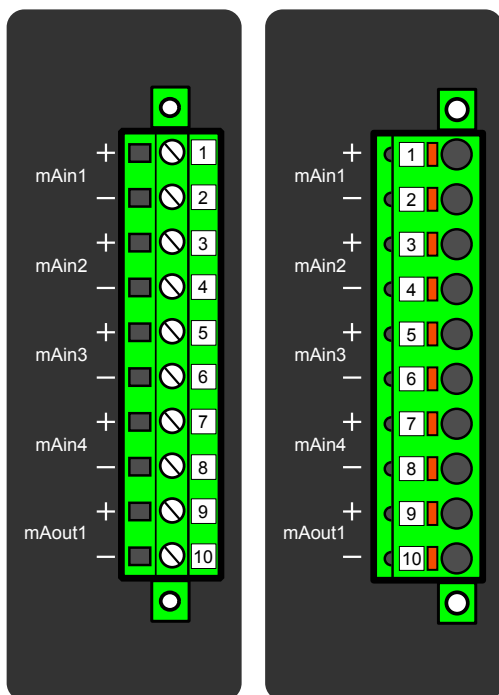

Connector	Description
Pin 1	mA IN 1 + connector (0...24 mA)
Pin 2	mA IN 1 – connector (0...24 mA)
Pin 3	mA IN 2 + connector (0...24 mA)
Pin 4	mA IN 2 – connector (0...24 mA)
Pin 5	mA IN 3 + connector (0...24 mA)
Pin 6	mA IN 3 – connector (0...24 mA)
Pin 7	mA IN 4 + connector (0...24 mA)
Pin 8	mA IN 4 – connector (0...24 mA)
Pin 9	mA OUT 1 + connector (0...33 mA)
Pin 10	mA OUT 1 – connector (0...33 mA)

The milliampere input (mA) I/O module is an add-on module with four (4) mA inputs and one (1) mA output. Both the inputs and the output are in two galvanically isolated groups, with one pin for the positive (+) connector and one pin for the negative (–) connector.

This module can be ordered directly to be installed into the device in the factory, or it can be upgraded in the field after the device's original installation when required.

The user sets the mA I/O with the mA output control function. This can be done at *Control* → *Device I/O* → *mA outputs* in the device configuration settings.

For further information please refer to the chapter titled "[Milliampere input module \(1x mA out & 4x mA in\)](#)" in the "Technical data" section of this manual.

The hardware configuration code of this module is "T". For more information, please refer to the "[Ordering information](#)" chapter of this document.

### 7.4.6 RTD input module (optional)

Figure. 7.4.6 - 112. RTD input module connectors.

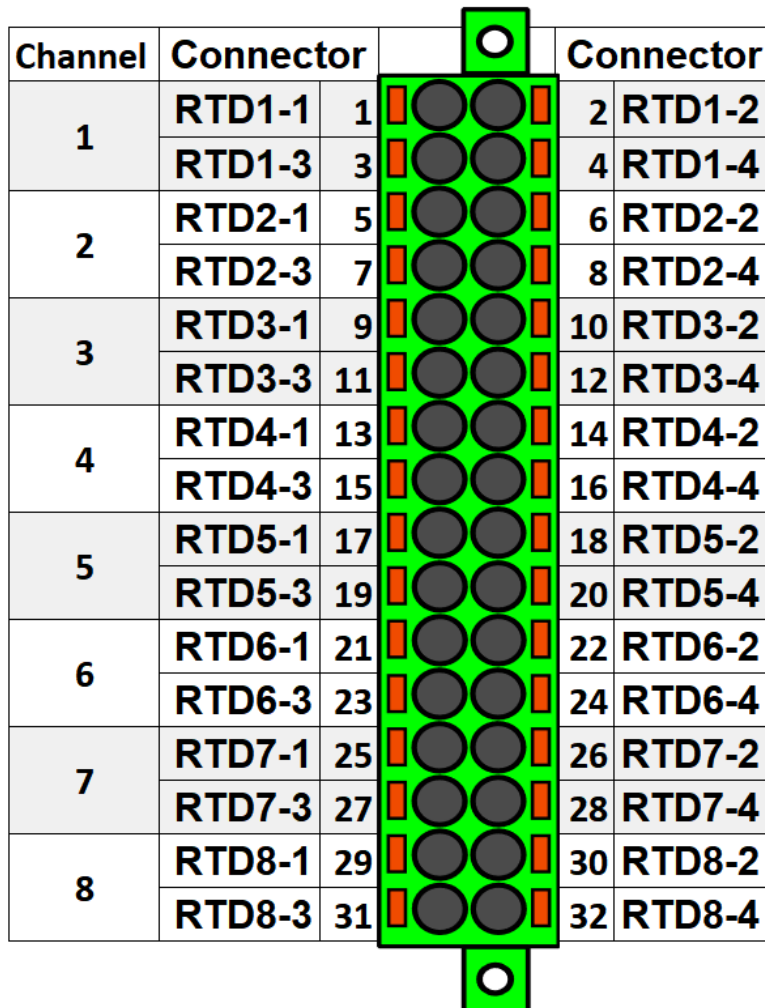

The RTD input module is an add-on module with eight (8) RTD input channels. Each input supports 2-wire, 3-wire and 4-wire RTD sensors. The sensor type can be selected with software for two groups, four channels each. The card supports Pt100 and Pt1000 sensors.

For further information please refer to the chapter titled "[RTD input module](#)" in the "Technical data" section of this manual.

The hardware configuration code of this module is "F". For more information, please refer to the "[Ordering information](#)" chapter of this document.

Figure. 7.4.6 - 113. RTD sensor connection types.

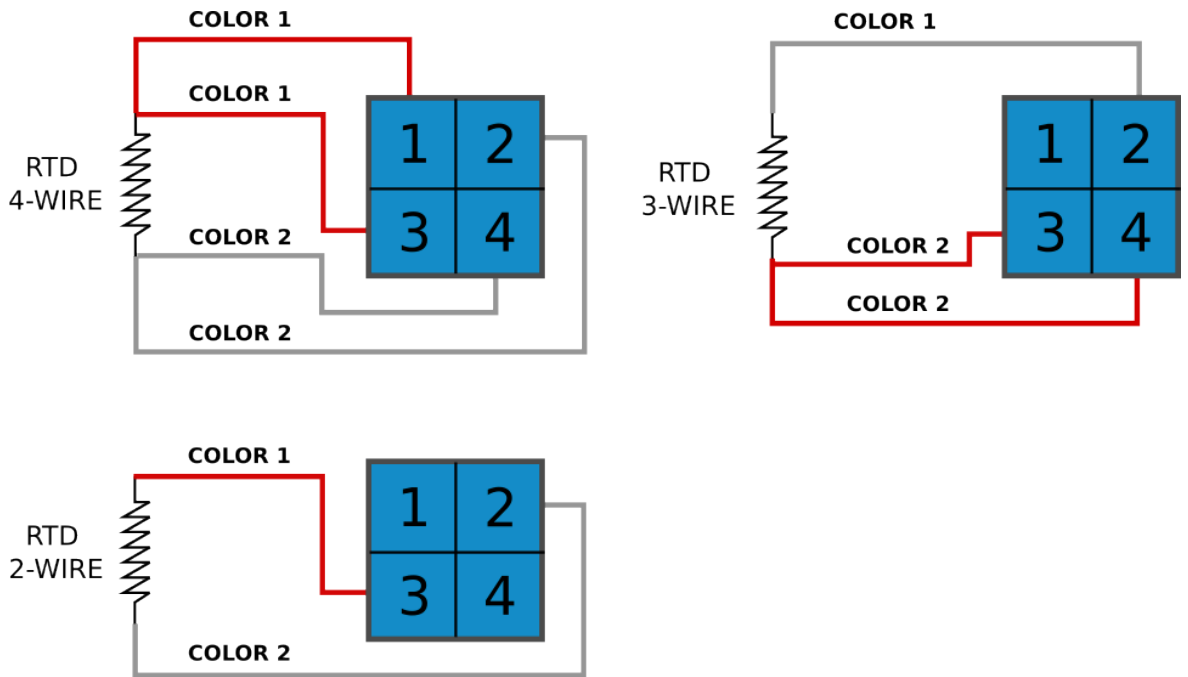

### 7.4.7 Double RJ45 Ethernet & IRIG-B communication module (optional)

Figure. 7.4.7 - 114. Double RJ-45 10/100 Mbps Ethernet communication module.

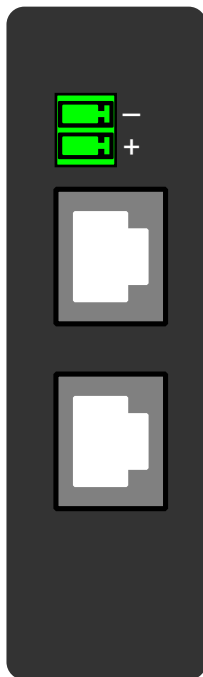

Connector	Description
Two-pin connector	<ul style="list-style-type: none"> <li>IRIG-B input</li> </ul>
RJ-45 connectors	<ul style="list-style-type: none"> <li>Two Ethernet ports</li> <li>RJ-45 connectors</li> <li>10BASE-T and 100BASE-TX</li> </ul>

This option card supports daisy chain configurations.

For further information please refer to the chapter titled "[Double RJ45 Ethernet & IRIG-B communication module](#)" in the "Technical data" section of this manual.

The hardware configuration code of this module is "G". For more information, please refer to the "[Ordering information](#)" chapter of this document.

## 7.4.8 Double SFP Ethernet & IRIG-B communication module (optional)

Figure. 7.4.8 - 115. Double SFP 100 Mbps Ethernet communication module.

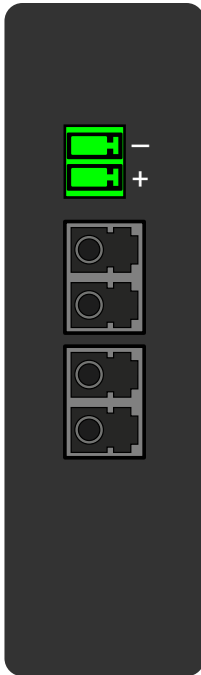

Connector	Description
Two-pin connector	<ul style="list-style-type: none"> <li>IRIG-B input</li> </ul>
SFP slots	<ul style="list-style-type: none"> <li>Two SFP slots</li> <li>Compatible SFP modules available as accessories</li> </ul>

For further information please refer to the chapter titled "[Double SFP Ethernet & IRIG-B communication module](#)" in the "Technical data" section of this manual.

The hardware configuration code of this module is "Q". For more information, please refer to the "[Ordering information](#)" chapter of this document.

## 7.4.9 Double ST 100 Ethernet & IRIG-B communication module (optional)

Figure. 7.4.9 - 116. Double ST 100 Mbps Ethernet communication module connectors.

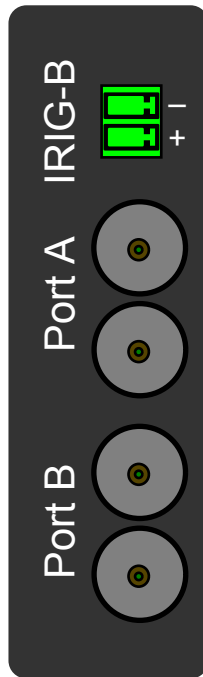

Connector	Description
Two-pin connector	<ul style="list-style-type: none"> <li>IRIG-B input</li> </ul>
ST connectors	<ul style="list-style-type: none"> <li>Duplex ST connectors</li> <li>62.5/125 <math>\mu\text{m}</math> or 50/125 <math>\mu\text{m}</math> multimode fiber</li> <li>Transmitter wavelength: 1260...1360 nm (nominal: 1310 nm)</li> <li>Receiver wavelength: 1100...1600 nm</li> <li>100BASE-FX</li> <li>Up to 2 km</li> </ul>

This option cards supports redundant ring configuration and multidrop configurations. Please note that each ring can only contain AQ 250 series devices, and any third party devices must be connected to a separate ring.

For further information please refer to the chapter titled "[Double ST Ethernet & IRIG-B communication module](#)" in the "Technical data" section of this manual.

The hardware configuration code of this module is "H". For more information, please refer to the "[Ordering information](#)" chapter of this document.

Figure. 7.4.9 - 117. Example of a multidrop configuration.

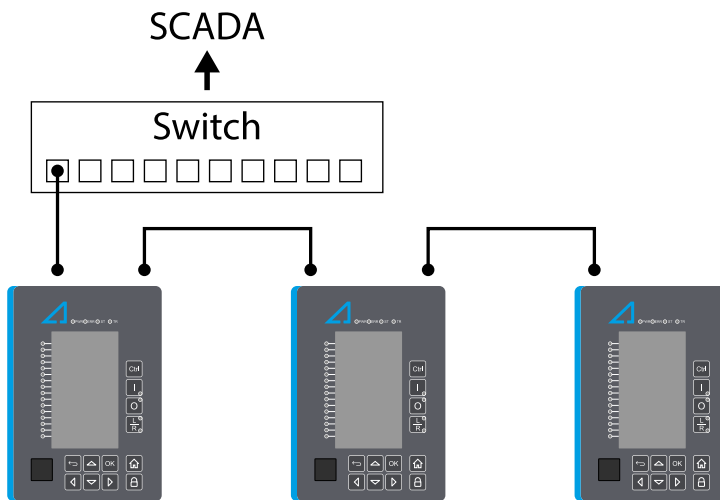

### 7.4.10 Double LC or RJ45 (HSR/PRP) Ethernet communication module (optional)

Figure. 7.4.10 - 118. LC and RJ45 100 Mbps Ethernet module connectors.

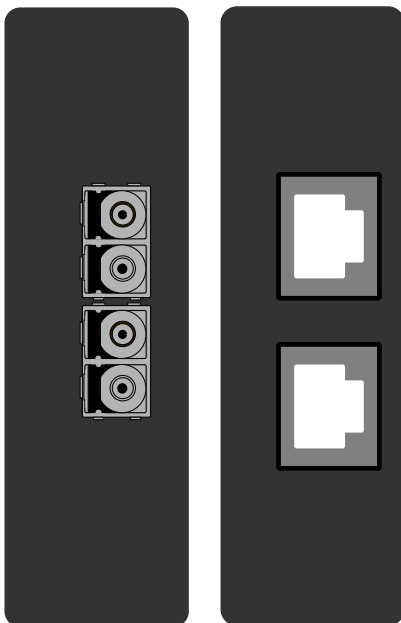

Card type	Description
LC ports	<ul style="list-style-type: none"> <li>• Communication port D, 100 Mbps LC fiber connector.</li> <li>• 62.5/125 μm or 50/125 μm multimode (glass).</li> <li>• Wavelength 1300 nm.</li> <li>• HSR and PRP protocols supported.</li> </ul>
RJ45	<ul style="list-style-type: none"> <li>• RJ-45 connectors.</li> <li>• 10BASE-T and 100BASE-TX.</li> <li>• HSR and PRP protocols supported.</li> </ul>

For further information please refer to the chapters titled "[Double LC \(HSR/PRP\) Ethernet communication module](#)" and "[Double RJ45 \(HSR/PRP\) Ethernet communication module](#)" in the "Technical data" section of this manual.

The hardware configuration codes of these modules are "J" (Double LC 100Mb Ethernet) and "K" (Double RJ45 100Mb Ethernet). For more information, please refer to the "[Ordering information](#)" chapter of this document.

### 7.4.11 Serial RS-232 communication module (optional)

Figure. 7.4.11 - 119. Serial RS-232 module connectors.

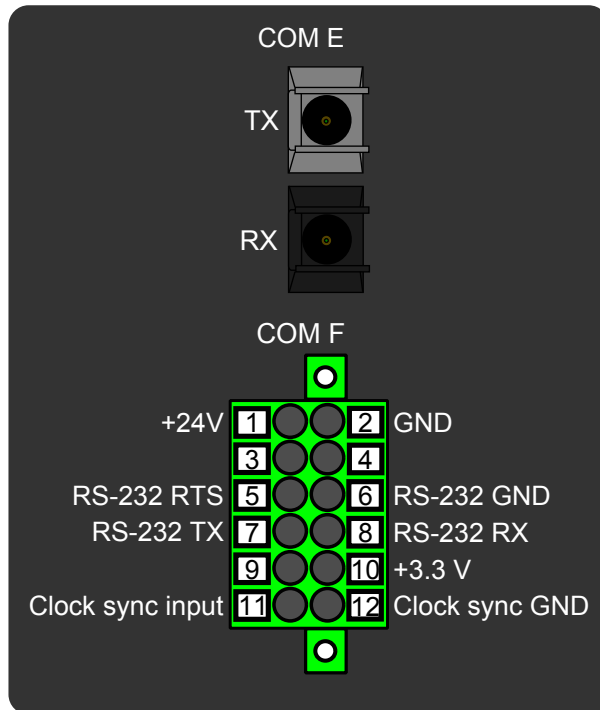

Table. 7.4.11 - 242. Module connections.

Connector	Pin	Name	Description
COM E	-	Serial fiber	<ul style="list-style-type: none"> <li>Serial-based communications</li> <li>Port options:                             <ul style="list-style-type: none"> <li>Glass/glass</li> <li>Plastic/plastic</li> <li>Glass/plastic</li> <li>Plastic/glass</li> </ul> </li> <li>Wavelength 660 nm</li> <li>Compatible with 50/125 <math>\mu\text{m}</math>, 62.5/125 <math>\mu\text{m}</math>, 100/140 <math>\mu\text{m}</math>, and 200 <math>\mu\text{m}</math> Plastic-Clad Silica (PCS) fiber</li> <li>Compatible with ST connectors</li> </ul>
COM F	1	+24 V input	Optional external auxiliary voltage for serial fiber.
	2	GND	
	3	-	Not in use.
	4	-	

Connector	Pin	Name	Description
	5	RS-232 RTS	Serial based communications.
	6	RS-232 GND	
	7	RS-232 TX	
	8	RS-232 RX	
	9	-	Not in use.
	10	+3.3 V output (spare)	Spare power source for external equipment (45 mA).
	11	Clock sync input	Clock synchronization input (supports IRIG-B).
	12	Clock sync GND	

The option card includes two serial communication interfaces: COM E is a serial fiber interface with glass/glass, plastic/plastic, glass/plastic and plastic/glass options, COM F is an RS-232 interface.

For further information please refer to the chapter titled "[RS-232 & serial fiber communication module](#)" in the "Technical data" section of this manual.

The hardware configuration codes of these modules are "L", "M", "N" and "O". For more information, please refer to the "[Ordering information](#)" chapter of this document.

## 7.5 Dimensions and installation

The device can be installed either to a standard 19" rack or to a switchgear panel with cutouts. The desired installation type is defined in the order code.

The figures below describe the device dimensions (first figure), the device installation (second), and the panel cutout dimensions and device spacing (third).

Figure. 7.5 - 120. Device dimensions.

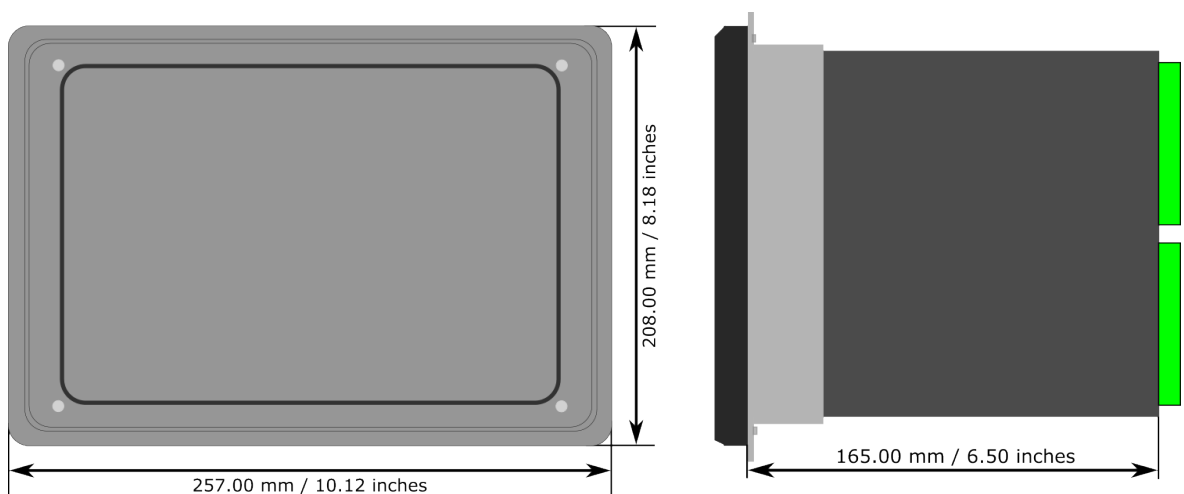

Figure. 7.5 - 121. Device installation.

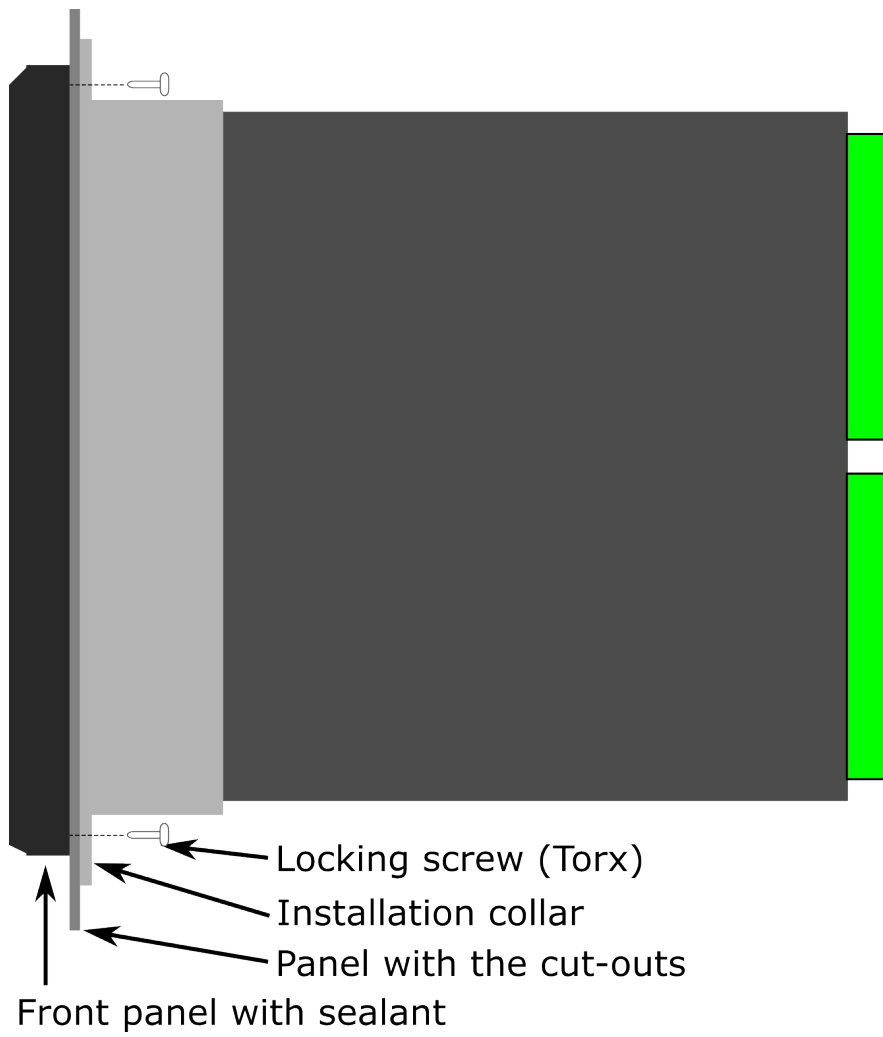
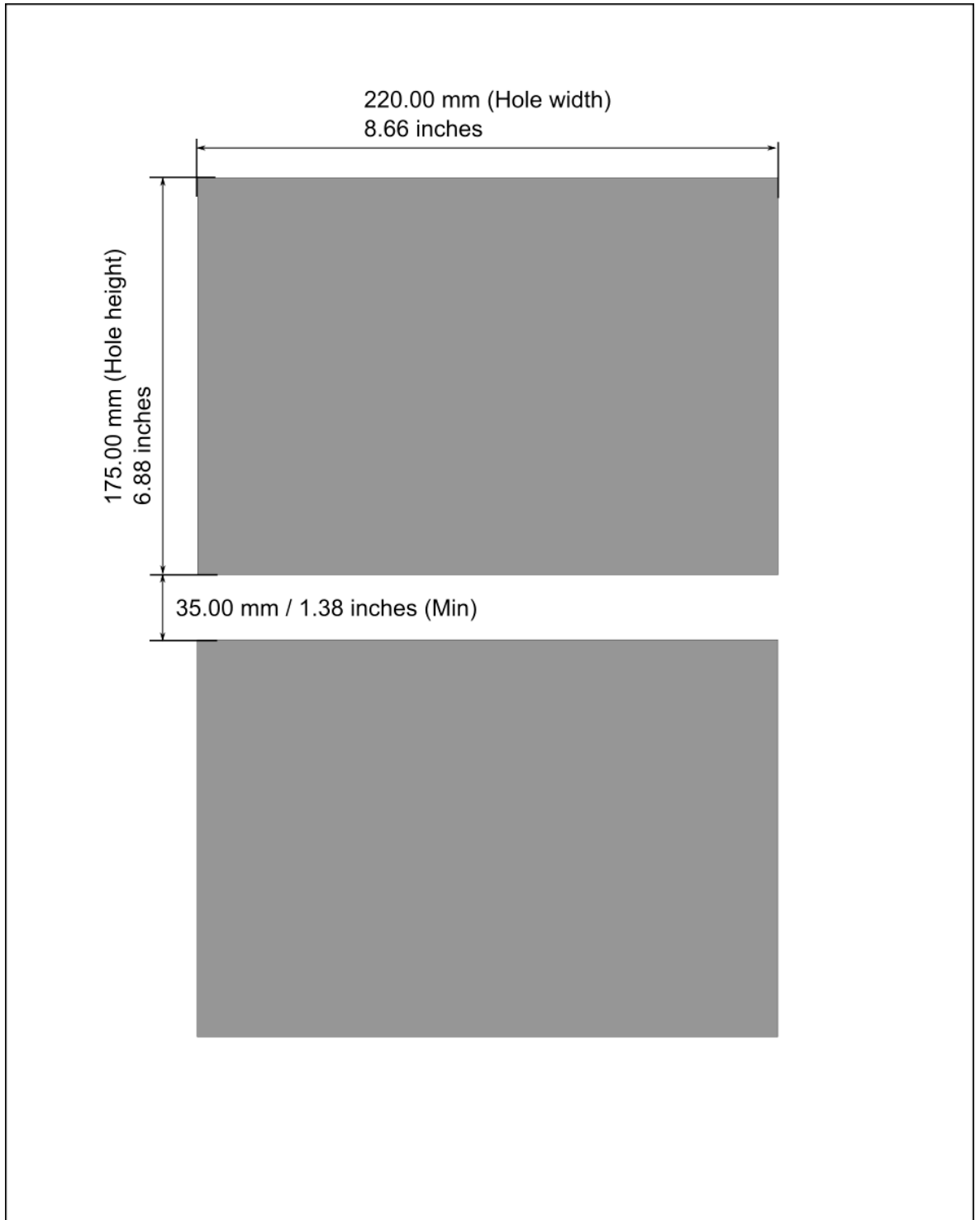

Figure. 7.5 - 122. Panel cut-out and spacing of the devices.



## 8 Technical data

### 8.1 Hardware

#### 8.1.1 Measurements

##### 8.1.1.1 Voltage measurement

Table. 8.1.1.1 - 243. Technical data for the voltage measurement module.

General information	
Spare part code	#SP-2XX-VT
Compatibility	AQ 210 series AQ 250 series AQ-ONE
Connection	
Measurement channels/VT inputs	4 independent VT inputs (U1, U2, U3 and U4)
Measurement	
Sample rate	64 samples per cycle in frequency range 6...75Hz
Voltage measuring range	0.50...480.00 V (RMS)
Rated voltage $U_N$	100 V / 110 V / 115 V / 120 V (RMS)
Voltage measurement inaccuracy	1...2 V $\pm 1.5\%$ 2...10 V $\pm 0.5\%$ 10...480 V $\pm 0.35\%$
Angle measurement inaccuracy	$\pm 0.2$ degrees (15...300 V) $\pm 1.5$ degrees (1...15 V)
Voltage measurement bandwidth (freq.)	7...75 Hz fundamental, up to the 31 <sup>st</sup> harmonic voltage
Terminal block connection	
Nominal cross section (solid or stranded wire)	6 mm <sup>2</sup>
Input impedance	$\sim 24.5 \text{ M}\Omega$
Burden (50/60 Hz)	<0.02 VA
Thermal withstand	630 V <sub>RMS</sub> (continuous)



**NOTICE!**

Voltage measurement accuracy has been verified with 50/60 Hz.

The amplitude difference is 0.2 % and the angle difference is 0.5 degrees higher at 16.67 Hz and other frequencies.

### 8.1.1.2 Voltage memory

Table. 8.1.1.2 - 244. Technical data for the voltage memory function.

Measurement inputs	
Voltage inputs	$U_{L1}, U_{L2}, U_{L3}$ $U_{L12}, U_{L23}, U_{L31} + U_0$
Current inputs (back-up frequency)	Phase current inputs: $I_{L1}$ (A), $I_{L2}$ (B), $I_{L3}$ (C)
Pick-up	
Pick-up voltage setting Pick-up current setting (optional)	2.00...50.00 % $U_N$ , setting step $0.01 \times \%U_N$ $0.01...50.00 \times I_N$ , setting step $0.01 \times I_N$
Inaccuracy: - Voltage - Current	$\pm 1.5 \%U_{SET}$ or $\pm 30$ mV $\pm 0.5 \%I_{SET}$ or $\pm 15$ mA ( $0.10...4.0 \times I_{SET}$ )
Operation time	
Angle memory activation delay	<20 ms (typically 5 ms)
Maximum active time	0.020...50.000 s, setting step 0.005 s
Inaccuracy: - Definite time ( $U_M/U_{SET}$ ratio >1.05)	$\pm 1.0 \%$ or $\pm 35$ ms
Angle memory	
Angle drift while voltage is absent	$\pm 1.0^\circ$ per 1 second
Reset	
Reset ratio: - Voltage memory (voltage) - Voltage memory (current)	103 % of the pick-up voltage setting 97 % of the pick-up current setting
Reset time	<50 ms

**NOTICE!**

Voltage memory is activated only when all line voltages fall below set pick-up value.

**NOTICE!**

Voltage memory activation captures healthy situation voltage angles, one cycle before actual activation (50Hz/20ms before "bolted" fault)

### 8.1.1.3 Frequency measurement

Table. 8.1.1.3 - 245. Frequency measurement accuracy.

Frequency measurement performance	
Frequency measuring range	6...75 Hz fundamental, up to the 31 <sup>st</sup> harmonic current or voltage

Inaccuracy	10 mHz
------------	--------

## 8.1.2 CPU & Power supply

Table. 8.1.2 - 246. General information for the CPU module.

General information	
Spare part code	#SP-250-CPU
Compatibility	AQ 210 series AQ 250 series AQ-ONE
Terminal block connection	
Solid or stranded wire Nominal cross section	2.5 mm <sup>2</sup>
RS-485 serial terminal block connection	
Maximum cross section (solid or stranded wire)	1.5 mm <sup>2</sup>

### 8.1.2.1 Auxiliary voltage

Table. 8.1.2.1 - 247. Power supply model A

Rated values	
Rated auxiliary voltage	80...265 V (AC/DC)
Power consumption	< 20 W (no option cards) < 40 W (maximum number of option cards)
Maximum permitted interrupt time	< 40 ms with 110 VDC
DC ripple	< 15 %
Other	
Minimum recommended fuse rating	MCB C2

Table. 8.1.2.1 - 248. Power supply model B

Rated values	
Rated auxiliary voltage	18...72 VDC
Power consumption	< 20 W (no option cards) < 40 W (maximum number of option cards)
Maximum permitted interrupt time	< 40 ms with 24 VDC
DC ripple	< 15 %

Other	
Minimum recommended fuse rating	MCB C2

### 8.1.2.2 CPU communication ports

Table. 8.1.2.2 - 249. Front panel local communication port.

Port	
Port media	Copper Ethernet RJ-45
Number of ports	1
Port protocols	PC-protocols FTP
Features	
Data transfer rate	100 MB/s
System integration	Can't be used for system protocols, only for local programming

Table. 8.1.2.2 - 250. Rear panel system communication port A.

Port	
Port media	Copper Ethernet RJ-45
Number of ports	1
Features	
Port protocols	IEC 61850 (1st edition) IEC61850 (2nd edition) IEC 104 Modbus/TCP DNP3 FTP
Data transfer rate	100 MB/s
System integration	Can be used for system protocols and for local programming

Table. 8.1.2.2 - 251. Rear panel system communication port B.

Port	
Port media	Copper RS-485
Number of ports	1
Features	

Port protocols	Modbus/RTU IEC 103 IEC 101 DNP3 SPA
Data transfer rate	65 580 kB/s
System integration	Can be used for system protocols

### 8.1.2.3 CPU digital inputs

Table. 8.1.2.3 - 252. CPU model-isolated digital inputs, with thresholds defined by order code.

Rated values	
Rated auxiliary voltage	265 V (AC/DC)
Nominal voltage	Order code defined: 24, 110, 220 V (AC/DC)
Pick-up threshold Release threshold	Order code defined: 19, 90, 170 V Order code defined: 14, 65, 132 V
Scanning rate	5 ms
Settings	
Pick-up delay	Software settable: 0...1800 s
Polarity	Software settable: Normally On/Normally Off
Current drain	2 mA

### 8.1.2.4 CPU digital outputs

Table. 8.1.2.4 - 253. Digital outputs (Normally Open)

Rated values	
Rated auxiliary voltage	265 V (AC/DC)
Continuous carry	5 A
Make and carry 0.5 s Make and carry 3 s	30 A 15 A
Breaking capacity, DC (L/R = 40 ms) at 48 VDC at 110 VDC at 220 VDC	1 A 0.4 A 0.2 A
Control rate	5 ms
Settings	
Polarity	Software settable: Normally Open / Normally Closed

Table. 8.1.2.4 - 254. Digital outputs (Change-Over)

Rated values	
Rated auxiliary voltage	265 V (AC/DC)
Continuous carry	2.5 A
Make and carry 0.5 s Make and carry 3 s	30 A 15 A
Breaking capacity, DC (L/R = 40 ms) at 48 VDC at 110 VDC at 220 VDC	1 A 0.3 A 0.15 A
Control rate	5 ms
Settings	
Polarity	Software settable: Normally Open / Normally Closed

**CAUTION!**

Please note, that signaling relay 5 and system fault's signaling relay are designed only for signaling purposes, and are not to be used in trip coil control.

## 8.1.3 Option cards

### 8.1.3.1 Digital input module

Table. 8.1.3.1 - 255. Technical data for the digital input module.

Spare part code	#SP-250-DI8
Compatibility	AQ 210 series models AQ 250 series models AQ-ONE
Rated values	
Rated auxiliary voltage	5...265 V (AC/DC)
Current drain	2 mA
Scanning rate Activation/release delay	5 ms 5...11 ms
Settings	
Pick-up threshold Release threshold	Software settable: 16...200 V, setting step 1 V Software settable: 10...200 V, setting step 1 V
Pick-up delay	Software settable: 0...1800 s
Drop-off delay	Software settable: 0...1800 s
Polarity	Software settable: Normally On/Normally Off

Terminal block connection	
Solid or stranded wire Nominal cross section	2.5 mm <sup>2</sup>

### 8.1.3.2 Digital output module

Table. 8.1.3.2 - 256. Technical data for the digital output module.

Spare part code	#SP-250-DO5
Compatibility	AQ 210 series models AQ 250 series models AQ-ONE
Rated values	
Rated auxiliary voltage	265 V (AC/DC)
Continuous carry	5 A
Make and carry 0.5 s Make and carry 3 s	30 A 15 A
Breaking capacity, DC (L/R = 40 ms) at 48 VDC at 110 VDC at 220 VDC	1 A 0.4 A 0.2 A
Control rate	5 ms
Settings	
Polarity	Software settable: Normally On/Normally Off
Terminal block connection	
Maximum cross section (solid or stranded wire)	2.5 mm <sup>2</sup>

### 8.1.3.3 High-speed and high-current output module

Table. 8.1.3.3 - 257. Technical data for the high-speed and high-current output module.

Spare part code	#SP-250-HSO
Compatibility	AQ 250 series models AQ-ONE
High-speed output rated values	
Rated auxiliary voltage	265 V (AC/DC)
Continuous carry	10 A
Make and carry 0.5 s Make and carry 3 s	30 A 15 A

Breaking capacity, DC (L/R = 40 ms) at 48 VDC at 110 VDC at 220 VDC	10 A
Control rate	1 ms
Operating time	Typically under 4 ms
<b>Trip Circuit Supervision input rated values</b>	
Rated auxiliary voltage	265 V (AC/DC)
Nominal voltage	Order code defined: 24, 110, 220 V (AC/DC)
Pick-up threshold	Order code defined: 19, 90, 170 V
Release threshold	Order code defined: 14, 65, 132 V
Scanning rate	5 ms
<b>High-speed output settings</b>	
Polarity	Software settable: Normally On/Normally Off
<b>Trip Circuit Supervision input settings</b>	
Release delay	Software settable: 0.000...1800.000 s
Polarity	Normally Closed
Current drain	2 mA
<b>Terminal block connection</b>	
Maximum cross section (solid or stranded wire)	2.5 mm <sup>2</sup>

### 8.1.3.4 Milliampere output module (4 x mA out & 1 x mA in)

Table. 8.1.3.4 - 258. Technical data for the milliampere output module.

Spare part code	#SP-2XX-MA
Compatibility	AQ 210 series models AQ 250 series models AQ-ONE
<b>Signals</b>	
Output magnitudes Input magnitudes	4 × mA output signal (DC) 1 × mA input signal (DC)
<b>mA input</b>	
Range (hardware) Range (measurement) Inaccuracy	0...33 mA 0...24 mA ±0.1 mA

Update cycle Response time at 5 ms cycle Update cycle time inaccuracy	5...10 000 ms, setting step 5 ms ~ 15 ms (13...18 ms) Max. +20 ms above the set cycle
mA input scaling range Output scaling range	0...4000 mA -1 000 000.0000...1 000 000.0000, setting step 0.0001
<b>mA output</b>	
Inaccuracy at 0...24 mA	±0.01 mA
Response time at 5 ms cycle [fixed]	< 5 ms
mA output scaling range Source signal scaling range	0...24 mA, setting step 0.001 mA -1 000 000.000...1 000 000.0000, setting step 0.0001
<b>Terminal block connection</b>	
Maximum cross section (solid or stranded wire)	2.5 mm <sup>2</sup>

### 8.1.3.5 Milliampere input module (1x mA out & 4x mA in)

Table. 8.1.3.5 - 259. Technical data for the milliampere input module.

Spare part code	#SP-250-MAIN
Compatibility	AQ 250 series models AQ-ONE
<b>Signals</b>	
Input magnitudes Output magnitudes	4 × mA input signal (DC) 1 × mA output signal (DC)
<b>mA input</b>	
Range (hardware) Range (measurement) Inaccuracy	0...33 mA 0...24 mA ±0.1 mA
Update cycle Response time at 5 ms cycle Update cycle time inaccuracy	5...10 000 ms, setting step 5 ms ~ 15 ms (13...18 ms) Max. +20 ms above the set cycle
mA input scaling range Output scaling range	0...4000 mA -1 000 000.0000...1 000 000.0000, setting step 0.0001
<b>mA output</b>	
Inaccuracy at 0...24 mA	±0.01 mA
Response time at 5 ms cycle [fixed]	< 5 ms
mA output scaling range Source signal scaling range	0...24 mA, setting step 0.001 mA -1 000 000.000...1 000 000.0000, setting step 0.0001
<b>Terminal block connection</b>	

Maximum cross section (solid or stranded wire)	2.5 mm <sup>2</sup>
--	---------------------

### 8.1.3.6 RTD input module

Table. 8.1.3.6 - 260. Technical data for the RTD input module.

Spare part code	#SP-2xx-RTD
Compatibility	AQ 210 series models AQ 250 series models AQ-ONE
<b>Channels 1-8</b>	
2/3/4-wire RTD	
Pt100 or Pt1000	
<b>Terminal block connection</b>	
Maximum cross section (solid or stranded wire)	1.5 mm <sup>2</sup>

### 8.1.3.7 Double RJ-45 Ethernet & IRIG-B communication module

Table. 8.1.3.7 - 261. Technical data for the double RJ-45 Ethernet communication module.

Spare part code	#SP-2XX-ETH-RJ45
Compatibility	AQ 210 series models AQ 250 series models AQ-ONE
<b>Ethernet connector features</b>	
Protocols	IEC 61850 IEC 104 Modbus/TCP DNP3 FTP
Data transfer rate	100 MB/s
System integration	Can be used for system protocols and for local programming
Number of ports	2
Communication ports	Copper Ethernet RJ-45
<b>IRIG-B Connector</b>	
Maximum cross section (solid or stranded wire)	1.5 mm <sup>2</sup>

### 8.1.3.8 Double SFP Ethernet & IRIG-B communication module

Table. 8.1.3.8 - 262. Technical data for the double SFP Ethernet communication module.

Spare part code	#SP-250-ETH-SFP
Compatibility	AQ 250 series models AQ-ONE
<b>Ethernet connector features</b>	
Protocols	IEC 61850 IEC 104 Modbus/TCP DNP3 FTP
Data transfer rate	100 MB/s
System integration	Can be used for system protocols and for local programming
Number of ports	2
Communication ports	SFP
<b>IRIG-B Connector</b>	
Maximum cross section (solid or stranded wire)	1.5 mm <sup>2</sup>

### 8.1.3.9 Double ST Ethernet & IRIG-B communication module

Table. 8.1.3.9 - 263. Technical data for the double ST 100 Mbps Ethernet communication module.

Spare part code	#SP-2XX-2XST
Compatibility	AQ 210 series models AQ 250 series models AQ-ONE
<b>Protocols</b>	
Protocols	IEC61850 DNP/TCP Modbus/TCP IEC104 FTP
<b>ST connectors</b>	
Connector type	Duplex ST connectors 62.5/125 µm or 50/125 µm multimode fiber 100BASE-FX
Number of connectors	2
Transmitter wavelength	1260...1360 nm (nominal: 1310 nm)

Receiver wavelength	1100...1600 nm
Maximum distance	2 km
Data transfer rate	100 MB/s
<b>IRIG-B Connector</b>	
Maximum cross section (solid or stranded wire)	1.5 mm <sup>2</sup>

### 8.1.3.10 Double LC (HSR/PRP) Ethernet communication module

Table. 8.1.3.10 - 264. Technical data for the double LC 100 Mbps Ethernet communication module.

Spare part code	#SP-2XX-2LC(HSR/PRP)
Compatibility	AQ 210 series models AQ 250 series models AQ-ONE
<b>Protocols</b>	
Protocols	IEC 61850 IEC 104 Modbus/TCP DNP3 FTP
Redundancy	HSR and PRP
Data transfer rate	100 MB/s
System integration	Can be used for system protocols and for local programming
<b>Ports</b>	
Number of fiber ports	2
Communication port	LC fiber connector Wavelength 1300 nm
Fiber cable	50/125 µm or 62.5/125 µm multimode (glass)

### 8.1.3.11 Double RJ-45 (HSR/PRP) Ethernet communication module

Table. 8.1.3.11 - 265. Technical data for the double RJ-45 100 Mbps Ethernet communication module.

Spare part code	#SP-2XX-2RJ45(HSR/PRP)
Compatibility	AQ 210 series models AQ 250 series models AQ-ONE
<b>Features</b>	

Protocols	IEC 61850 IEC 104 Modbus/TCP DNP3 FTP
Redundancy	HSR and PRP
Data transfer rate	100 MB/s
System integration	Can be used for system protocols and for local programming
<b>Ports</b>	
Number of ports	2
Communication port	Copper Ethernet RJ-45

### 8.1.3.12 RS-232 & serial fiber communication module

Table. 8.1.3.12 - 266. Technical data for the RS-232 & serial fiber communication module.

PP Spare part code	#SP-2XX-232PP
PG Spare part code	#SP-2XX-232PG
GP Spare part code	#SP-2XX-232GP
GG Spare part code	#SP-2XX-232GG
Compatibility	AQ 210 series models AQ 250 series models AQ-ONE
<b>Serial fiber connections</b>	
Connection types	<ul style="list-style-type: none"> <li>• Plastic - Plastic</li> <li>• Plastic - Glass</li> <li>• Glass - Plastic</li> <li>• Glass - Glass</li> </ul>
Wavelength (plastic)	660 nm
Wavelength (glass)	820 nm
Cable type	1 mm plastic fiber
<b>RS-232 terminal block connections</b>	
Maximum cross section (solid or stranded wire)	1.5 mm <sup>2</sup>

### 8.1.4 Display

Table. 8.1.4 - 267. Technical data for the HMI TFT display.

<b>General information</b>
----------------------------

Spare part code	#SP-200-DISP
Compatibility	AQ-250 series models
<b>Dimensions and resolution</b>	
Number of dots/resolution	800 x 480
Size	154.08 × 85.92 mm (6.06 × 3.38 in)
<b>Display</b>	
Type of display	TFT
Color	RGB color

## 8.2 Functions

### 8.2.1 Protection functions

#### 8.2.1.1 Circuit breaker failure protection (CBFP; 50BF/52BF)

Table. 8.2.1.1 - 268. Technical data for the circuit breaker failure protection function.

<b>Measurement inputs</b>	
Current inputs	Phase current inputs: $I_{L1}$ (A), $I_{L2}$ (B), $I_{L3}$ (C) Residual current channel $I_{01}$ (Coarse) Residual current channel $I_{02}$ (Fine)
Current input magnitudes	RMS phase currents RMS residual current ( $I_{01}$ , $I_{02}$ or calculated $I_0$ )
<b>Pick-up</b>	
Monitored signals	Digital input status, digital output status, logical signals
Pick-up current setting: - $I_{L1}...I_{L3}$ - $I_{01}$ , $I_{02}$ , $I_{0Calc}$	$0.10...40.00 \times I_N$ , setting step $0.01 \times I_N$ $0.005...40.00 \times I_N$ , setting step $0.005 \times I_N$
Inaccuracy: - Starting phase current (5A) - Starting $I_{01}$ (1 A) - Starting $I_{02}$ (0.2 A) - Starting $I_{0Calc}$ (5 A)	$\pm 0.5 \% I_{SET}$ or $\pm 15$ mA ( $0.10...4.0 \times I_{SET}$ ) $\pm 0.5 \% I_{0SET}$ or $\pm 3$ mA ( $0.005...10.0 \times I_{SET}$ ) $\pm 1.5 \% I_{0SET}$ or $\pm 1.0$ mA ( $0.005...25.0 \times I_{SET}$ ) $\pm 1.0 \% I_{0SET}$ or $\pm 15$ mA ( $0.005...4.0 \times I_{SET}$ )
<b>Operation time</b>	
Definite time function operating time setting	$0.050...1800.000$ s, setting step $0.005$ s
Inaccuracy: - Current criteria ( $I_M/I_{SET}$ ratio $1.05 \rightarrow$ ) - DO or DI only	$\pm 1.0 \%$ or $\pm 55$ ms $\pm 15$ ms
<b>Reset</b>	
Reset ratio	97 % of the pick-up current setting

Reset time	<50 ms
------------	--------

## 8.2.1.2 Overvoltage protection ( $U>$ ; 59)

Table. 8.2.1.2 - 269. Technical data for the overvoltage function.

Measurement inputs	
Voltage inputs	$U_{L1}, U_{L2}, U_{L3}$ $U_{L12}, U_{L23}, U_{L31} (+ U_0)$
Voltage input magnitudes	RMS line-to-line or line-to-neutral voltages
Pick-up	
Pick-up terms	1 voltage 2 voltages 3 voltages
Pick-up setting	1.00...250.00 % $U_N$ , setting step 0.01 % $U_N$
Inaccuracy: - Voltage	$\pm 1.5$ % $U_{SET}$
Operating time	
Definite time function operating time setting	0.000...1800.000 s, setting step 0.005 s
Inaccuracy: - Definite time ( $U_M/U_{SET}$ ratio 1.05→)	$\pm 1.0$ % or $\pm 35$ ms
IDMT setting parameters: - k Time dial setting for IDMT - IDMT Multiplier	0.01...60.00, step 0.01 0...25.00, step 0.01
Inaccuracy: - IDMT operating time - IDMT minimum operating time	$\pm 1.5$ % or $\pm 20$ ms $\pm 20$ ms
Instant operation time	
Start time and instant operation time (trip): - $U_M/U_{SET}$ ratio 1.05→	<50 ms
Reset	
Reset ratio	97 % of the pick-up voltage setting
Reset time setting Inaccuracy: Reset time	0.000...150.000 s, step 0.005 s $\pm 1.0$ % or $\pm 45$ ms
Instant reset time and start-up reset	<50 ms

### 8.2.1.3 Undervoltage protection ( $U_{<}$ ; 27)

Table. 8.2.1.3 - 270. Technical data for the undervoltage function.

Measurement inputs	
Voltage inputs	$U_{L1}, U_{L2}, U_{L3}$ $U_{L12}, U_{L23}, U_{L31} (+ U_0)$
Voltage input magnitudes	RMS line-to-line or line-to-neutral voltages
Pick-up	
Pick-up terms	1 voltage 2 voltages 3 voltages
Pick-up setting	0.00...120.00 % $U_N$ , setting step 0.01 % $U_N$
Inaccuracy: - Voltage	$\pm 1.5$ % $U_{SET}$ or $\pm 30$ mV
Low voltage block	
Pick-up setting	0.00...80.00 % $U_N$ , setting step 0.01 % $U_N$
Inaccuracy: - Voltage	$\pm 1.5$ % $U_{SET}$ or $\pm 30$ mV
Operation time	
Definite time function operating time setting	0.000...1800.000 s, setting step 0.005 s
Inaccuracy: - Definite time ( $U_M/U_{SET}$ ratio 1.05 $\rightarrow$ )	$\pm 1.0$ % or $\pm 35$ ms
IDMT setting parameters: - k Time dial setting for IDMT - IDMT Multiplier	0.01...60.00, step 0.01 0...25.00, step 0.01
Inaccuracy: - IDMT operating time - IDMT minimum operating time	$\pm 1.5$ % or $\pm 20$ ms $\pm 20$ ms
Instant operation time	
Start time and instant operation time (trip): - $U_M/U_{SET}$ ratio 1.05 $\rightarrow$	<65 ms
Retardation time (overshoot)	<30 ms
Reset	
Reset ratio	103 % of the pick-up voltage setting
Reset time setting Inaccuracy: Reset time	0.000...150.000 s, step 0.005 s $\pm 1.0$ % or $\pm 45$ ms
Instant reset time and start-up reset	<50 ms



**NOTICE!**

The low-voltage block is not in use when its pick-up setting is set to 0 %. The undervoltage function trip signal is active when the LV block is disabled, and the device has no voltage injection.



**NOTICE!**

After the low voltage blocking condition, the undervoltage stage does not trip unless the voltage exceeds the pick-up setting first.

## 8.2.1.4 Neutral overvoltage protection (U<sub>0</sub>>; 59N)

Table. 8.2.1.4 - 271. Technical data for the neutral overvoltage function.

Measurement inputs	
Voltage input (selectable)	Residual voltage from U3 or U4 voltage channel Residual voltage calculated from U <sub>L1</sub> , U <sub>L2</sub> , U <sub>L3</sub>
Voltage input magnitudes	RMS residual voltage U <sub>0</sub> Calculated RMS residual voltage U <sub>0</sub>
Pick-up	
Pick-up voltage setting	1.00...50.00 % U <sub>0N</sub> , setting step 0.01 × I <sub>N</sub>
Inaccuracy: - Voltage U <sub>0</sub> - Voltage U <sub>0Calc</sub>	±1.5 %U <sub>0SET</sub> or ±30 mV ±150 mV
Operation time	
Definite time function operating time setting	0.000...1800.000 s, setting step 0.005 s
Inaccuracy: - Definite time (U <sub>0M</sub> /U <sub>0SET</sub> ratio 1.05→)	±1.0 % or ±45 ms
IDMT setting parameters: - k Time dial setting for IDMT - IDMT Multiplier	0.01...60.00, step 0.01 0...25.00, step 0.01
Inaccuracy: - IDMT operating time - IDMT minimum operating time	±1.5 % or ±20 ms ±20 ms
Instant operation time	
Start time and instant operation time (trip): - U <sub>0M</sub> /U <sub>0SET</sub> ratio 1.05→	<50 ms
Reset	
Reset ratio	97 % of the pick-up voltage setting
Reset time setting Inaccuracy: Reset time	0.000 ... 150.000 s, step 0.005 s ±1.0 % or ±50 ms
Instant reset time and start-up reset	<50 ms

## 8.2.1.5 Sequence voltage protection ( $U_1/U_2 > / <$ ; 47/27P/59NP)

Table. 8.2.1.5 - 272. Technical data for the sequence voltage function.

Measurement inputs	
Voltage inputs	$U_{L1}, U_{L2}, U_{L3}$ $U_{L12}, U_{L23}, U_{L31} (+ U_0)$
Voltage input calculations	Positive sequence voltage (I1) Negative sequence voltage (I2)
Pick-up	
Pick-up setting	5.00...150.00 % $U_N$ , setting step 0.01 % $U_N$
Inaccuracy: - Voltage	$\pm 1.5$ % $U_{SET}$ or $\pm 30$ mV
Low voltage block	
Pick-up setting	1.00...80.00 % $U_N$ , setting step 0.01 % $U_N$
Inaccuracy: -Voltage	$\pm 1.5$ % $U_{SET}$ or $\pm 30$ mV
Operation time	
Definite time function operating time setting	0.000...1800.000 s, setting step 0.005 s
Inaccuracy -Definite Time ( $U_M/U_{SET}$ ratio 1.05 $\rightarrow$ )	$\pm 1.0$ % or $\pm 35$ ms
IDMT setting parameters: - k Time dial setting for IDMT - IDMT Multiplier	0.01...60.00, step 0.01 0...25.00, step 0.01
Inaccuracy: - IDMT operating time - IDMT minimum operating time	$\pm 1.5$ % or $\pm 20$ ms $\pm 20$ ms
Instant operation time	
Start time and instant operation time (trip): - $U_M/U_{SET}$ ratio $<0.95/1.05\rightarrow$	$<65$ ms
Reset	
Reset ratio	97 or 103 % of the pick-up voltage setting
Reset time setting Inaccuracy: Reset time	0.000...150.000 s, step 0.005 s $\pm 1.0$ % or $\pm 35$ ms
Instant reset time and start-up reset	$<50$ ms

## 8.2.1.6 Overfrequency and underfrequency protection ( $f > / <$ ; 81O/81U)

Table. 8.2.1.6 - 273. Technical data for the overfrequency and underfrequency function.

Input signals	
Sampling mode	Fixed Tracking
Frequency reference 1 Frequency reference 2 Frequency reference 3	CT1IL1, CT2IL1, VT1U1, VT2U1 CT1IL2, CT2IL2, VT1U2, VT2U2 CT1IL3, CT2IL3, VT1U3, VT2U3
Pick-up	
$f >$ pick-up setting $f <$ pick-up setting	10.00...70.00 Hz, setting step 0.01 Hz 7.00...65.00 Hz, setting step 0.01 Hz
Inaccuracy (sampling mode): - Fixed - Tracking	$\pm 20$ mHz (50/60 Hz fixed frequency) $\pm 20$ mHz ( $U > 30$ V secondary) $\pm 20$ mHz ( $I > 30$ % of rated secondary)
Operation time	
Definite time function operating time setting	0.000...1800.000 s, setting step 0.005 s
Inaccuracy: - Definite time ( $I_M/I_{SET}$ ratio $\pm 50$ mHz)	$\pm 1.5$ % or $\pm 50$ ms (max. step size: 100 mHz)
Instant operation time	
Start time and instant operation time (trip): - $I_M/I_{SET}$ ratio $\pm 50$ mHz (Fixed) - $I_M/I_{SET}$ ratio $\pm 50$ mHz (Tracking)	$< 70$ ms (max. step size: 100 mHz) $< 3$ cycles or $< 60$ ms (max. step size: 100 mHz)
Reset	
Reset ratio	0.020 Hz
Instant reset time and start-up reset: - $I_M/I_{SET}$ ratio $\pm 50$ mHz (Fixed) - $I_M/I_{SET}$ ratio $\pm 50$ mHz (Tracking)	$< 110$ ms (max. step size: 100 mHz) $< 3$ cycles or $< 70$ ms (max. step size: 100 mHz)



**NOTICE!**

Measuring frequency requires that the secondary voltage exceeds 2 volts, or the current exceeds 0.25 amperes (peak-to-peak).



**NOTICE!**

The frequency is measured two seconds after a signal is received.

## 8.2.1.7 Resistance temperature detectors (RTD)

Table. 8.2.1.7 - 274. Technical data of the resistance temperature detectors.

Inputs
--------

Resistance input magnitudes	Measured temperatures measured by RTD sensors
RTD channels	12 individual RTD channels
Settable alarms	24 alarms available (two per each RTD channel)
<b>Pick-up</b>	
Alarm setting range Inaccuracy Reset ratio	101.00...2000.00 deg, setting step 0.1 deg (either < or > setting) ±3 % of the set pick-up value 97 % of the pick-up setting
<b>Operation</b>	
Operating time	Typically <500 ms

## 8.2.2 Control functions

### 8.2.2.1 Setting group selection

Table. 8.2.2.1 - 275. Technical data for the setting group selection function.

<b>Settings and control modes</b>	
Setting groups	8 independent, control-prioritized setting groups
Control scale	Common for all installed functions which support setting groups
<b>Control mode</b>	
Local	Any binary signal available in the device
Remote	Force change overrule of local controls either from the setting tool, HMI or SCADA
<b>Operation time</b>	
Reaction time	<5 ms from receiving the control signal

### 8.2.2.2 Object control and monitoring

Table. 8.2.2.2 - 276. Technical data for the object control and monitoring function.

<b>General</b>	
Number of objects	10
Supported object types	Circuit breaker Circuit breaker with withdrawable cart Disconnecter (MC) Disconnecter (GND) Custom object image
<b>Signals</b>	
Input signals	Digital inputs Software signals

Output signals	Close command output Open command output
<b>Operation time</b>	
Breaker traverse time setting	0.02...500.00 s, setting step 0.02 s
Max. close/open command pulse length	0.02...500.00 s, setting step 0.02 s
Control termination time out setting	0.02...500.00 s, setting step 0.02 s
Inaccuracy: - Definite time operating time	±0.5 % or ±10 ms
<b>Breaker control operation time</b>	
External object control time	<75 ms
Object control during auto-reclosing	See the technical sheet for the auto-reclosing function.

Table. 8.2.2.2 - 277. Technical data for the circuit breaker wear monitoring function.

<b>Pick-up</b>	
Breaker characteristics settings: - Nominal breaking current - Maximum breaking current - Operations with nominal current - Operations with maximum breaking current	0.00...100.00 kA, setting step 0.001 kA 0.00...100.00 kA, setting step 0.001 kA 0...200 000 operations, setting step 1 operation 0...200 000 operations, setting step 1 operation
Pick-up setting for Alarm 1 and Alarm 2	0...200 000 operations, setting step 1 operation
<b>Inaccuracy</b>	
Inaccuracy for current/operations counter: - Current measurement element - Operation counter	$0.1 \times I_N > I < 2 \times I_N$ ±0.2 % of the measured current, rest 0.5 % ±0.5 % of operations deducted

### 8.2.2.3 Indicator object monitoring

Table. 8.2.2.3 - 278. Technical data for the indicator object monitoring function.

<b>General</b>	
Number of objects	10
Supported object types	Disconnecter (GND) Custom object image
<b>Signals</b>	
Input signals	Digital inputs Software signals

### 8.2.2.4 Switch-on-to-fault (SOTF)

Table. 8.2.2.4 - 279. Technical data for the switch-on-to-fault function.

Initialization signals	
SOTF activate input	Any blocking input signal (Object closed signal, etc.)
Pick-up	
SOTF function input	Any blocking input signal (> or similar)
SOTF activation time	
Activation time	<40 ms (measured from the trip contact)
SOTF release time	
Release time setting	0.000...1800.000 s, setting step 0.005 s
Inaccuracy: - Definite time	±1.0 % or ±30 ms
SOTF instant release time	<40 ms (measured from the trip contact)

### 8.2.2.5 Vector jump ( $\Delta\phi$ ; 78)

Table. 8.2.2.5 - 280. Technical data for the vector jump protection function.

Measurement inputs	
Voltage inputs	$U_{L1}, U_{L2}, U_{L3}$ $U_{L12}, U_{L23}, U_{L31} + U_0$
Monitored voltages	Any or all system line-to-line voltage(s) Any or all system line-to-neutral voltage(s) Specifically chosen line-to-line or line-to-neutral voltage U4 channel voltage
Pick-up	
Pick-up setting	0.05...30.00°, setting step 0.01°
Inaccuracy: - Voltage angle	±30% overreach or 1.00 °
Low-voltage blocking	
Pick-up setting	0.01...100.00 % $U_N$ , setting step 0.01 % $U_N$
Inaccuracy: - Voltage	±1.5 % $U_{SET}$ or ±30 mV
Instant operation time	
Alarm and trip operation time: - ( $I_m/I_{set}$ ratio > ±30% overreach or 1.00 °)	<40 ms (typically 30 ms) 50/60 Hz <50 ms (typically 40 ms) 16.67 Hz

Reset	
Trip pulse	~5-10ms

### 8.2.2.6 Synchrocheck ( $\Delta V/\Delta a/\Delta f$ ; 25)

Table. 8.2.2.6 - 281. Technical data for the synchrocheck function.

Input signals	
Voltage inputs	U1, U2, U3 or U4 voltage channel
Voltage input magnitudes	RMS line-to-line or line-to-neutral voltages U3 or U4 voltage channel RMS
Pick-up	
U diff < setting	2.00...50.00 %U <sub>N</sub> , setting step 0.01 %U <sub>N</sub>
Angle diff < setting	3.0...90.0 deg, setting step 0.10 deg
Freq diff < setting	0.05...0.50 Hz, setting step 0.01 Hz
Inaccuracy: - Voltage - Frequency - Angle	±3.0 %U <sub>SET</sub> or ±0.3 %U <sub>N</sub> ±25 mHz (U > 30 V secondary) ±1.5° (U > 30 V secondary)
Reset	
Reset ratio: - Voltage - Frequency - Angle	99 % of the pick-up voltage setting 20 mHz ±2.0°
Activation time	
Activation (to LD/DL/DD) Activation (to Live Live)	<35 ms <60 ms
Reset	<40 ms
Bypass modes	
Voltage check mode (excluding LL)	LL+LD, LL+DL, LL+DD, LL+LD+DL, LL+LD+DD, LL+DL+DD, bypass
U live > limit U dead < limit	0.10...100.00 %U <sub>N</sub> , setting step 0.01 %U <sub>N</sub> 0.00...100.00 %U <sub>N</sub> , setting step 0.01 %U <sub>N</sub>



**NOTICE!**

The minimum voltage for direction and frequency solving is 20.0 %U<sub>N</sub>.

## 8.2.3 Monitoring functions

### 8.2.3.1 Voltage transformer supervision (60)

Table. 8.2.3.1 - 282. Technical data for the voltage transformer supervision function.

Measurement inputs	
Voltage inputs	$U_{L1}, U_{L2}, U_{L3}$ $U_{L12}, U_{L23}, U_{L31}$
Voltage input magnitudes	RMS line-to-line or line-to-neutral voltages
Pick-up	
Pick-up settings: - Voltage (low pick-up) - Voltage (high pick-up) - Angle shift limit	0.05...0.50 × $U_N$ , setting step 0.01 × $U_N$ 0.50...1.10 × $U_N$ , setting step 0.01 × $U_N$ 2.00...90.00 deg, setting step 0.10 deg
Inaccuracy: - Voltage - U angle ( $U > 1$ V)	±1.5 % $U_{SET}$ ±1.5°
External line/bus side pick-up (optional)	0 → 1
Time delay for alarm	
Definite time function operating time setting	0.000...1800.000 s, setting step 0.005 s
Inaccuracy: - Definite time ( $U_M/U_{SET}$ ratio > 1.05/0.95)	±1.0 % or ±35 ms
Instant operation time (alarm): - $U_M/U_{SET}$ ratio > 1.05/0.95	<80 ms
VTS MCB trip bus/line (external input)	<50 ms
Reset	
Reset ratio	97/103 % of the pick-up voltage setting
Reset time setting Inaccuracy: Reset time	0.000...150.000 s, step 0.005 s ±2.0 % or ±80 ms
Instant reset time and start-up reset	<50 ms
VTS MCB trip bus/line (external input)	<50 ms



#### NOTICE!

When turning on the auxiliary power of a device, the normal condition of a stage has to be fulfilled before tripping.

## 8.2.3.2 Event logger

Table. 8.2.3.2 - 283. Technical data for the event logger function.

General information	
Event history capacity	15 000 events
Event timestamp resolution	1 ms

## 8.2.3.3 Disturbance recorder

Table. 8.2.3.3 - 284. Technical data for the disturbance recorder function.

Recorded values	
Recorder analog channels	0...20 channels Freely selectable
Recorder digital channels	0...96 channels Freely selectable analog and binary signals 1 ms or 5 ms sample rate (FFT)
Performance	
Sample rate	8, 16, 32 or 64 samples/cycle
Recording length	0.000...1800.000 s, setting step 0.001 s The maximum length is determined by the chosen signals.
Number of recordings	0...100, 60 MB of shared flash memory reserved The maximum number of recordings according to the chosen signals and operation time setting combined

## 8.3 Tests and environmental

### Electrical environment compatibility

Table. 8.3 - 285. Disturbance tests.

All tests	CE-approved and tested according to EN 60255-26
Emissions	
Conducted emissions: EN 60255-26 Ch. 5.2, CISPR 22	150 kHz...30 MHz
Radiated emissions: EN 60255-26 Ch. 5.1, CISPR 11	30...1 000 MHz
Immunity	
Electrostatic discharge (ESD): EN 60255-26, IEC 61000-4-2	Air discharge 15 kV Contact discharge 8 kV

Electrical fast transients (EFT): EN 60255-26, IEC 61000-4-4	Power supply input 4 kV, 5/50 ns, 5 kHz Other inputs and outputs 4 kV, 5/50 ns, 5 kHz <b>NOTE:</b> Shielded cable required for ethernet communication
Surge: EN 60255-26, IEC 61000-4-5	Between wires: 2 kV, 1.2/50 $\mu$ s Between wire and earth: 4 kV, 1.2/50 $\mu$ s
Radiated RF electromagnetic field: EN 60255-26, IEC 61000-4-3	f = 80...1 000 MHz, 10 V/m
Conducted RF field: EN 60255-26, IEC 61000-4-6	f = 150 kHz...80 MHz, 10 V (RMS)

Table. 8.3 - 286. Voltage tests.

Dielectric voltage test	
EN 60255-27, IEC 60255-5, EN 60255-1	2 kV, 50 Hz, 1 min
Impulse voltage test	
EN 60255-27, IEC 60255-5	5 kV, 1.2/50 $\mu$ s, 0.5 J

## Physical environment compatibility

Table. 8.3 - 287. Mechanical tests.

Vibration test	
EN 60255-1, EN 60255-27, IEC 60255-21-1	2...13.2 Hz, $\pm$ 3.5 mm 13.2...100 Hz, $\pm$ 1.0 g
Shock and bump test	
EN 60255-1, EN 60255-27, IEC 60255-21-2	20 g, 1 000 bumps/dir.

Table. 8.3 - 288. Environmental tests.

Damp heat (cyclic)	
EN 60255-1, IEC 60068-2-30	Operational: +25...+55 °C, 93...97 % (RH), 12+12h
Dry heat	
EN 60255-1, IEC 60068-2-2	Storage: +70 °C, 16 h Operational: +55 °C, 16 h
Cold test	
EN 60255-1, IEC 60068-2-1	Storage: -40 °C, 16 h Operational: -20 °C, 16 h

Table. 8.3 - 289. Environmental conditions.

IP classes
------------

Casing protection class	IP54 (front) IP21 (rear)
<b>Temperature ranges</b>	
Ambient service temperature range	-35...+70 °C
Transport and storage temperature range	-40...+70 °C
<b>Other</b>	
Altitude	<2000 m
Overtoltage category	III
Pollution degree	2

## Casing and package

Table. 8.3 - 290. Dimensions and weight.

<b>Without packaging (net)</b>	
Dimensions	Height: 208 mm Width: 257 mm (½ rack) Depth: 165 mm (no cards or connectors)
Weight	Appr. 3.4 kg
<b>With packaging (gross)</b>	
Dimensions	Height: 250 mm Width: 343 mm Depth: 256 mm
Weight	Appr. 4 kg

## 9 Ordering information

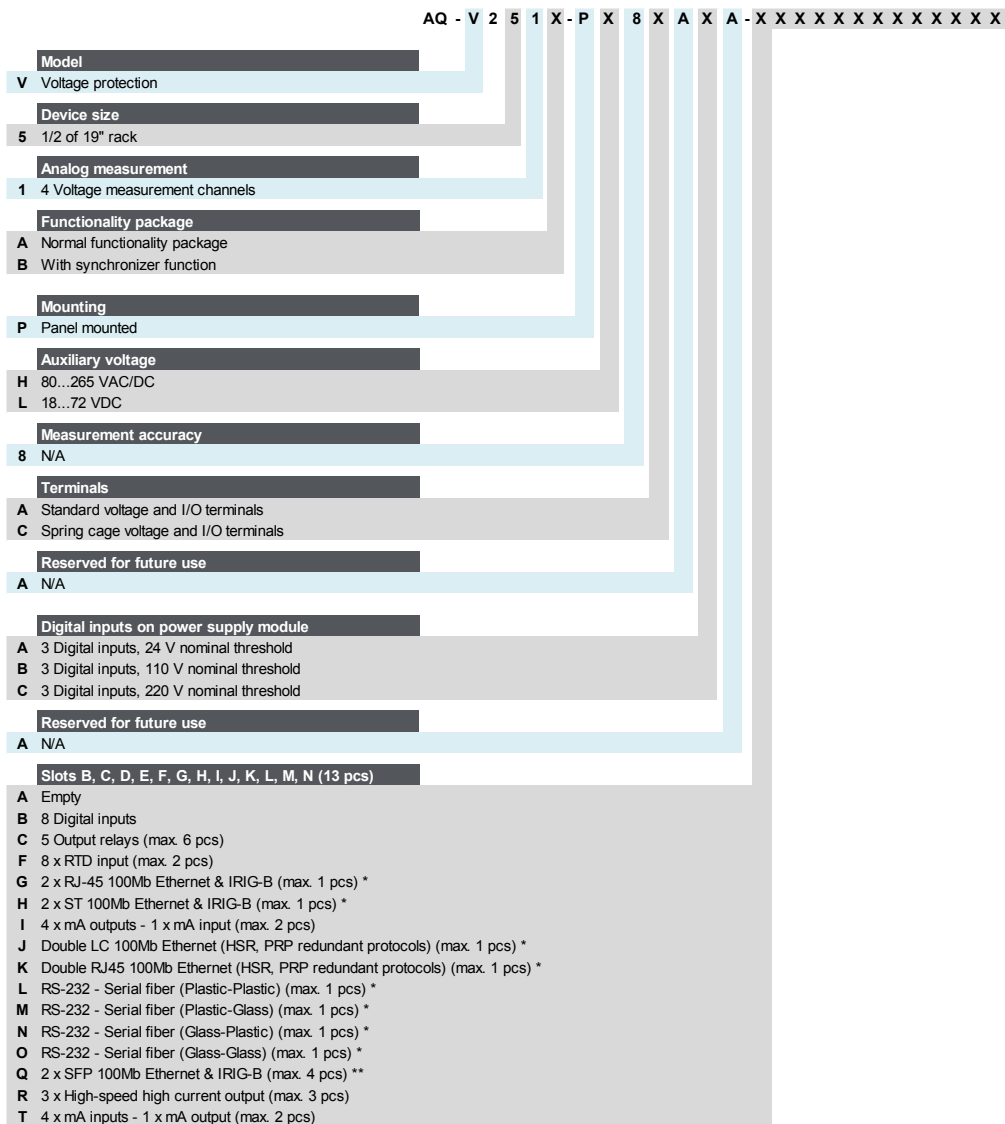

\* Can only be applied to the two last slots.

\*\* Can only be applied to the four last slots. Requires an SFP adapter. See "Accessories" list.

### Accessories

Order code	Description	Note
AX007	External 6-channel 2 or 3 wires RTD Input module, pre-configured	Requires an external 24 VDC supply.
AX008	External 8-ch Thermocouple mA Input module, pre-configured	Requires an external 24 VDC supply.
AX020	SFP module LC 2 km multi-mode	2 km multi-mode fiber (1310 nm)
AX021	SFP module LC 40 km single-mode	40 km single-mode fiber (1310 nm)

AX022	SFP module LC 120 km single-mode	120 km single-mode fiber (1550 nm)
AX013	AQ 250 series raising frame 120mm	-
AQX014	AQ 250 series raising frame 40mm	-
AQX015	AQ 250 series wall mounting bracket	-

## 10 Contact and reference information

### Manufacturer

Arcteq Relays Ltd.

### Visiting and postal address

Kvartsikatu 2 A 1  
65300 Vaasa, Finland

### Contacts

Phone:	+358 10 3221 370
Website:	<a href="http://arcteq.com">arcteq.com</a>
Technical support:	<a href="http://arcteq.com/support-login">arcteq.com/support-login</a> +358 10 3221 388 (EET 9:00 – 17.00)
E-mail (sales):	<a href="mailto:sales@arcteq.com">sales@arcteq.com</a>