

# AQ-T257

Transformer protection device

Instruction manual



## Table of contents

|  |     |
|--|-----|
| 1 Document information .....   | 6   |
| 1.1 Version 2 revision notes .....   | 6   |
| 1.2 Version 1 revision notes .....   | 10  |
| 1.3 Safety information .....   | 11  |
| 1.4 Abbreviations.....   | 12  |
| 2 General .....  | 14  |
| 3 Device user interface.....   | 15  |
| 3.1 Local panel structure .....  | 15  |
| 4 Functions .....  | 17  |
| 4.1 Functions included in AQ-T257 .....  | 17  |
| 4.2 Measurements.....  | 19  |
| 4.2.1 Current measurement and scaling in differential applications .....   | 19  |
| 4.2.2 Voltage measurement and scaling .....  | 31  |
| 4.2.3 Power and energy calculation .....   | 46  |
| 4.2.4 Frequency tracking and scaling .....   | 54  |
| 4.3 General menu.....  | 57  |
| 4.4 Protection functions .....   | 60  |
| 4.4.1 General properties of a protection function .....  | 60  |
| 4.4.2 Non-directional overcurrent protection ( $I>$ ; 50/51).....  | 70  |
| 4.4.3 Non-directional earth fault protection ( $I0>$ ; 50N/51N).....   | 75  |
| 4.4.4 Directional overcurrent protection ( $I_{dir}>$ ; 67).....   | 79  |
| 4.4.5 Directional earth fault protection ( $I0_{dir}>$ ; 67N/32N).....   | 86  |
| 4.4.6 Negative sequence overcurrent/ phase current reversal/ current unbalance protection ( $I2>$ ; 46/46R/46L)..... | 99  |
| 4.4.7 Harmonic overcurrent protection ( $I_h>$ ; 50H/51H/68H).....   | 103 |
| 4.4.8 Circuit breaker failure protection (CBFP; 50BF/52BF) .....   | 110 |
| 4.4.9 Overvoltage protection ( $U>$ ; 59) .....  | 125 |
| 4.4.10 Undervoltage protection ( $U<$ ; 27) .....  | 132 |
| 4.4.11 Neutral overvoltage protection ( $U0>$ ; 59N) .....   | 139 |
| 4.4.12 Sequence voltage protection ( $U1/U2>/<$ ; 47/27P/59PN) .....   | 145 |
| 4.4.13 Overfrequency and underfrequency protection ( $f>/<$ ; 81O/81U).....  | 153 |
| 4.4.14 Rate-of-change of frequency ( $df/dt>/<$ ; 81R) .....   | 157 |
| 4.4.15 Power protection (P, Q, S) $>/<$ ; 32).....   | 162 |
| 4.4.16 Transformer status monitoring.....  | 167 |
| 4.4.17 Generator/motor/transformer differential protection ( $I_{db}>/I_{di}>/I0dHV>/I0dLV>$ ; 87T/87G/87M/87N)..... | 176 |
| 4.4.18 Underimpedance protection ( $Z<$ ; 21U) .....   | 197 |
| 4.4.19 Underexcitation protection ( $X<$ ; 40) .....   | 201 |
| 4.4.20 Volts-per-hertz overexcitation protection ( $V/Hz>$ ; 24) .....   | 205 |
| 4.4.21 Pole slip protection (78) .....   | 212 |
| 4.4.22 Transformer thermal overload protection (TT $>$ ; 49T) .....  | 216 |
| 4.4.23 Resistance temperature detectors (RTD) .....  | 226 |
| 4.4.24 Programmable stage (PSx $>/<$ ; 99).....  | 229 |
| 4.4.25 Arc fault protection ( $I_{Arc}>/I0Arc>$ ; 50Arc/50NArc).....   | 239 |
| 4.5 Control functions .....  | 247 |
| 4.5.1 Common signals.....  | 247 |
| 4.5.2 Automatic voltage regulator (90).....  | 249 |
| 4.5.3 Parallel voltage regulator.....  | 278 |
| 4.5.4 Setting group selection .....  | 287 |
| 4.5.5 Object control and monitoring .....  | 290 |
| 4.5.6 Indicator object monitoring .....  | 302 |
| 4.5.7 Cold load pick-up (CLPU).....  | 304 |

|   |            |
|---|------------|
| 4.5.8 Switch-on-to-fault (SOTF) .....                                   | 313        |
| 4.5.9 Vector jump ( $\Delta\phi$ ; 78) .....                            | 316        |
| 4.5.10 Synchrocheck ( $\Delta V/\Delta a/\Delta f$ ; 25) .....          | 321        |
| 4.5.11 Milliampere output control .....                                 | 334        |
| 4.5.12 Programmable control switch .....                                | 336        |
| 4.5.13 Function buttons .....   | 338        |
| 4.5.14 Analog input scaling curves .....                                | 339        |
| 4.5.15 Logical outputs .....  | 342        |
| 4.5.16 Logical inputs .....   | 343        |
| 4.6 Monitoring functions .....  | 345        |
| 4.6.1 Current transformer supervision .....                             | 345        |
| 4.6.2 Voltage transformer supervision (60) .....                        | 355        |
| 4.6.3 Circuit breaker wear monitoring .....                             | 360        |
| 4.6.4 Current total harmonic distortion (THD) .....                     | 365        |
| 4.6.5 Voltage total harmonic distortion (THD) .....                     | 370        |
| 4.6.6 Fault locator (21FL) .....  | 373        |
| 4.6.7 Measurement recorder .....  | 376        |
| 4.6.8 Fault register .....  | 381        |
| 4.6.9 Event logger .....  | 386        |
| 4.6.10 Disturbance recorder (DR) .....                                  | 387        |
| 4.6.11 User access control.....   | 393        |
| <b>5 Communication .....</b>  | <b>397</b> |
| 5.1 Connections menu.....   | 397        |
| 5.2 Time synchronization .....  | 401        |
| 5.2.1 Internal .....  | 401        |
| 5.2.2 NTP .....   | 401        |
| 5.2.3 PTP .....   | 402        |
| 5.3 Communication protocols .....                                       | 404        |
| 5.3.1 IEC 61850.....  | 404        |
| 5.3.1.1 Logical device mode and logical node mode .....                 | 406        |
| 5.3.1.2 GOOSE .....   | 410        |
| 5.3.2 Modbus TCP and Modbus RTU .....                                   | 414        |
| 5.3.3 IEC 103 .....   | 415        |
| 5.3.4 IEC 101/104 .....   | 416        |
| 5.3.5 SPA .....   | 418        |
| 5.3.6 DNP3 .....  | 419        |
| 5.3.7 Modbus I/O .....  | 422        |
| 5.3.8 OPCUA .....   | 423        |
| 5.3.9 Integration time .....  | 423        |
| 5.4 Analog fault registers .....  | 424        |
| 5.5 Modbus Gateway.....   | 425        |
| <b>6 Connections and application examples.....</b>                      | <b>428</b> |
| 6.1 Connections of AQ-T257 .....  | 428        |
| 6.2 Application example and its connections.....                        | 429        |
| <b>7 Construction and installation .....</b>                            | <b>430</b> |
| 7.1 Construction.....   | 430        |
| 7.2 CPU module .....  | 433        |
| 7.3 Current measurement module .....                                    | 436        |
| 7.4 Voltage measurement module.....                                     | 437        |
| 7.5 Option cards.....   | 438        |
| 7.5.1 Digital input module (optional).....                              | 438        |
| 7.5.2 Digital output module (optional) .....                            | 442        |
| 7.5.3 High-speed and high-current output module (optional).....         | 444        |
| 7.5.4 Milliampere output module (4x mA out & 1x mA in) (optional) ..... | 446        |
| 7.5.5 Milliampere input module (4x mA in & 1x mA out) (optional).....   | 447        |
| 7.5.6 Point sensor arc protection module (optional) .....               | 449        |

|   |            |
|---|------------|
| 7.5.7 RTD input module (optional) .....   | 450        |
| 7.5.8 Double RJ45 Ethernet & IRIG-B communication module (optional) .....   | 451        |
| 7.5.9 Double SFP Ethernet & IRIG-B communication module (optional) .....  | 452        |
| 7.5.10 Double ST 100 Ethernet & IRIG-B communication module (optional) .....  | 453        |
| 7.5.11 Double LC or RJ45 (HSR/PRP) Ethernet communication module (optional) .....                                       | 454        |
| 7.5.12 Serial RS-232 communication module (optional) .....  | 455        |
| 7.6 Dimensions and installation .....   | 456        |
| <b>8 Technical data .....</b>   | <b>459</b> |
| 8.1 Hardware .....  | 459        |
| 8.1.1 Measurements .....  | 459        |
| 8.1.1.1 Current measurement .....   | 459        |
| 8.1.1.2 Voltage measurement .....   | 461        |
| 8.1.1.3 Voltage memory .....  | 461        |
| 8.1.1.4 Power and energy measurement .....  | 462        |
| 8.1.1.5 Frequency measurement .....   | 463        |
| 8.1.2 CPU & Power supply .....  | 463        |
| 8.1.2.1 Auxiliary voltage .....   | 463        |
| 8.1.2.2 CPU communication ports .....   | 464        |
| 8.1.2.3 CPU digital inputs .....  | 465        |
| 8.1.2.4 CPU digital outputs .....   | 465        |
| 8.1.3 Option cards .....  | 466        |
| 8.1.3.1 Digital input module .....  | 466        |
| 8.1.3.2 Digital output module .....   | 467        |
| 8.1.3.3 High-speed and high-current output module .....   | 467        |
| 8.1.3.4 Milliampere output module (4 x mA out & 1 x mA in) .....  | 468        |
| 8.1.3.5 Milliampere input module (1x mA out & 4x mA in) .....   | 469        |
| 8.1.3.6 Point sensor arc protection module .....  | 470        |
| 8.1.3.7 RTD input module .....  | 471        |
| 8.1.3.8 Double RJ-45 Ethernet & IRIG-B communication module .....   | 472        |
| 8.1.3.9 Double SFP Ethernet & IRIG-B communication module .....   | 472        |
| 8.1.3.10 Double ST Ethernet & IRIG-B communication module .....   | 473        |
| 8.1.3.11 Double LC (HSR/PRP) Ethernet communication module .....  | 473        |
| 8.1.3.12 Double RJ-45 (HSR/PRP) Ethernet communication module .....   | 474        |
| 8.1.3.13 RS-232 & serial fiber communication module .....   | 474        |
| 8.1.4 Display .....   | 475        |
| 8.2 Functions .....   | 476        |
| 8.2.1 Protection functions .....  | 476        |
| 8.2.1.1 Non-directional overcurrent protection ( $I>$ ; 50/51) .....  | 476        |
| 8.2.1.2 Non-directional earth fault protection ( $I0>$ ; 50N/51N) .....   | 477        |
| 8.2.1.3 Directional overcurrent protection ( $I_{dir}>$ ; 67) .....   | 478        |
| 8.2.1.4 Directional earth fault protection ( $I0_{dir}>$ ; 67N/32N) .....   | 479        |
| 8.2.1.5 Negative sequence overcurrent/ phase current reversal/ current unbalance protection ( $I2>$ ; 46/46R/46L) ..... | 480        |
| 8.2.1.6 Harmonic overcurrent protection ( $I_h>$ ; 50H/51H/68H) .....   | 481        |
| 8.2.1.7 Circuit breaker failure protection (CBFP; 50BF/52BF) .....  | 482        |
| 8.2.1.8 Overvoltage protection ( $U>$ ; 59) .....   | 483        |
| 8.2.1.9 Undervoltage protection ( $U<$ ; 27) .....  | 484        |
| 8.2.1.10 Neutral overvoltage protection ( $U0>$ ; 59N) .....  | 485        |
| 8.2.1.11 Sequence voltage protection ( $U1/U2>/<$ ; 47/27P/59NP) .....  | 486        |
| 8.2.1.12 Overfrequency and underfrequency protection ( $f>/<$ ; 81O/81U) .....  | 487        |
| 8.2.1.13 Rate-of-change of frequency protection ( $df/dt>/<$ ; 81R) .....   | 488        |
| 8.2.1.14 Power protection (P, Q, S>/< 32) .....   | 489        |
| 8.2.1.15 Transformer thermal overload protection (TT>; 49T) .....   | 490        |
| 8.2.1.16 Underimpedance protection ( $Z<$ ; 21U) .....  | 490        |
| 8.2.1.17 Volts-per-hertz overexcitation protection ( $V/Hz>$ ; 24) .....  | 491        |
| 8.2.1.18 Transformer status monitoring .....  | 492        |
| 8.2.1.19 Resistance temperature detectors (RTD) .....   | 492        |

|  |     |
|--|-----|
| 8.2.1.20 Generator/motor/transformer differential protection ( $I_{db}>/I_{di}>/I_{0dHV}>/I_{0dLV}>$ ;<br>87T/87G/87M/87N) ..... | 493 |
| 8.2.1.21 Arc fault protection ( $I_{Arc}>/I_{0Arc}>$ ; 50Arc/50NArc) (optional) .....  | 494 |
| 8.2.2 Control functions .....  | 495 |
| 8.2.2.1 Automatic voltage regulator (90) .....   | 495 |
| 8.2.2.2 Setting group selection .....  | 496 |
| 8.2.2.3 Object control and monitoring .....  | 496 |
| 8.2.2.4 Indicator object monitoring .....  | 497 |
| 8.2.2.5 Cold load pick-up (CLPU) .....   | 497 |
| 8.2.2.6 Switch-on-to-fault (SOTF) .....  | 498 |
| 8.2.2.7 Vector jump ( $\Delta\phi$ ; 78) .....   | 498 |
| 8.2.2.8 Synchrocheck ( $\Delta V/\Delta a/\Delta f$ ; 25) .....  | 499 |
| 8.2.3 Monitoring functions .....   | 500 |
| 8.2.3.1 Current transformer supervision .....  | 500 |
| 8.2.3.2 Voltage transformer supervision (60) .....   | 501 |
| 8.2.3.3 Circuit breaker wear monitoring .....  | 501 |
| 8.2.3.4 Current total harmonic distortion .....  | 502 |
| 8.2.3.5 Fault locator (21FL) .....   | 503 |
| 8.2.3.6 Event logger .....   | 503 |
| 8.2.3.7 Disturbance recorder .....   | 503 |
| 8.3 Tests and environmental .....  | 504 |
| 9 Ordering information .....   | 507 |
| 10 Contact and reference information .....   | 509 |

## Disclaimer

Please read these instructions carefully before using the equipment or taking any other actions with respect to the equipment. Only trained and qualified persons are allowed to perform installation, operation, service or maintenance of the equipment. Such qualified persons have the responsibility to take all appropriate measures, including e.g. use of authentication, encryption, anti-virus programs, safe switching programs etc. necessary to ensure a safe and secure environment and usability of the equipment. The warranty granted to the equipment remains in force only provided that the instructions contained in this document have been strictly complied with.

Nothing contained in this document shall increase the liability or extend the warranty obligations of the manufacturer Arcteq Relays Ltd. The manufacturer expressly disclaims any and all liability for any damages and/or losses caused due to a failure to comply with the instructions contained herein or caused by persons who do not fulfil the aforementioned requirements. Furthermore, the manufacturer shall not be liable for possible errors in this document.

Please note that you must always comply with applicable local legislation and regulations. The manufacturer gives no warranties that the content of this document is in all respects in line with local laws and regulations and assumes no liability for such possible deviations.

You are advised to notify the manufacturer in case you become aware of any errors in this document or of defects in the equipment.

The manufacturer reserves the right to update or amend this document at any time.

## Copyright

Copyright © Arcteq Relays Ltd. 2026. All rights reserved.

# 1 Document information

## 1.1 Version 2 revision notes

Table. 1.1 - 1. Version 2 revision notes

|          |  |
|----------|--|
| Revision | 2.00   |
| Date     | 6.6.2019   |
| Changes  | <ul style="list-style-type: none"> <li>- New more consistent look.</li> <li>- Improved descriptions generally in many chapters.</li> <li>- Improved readability of a lot of drawings and images.</li> <li>- Updated protection functions included in every manual.</li> <li>- Every protection relay type now has connection drawing, application example drawing with function block diagram and application example with wiring.</li> <li>- Added current measurement side selection description to functions with such feature.</li> <li>- Added General-menu description.</li> </ul> |
| Revision | 2.01   |
| Date     | 6.11.2019  |
| Changes  | <ul style="list-style-type: none"> <li>- Added description for LED test and button test.</li> <li>- Added display sleep timer description.</li> <li>- Complete rewrite of every chapter.</li> <li>- Improvements to many drawings and formula images.</li> <li>- Order codes revised.</li> <li>- Added double ST 100 Mbps Ethernet communication module and Double RJ45 10/100 Mbps Ethernet communication module descriptions</li> </ul>  |
| Revision | 2.02   |
| Date     | 7.7.2020   |
| Changes  | - A number of image descriptions improved.   |
| Revision | 2.03   |
| Date     | 27.8.2020  |

|          |   |
|----------|---|
| Changes  | <ul style="list-style-type: none"> <li>- Terminology consistency improved (e.g. binary inputs are now always called digital inputs).</li> <li>- Tech data modified to be more informative about what type of measurement inputs are used (phase currents/voltages, residual currents/voltages), what component of that measurement is available (RMS, TRMS, peak-to-peak) and possible calculated measurement values (powers, impedances, angles etc.).</li> <li>- Tech data updated: non-directional overcurrent</li> <li>- Tech data updated: non-directional earthfault</li> <li>- Tech data updated: directional earthfault</li> <li>- Tech data updated: current unbalance</li> <li>- Tech data updated: transformer differential</li> <li>- Tech data updated: overfrequency, underfrequency and rate-of-change-of-frequency.</li> <li>- Improvements to many drawings and formula images.</li> <li>- AQ-T257 Functions included list Added: Volts-per-Hertz, voltage memory, indicator objects, switch-on-to-fault, vector jump protection and fault locator.</li> <li>- Added "32N" ANSI code to directional earth fault protection modes "unearthed" and "petersen coil grounded".</li> <li>- Added 6th harmonic to harmonic overcurrent protection function.</li> <li>- Fixed reset ratio of under- and overfrequency protection function from 103 % / 97 % to +/- 20 mHz..</li> <li>- Fixed reset ratio of rate-of-change-of-frequency protection function from 20 mHz/s to 100 mHz/s.</li> <li>- Added BCD and binary input coding description to automatic voltage regulator description.</li> <li>- Changed disturbance recorder maximum digital channel amount from 32 to 95.</li> <li>- Added residual current coarse and fine measurement data to disturbance recorder description.</li> <li>- Event read mode parameter added to Modbus description.</li> <li>- HSO1 and HSO2 connection swapped in arc protection card (was way wrong before).</li> <li>- Updated I01 and I02 rated current range.</li> <li>- Added inches to Dimensions and installation chapter.</li> <li>- Added raising frames, wall mounting bracket, combiflex frame to order code.</li> <li>- Added logical input and logical output function descriptions.</li> <li>- Additions to Abbreviations chapter.</li> <li>- Added button test description to Local panel structure chapter.</li> <li>- Added note to Configuring user levels and passwords chapter that AQ-250 frame units generate a time-stamped event from locking and unlocking user levels.</li> <li>- Added note to Configuring user levels and passwords chapter that user level with a password automatically locks itself after 30 minutes of inactivity.</li> <li>- Added more "Tripped stage" indications and fault types to Measurement value recorder function.</li> <li>- Updated: Digital input activation and release threshold setting ranges and added drop-off delay setting.</li> <li>- Added sample rate to voltage and current measurement tech data.</li> <li>- Fixed overvoltage, undervoltage, neutral overvoltage and sequence voltage stage misspelled IDMT curve formula.</li> <li>- Note added to power protection tech data.</li> </ul> |
| Revision | 2.04  |
| Date     | 8.6.2021  |
| Changes  | <ul style="list-style-type: none"> <li>- Increased the consistency in terminology</li> <li>- Various image upgrades</li> <li>- Visual update to the order codes</li> </ul>  |
| Revision | 2.05  |
| Date     | 22.6.2021   |

|          |  |
|----------|--|
| Changes  | <ul style="list-style-type: none"> <li>- Fixed phase current measurement continuous thermal withstand from 30A to 20A.</li> <li>- Fixed lots of timing errors written to registers table. "Prefault" is -200 ms from Start event, "Pretrigger" is -20 ms from trip (or start if fault doesn't progress to trip), "Fault" is start (or trip if fault doesn't progress to trip).</li> <li>- Added event history technical data</li> </ul>  |
| Revision | 2.06   |
| Date     | 21.6.2022  |
| Changes  | <ul style="list-style-type: none"> <li>- Improved descriptions generally in many chapters.</li> <li>- Improved readability of a lot of drawings and images.</li> <li>- Order codes have been revised.</li> <li>- Added pole slip function description.</li> <li>- Added LN mode parameters to all functions (On, Blocked, Test, Test/Blocked, Off).</li> <li>- Added color themes parameter description.</li> <li>- Improved color sleep mode description.</li> <li>- Improved alarm function color behavior description and images.</li> <li>- Added operation time with different measurement values vs setting ratio in instant operation mode to non-directional overcurrent function description.</li> <li>- Fixed bias calculation formula for restricted earth fault function. Was correctly in the code, just written wrong in the manual.</li> <li>- Added power measurement side selection to power functions.</li> <li>- Added synchrocheck start check parameter description.</li> <li>- Added 30 s pretriggering time for disturbance recorder (AQ-250 devices only).</li> <li>- Added new trip detections and fault types to measurement value recorder.</li> <li>- Added user description parameter descriptions for digital inputs, digital outputs, logical inputs, logical outputs and GOOSE inputs.</li> <li>- Arc point sensor HSO1 and HSO2 position fixed.</li> <li>- Added spare part codes and compatibilities to option cards.</li> </ul> |
| Revision | 2.07   |
| Date     | 7.7.2022   |
| Changes  | <ul style="list-style-type: none"> <li>- Added <a href="#">THD voltage measurements</a>.</li> <li>- Fixed number of <a href="#">logical inputs</a>.</li> <li>- Added <a href="#">common signals</a> function description.</li> <li>- Added <a href="#">PTP time synchronization</a> description.</li> <li>- Added <a href="#">Modbus Gateway</a> description.</li> </ul>   |
| Revision | 2.08   |
| Date     | 8.9.2022   |
| Changes  | <ul style="list-style-type: none"> <li>- Added stage forcing parameter to function descriptions.</li> <li>- Fixes to "Real time signals to comm" description.</li> <li>- Added "Ethernet port" parameter description to <a href="#">IEC61850</a>, <a href="#">IEC104</a> and <a href="#">Modbus TCP</a> descriptions.</li> <li>- Removed "Measurement update interval" settings from Modbus description. No longer in use.</li> <li>- Renamed "System integration" chapter to "<a href="#">Communication</a>" and restructured the chapters to be closer to how they are in the menus.</li> <li>- Added "<a href="#">Event logger</a>" chapter.</li> <li>- Added more descriptions to new IEC 61850 ed2 GOOSE parameters.</li> <li>- Added "Condition monitoring / CB wear" description to object description.</li> <li>- Added "<a href="#">User button</a>" description.</li> <li>- Added logical device and logical node mode descriptions.</li> </ul>  |

|          |  |
|----------|--|
| Revision | 2.09   |
| Date     | 14.3.2023  |
| Changes  | <ul style="list-style-type: none"> <li>- Updated the Arcteq logo on the cover page and refined the manual's visual look.</li> <li>- Added the "<a href="#">Safety information</a>" chapter and changed the notes throughout the document accordingly.</li> <li>- Changed the "IED user interface" chapter's title to "Device user interface" and replaced all 'IED' terms with 'device' or 'unit'.</li> <li>- Updated the rated values for the change-over CPU digital outputs in "Technical data".</li> <li>- Updated the input impedance for the voltage measurement module in "<a href="#">Technical data</a>".</li> <li>- Added double ethernet port configuration parameters to "<a href="#">Connections menu</a>" chapter.</li> <li>- Added event overload detection description to "<a href="#">Event logger</a>" chapter.</li> </ul> |
| Revision | 2.10   |
| Date     | 19.6.2023  |
| Changes  | - Updated order codes.   |
| Revision | 2.11   |
| Date     | 29.11.2023   |
| Changes  | <ul style="list-style-type: none"> <li>- Added the 5 ms update time in the measurement chapters.</li> <li>- Added spring lock cage options for connectors. See the "<a href="#">Ordering information</a>" chapter.</li> <li>- Added <a href="#">underexcitation protection (X&lt;; 40)</a>.</li> <li>- Added <a href="#">underimpedance protection function</a>.</li> <li>- Added <a href="#">cold load pick-up function</a>.</li> <li>- Updated the contact address for technical support in the "<a href="#">Contact and reference information</a>" chapter.</li> <li>- Circuit breaker wear is not integrated to the <a href="#">objects</a>.</li> </ul>  |
| Revision | 2.12   |
| Date     | January 2024   |
| Changes  | - Added Chinese and Kazakh languages as language options in " <a href="#">General menu</a> ".  |
| Revision | 2.13   |
| Date     | September 2024   |
| Changes  | <ul style="list-style-type: none"> <li>- Added 5th harmonic maximum uptime parameter to transformer differential protection function.</li> <li>- Corrected the number of devices that fit a 19 in rack in the "<a href="#">Dimensions and installation</a>" chapter.</li> </ul>  |
| Revision | 2.14   |
| Date     | June 2025  |

|          |   |
|----------|---|
| Changes  | <ul style="list-style-type: none"> <li>- Increased phase current measurement range. See the current measurement section in the <a href="#">Technical data</a> chapter.</li> <li>- Added clarification that transformer differential protection can be used for motor differential protection.</li> <li>- Fixed inverse time delay formula in <a href="#">Automatic voltage regulator</a> description.</li> <li>- Updated the product and packaging weights.</li> <li>- Added new "<a href="#">User access control</a>" description.</li> <li>- Added "<a href="#">parallel mode</a>" description for automatic voltage regulator function.</li> <li>- Added circuit breaker wear to "<a href="#">Object control and monitoring</a>" description.</li> <li>- Added "<a href="#">High-speed and high-current output</a>" option card description.</li> <li>- Added "<a href="#">Milliampere input module (4x mA in &amp; 1x mA out)</a>" option card description.</li> <li>- Added "<a href="#">Double SFP Ethernet &amp; IRIG-B communication module</a>" option card description.</li> <li>- <a href="#">Order code</a> table updated.</li> </ul> |
| Revision | 2.15  |
| Date     | January 2026  |
| Changes  | <ul style="list-style-type: none"> <li>- Updated the input tables in the "<a href="#">Automatic voltage regulator</a>" chapter.</li> <li>- Updated the Connections images.</li> <li>- Updated the make-and-carry of the <a href="#">Point sensor arc protection module</a>.</li> </ul>  |
| Revision | 2.16  |
| Date     | June 2026   |
| Changes  | <ul style="list-style-type: none"> <li>- General improvements to descriptions.</li> <li>- IEC61850 <a href="#">integration time</a> description improved.</li> <li>- Added <a href="#">CBW abrasion (SCBR) calculation</a> description.</li> <li>- Added measurements to <a href="#">Programmable stages</a>.</li> <li>- Added <a href="#">OPCUA</a> communication protocol.</li> </ul>   |

## 1.2 Version 1 revision notes

Table. 1.2 - 2. Version 1 revision notes

|          |  |
|----------|--|
| Revision | 1.00   |
| Date     | 13.4.2016  |
| Changes  | <ul style="list-style-type: none"> <li>• The first revision for AQ-T256 and T257.</li> </ul>                                 |
| Revision | 1.01   |
| Date     | 10.2.2017  |
| Changes  | <ul style="list-style-type: none"> <li>• Added the programmable stage description.</li> <li>• Order code updated.</li> </ul> |
| Revision | 1.02   |
| Date     | 9.1.2018   |

|          |  |
|----------|--|
| Changes  | <ul style="list-style-type: none"> <li>• Measurement value recorder description added.</li> <li>• ZCT connection added to the current measurement description.</li> <li>• Internal harmonics blocking added to the I&gt; and IO&gt; function descriptions.</li> <li>• Non-standard delay curves added.</li> <li>• Event lists revised on several functions.</li> <li>• RTD &amp; mA card description improved.</li> <li>• Ring-lug CT card option description added.</li> <li>• New U&gt; and U&lt; function measurement modes documented.</li> <li>• Order code revised.</li> </ul> |
| Revision | 1.03   |
| Date     | 14.8.2018  |
| Changes  | <ul style="list-style-type: none"> <li>• Added the mA output option card description and updated the order code.</li> <li>• Added the HMI display technical data.</li> </ul>   |

### 1.3 Safety information

This document contains important instructions that should be saved for future use. Read the document carefully before installing, operating, servicing, or maintaining this equipment. Please read and follow all the instructions carefully to prevent accidents, injury and damage to property.

Additionally, this document may contain four (4) types of special messages to call the reader's attention to useful information as follows:



**NOTICE!**

"Notice" messages indicate relevant factors and conditions to the concept discussed in the text, as well as to other relevant advice.



**CAUTION!**

"Caution" messages indicate a potentially hazardous situation which, if not avoided, **could** result in minor or moderate personal injury, in equipment/property damage, or software corruption.



**WARNING!**

"Warning" messages indicate a potentially hazardous situation which, if not avoided, **could** result in death or serious personal injury as well as serious damage to equipment/property.



**DANGER!**

"Danger" messages indicate an imminently hazardous situation which, if not avoided, **will** result in death or serious personal injury.

These symbols are added throughout the document to ensure all users' personal safety and to avoid unintentional damage to the equipment or connected devices.

Please note that although these warnings relate to direct damage to personnel and/or equipment, it should be understood that operating damaged equipment may also lead to further, indirect damage to personnel and/or equipment. Therefore, we expect any user to fully comply with these special messages.

## 1.4 Abbreviations

|      |                                       |
|------|---------------------------------------|
| AI   | – Analog input                        |
| AR   | – Auto-recloser                       |
| ASDU | – Application service data unit       |
| AVR  | – Automatic voltage regulator         |
| BCD  | – Binary-coded decimal                |
| CB   | – Circuit breaker                     |
| CBFP | – Circuit breaker failure protection  |
| CLPU | – Cold load pick-up                   |
| CPU  | – Central processing unit             |
| CT   | – Current transformer                 |
| CTM  | – Current transformer module          |
| CTS  | – Current transformer supervision     |
| DG   | – Distributed generation              |
| DHCP | – Dynamic Host Configuration Protocol |
| DI   | – Digital input                       |
| DO   | – Digital output                      |
| DOL  | – Direct-on-line                      |
| DR   | – Disturbance recorder                |
| DT   | – Definite time                       |
| FF   | – Fundamental frequency               |
| FFT  | – Fast Fourier transform              |
| FTP  | – File Transfer Protocol              |
| GI   | – General interrogation               |
| HMI  | – Human-machine interface             |
| HR   | – Holding register                    |
| HV   | – High voltage                        |
| HW   | – Hardware                            |
| IDMT | – Inverse definite minimum time       |
| IGBT | – Insulated-gate bipolar transistor   |

I/O – Input and output

IRIG-B – Inter-range instruction group, timecode B

LCD – Liquid-crystal display

LED – Light emitting diode

LV – Low voltage

NC – Normally closed

NO – Normally open

NTP – Network Time Protocol

RMS – Root mean square

RSTP – Rapid Spanning Tree Protocol

RTD – Resistance temperature detector

RTU – Remote terminal unit

SCADA – Supervisory control and data acquisition

SG – Setting group

SOTF – Switch-on-to-fault

SW – Software

THD – Total harmonic distortion

TRMS – True root mean square

VT – Voltage transformer

VTM – Voltage transformer module

VTS – Voltage transformer supervision

## 2 General

## 3 Device user interface

### 3.1 Local panel structure

The front panel of AQ-250 series devices have multiple LEDs, control buttons and a local RJ-45 Ethernet port for configuration. Each unit is also equipped with an RS-485 serial interface and an RJ-45 Ethernet interface on the back of the device.

Figure. 3.1 - 1. Local panel structure.

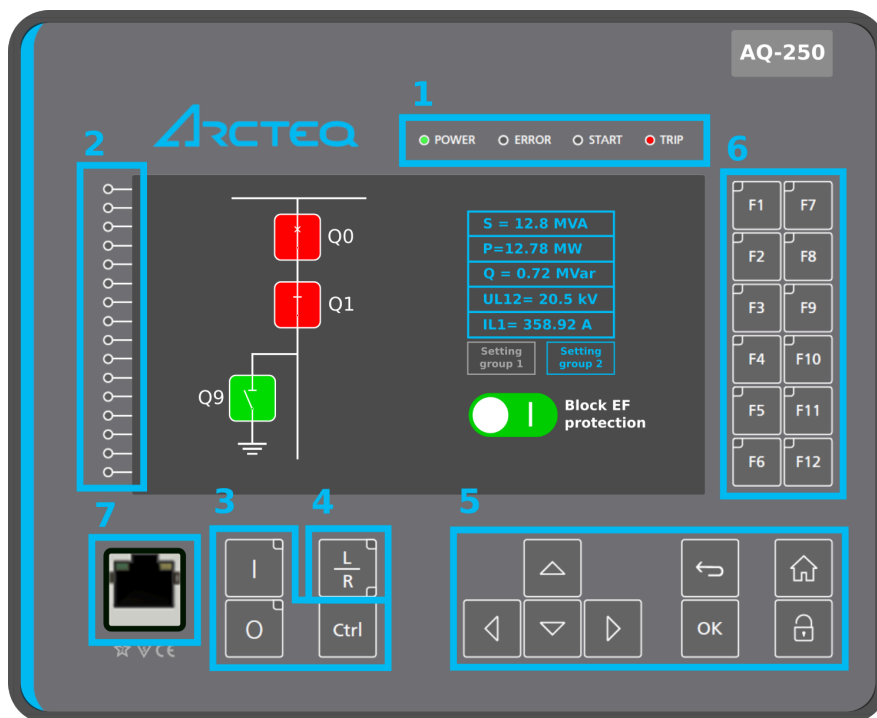

1. Four (4) default LEDs: "Power", "Error", "Start" (configurable) and "Trip" (configurable).
2. Sixteen (16) freely configurable LEDs (red, orange, green) with programmable legend texts.
3. Three (3) object control buttons: Choose the controllable object with the Ctrl button and control the breaker or other object with the I and the O buttons.
4. The L/R button switches between the local and the remote control modes.
5. Eight (8) buttons for device local programming: the four navigation arrows, the Back and the OK buttons, the Home and the password activation buttons).
6. Twelve (12) freely configurable function buttons (F1...F12). Each button has a freely configurable LED (red, orange, green).
7. One (1) RJ-45 Ethernet port for device configuration.

When the unit is powered on, the green "Power" LED is lit. When the red "Error" LED is lit, the device has an internal (hardware or software) error that affects the operation of the unit. The activation of the yellow "Start" LED and the red "Trip" LED are based on the setting the user has put in place in the software.

The sixteen freely configurable LEDs are located on the left side of the display. Their activation and color (green, orange, red) are based on the settings the user has put in place in the software.

The view in the screen is freely configurable. Virtual switches and buttons can be added which can be used to change the setting groups or control the device's general logic locally or remotely. The status of the object (circuit breaker, disconnecter) can be displayed on the screen. All measured and calculated values regardless of the magnitude category (current, voltage, power, energy, frequency, etc.) can be shown on the screen.

Holding the I (object control) button down for five seconds brings up the button test menu. It displays all the physical buttons on the front panel. Pressing any of the listed buttons marks them as tested. When all buttons are marked as having been tested, the device will return back to the default view.

## 4 Functions

### 4.1 Functions included in AQ-T257

The AQ-T257 transformer protection device includes the following functions as well as the number of stages in those functions.

Table. 4.1 - 3. Protection functions of AQ-T257.

| Name      | IEC  | ANSI    | Description                                 |
|-----------|--|---------|---|
| NOC (4)   | I><br>I>><br>I>>><br>I>>>>   | 50/51   | Non-directional overcurrent protection      |
| DOC (4)   | I <sub>dir</sub> ><br>I <sub>dir</sub> >><br>I <sub>dir</sub> >>><br>I <sub>dir</sub> >>>>     | 67      | Directional overcurrent protection          |
| NEF (4)   | I0><br>I0>><br>I0>>><br>I0>>>>   | 50N/51N | Non-directional earth fault protection      |
| DEF (4)   | I0 <sub>dir</sub> ><br>I0 <sub>dir</sub> >><br>I0 <sub>dir</sub> >>><br>I0 <sub>dir</sub> >>>> | 67N/32N | Directional earth fault protection          |
| OV (4)    | U><br>U>><br>U>>><br>U>>>>   | 59      | Overvoltage protection                      |
| UV (4)    | U<<br>U<<<br>U<<<<br>U<<<<   | 27      | Undervoltage protection                     |
| NOV (4)   | U0><br>U0>><br>U0>>><br>U0>>>>   | 59N     | Neutral overvoltage protection              |
| FRQV (8)  | f><br>f>><br>f>>><br>f>>>><br>f<<br>f<<<br>f<<<<br>f<<<<                                       | 81O/81U | Overfrequency and underfrequency protection |
| ROCOF (8) | df/dt>/< (1...8)   | 81R     | Rate-of-change of frequency                 |

| Name         | IEC   | ANSI                | Description   |
|--------------|---|---------------------|---|
| CUB (4)      | I2><br>I2>><br>I2>>><br>I2>>>>  | 46/46R/46L          | Negative sequence overcurrent/<br>phase current reversal/<br>current unbalance protection                   |
| VUB (4)      | U1/U2>/<<br>U1/U2>>/<<<br>U1/U2>>>/<<<<br>U1/U2>>>>/<<<<                    | 47/27P/59PN         | Sequence voltage protection   |
| HOC (4)      | Ih><br>Ih>><br>Ih>>><br>Ih>>>>  | 50H/51H/<br>68H     | Harmonic overcurrent protection   |
| CBFP (1)     | CBFP  | 50BF/52BF           | Circuit breaker failure protection  |
| PQS (4)      | P, Q, S>/<<br>P, Q, S>>/<<<br>P, Q, S>>>/<<<<br>P, Q, S>>>>/<<<<            | 32                  | Power protection  |
| TRF          | -   | -                   | Transformer status monitoring   |
| DIF (1)      | I <sub>db</sub> >/I <sub>di</sub> >/I <sub>0dHV</sub> >/I <sub>0dLV</sub> > | 87T/87G/<br>87M/87N | Generator/ motor / transformer differential protection<br>with integrated restricted earth fault protection |
| TOLT (1)     | TT>   | 49T                 | Transformer thermal overload protection   |
| VHZ (1)      | V/Hz>   | 24                  | Volts-per-hertz overexcitation protection   |
| OOS (1)      | Pslip   | 78                  | Pole slip protection  |
| UIM (2)      | Z<<br>Z<<   | 21U                 | Underimpedance protection   |
| URX (2)      | X<<br>X<<   | 21/40               | Underreactance protection   |
| RTD (1...16) | -   | -                   | RTD alarms (Resistance temperature detector)  |
| PGS (1)      | PGx>/<  | 99                  | Programmable stage  |
| ARC (1)      | I <sub>Arc</sub> >/I <sub>0Arc</sub> >                                      | 50Arc/<br>50NArc    | Arc fault protection (optional)   |

Table. 4.1 - 4. Control functions of AQ-T257.

| Name | IEC | ANSI | Description  |
|------|-----|------|--|
| SGS  | -   | -    | Setting group selection<br>(8 setting groups available)  |
| OBJ  | -   | -    | Object control and monitoring<br>(10 objects available)  |
| CIN  | -   | -    | Indicator object monitoring<br>(10 indicators available) |

| Name | IEC                          | ANSI | Description  |
|------|------------------------------|------|--|
| CLPU | CLPU                         | -    | Cold load pick-up  |
| SOTF | SOTF                         | -    | Switch-on-to-fault   |
| VJP  | $\Delta\phi$                 | 78   | Vector jump  |
| SYN  | $\Delta V/\Delta a/\Delta f$ | 25   | Synchrocheck   |
| VRG  | -                            | 90   | Automatic voltage regulator (independent or parallel) ( <u>only</u> included in Function package B!) |

Table. 4.1 - 5. Monitoring functions of AQ-T257.

| Name    | IEC | ANSI | Description                        |
|---------|-----|------|------------------------------------|
| CTS (2) | -   | -    | Current transformer supervision    |
| VTS     | -   | 60   | Voltage transformer supervision    |
| DR      | -   | -    | Disturbance recorder               |
| FLX     | -   | 21FL | Fault locator                      |
| THD     | -   | -    | Current total harmonic distortion. |
| THDV    | -   | -    | Voltage total harmonic distortion. |
| CBW     | -   | -    | Circuit breaker wear monitor       |
| MREC    | -   | -    | Measurement recorder               |
| VREC    | -   | -    | Fault register                     |

## 4.2 Measurements

### 4.2.1 Current measurement and scaling in differential applications

The current measurement module (CT module, or CTM) is used for measuring the currents from current transformers. The current measurements are updated every 5 milliseconds. The measured values are processed into the measurement database and they are used by measurement and protection functions. It is essential to understand the concept of current measurements to be able to get correct measurements.

Figure. 4.2.1 - 2. Current measurement terminology.

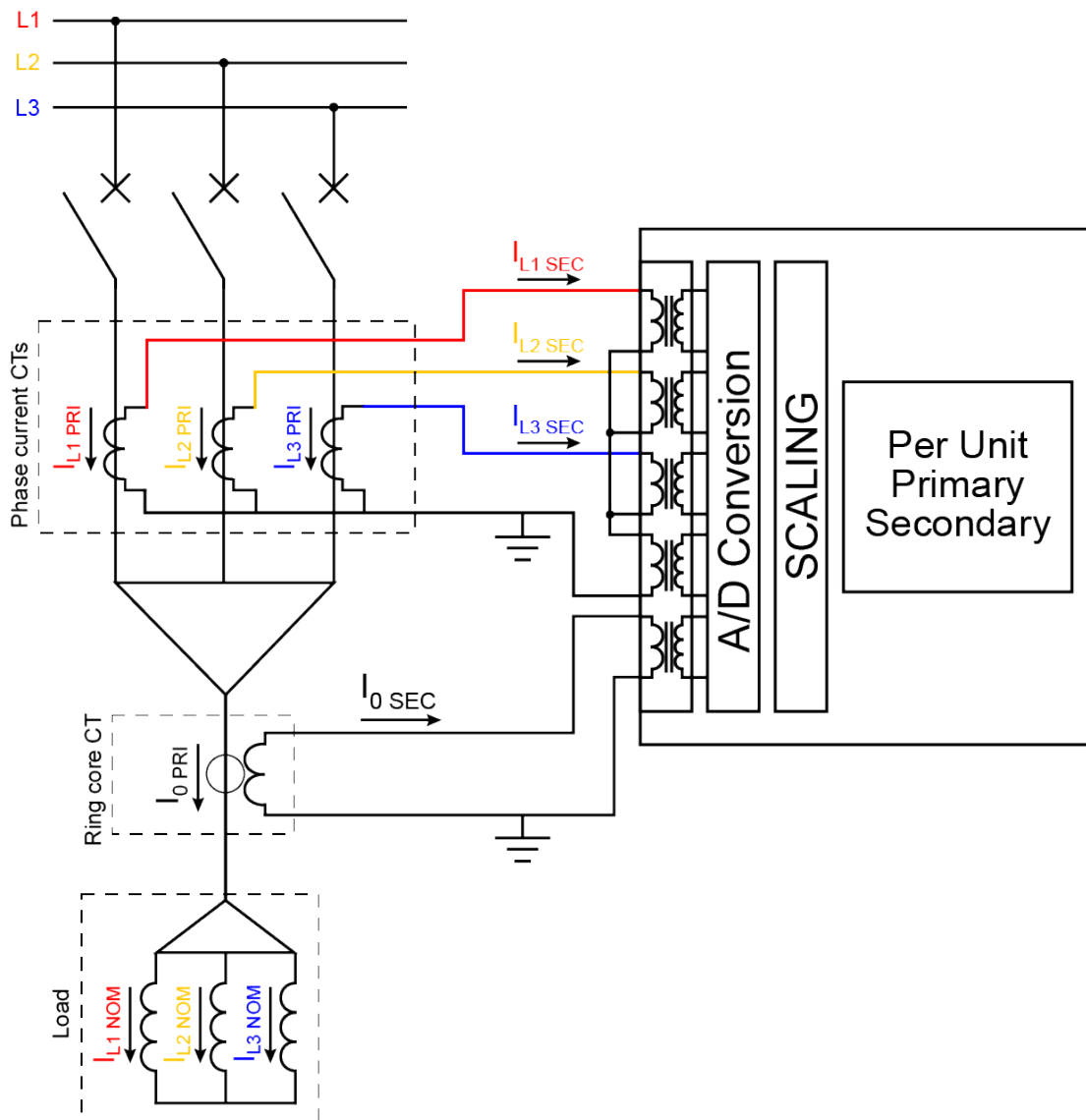

**PRI:** The primary current, i.e. the current which flows in the primary circuit and through the primary side of the current transformer.

**SEC:** The secondary current, i.e. the current which the current transformer transforms according to its ratios. This current is measured by the device.

**NOM:** The nominal primary current of the protected transformer. The nominal current on the HV side differs from that on the LV side according to the transformer voltage ratio. The nominal current is calculated based on the transformer's MVA and the nominal voltage on each winding.

For the measurements to be correct the user needs to ensure that the measurement signals are connected to the correct inputs, that the current direction is connected correctly, and that the scaling is set correctly.

The device calculates the scaling factors based on the set values of the CT primary, the CT secondary and the nominal current. The device measures the secondary current, the current output from the current transformer installed into application's primary circuit. The rated primary and secondary currents of the CT need to be set for the device to "know" the primary and per-unit values. In power transformers, the protected unit's nominal current in both windings is calculated based on the given nominal power (MVA) and the nominal voltage. The settings can only give the apparatus nominal in p.u. (per-unit) when the nominal current is known. Also, knowing what the transformer's nominal current is makes the unit protection much easier and more straightforward to configure. In modern protection devices this scaling calculation is done internally after the current transformer's primary current, secondary current and machine nominal current are set.

Figure. 4.2.1 - 3. Nominal current calculation in differential protection devices.

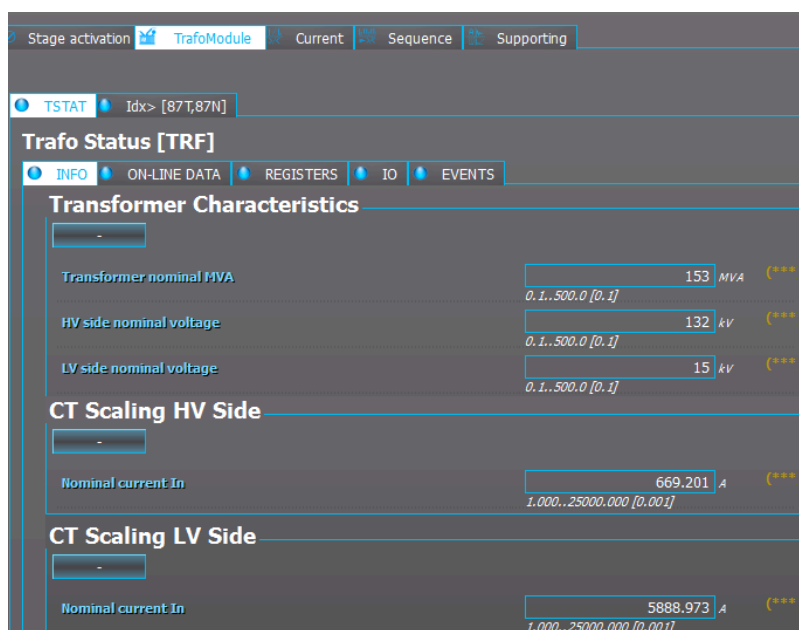

### Example of CT scaling (application 1)

The following figure presents how CTs are connected to the device's measurement inputs. It also shows the CT ratings and the transformer nominal current. Note that S1 is always connected to an odd connector regardless of the CT direction. The CT direction is selected in the settings of the transformer differential protection function.

Figure. 4.2.1 - 4. Connections (application 1).

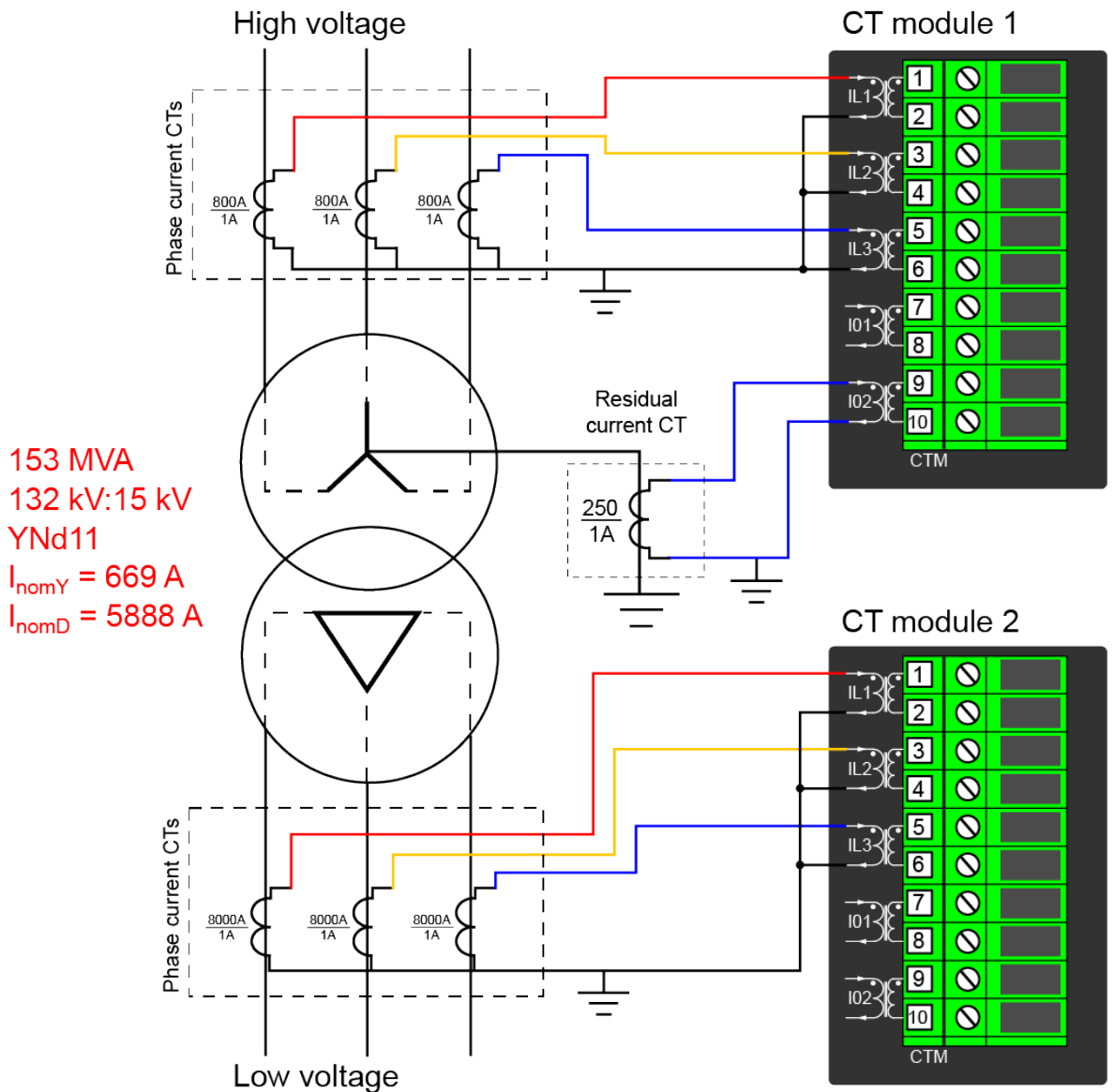

Because of the direction of the CTs and because the CTs' P1/S1 side is always wired to the modules' odd inputs, the "Differential calculation mode" setting has to be set to "Subtract" (*Protection* → *TrafoModule* → *Idx* > [87T,87N] → *Settings*). This way the direction of the measured currents are checked correctly from the device's perspective.

The following table presents the initial data of the connection as well as the ratings.

Table. 4.2.1 - 6. Initial data.

|  |   |  |
|--|---|--|
| <p><b>High-voltage side CT:</b></p> <ul style="list-style-type: none"> <li>CT primary: 800 A</li> <li>CT secondary: 1 A</li> </ul> <p>High-voltage side nominal current:<br/>669 A</p> | <p><b>Ring core CT in Input I02:</b></p> <ul style="list-style-type: none"> <li>3I0CT primary: 250 A</li> <li>3I0CT secondary: 1 A</li> </ul> | <p><b>Low-voltage side CT:</b></p> <ul style="list-style-type: none"> <li>CT primary: 8 000 A</li> <li>CT secondary: 1 A</li> </ul> <p>Low-voltage side nominal current:<br/>5 888 A</p> |
| <ul style="list-style-type: none"> <li>Both CTs are pointing through the transformer (HV-S2 and LV-S2 are pointing in the same direction).</li> </ul>                                  |   |  |

The nominal current for both the HV and LV sides of the protected transformer are calculated based on the values set in the *Transformer characteristics* menu (*Protection* → *TrafoModule* → *TSTAT* → *INFO*). The ratio between the CT modules 1 and 2 can be set in their respective tabs at *Measurement* → *Transformers*. The per-unit scaling ("Scale meas. to In") is automatically set to "Object in p.u." in all machine protection devices and it cannot be changed.

Figure. 4.2.1 - 5. Phase CT scaling to machine nominal.

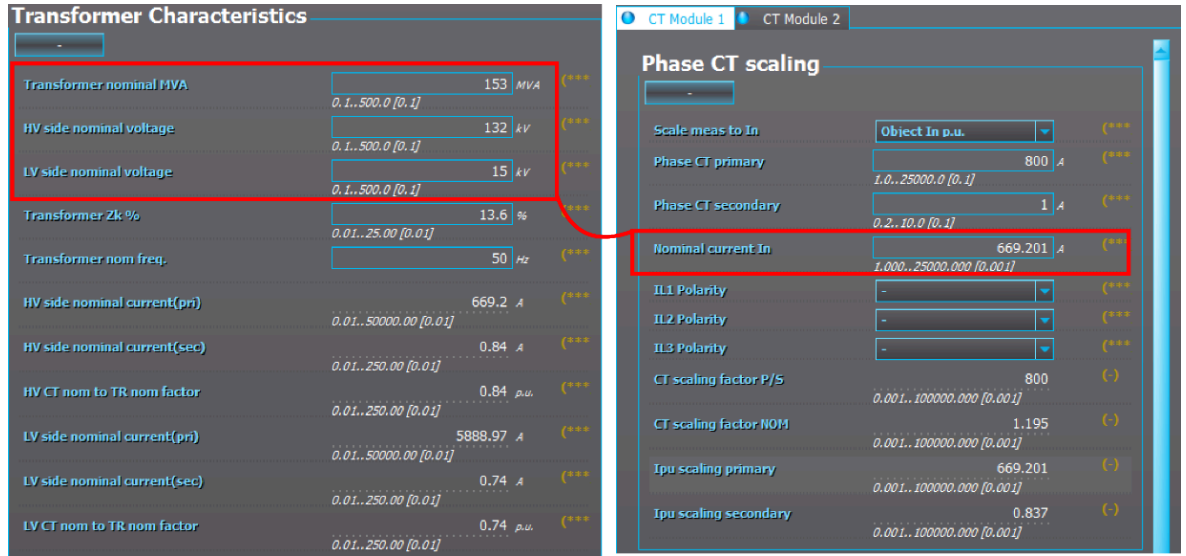

As seen in the image above, device calculates both the HV side nominal current (669.2 A) and the LV side nominal current (5,888.97 A). The nominal current calculations are done according to the following formulas:

$$\text{HV side nominal current (pri)} = \frac{\text{trafo}_{\text{nom}}/\sqrt{3}}{U_{\text{HV}}/\sqrt{3}} = \frac{153\,000\,000/\sqrt{3}}{132\,000/\sqrt{3}} \approx 669.201 \text{ A}$$

$$\text{LV side nominal current (pri)} = \frac{\text{trafo}_{\text{nom}}/\sqrt{3}}{U_{\text{LV}}/\sqrt{3}} = \frac{153\,000\,000/\sqrt{3}}{15\,000/\sqrt{3}} \approx 5888.97 \text{ A}$$

The HV and LV side nominal current can also be calculated in per unit values as follows:

$$\text{HV CT nom to TR nom factor} = \frac{\text{HV side nominal current (pri)}}{\text{Phase CT primary}} = \frac{669.2 \text{ A}}{800 \text{ A}} \approx 0.84 \text{ p. u.}$$

$$\text{LV CT nom to TR nom factor} = \frac{\text{LV side nominal current (pri)}}{\text{Phase CT primary}} = \frac{5888.97 \text{ A}}{8000 \text{ A}} \approx 0.74 \text{ p. u.}$$

The secondary nominal current (in amperes) is the result of multiplying the per unit value with the phase CT secondary side current. This current can be used when the unit is commissioned and when the directions of CTs are checked. See the example calculation below:

$$\begin{aligned} &\text{HV side nominal current (sec)} \\ &= \text{HV CT nom to TR nom factor} \times \text{Phase CT secondary} = 0.84 \text{ p. u.} \times 1 \text{ A} = 0.84 \text{ A} \end{aligned}$$

$$\begin{aligned} &\text{LV side nominal current (sec)} \\ &= \text{LV CT nom to TR nom factor} \times \text{Phase CT secondary} = 0.74 \text{ p. u.} \times 1 \text{ A} = 0.74 \text{ A} \end{aligned}$$

In case the phase current CTs are connected to the module via a Holmgren (summing) connection, the use of coarse residual current measurement settings is required: the "I01 CT" settings are set according to the phase current CTs' ratings (800/1 A).

Figure. 4.2.1 - 6. Residual I01 CT scaling (coarse).

| Setting               | Value | Unit | Range             | Resolution | Warning |
|-----------------------|-------|------|-------------------|------------|---------|
| I01 CT primary        | 800   | A    | 0.20..25000.00    | [0.10]     | ***     |
| I01 CT secondary      | 1     | A    | 0.10..10.00       | [0.10]     | ***     |
| I01 Polarity          | -     |      |                   |            | ***     |
| CT scaling factor P/S | 800   |      | 0.001..100000.000 | [0.001]    | (-)     |

The residual current CT is connected to the first CTM directly, which requires the use of sensitive residual current measurement settings: the "Residual I02 CT scaling" settings are set according to the residual current CT's ratings (250/1 A).

Figure. 4.2.1 - 7. Residual I02 CT scaling (sensitive).

| Setting               | Value | Unit | Range             | Resolution | Warning |
|-----------------------|-------|------|-------------------|------------|---------|
| I02 CT primary        | 250   | A    | 0.20..25000.00    | [0.10]     | ***     |
| I02 CT secondary      | 1     | A    | 0.10..10.00       | [0.10]     | ***     |
| I02 Polarity          | -     |      |                   |            | ***     |
| CT scaling factor P/S | 250   |      | 0.001..100000.000 | [0.001]    | (-)     |

### Example of CT scaling (application 2)

The following figure presents how the CTs are connected to the device's measurement inputs. It also shows the CT ratings and the transformer nominal current. Note that S1 is always connected to an odd connector regardless of the CT direction. The CT direction is selected in the settings of the transformer differential protection function.

Figure. 4.2.1 - 8. Connections (application 2).

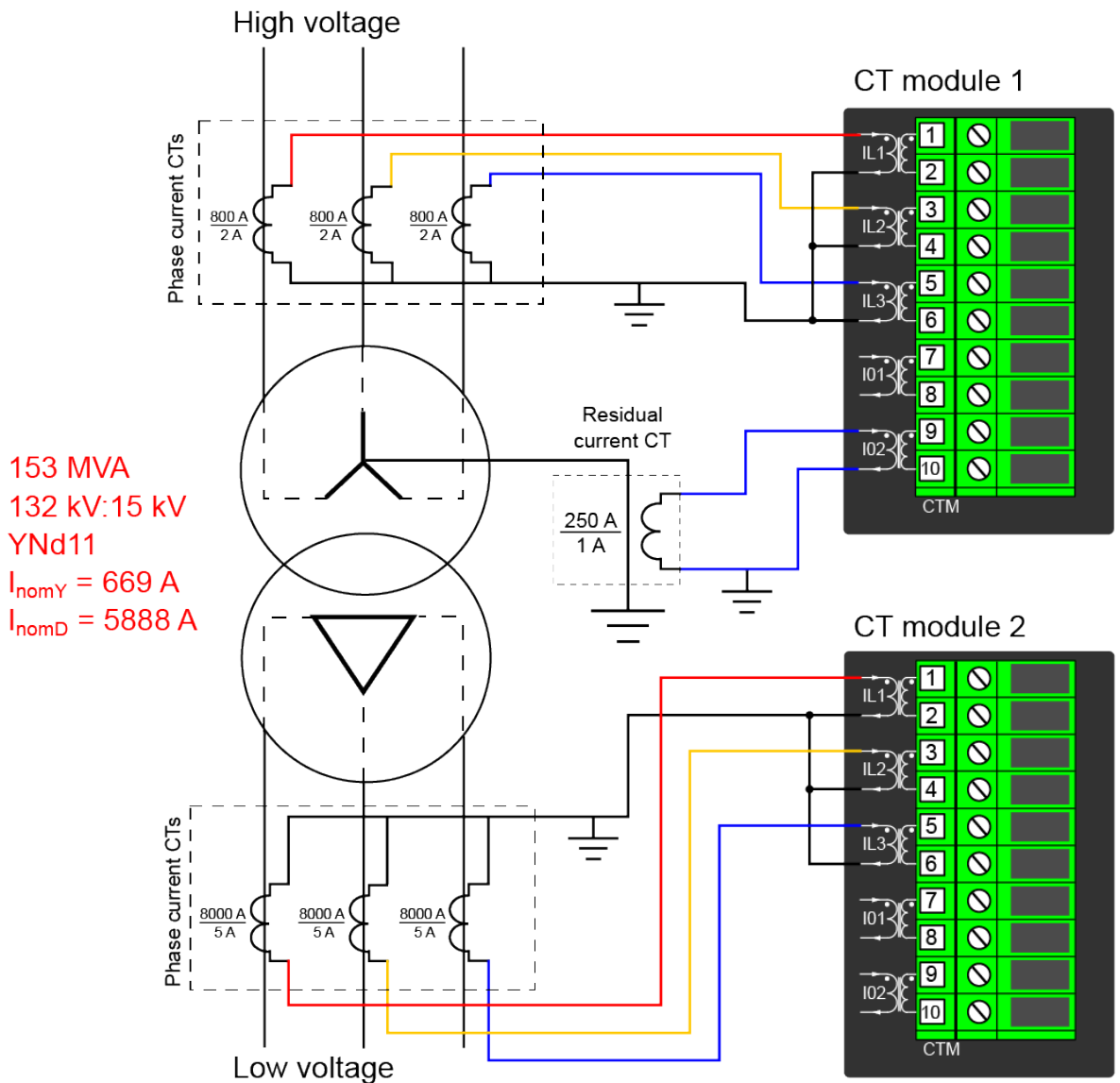

Because of the direction of the CTs and because the CTs' P1/S1 side is always wired to the modules' odd inputs, the "Differential calculation mode" has to be set to "Add" (*Protection* → *TrafoModule* → *Idx* → [87T,87N] → *Settings*). The difference with the first application is that here the CTs point towards the protected object instead of pointing through it.

The following table presents the initial data of the connection as well as the ratings.

Table. 4.2.1 - 7. Initial data.

|  |   |  |
|--|---|--|
| Machine nominal power: 153 MVA<br>Machine high voltage side nominal amplitude: 132 kV<br>Machine low voltage side nominal amplitude: 15 kV                                     |   |  |
| <b>High voltage side CT:</b> <ul style="list-style-type: none"> <li>CT primary: 800 A</li> <li>CT secondary: 2 A</li> </ul> <b>High-voltage side nominal current:</b><br>669 A | <b>Residual current CT in Input I02:</b> <ul style="list-style-type: none"> <li>3I0CT primary: 250 A</li> <li>3I0CT secondary: 1 A</li> </ul> | <b>Low voltage side CT.</b> <ul style="list-style-type: none"> <li>CT primary: 8 000 A</li> <li>CT secondary: 5 A</li> </ul> <b>Low-voltage side nominal current:</b><br>5 888 A |

- Both CTs are pointing towards the protected object (HV-S2 and LV-S2 are pointing at each other).

The nominal currents on both the HV and the LV sides are the same as in Application 1. However, the CTs' secondary current levels have been changed to 2 A (on the HV side) and to 5 A (on the LV side). The nominal currents are still calculated the same way:

$$\text{HV side nominal current (pri)} = \frac{\text{trafo}_{nom}/3}{U_{HV}/\sqrt{3}} = \frac{153\,000\,000/3}{132\,000/\sqrt{3}} \approx 669.201 \text{ A}$$

$$\text{LV side nominal current (pri)} = \frac{\text{trafo}_{nom}/3}{U_{LV}/\sqrt{3}} = \frac{153\,000\,000/3}{15\,000/\sqrt{3}} \approx 5888.97 \text{ A}$$

The HV and LV side nominal current can also be calculated in per unit values as follows:

$$\text{HV CT nom to TR nom factor} = \frac{\text{HV side nominal current (pri)}}{\text{Phase CT primary}} = \frac{669.2 \text{ A}}{800 \text{ A}} \approx 0.84 \text{ p. u.}$$

$$\text{LV CT nom to TR nom factor} = \frac{\text{LV side nominal current (pri)}}{\text{Phase CT primary}} = \frac{5888.97 \text{ A}}{8000 \text{ A}} \approx 0.74 \text{ p. u.}$$

The secondary nominal current (in amperes) is the result of multiplying the per unit value with the phase CT secondary side current. This current can be used when the unit is commissioned and when the directions of CTs are checked. In Application 2 it is necessary to inject higher amplitudes to the CTs via the secondary injection tool in order to reach the nominal currents. See the example calculation below:

**HV side nominal current (sec)**

$$= \text{HV CT nom to TR nom factor} \times \text{Phase CT secondary} = 0.84 \text{ p. u.} \times 2 \text{ A} = 1.68 \text{ A}$$

**LV side nominal current (sec)**

$$= \text{LV CT nom to TR nom factor} \times \text{Phase CT secondary} = 0.74 \text{ p. u.} \times 5 \text{ A} = 3.70 \text{ A}$$

## Settings

Table. 4.2.1 - 8. Settings of the Phase CT scaling.

| Name                    | Unit | Range   | Step  | Default   | Description   |
|-------------------------|------|---|-------|---|---|
| Scale measurement to In | -    | <ul style="list-style-type: none"> <li>• CT nom p.u.</li> <li>• Object In p.u.</li> </ul> | -     | <ul style="list-style-type: none"> <li>• CT nom p.u.</li> </ul> | <p>The selection of the reference used in the device's per-unit system scaling. Either the set phase current CT primary or the protected object's nominal current.</p> <div style="border: 1px solid yellow; padding: 5px; display: inline-block;">  <p><b>CAUTION!</b><br/>Not applicable in machine protection!</p> </div> |
| Phase CT primary        | A    | 1...25 000  | 0.001 | 100   | The rated primary current of the current transformer.   |

| Name                  | Unit | Range   | Step  | Default | Description  |
|-----------------------|------|---|-------|---------|--|
| Phase CT secondary    | A    | 0.2...10  | 0.001 | 5       | The rated secondary current of the current transformer.  |
| Nominal current In    | A    | 1...25 000  | 0.001 | 100     | The nominal current of the protected object. This setting is only visible if the option "Object In p.u." has been selected in the "Scale meas. to In" setting.   |
| IL1 Polarity          | -    | <ul style="list-style-type: none"> <li>• -</li> <li>• Invert</li> </ul> | -     | • -     | The selection of the first current measurement channel's (IL1) polarity (direction). The default setting is for the positive current to flow from connector 1 to connector 2, with the secondary currents' starpoint pointing towards the line.  |
| IL2 Polarity          | -    | <ul style="list-style-type: none"> <li>• -</li> <li>• Invert</li> </ul> | -     | • -     | The selection of the second current measurement channel's (IL2) polarity (direction). The default setting is for the positive current to flow from connector 3 to connector 4, with the secondary currents' starpoint pointing towards the line. |
| IL3 Polarity          | -    | <ul style="list-style-type: none"> <li>• -</li> <li>• Invert</li> </ul> | -     | • -     | The selection of the third current measurement channel's (IL3) polarity (direction). The default setting is for the positive current to flow from connector 5 to connector 6, with the secondary currents' starpoint pointing towards the line.  |
| CT scaling factor P/S | -    | -   | -     | -       | A feedback value; the calculated scaling factor that is the ratio between the primary current and the secondary current.   |
| CT scaling factor NOM | -    | -   | -     | -       | A feedback value; the calculated scaling factor that is the ratio between the set primary current and the set nominal current.   |
| Ipu scaling primary   | -    | -   | -     | -       | A feedback value; the scaling factor for the primary current's per-unit value.   |
| Ipu scaling secondary | -    | -   | -     | -       | A feedback value; the scaling factor for the secondary current's per-unit value.   |

Table. 4.2.1 - 9. Settings of the Residual I01 CT scaling.

| Name             | Unit | Range        | Step     | Default | Description   |
|------------------|------|--------------|----------|---------|---|
| I01 CT primary   | A    | 0.2...25 000 | 0.000 01 | 100     | The rated primary current of the current transformer.   |
| I01 CT secondary | A    | 0.1...10     | 0.000 01 | 1.0     | The rated secondary current of the current transformer. |

| Name                  | Unit | Range   | Step | Default | Description   |
|-----------------------|------|---|------|---------|---|
| I01 Polarity          | -    | <ul style="list-style-type: none"> <li>• -</li> <li>• Invert</li> </ul> | -    | -       | The selection of the coarse residual measurement channel's (I01) polarity (direction). The default setting is for the positive current to flow from connector 7 to connector 8. |
| CT scaling factor P/S | -    | -   | -    | -       | A feedback value; the calculated scaling factor that is the ratio between the primary current and the secondary current.  |

Table. 4.2.1 - 10. Settings of the Residual I02 CT scaling.

| Name                  | Unit | Range   | Step        | Default | Description   |
|-----------------------|------|---|-------------|---------|---|
| I02 CT primary        | A    | 1...25 000  | 0.000<br>01 | 100     | The rated primary current of the current transformer.   |
| I02 CT secondary      | A    | 0.001...10  | 0.000<br>01 | 0.2     | The rated secondary current of the current transformer.   |
| I02 Polarity          | -    | <ul style="list-style-type: none"> <li>• -</li> <li>• Invert</li> </ul> | -           | -       | The selection of the sensitive residual measurement channel's (I02) polarity (direction). The default setting is for the positive current to flow from connector 9 to connector 10. |
| CT scaling factor P/S | -    | -   | -           | -       | A feedback value; the calculated scaling factor that is the ratio between the primary current and the secondary current.  |

## Measurements

The following measurements are available in the measured current channels.

Table. 4.2.1 - 11. Per-unit phase current measurements.

| Name              | Unit | Range                | Step  | Description  |
|-------------------|------|----------------------|-------|--|
| Pha.curr.ILx      | × In | 0.000...1<br>250.000 | 0.001 | The RMS current measurement (in p.u.) from each of the phase current channels.   |
| Pha.curr.ILx TRMS | × In | 0.000...1<br>250.000 | 0.001 | The TRMS current (inc. harmonics up to 31 <sup>st</sup> ) measurement (in p.u.) from each of the phase current channels. |
| P-P curr.ILx      | × In | 0.000...500.000      | 0.001 | The peak-to-peak current measurement (in p.u.) from each of the phase current channels.                                  |

Table. 4.2.1 - 12. Primary phase current measurements.

| Name                  | Unit | Range                    | Step  | Description  |
|-----------------------|------|--------------------------|-------|--|
| Pri.Pha.curr.ILx      | A    | 0.000...1<br>000 000.000 | 0.001 | The primary RMS current measurement from each of the phase current channels.   |
| Pha.curr.ILx TRMS Pri | A    | 0.000...1<br>000 000.000 | 0.001 | The primary TRMS current (inc. harmonics up to 31 <sup>st</sup> ) measurement from each of the phase current channels. |

Table. 4.2.1 - 13. Secondary phase current measurements.

| Name                     | Unit | Range           | Step  | Description  |
|--------------------------|------|-----------------|-------|--|
| Sec.Pha.curr.ILx         | A    | 0.000...300.000 | 0.001 | The primary RMS current measurement from each of the phase current channels.   |
| Pha.curr.ILx<br>TRMS Sec | A    | 0.000...300.000 | 0.001 | The primary TRMS current (inc. harmonics up to 31 <sup>st</sup> ) measurement from each of the phase current channels. |

Table. 4.2.1 - 14. Phase current angle measurements.

| Name             | Unit | Range           | Step  | Description  |
|------------------|------|-----------------|-------|--|
| Pha.angle<br>ILx | deg  | 0.000...360.000 | 0.001 | The phase angle measurement from each of the three phase current inputs. |

Table. 4.2.1 - 15. Per-unit residual current measurements.

| Name                 | Unit | Range                | Step  | Description   |
|----------------------|------|----------------------|-------|---|
| Res.curr.I0x         | × In | 0.000...1<br>250.000 | 0.001 | The RMS current measurement (in p.u.) from the residual current channel I01 or I02.   |
| Calculated<br>I0     | × In | 0.000...1<br>250.000 | 0.001 | The RMS current measurement (in p.u.) from the calculated I0 current channel.   |
| Res.curr.I0x<br>TRMS | × In | 0.000...1<br>250.000 | 0.001 | The TRMS current (inc. harmonics up to 31 <sup>st</sup> ) measurement (in p.u.) from the residual current channel I01 or I02. |
| P-P curr.I0x         | × In | 0.000...500.000      | 0.001 | The peak-to-peak current measurement (in p.u.) from the residual current channel I01 or I02.                                  |

Table. 4.2.1 - 16. Primary residual current measurements.

| Name                     | Unit | Range                       | Step  | Description   |
|--------------------------|------|-----------------------------|-------|---|
| Pri.Res.curr.I0x         | A    | 0.000...1<br>000<br>000.000 | 0.001 | The primary RMS current measurement from the residual current channel I01 or I02.   |
| Pri.calc.I0              | A    | 0.000...1<br>000<br>000.000 | 0.001 | The primary RMS current measurement from the calculated current channel I0.   |
| Res.curr.I01<br>TRMS Pri | A    | 0.000...1<br>000<br>000.000 | 0.001 | The TRMS current (inc. harmonics up to 31 <sup>st</sup> ) measurement from the primary residual current channel I01 or I02. |

Table. 4.2.1 - 17. Secondary residual current measurements.

| Name             | Unit | Range           | Step  | Description   |
|------------------|------|-----------------|-------|---|
| Sec.Res.curr.I0x | A    | 0.000...300.000 | 0.001 | The secondary RMS current measurement from the residual current channel I01 or I02. |

| Name                  | Unit | Range           | Step  | Description   |
|-----------------------|------|-----------------|-------|---|
| Sec.calc.I0           | A    | 0.000...300.000 | 0.001 | The secondary RMS current measurement from the calculated current channel I0.   |
| Res.curr.I0x TRMS Sec | A    | 0.000...300.000 | 0.001 | The secondary TRMS current (inc. harmonics up to 31 <sup>st</sup> ) measurement from the secondary residual current channel I01 or I02. |

Table. 4.2.1 - 18. Residual current phase angle measurements.

| Name                | Unit | Range           | Step  | Description   |
|---------------------|------|-----------------|-------|---|
| Res.curr.angle I0x  | deg  | 0.000...360.000 | 0.001 | The residual current angle measurement from the I01 or I02 current input. |
| Calculated I0 angle | deg  | 0.000...360.000 | 0.001 | The calculated residual current angle measurement.                        |

Table. 4.2.1 - 19. Per-unit sequence current measurements.

| Name                    | Unit | Range             | Step  | Description  |
|-------------------------|------|-------------------|-------|--|
| Positive sequence curr. | × In | 0.00...1<br>250.0 | 0.001 | The measurement (in p.u.) from the calculated positive sequence current. |
| Negative sequence curr. | × In | 0.00...1<br>250.0 | 0.001 | The measurement (in p.u.) from the calculated negative sequence current. |
| Zero sequence curr.     | × In | 0.00...1<br>250.0 | 0.001 | The measurement (in p.u.) from the calculated zero sequence current.     |

Table. 4.2.1 - 20. Primary sequence current measurements.

| Name                        | Unit | Range                 | Step  | Description  |
|-----------------------------|------|-----------------------|-------|--|
| Pri.Positive sequence curr. | A    | 0.00...1 000<br>000.0 | 0.001 | The primary measurement from the calculated positive sequence current. |
| Pri.Negative sequence curr. | A    | 0.00...1 000<br>000.0 | 0.001 | The primary measurement from the calculated negative sequence current. |
| Pri.Zero sequence curr.     | A    | 0.00...1 000<br>000.0 | 0.001 | The primary measurement from the calculated zero sequence current.     |

Table. 4.2.1 - 21. Secondary sequence current measurements.

| Name                        | Unit | Range           | Step  | Description  |
|-----------------------------|------|-----------------|-------|--|
| Sec.Positive sequence curr. | A    | 0.000...300.000 | 0.001 | The secondary measurement from the calculated positive sequence current. |
| Sec.Negative sequence curr. | A    | 0.000...300.000 | 0.001 | The secondary measurement from the calculated negative sequence current. |

| Name                    | Unit | Range           | Step  | Description  |
|-------------------------|------|-----------------|-------|--|
| Sec.Zero sequence curr. | A    | 0.000...300.000 | 0.001 | The secondary measurement from the calculated zero sequence current. |

Table. 4.2.1 - 22. Sequence phase angle measurements.

| Name                         | Unit | Range         | Step  | Description                                     |
|------------------------------|------|---------------|-------|---|
| Positive sequence curr.angle | deg  | 0.000...360.0 | 0.001 | The calculated positive sequence current angle. |
| Negative sequence curr.angle | deg  | 0.000...360.0 | 0.001 | The calculated negative sequence current angle. |
| Zero sequence curr.angle     | deg  | 0.000...360.0 | 0.001 | The calculated zero sequence current angle.     |

Table. 4.2.1 - 23. Harmonic current measurements.

| Name   | Unit | Range  | Step  | Default  | Description   |
|--|------|--|-------|----------|---|
| Harm Abs.pr Perc.  | -    | <ul style="list-style-type: none"> <li>Percent</li> <li>Absolute</li> </ul>                        | -     | Percent  | Defines whether the harmonics are calculated as percentage or absolute values.  |
| Harmonics display  | -    | <ul style="list-style-type: none"> <li>Per unit</li> <li>Primary A</li> <li>Secondary A</li> </ul> | -     | Per unit | Defines how the harmonics are displayed: in p.u. values, as primary current values, or as secondary current values.   |
| IxxMaximum harmonic  | A    | 0.000...1 000 000.000  | 0.001 | -        | Displays the maximum harmonics value of the selected current input ILx or IOx.  |
| Ixx fundamental  | A    | 0.000...1 000 000.000  | 0.001 | -        | Displays the current value of the fundamental frequency measurement (RMS) from the selected current input ILx or IOx. |
| Ixx harmonics (2 <sup>nd</sup> ...31 <sup>st</sup> harmonic) | A    | 0.000...1 000 000.000  | 0.001 | -        | Displays the selected harmonic from the current input ILx or IOx.   |

## 4.2.2 Voltage measurement and scaling

The voltage measurement module (VT module, or VTM) is used for measuring the voltages from voltage transformers. The voltage measurements are updated every 5 milliseconds. The measured values are processed into the measurement database and they are used by measurement and protection functions. It is essential to understand the concept of voltage measurements to be able to get correct measurements.

Figure. 4.2.2 - 9. Voltage measurement terminology

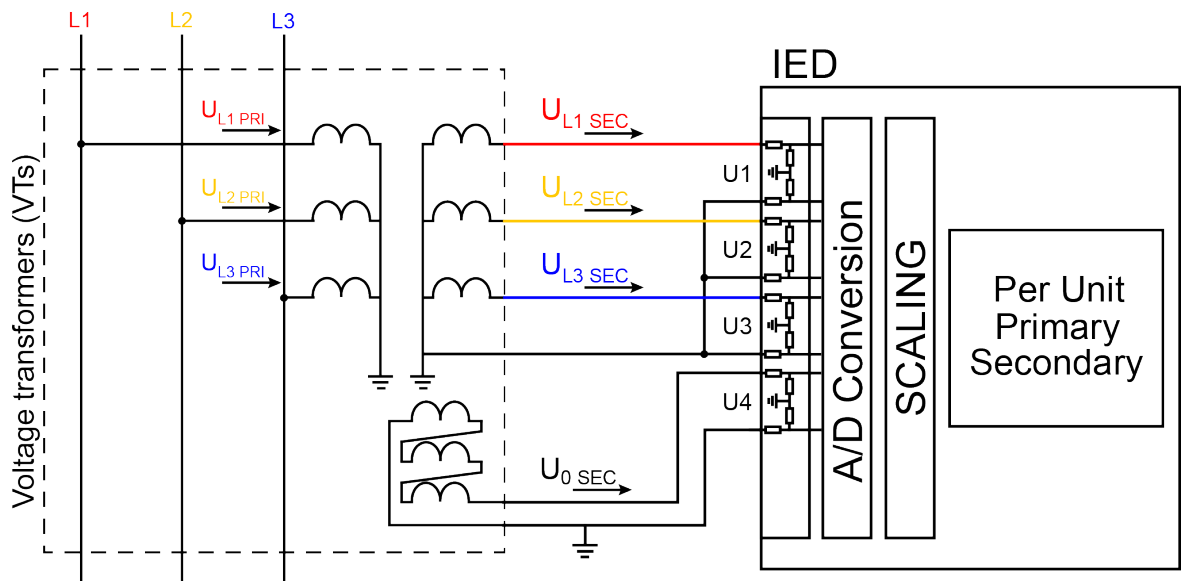

**PRI:** The primary voltage, i.e. the voltage in the primary circuit which is connected to the primary side of the voltage transformer.

**SEC:** The secondary voltage, i.e. the voltage which the voltage transformer transforms according to the ratio. This voltage is measured by the device.

For the measurements to be correct the user needs to ensure that the measurement signals are connected to the correct inputs, that the voltage direction is correct, and that the scaling is set correctly.

The device calculates the scaling factors based on the set VT primary, and secondary voltage values. The device measures secondary voltages, which are the voltage outputs from the VT installed into the application's primary circuit. The voltage can be measured directly from the system as well (up to 400 V nominal line-to-neutral voltage). When connecting voltage directly, measuring mode must be set to 3LN+U4 mode. The rated primary and secondary voltages of the VT need to be set for the device to "know" the primary and per-unit values. In modern protection devices this scaling calculation is done internally after the voltage transformer's primary and secondary voltages are set.

Normally, the primary line-to-line voltage rating for VTs is 400 V...60 kV, while the secondary voltage ratings are 100 V...210 V. Non-standard ratings can also be directly connected as the scaling settings are flexible and have large ranges.

### Example of VT scaling

The following figure presents how VTs are connected to the device's measurement inputs. It also shows the VT ratings. In the figure below, three line-to-neutral voltages are connected along with the zero sequence voltage; therefore, the 3LN+U4 mode must be selected and the U4 channel must be set as U0. Other possible connections are presented later in this chapter.

Figure. 4.2.2 - 10. Connections.

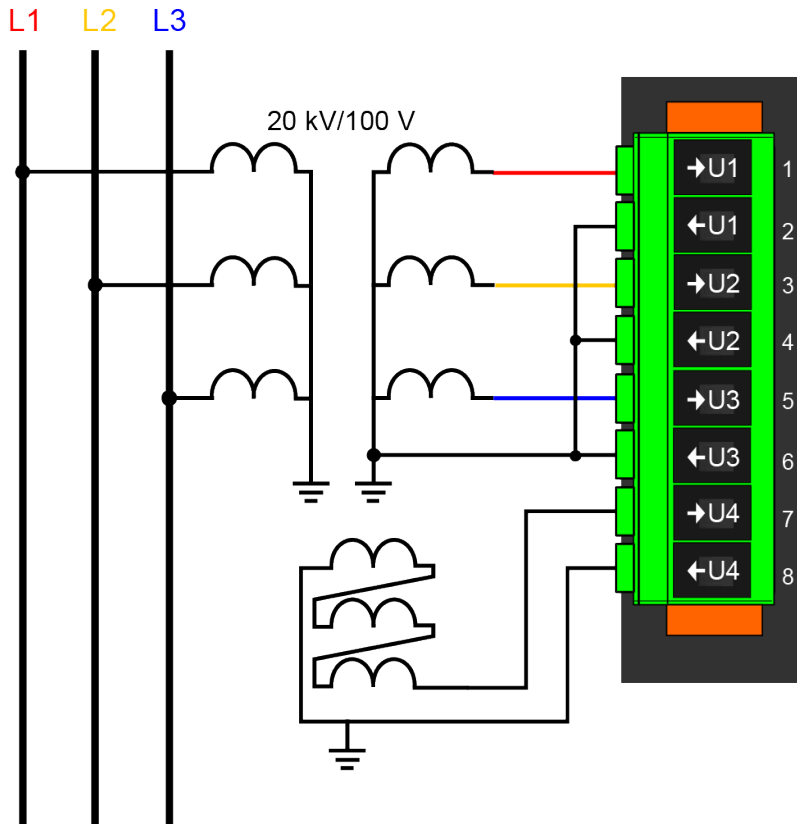

The following table presents the initial data of the connection.

Table. 4.2.2 - 24. Initial data.

|   |  |
|---|--|
| <b>Phase voltage VT</b><br>- VT primary: 20 000 V<br>- VT secondary: 100 V  | <b>Zero sequence voltage VT</b><br>- U4 VT primary: 20 000 V<br>- U4 VT secondary: 100 V |
| - the zero sequence voltage is connected similarly to line-to-neutral voltages (+U0).<br>- in case wiring is incorrect, all polarities can be individually switched by 180 degrees in the device. |  |

Once the settings have been sent to the device, device calculates the scaling factors and displays them for the user. The "VT scaling factor P/S" describes the ratio between the primary voltage and the secondary voltage. The per-unit scaling factors ("VT scaling factor p.u.") for both primary and secondary values are also displayed.

There are several different ways to use all four voltage channels. The voltage measurement modes are the following:

- 3LN+U4 (three line-to-neutral voltages and U4 can be used for either zero sequence voltage or synchrochecking)
- 3LL+U4 (three line-to-line voltages and U4 can be used either for zero sequence voltage or synchrochecking)
- 2LL+U3+U4 (two line-to-line voltages and the U3 and the U4 channels can be used for synchrochecking, zero sequence voltage, or for both)

The 3LN+U0 is the most common voltage measurement mode. See below for example connections of voltage line-to-line measurement (3LL on the left, 2LL on the right).

Figure. 4.2.2 - 11. Example connections for voltage line-to-line measurement.

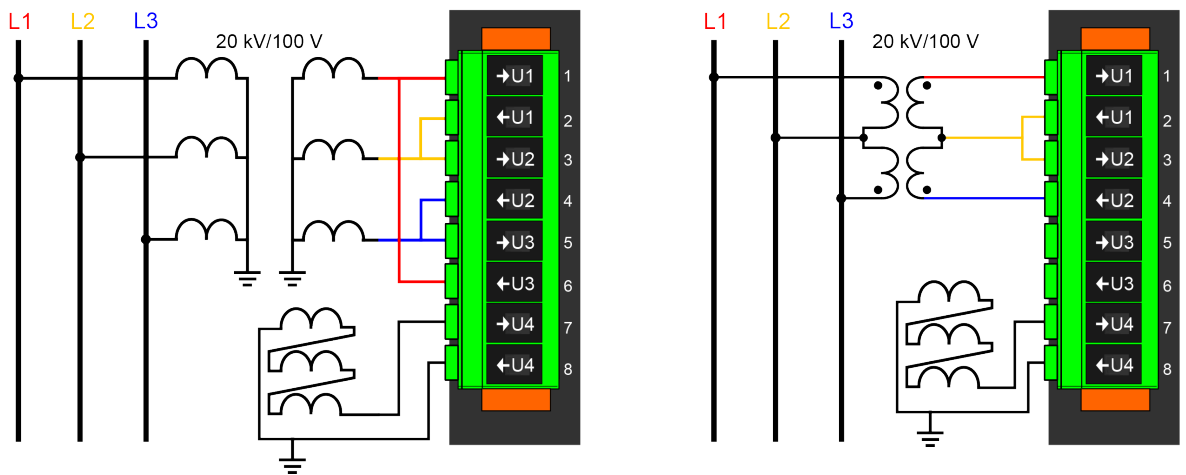

If only two line-to-line voltages are measured, the third one ( $U_{L31}$ ) is calculated based on the  $U_{L12}$  and  $U_{L23}$  vectors. When measuring line-to-line voltages, the line-to-neutral voltages can also be calculated as long as the value of  $U_0$  is measured.

The voltage measurement channel U4 can be used to measure the zero sequence voltage ( $U_0$ ), the side 2 voltage of the circuit breaker (Synchrocheck), or for automatic voltage regulator function. If the 2LL+U3+U4 mode is selected, the third channel (U3) can be used for this purpose. Please note that  $U_0$  can only be measured by using a single channel.

In the image below is an example of 2LL+U0+SS, that is, two line-to-line measurements with the zero sequence voltage and voltage from side 2 for Synchrocheck. Since  $U_0$  is available, line-to-neutral voltages can be calculated.

Figure. 4.2.2 - 12. 2LL+U0+SS settings and connections.

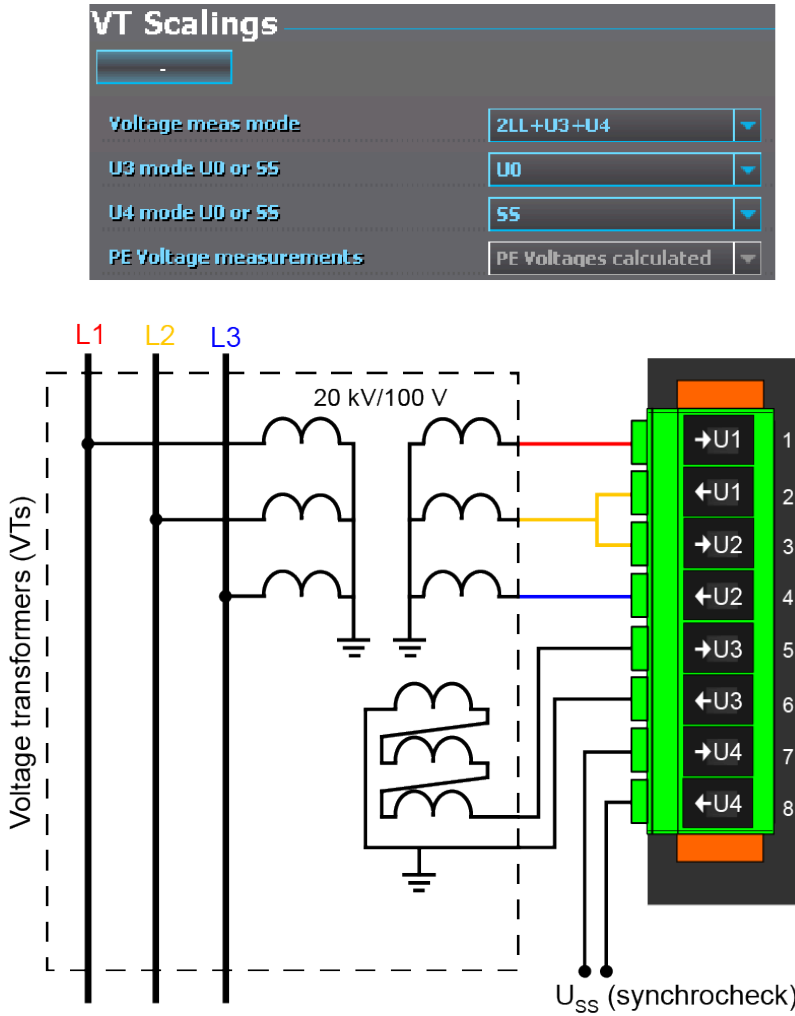

The image collection below presents the device's behavior when nominal voltage is injected into the device via secondary test equipment. The measurement mode is 3LN+U4 which means that the device is measuring line-to-neutral voltages. The VT scaling has been set to 20 000 : 100 V. The U4 channel measures the zero sequence voltage which has the same ratio (20 000 : 100 V).

Figure. 4.2.2 - 13. Measurement behavior when nominal voltage injected.

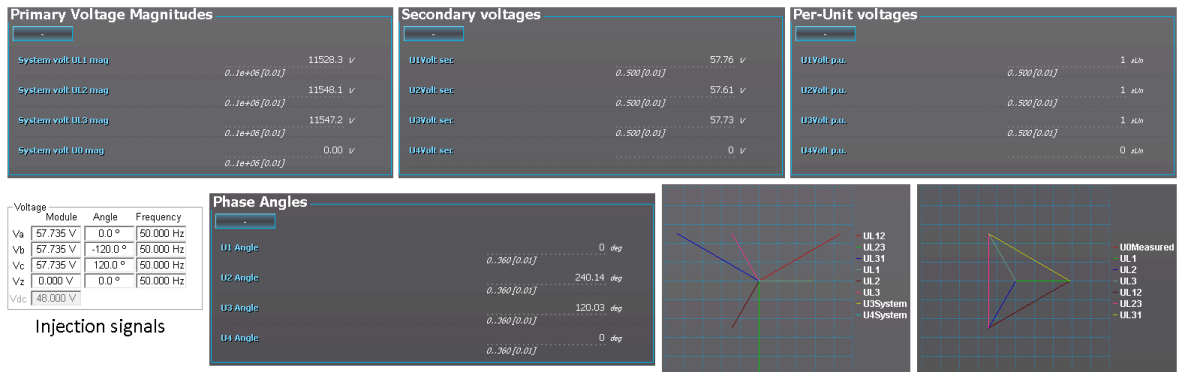

The image collection below presents the device's behavior when voltage is injected into the device via secondary test equipment during an earth fault. The measurement mode is 3LN+U4 which means that the device is measuring line-to-neutral voltages. The VT scaling has been set to 20 000 : 100 V. The U4 channel measures the zero sequence voltage which has the same ratio (20 000 : 100 V).

Figure. 4.2.2 - 14. Device behavior when voltage injected during an earth fault.

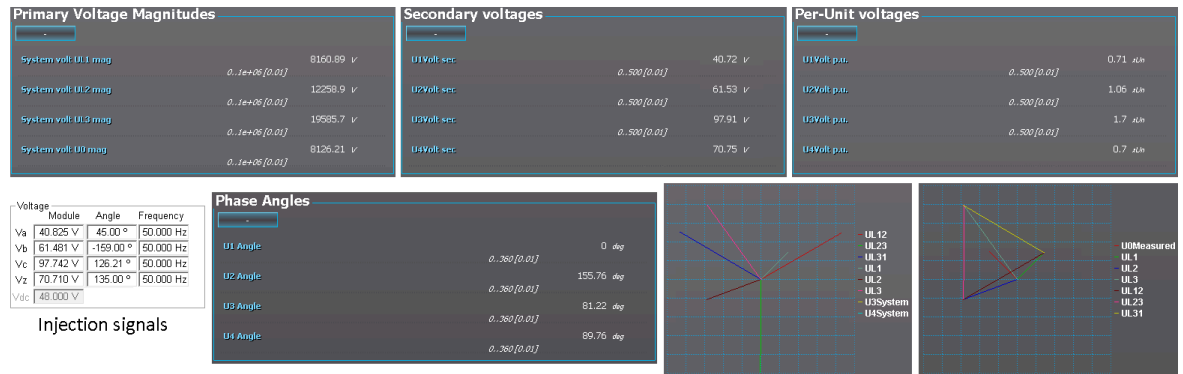

## Troubleshooting

When the measured voltage values differ from the expected voltage values, the following table offers possible solutions for the problems.

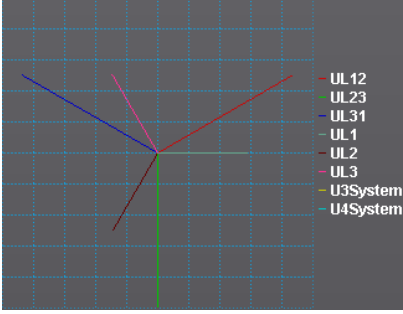
| Problem  | Check / Resolution  |
|--|---|
| The measured voltage amplitude in all phases does not match the injected voltage.  | The scaling settings or the voltage measurement mode may be wrong, check that the settings match with the connected voltage transformer ( <i>Measurement</i> → <i>Transformers</i> → <i>VT Module</i> ).  |
| The measured voltage amplitude does not match one of the measured phases./<br>The calculated U0 is measured even though it should not.   | Check the wiring connections between the injection device or the VTs and the device.  |
| The measured voltage amplitudes are OK but the angles are strange./<br>The voltage unbalance protection trips immediately after activation./<br>The earth fault protection trips immediately after it is activated and voltage calculated. | The voltages are connected to the measurement module but the order or polarity of one or all phases is incorrect. In device settings, go to <i>Measurement</i> → <i>Phasors</i> and check the "System voltage vectors" diagram. When all connections are correct, the diagram (symmetric feeding) should look like this:<br> |

## Alternative Settings

Table. 4.2.2 - 25. Settings of the VT scaling.

| Name                         | Range   | Step                     | Default                  | Description  |
|------------------------------|---|--------------------------|--------------------------|--|
| Voltage measurement mode     | <ul style="list-style-type: none"> <li>3LN+U4</li> <li>3LL+U4</li> <li>2LL+U3+U4</li> </ul>               | -                        | 3LN+U4                   | The device's voltage wiring method. The voltages are scaled according the set voltage measurement mode.  |
| U3 mode U0 or SS             | <ul style="list-style-type: none"> <li>Not Used</li> <li>U0</li> <li>SS</li> </ul>                        | -                        | Not Used                 | The voltage channel U3 can be used to measure zero sequence voltage (U0) or the Synchrocheck voltage (SS). If neither is needed, the (default) option "Not Used" should be active. This setting is only valid if the "2LL+U3+U4" mode is selected.   |
| U4 mode U0 or SS             |   |                          |                          | The voltage channel U4 can be used to measure zero sequence voltage (U0) or the Synchrocheck voltage (SS). If neither is needed, the (default) option "Not Used" should be active.   |
| U0 (U3) Measured from        | <ul style="list-style-type: none"> <li>Broken Delta</li> <li>Neutral point</li> <li>Open delta</li> </ul> | -                        | Broken delta             | Defines how the secondary voltage is scaled to the primary. "Broken Delta" is the most common mode. Does not affect how protection operates, it only affects the displayed primary voltages. This parameter is visible when the "U4 mode U0 or SS" has been set to the "U0" mode. Example with scaling 20000/100 for U <sub>0</sub> and injection 10V secondary: <ul style="list-style-type: none"> <li>Broken delta: 1155V (10%)</li> <li>Neutral point: 2000 V (17.34%)</li> <li>Open delta: 667V (5.78%)</li> </ul> |
| U0 (U4) Measured from        |   |                          |                          | Defines how the secondary voltage is scaled to the primary. "Broken Delta" is the most common mode. Does not affect how protection operates, it only affects the displayed primary voltages. This parameter is visible when the "U4 mode U0 or SS" has been set to the "U0" mode. Example with scaling 20000/100 for U <sub>0</sub> and injection 10V secondary: <ul style="list-style-type: none"> <li>Broken delta: 1155V (10%)</li> <li>Neutral point: 2000 V (17.34%)</li> <li>Open delta: 667V (5.78%)</li> </ul> |
| Set input voltage thresholds | <ul style="list-style-type: none"> <li>No</li> <li>Yes</li> </ul>   | -                        | Yes                      | If this parameter is enabled, it is possible to set minimum voltage required for voltage measurement to start.   |
| U1 input threshold           | 0.10...50.00<br>V <sub>sec</sub>  | 0.01<br>V <sub>sec</sub> | 1.00<br>V <sub>sec</sub> | Sets the lowest voltage the channel is allowed to measure.   |
| U2 input threshold           |   |                          |                          |  |
| U3 input threshold           |   |                          |                          |  |
| U4 input threshold           |   |                          |                          |  |

| Name                     | Range   | Step | Default   | Description   |
|--------------------------|---|------|-----------|---|
| Voltage memory           | <ul style="list-style-type: none"> <li>Disabled</li> <li>Activated</li> </ul>   | -    | Disabled  | Activates the voltage memory. The "Voltage memory" chapter describes the function in more detail.   |
| P-E Voltage measurements | <ul style="list-style-type: none"> <li>No P-E voltages available</li> <li>P-E Voltages calculated</li> <li>P-E Voltages measured</li> </ul> | -    | -         | Indicates whether or not phase-to-earth voltages are available. Also indicates whether P-E voltages are measured from the voltage channels directly or if they are calculated from measured line-to-line and zero sequence voltages.            |
| VT primary               | 1.0...1 000 000.0V  | 0.1V | 20 000.0V | The rated primary voltage of the voltage transformer.   |
| VT secondary             | 0.2...400.0V  | 0.1V | 100.0V    | The rated secondary voltage of the voltage transformer.   |
| U3 Res/SS VT primary     | 1.0...1 000 000V  | 0.1V | 20 000.0V | The primary nominal voltage of the connected U0 or SS VT. This setting is only valid if the "2LL+U3+U4" mode is selected.   |
| U3 Res/SS VT secondary   | 0.2...400.0V  | 0.1V | 100.0V    | The secondary nominal voltage of the connected U0 or SS VT. This setting is only valid if the "2LL+U3+U4" mode is selected.   |
| U4 Res/SS VT primary     | 1.0...1 000 000.0V  | 0.1V | 20 000.0V | The primary nominal voltage of the connected U0 or SS VT.   |
| U4 Res/SS VT secondary   | 0.2...400.0V  | 0.1V | 100.0V    | The secondary nominal voltage of the connected U0 or SS VT.   |
| U1 Polarity              | <ul style="list-style-type: none"> <li>-</li> <li>Invert</li> </ul>   | -    | -         | The selection of the first voltage measurement channel's (U1) polarity (direction). The default setting is for the positive voltage to flow from connector 1 to connector 2, with the secondary voltage's starpoint pointing towards the line.  |
| U2 Polarity              |   |      |           | The selection of the second voltage measurement channel's (U2) polarity (direction). The default setting is for the positive voltage to flow from connector 3 to connector 4, with the secondary voltage's starpoint pointing towards the line. |
| U3 Polarity              |   |      |           | The selection of the third voltage measurement channel's (U3) polarity (direction). The default setting is for the positive voltage to flow from connector 5 to connector 6, with the secondary voltage's starpoint pointing towards the line.  |
| U4 Polarity              |   |      |           | The selection of the fourth voltage measurement channel's (U4) polarity (direction). The default setting is for the positive voltage to flow from connector 7 to connector 8, with the secondary voltage's starpoint pointing towards the line. |

Table. 4.2.2 - 26. Read-only parameters of the VT scaling.

| Name                           | Description   |
|--------------------------------|---|
| VT scaling factor P/S          | The calculated scaling factor that is the ratio between the primary voltage and the secondary voltage.  |
| VT scaling factor p.u. Pri     | The scaling factor for the primary voltage's per-unit value.  |
| VT scaling factor p.u. Sec     | The scaling factor for the secondary voltage's per-unit value.  |
| U3 VT scaling factor P/S U0/SS | The scaling factor that is the ratio between the U3 channel's primary and secondary voltages. This setting is only valid if the "2LL+U3+U4" mode is selected. |
| U3 scaling factor p.u. Pri     | Scaling factor for the primary voltage's per-unit value. This setting is only valid if the "2LL+U3+U4" mode is selected.                                      |
| U3 scaling factor p.u. Sec     | Scaling factor for the secondary voltage's per-unit value. This setting is only valid if the "2LL+U3+U4" mode is selected.                                    |
| U4 VT scaling factor P/S U0/SS | Scaling factor that is the ration between the U4 channel's primary and secondary voltages. This setting is only valid is the "2LL+U3+U4" mode is selected.    |
| U4 scaling factor p.u. Pri     | Scaling factor for the primary voltage's per-unit value. This setting is only valid if the "2LL+U3+U4" mode is selected.                                      |
| U4 scaling factor p.u. Sec     | Scaling factor for the secondary voltage's per-unit value. This setting is only valid if the "2LL+U3+U4" mode is selected.                                    |

## Measurements

The following measurements are available in the measured voltage channels.

Table. 4.2.2 - 27. Per-unit voltage measurements.

| Name             | Range                        | Step                | Description  |
|------------------|------------------------------|---------------------|--|
| UxVolt p.u.      | 0.00...500.00xU <sub>N</sub> | 0.01xU <sub>N</sub> | The voltage measurement fundamental frequency component (in p.u.) from each of the voltage channels.               |
| UxVolt TRMS p.u. | 0.00...500.00xU <sub>N</sub> | 0.01xU <sub>N</sub> | The TRMS voltage (inc. harmonics up to 31 <sup>st</sup> ) measurement (in p.u.) from each of the voltage channels. |

Table. 4.2.2 - 28. Secondary voltage measurements.

| Name            | Range          | Step  | Description  |
|-----------------|----------------|-------|--|
| Ux Volt sec     | 0.00...500.00V | 0.01V | The secondary voltage measurement fundamental frequency component from each of the voltage channels.               |
| UxVolt TRMS sec | 0.00...500.00V | 0.01V | The secondary TRMS voltage (inc. harmonics up to 31 <sup>st</sup> ) measurement from each of the voltage channels. |

Table. 4.2.2 - 29. Voltage phase angle measurements.

| Name     | Range          | Step  | Description   |
|----------|----------------|-------|---|
| Ux Angle | 0.00...360.00° | 0.01° | The phase angle measurement from each of the four voltage inputs. |

Table. 4.2.2 - 30. Per-unit sequence voltage measurements.

| Name               | Range                        | Step                | Description  |
|--------------------|------------------------------|---------------------|--|
| Pos.seq.Volt.p.u.  | 0.00...500.00xU <sub>N</sub> | 0.01xU <sub>N</sub> | The measurement (in p.u.) from the calculated positive sequence voltage. |
| Neg.seq.Volt.p.u.  | 0.00...500.00xU <sub>N</sub> | 0.01xU <sub>N</sub> | The measurement (in p.u.) from the calculated negative sequence voltage. |
| Zero.seq.Volt.p.u. | 0.00...500.00xU <sub>N</sub> | 0.01xU <sub>N</sub> | The measurement (in p.u.) from the calculated zero sequence voltage.     |

Table. 4.2.2 - 31. Primary sequence voltage measurements.

| Name              | Range                | Step  | Description  |
|-------------------|----------------------|-------|--|
| Pos.seq.Volt.pri  | 0.00...1 000 000.00V | 0.01V | The primary measurement from the calculated positive sequence voltage. |
| Neg.seq.Volt.pri  | 0.00...1 000 000.00V | 0.01V | The primary measurement from the calculated negative sequence voltage. |
| Zero.seq.Volt.pri | 0.00...1 000 000.00V | 0.01V | The primary measurement from the calculated zero sequence voltage.     |

Table. 4.2.2 - 32. Secondary sequence voltage measurements.

| Name              | Range            | Step  | Description  |
|-------------------|------------------|-------|--|
| Pos.seq.Volt.sec  | 0.00...4 800.00V | 0.01V | The secondary measurement from the calculated positive sequence voltage. |
| Neg.seq.Volt.sec  | 0.00...4 800.00V | 0.01V | The secondary measurement from the calculated negative sequence voltage. |
| Zero.seq.Volt.sec | 0.00...4 800.00V | 0.01V | The secondary measurement from the calculated zero sequence voltage.     |

Table. 4.2.2 - 33. Sequence voltage angle measurements.

| Name                | Range          | Step  | Description                                     |
|---------------------|----------------|-------|---|
| Pos.seq.Volt.Angle  | 0.00...360.00° | 0.01° | The calculated positive sequence voltage angle. |
| Neg.seq.Volt.Angle  | 0.00...360.00° | 0.01° | The calculated negative sequence voltage angle. |
| Zero.seq.Volt.Angle | 0.00...360.00° | 0.01° | The calculated zero sequence voltage angle.     |

Table. 4.2.2 - 34. System primary voltage measurements.

| Name                 | Range                      | Step  | Description  |
|----------------------|----------------------------|-------|--|
| System volt UL12 mag | 0.00...1<br>000<br>000.00V | 0.01V | The primary line-to-line UL12 voltage fundamental frequency component (measured or calculated). You can also select the row where the unit for this is kV.   |
| System volt UL23 mag | 0.00...1<br>000<br>000.00V | 0.01V | The primary line-to-line UL23 voltage fundamental frequency component (measured or calculated). You can also select the row where the unit for this is kV.   |
| System volt UL31 mag | 0.00...1<br>000<br>000.00V | 0.01V | The primary line-to-line UL31 voltage fundamental frequency component (measured or calculated). You can also select the row where the unit for this is kV.   |
| System volt UL1 mag  | 0.00...1<br>000<br>000.00V | 0.01V | The primary line-to-neutral UL1 voltage fundamental frequency component (measured or calculated). You can also select the row where the unit for this is kV.   |
| System volt UL2 mag  | 0.00...1<br>000<br>000.00V | 0.01V | The primary line-to-neutral UL2 voltage fundamental frequency component (measured or calculated). You can also select the row where the unit for this is kV.   |
| System volt UL3 mag  | 0.00...1<br>000<br>000.00V | 0.01V | The primary line-to-neutral UL3 voltage fundamental frequency component (measured or calculated). You can also select the row where the unit for this is kV.   |
| System volt U0 mag   | 0.00...1<br>000<br>000.00V | 0.01V | The primary zero sequence U0 voltage fundamental frequency component (measured or calculated). You can also select the row where the unit for this is kV. There is also a row where the unit is %.   |
| System volt U3 mag   | 0.00...1<br>000<br>000.00V | 0.01V | The primary measured Synchrocheck voltage fundamental frequency component (SS). This magnitude is displayed only when the "2LL+U3+U4" mode is selected and both U3 and U4 are in use. You can also select the row where the unit for this is kV. |
| System volt U4 mag   | 0.00...1<br>000<br>000.00V | 0.01V | The primary measured Synchrocheck voltage fundamental frequency component (SS). This magnitude is displayed only when the "2LL+U3+U4" mode is selected and both U3 and U4 are in use. You can also select the row where the unit for this is kV. |

Table. 4.2.2 - 35. Primary system voltage angles.

| Name                 | Range          | Step  | Description   |
|----------------------|----------------|-------|---|
| System volt UL12 ang | 0.00...360.00° | 0.01° | The primary line-to-line angle UL12 (measured or calculated). |
| System volt UL23 ang | 0.00...360.00° | 0.01° | The primary line-to-line angle UL23 (measured or calculated). |

| Name                 | Range          | Step  | Description   |
|----------------------|----------------|-------|---|
| System volt UL31 ang | 0.00...360.00° | 0.01° | The primary line-to-line angle UL23 (measured or calculated).   |
| System volt UL1 ang  | 0.00...360.00° | 0.01° | The primary line-to-neutral angle UL1 (measured or calculated).   |
| System volt UL2 ang  | 0.00...360.00° | 0.01° | The primary line-to-neutral angle UL2 (measured or calculated).   |
| System volt UL3 ang  | 0.00...360.00° | 0.01° | The primary line-to-neutral angle UL3 (measured or calculated).   |
| System volt U0 ang   | 0.00...360.00° | 0.01° | The primary zero sequence angle U0 (measured or calculated).  |
| System volt U3 ang   | 0.00...360.00° | 0.01° | The primary measured Synchrocheck angle SS. This magnitude is only valid when the "2LL+U3+U4" mode is selected and both U3 and U4 are in use.     |
| System volt U4 ang   | 0.00...360.00° | 0.01° | The primary measured Synchrocheck angle SS. This magnitude is displayed only when the "2LL+U3+U4" mode is selected and both U3 and U4 are in use. |

Table. 4.2.2 - 36. Harmonic voltage measurements.

| Name  | Range  | Step   | Description   |
|---|--|--------|---|
| Harm Abs.or Perc.   | <ul style="list-style-type: none"> <li>Percent</li> <li>Absolute</li> </ul>                        | -      | Defines whether the harmonics are calculated as percentages or absolute values.                                     |
| Harmonics display   | <ul style="list-style-type: none"> <li>Per unit</li> <li>Primary V</li> <li>Secondary V</li> </ul> | -      | Defines how the harmonics are displayed: in p.u. values, as primary voltage values, or as secondary voltage values. |
| UxMaxH  | 0.00...100<br>000.00V  | 0.01V  | Displays the maximum harmonics value of the selected voltage input Ux.  |
| Ux Fund   | 0.00...100<br>000.00V  | 0.01V  | Displays the voltage value of the fundamental frequency component of the selected voltage input Ux.                 |
| Ux harmonics (2 <sup>nd</sup> ...31 <sup>st</sup> harmonic) | 0.00...100<br>000.00V  | 0.01V  | Displays the selected harmonic from the voltage input Ux.   |
| Ux Amplitude THD  | 0.000...100.000V   | 0.001V | Amplitude ratio THD voltage. Recognized by IEC.   |
| Ux Power THD  | 0.000...100.000V   | 0.001V | Power ratio THD voltage. Recognized by the IEEE.  |

## Voltage memory

Some protection functions (such as directional overcurrent) use the device's measured current and voltage to determine whether the electrical network fault appears to be inside the protected area. The determination is made by comparing the angle between the operating quantity (zone/tripping area) and the actual measured quantity. The function then produces an output when the required terms are met.

In close-in faults the system voltage on the secondary side may fall down to a few volts or close to nothing. In such cases, when the measured voltage is absent, the fault direction cannot be solved. As a backup, non-directional protection can be used for tripping, but in such cases the selectivity of the network will be reduced. However, an angle memory for voltage can be used to prevent this from happening. An adjustable voltage level with pre-fault voltage angles can be used as a reference for fault direction and/or distance. The reference can be set manually for duration. Configurable voltage memory enables even time-delayed backup tripping to be initiated.

The user can activate voltage memory (and find all related settings) by following this path in device settings: *Measurement* → *Transformers* → *VT Module (3U/4U) 1* → *Voltage memory* ("Activated"/"Disabled").

The activation of voltage memory depends of following criteria:

1. Normal voltage levels have been present for longer than 2.5 seconds before voltages have dropped.
2. All used line-to-line or line-to-neutral voltages need to be below the set value for the "VMEM activation voltage" parameter.
3. At least one phase current must be above the set value for the "Measured current condition 3I>" parameter. This setting limit is optional.

Figure. 4.2.2 - 15. Directional overcurrent characteristics.

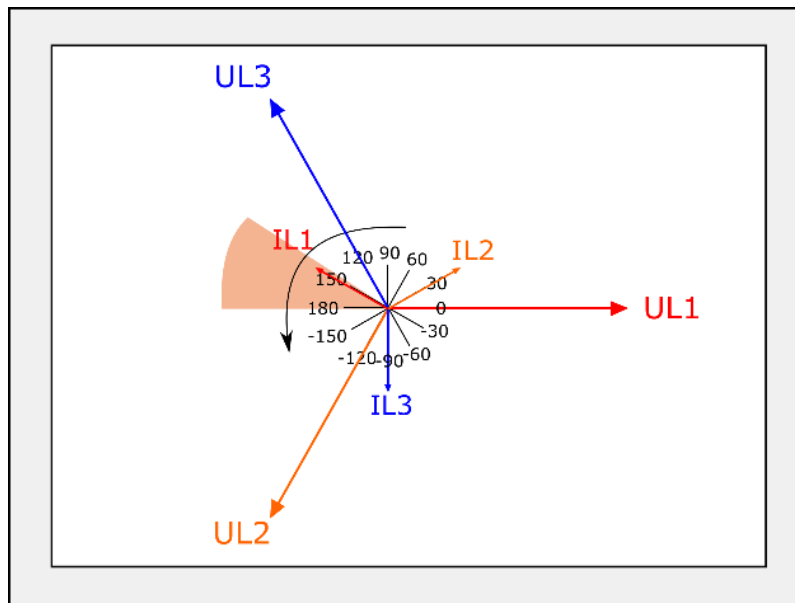

Voltage memory activates when the above-mentioned criteria are met. Voltage memory uses the "VMEM activation voltage" parameter as voltage amplitude even when the actual measured voltage has decreased below it or close to zero. The angle used by this function is the one captured the moment before the fault occurred and voltage memory was activated. When voltage memory is activated, the output "Voltage memory on" signal is activated. This signal can be found in the device's I/O matrix.

While voltage memory is active, voltages are absent and therefore angle measurement is not possible. Healthy state angles (before a fault) are used during a fault. This is why a drift between the assumed voltage angle and the actual measured phase current angle takes place. While voltage memory is used, the angle of phase currents drifts approximately one degree for each passing second (see the graph below).

Figure. 4.2.2 - 16. Voltage angle drift.

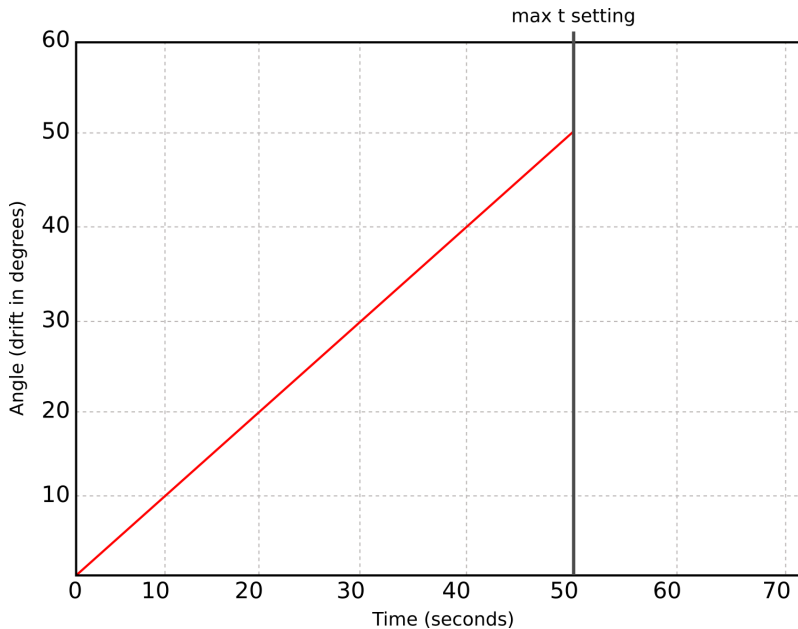

The blocking signal for voltage memory can be found among other stage-related settings in the tab *VT Module (3U/4U) 1*. The blocking signal is checked in the beginning of each program cycle.

#### VMEM activation voltage and Measured current condition 3I>

When the voltage memory function is enabled, it activates when all line voltages drop below the "VMEM activation voltage" threshold limit. When "Measured current condition 3I>" is used, activation cannot be based on just the voltage. Therefore, at least one of the three-phase currents must also rise above the set current pick-up setting.

#### VMEM max active time

Voltage memory can be active for a specific period of time, set in "VMAX active time". It can be anything between 0.02...50.00 seconds. The function supports the definite time (DT) delay type. It depends on the application for how long the memory should be used. During massive bolted faults, the fault should be cleared and the breaker opened as soon as possible; therefore, a short operating time for voltage memory is usually applied. A typical delay for voltage memory is between 0.5...1.0 s. When the operating time passes and voltage memory is no longer used, the protection function operation is blocked and possible START or TRIP signals are reset. The memory uses longer operating times when a backup protection is applied.

#### Forced CT f tracking on VMEM

While fixed frequency tracking is used, all protection stage-based sampling (apart from frequency protection) is based on a set fixed frequency such as 50 Hz or 60 Hz. When the frequency drops massively during a fault while angle memory is in use, it is also possible that the frequency of the system starts to fluctuate. In such cases, if current sampling of used protection stages is based on 50/60 Hz, there could be an error in current magnitude and in angle measurement. To minimize these errors, it is recommended that the frequency is measured and protection-based sampling from the current is performed while voltages are gone.

When the "Forced CT f tracking" parameter is activated and voltages are gone, the frequency from the selected current-based reference channel 3 (the current from IL3) is used for current sampling. This eliminates any possible measurement errors in the fixed frequency mode.

For example, let us say a 500 A current is measured on the primary side while the fixed frequency is set to 50 Hz. This results in the frequency dropping to 46 Hz, while the actual current measurement would be 460 A. Therefore, the system would have an error of 40 A.

Table. 4.2.2 - 37. Voltage memory parameters.

| Name                                | Range   | Step     | Default   | Description  |
|-------------------------------------|---|----------|-----------|--|
| Voltage memory                      | <ul style="list-style-type: none"> <li>Disabled</li> <li>Activated</li> </ul> | -        | Enabled   | Enables or activates voltage memory function.  |
| VMEM activation voltage             | 0.10...50.00 %Un  | 0.01 %Un | 15.00 %Un | Voltage threshold for activating voltage memory. When all voltage measurements are under this setting value, voltage memory is activated.                            |
| VMEM max active time                | 0.020...50.000 s  | 0.005 s  | 15.000 s  | Maximum duration for voltage memory. After the time set in this parameter has passed, voltage memory is reset.   |
| Enable forced CT f tracking on VMEM | <ul style="list-style-type: none"> <li>Disabled</li> <li>Activated</li> </ul> | -        | Disabled  | When in use, frequency tracking is forced to "reference 3" when no voltage can be measured. If this parameter is used, frequency reference 3 should be set to "IL3". |
| Forced CT tracking status           | <ul style="list-style-type: none"> <li>Disabled</li> <li>Activated</li> </ul> | -        | -         | Displays the current status of the "forced CT tracking".   |
| Measured current condition 3I>      | <ul style="list-style-type: none"> <li>Disabled</li> <li>Activated</li> </ul> | -        | Disabled  | Enables or activates current condition monitoring. When in use, at least one of the phase currents must rise above a set value for the voltage memory to activate.   |
| Minimum current for VMEM            | 0.01...50.00 xIn  | 0.01 xIn | 1.00 xIn  | Minimum required current for current condition.  |
| Current condition status            | <ul style="list-style-type: none"> <li>Disabled</li> <li>Activated</li> </ul> | -        | -         | Displays the current monitoring status.  |

Table. 4.2.2 - 38. Voltage memory event messages.

| Event block name | Event names                      |
|------------------|----------------------------------|
| M1VT1            | Voltage memory enabled/disabled  |
| M1VT1            | Voltage low detected ON/OFF      |
| M1VT1            | Current high detected ON/OFF     |
| M1VT1            | Frequency tracked from CT ON/OFF |
| M1VT1            | Using Voltage memory ON/OFF      |
| M1VT1            | Voltage memory blocked ON/OFF    |

### 4.2.3 Power and energy calculation

Power is divided into three magnitudes: apparent power (S), active power (P) and reactive power (Q). Energy measurement calculates magnitudes for active and reactive energy. Energy can flow to the forward direction (exported) or to the reverse direction (imported).

If a unit has more than one CT measurement module, the user can choose which module's current measurement is used by the power calculation. The power and energy measurements are updated every 5 milliseconds.

#### Line-to-neutral voltages available

Power is calculated from line-to-neutral voltages and phase currents. If line-to-line voltages are connected, the device can calculate line-to-neutral voltages based on the measured zero sequence voltage. The following equations apply for power calculations with the line-to-neutral mode and the line-to-line voltage mode (with U0 connected and measured):

Figure. 4.2.3 - 17. Three-phase power (S) calculation.

$$S_{L1} = U_{L1} \times I_{L1}$$

$$S_{L2} = U_{L2} \times I_{L2}$$

$$S_{L3} = U_{L3} \times I_{L3}$$

$$S = S_{L1} + S_{L2} + S_{L3}$$

Figure. 4.2.3 - 18. Three-phase active power (P) calculation.

$$P_{L1} = U_{L1} \times I_{L1} \cos \varphi$$

$$P_{L2} = U_{L2} \times I_{L2} \cos \varphi$$

$$P_{L3} = U_{L3} \times I_{L3} \cos \varphi$$

$$P = P_{L1} + P_{L2} + P_{L3}$$

In these equations, phi ( $\varphi$ ) is the angle difference between voltage and current.

Figure. 4.2.3 - 19. Three-phase reactive power (Q) calculation.

$$Q_{L1} = U_{L1} \times I_{L1} \sin \varphi$$

$$Q_{L2} = U_{L2} \times I_{L2} \sin \varphi$$

$$Q_{L3} = U_{L3} \times I_{L3} \sin \varphi$$

$$Q = Q_{L1} + Q_{L2} + Q_{L3}$$

Active power can be to the forward or the reverse direction. The direction of active power can be indicated with the power factor (Cos ( $\varphi$ ), or Cosine phi), which is calculated according the following formula:

$$3PH \cos(\phi) = P/S$$

$$L1 \cos(\phi) = P_{L1}/S_{L1}$$

$$L2 \cos(\phi) = P_{L2}/S_{L2}$$

$$L3 \cos(\phi) = P_{L3}/S_{L3}$$

The direction of reactive power is divided into four quadrants. Reactive power may be inductive or capacitive on both forward and reverse directions. Reactive power quadrant can be indicated with Tan (φ) (tangent phi), which is calculated according the following formula:

$$3PH \tan(\phi) = Q/P$$

$$L1 \tan(\phi) = Q_{L1}/P_{L1}$$

$$L2 \tan(\phi) = Q_{L2}/P_{L2}$$

$$L3 \tan(\phi) = Q_{L3}/P_{L3}$$

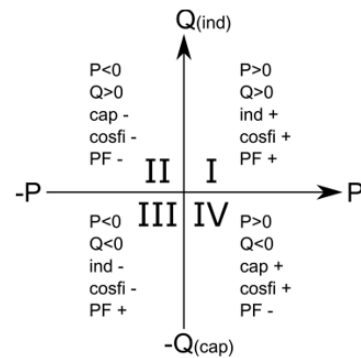

Power factor calculation is done similarly to the Cosine phi calculation but the polarity is defined by the reactive power direction. Therefore, the power factor is calculated with the following formula:

$$3PH PF = P/S * Q/|Q|$$

$$L1 PF = P_{L1}/S_{L1} * Q_{L1}/|Q_{L1}|$$

$$L2 PF = P_{L2}/S_{L2} * Q_{L2}/|Q_{L2}|$$

$$L3 PF = P_{L3}/S_{L3} * Q_{L3}/|Q_{L3}|$$

#### Only line-to-line voltages available

If the line-to-line voltages are measured but the zero sequence voltage is not measured or is not otherwise known, the three-phase power calculation is based on Aron's theorem:

$$S = U_{23} \times I_{L1} \cos(30) + U_{31} \times I_{L2} \cos(30)$$

$$P = U_{23} \times I_{L1} \cos(30 - \phi) + U_{31} \times I_{L2} \cos(30 + \phi)$$

$$Q = U_{23} \times I_{L1} \sin(30 - \phi) + U_{31} \times I_{L2} \sin(30 + \phi)$$

Both cos(φ) and tan(φ) are calculated in the same way as in the line-to-neutral mode.

### Troubleshooting

Check the "Troubleshooting" section in chapters "Current measurement and scaling" and "Voltage measurement and scaling" for more information. Most power and energy measurement problems are usually related to the same issues (i.e. wiring errors, wrong measurement modes, faulty frequency settings, etc.).

## Settings

Table. 4.2.3 - 39. Power and energy measurement settings

| Name  | Range   | Step    | Default      | Description  |
|---|---|---------|--------------|--|
| Power measurement currents from                 | <ul style="list-style-type: none"> <li>CT1</li> <li>CT2</li> </ul>  | -       | CT1          | Defines which current transformer module is used in power and energy calculation.  |
| 3ph active energy measurement                   | <ul style="list-style-type: none"> <li>Disabled</li> <li>Enabled</li> </ul>   | -       | Disabled     | Enables/disables the active energy measurement.  |
| 3ph reactive energy measurement                 | <ul style="list-style-type: none"> <li>Disabled</li> <li>Enabled</li> </ul>   | -       | Disabled     | Enables/disables the reactive and apparent energy measurement.   |
| 3ph energy megas or kilos                       | <ul style="list-style-type: none"> <li>Mega</li> <li>Kilo</li> </ul>  | -       | Mega         | Defines whether energy is measured with the prefix 'kilo' ( $10^3$ ) or 'mega' ( $10^6$ ).   |
| Edit energy values                              | <ul style="list-style-type: none"> <li>Disabled</li> <li>Enabled</li> </ul>   | -       | Disabled     | <p>When this parameter is enabled it is possible to manually edit exported and imported active energy values.</p> <div style="border: 1px solid black; padding: 5px;"> <p><b>NOTICE!</b></p> <p> "E 3ph M or k" parameter has to be set to "kilo" for this feature to function.</p> </div> |
| Invert imp/exp energy directions                | <ul style="list-style-type: none"> <li>Not inverted</li> <li>Inverted</li> </ul>  | -       | Not inverted | Inverts the direction of imported and exported energy without affecting the direction of power calculation.  |
| Nominal power kVA                               | 0.10...500000.00kVA   | 0.01kVA | 100kVA       | Defines the nominal power of the protected object.   |
| PQ Quadrant                                     | <ul style="list-style-type: none"> <li>Undefined</li> <li>Q1 Fwd Ind</li> <li>Q2 Rev Cap</li> <li>Q3 Rev Ind</li> <li>Q4 Fwd Cap</li> </ul>             | -       | Undefined    | Indicates what the power PQ quadrant is at that moment.  |
| VA Quadrant                                     | <ul style="list-style-type: none"> <li>Undefined</li> <li>Q1 Fwd Cap AV</li> <li>Q2 Rev Ind AV</li> <li>Q3 Rev Cap VA</li> <li>Q4 Fwd Ind VA</li> </ul> | -       | Undefined    | Indicates what the power VA quadrant is at that moment.  |
| Reset energy calculators ("Reset 3ph Energies") | <ul style="list-style-type: none"> <li>-</li> <li>Reset</li> </ul>  | -       | -            | Resets the memory of the three-phase energy calculators. Goes automatically back to the "-" state after the reset is finished.   |
| Phase active energy measurement                 | <ul style="list-style-type: none"> <li>Disabled</li> <li>Enabled</li> </ul>   | -       | Disabled     | Enables/disables the active energy per phase measurement.  |

| Name   | Range   | Step | Default  | Description  |
|--|---|------|----------|--|
| Phase reactive energy measurement                          | <ul style="list-style-type: none"> <li>Disabled</li> <li>Enabled</li> </ul> | -    | Disabled | Enables/disables the reactive energy per phase measurement.  |
| Phase energies megas or kilos                              | <ul style="list-style-type: none"> <li>Mega</li> <li>Kilo</li> </ul>        | -    | Mega     | Defines whether energy (per phase) is measured with the prefix 'kilo' ( $10^3$ ) or 'mega' ( $10^6$ ).                             |
| Reset energy calculators (per phase) ("Reset E per phase") | <ul style="list-style-type: none"> <li>-</li> <li>Reset</li> </ul>          | -    | -        | Resets the memory of the individual phase energy calculator. Goes automatically back to the "-" state after the reset is finished. |

Table. 4.2.3 - 40. Energy Dose Counter 1 settings

| Name                             | Range  | Step        | Default        | Description  |
|----------------------------------|--|-------------|----------------|--|
| Energy dose counter mode         | <ul style="list-style-type: none"> <li>Disabled</li> <li>Activated</li> </ul>  | -           | Disabled       | Enables/disables energy dose counters generally.   |
| Energy dose counter LN mode      | <ul style="list-style-type: none"> <li>On</li> <li>Blocked</li> <li>Test</li> <li>Test/Blocked</li> <li>Off</li> </ul>   | -           | On             | Set mode of DOS block. This parameter is visible only when <i>Allow setting of individual LN mode</i> is enabled in <i>General</i> menu.                             |
| Energy does counter LN behaviour | <ul style="list-style-type: none"> <li>On</li> <li>Blocked</li> <li>Test</li> <li>Test/Blocked</li> <li>Off</li> </ul>   | -           | -              | Displays the mode of DOS block. This parameter is visible only when <i>Allow setting of individual LN mode</i> is enabled in <i>General</i> menu.                    |
| Clear pulse counter              | <ul style="list-style-type: none"> <li>-</li> <li>Clear</li> </ul>   | -           | -              | Resets the "DC 1...4 Pulses sent" counters back to zero.   |
| DC 1...4 enable                  | <ul style="list-style-type: none"> <li>Disabled</li> <li>Enabled</li> </ul>  | -           | Disabled       | Enables/disables the energy dose counter 1...4 individually.   |
| DC 1...4 Input signal select     | <ul style="list-style-type: none"> <li>3PH.Fwd.Act.EP</li> <li>3PH.Rev.Avt.EP</li> <li>3PH.Fwd.React.EQ.CAP</li> <li>3PH.Fwd.React.EQ.IND</li> <li>3PH.Rev.React.EQ.CAP</li> <li>3PH.Rev.React.EQ.IND</li> </ul> | -           | 3PH.Fwd.Act.EP | Selects whether the energy is active or reactive, whether the direction of the energy is forward or reverse, and whether reactive energy is inductive or capacitive. |
| DC 1...4 Input signal            | $-1 \times 10^6 \dots 1 \times 10^6$   | 0.01        | -              | The total amount of energy consumed.   |
| DC 1...4 Pulse magnitude         | 0...1800kW/var   | 0.005kW/var | 1kW/Var        | The set pulse size. An energy pulse is given every time the set magnitude is exceeded.   |

| Name                  | Range             | Step   | Default | Description                                |
|-----------------------|-------------------|--------|---------|--|
| DC 1...4 Pulse length | 0...1800s         | 0.005s | 1s      | The total length of a control pulse.       |
| DC1...4 Pulses sent   | 0...4 294 967 295 | 1      | -       | Indicates the total number of pulses sent. |

Table. 4.2.3 - 41. DC 1...4 Pulse out settings

| Name               | Range       | Step | Default       | Description                                       |
|--------------------|-------------|------|---------------|---|
| DC 1...4 Pulse out | OUT1...OUTx | -    | None selected | The selection of the controlled physical outputs. |

## Power measurements

The following power calculations are available when the voltage and the current cards are available.

Table. 4.2.3 - 42. Three-phase power calculations.

| Name                       | Range                                     | Step      | Description  |
|----------------------------|---|-----------|--|
| 3PH Apparent power (S)     | $-1 \times 10^6 \dots 1 \times 10^6$ kVA  | 0.001kVA  | The total three-phase apparent power in kilo-volt-ampere |
| 3PH Active power (P)       | $-1 \times 10^6 \dots 1 \times 10^6$ kW   | 0.001kW   | The total three-phase active power in kilowatts          |
| 3PH Reactive power (Q)     | $-1 \times 10^6 \dots 1 \times 10^6$ kVar | 0.001kVar | The total three-phase reactive power in kilovars         |
| 3PH Apparent power (S MVA) | $-1 \times 10^5 \dots 1 \times 10^5$ MVA  | 0.001MVA  | The total three-phase apparent power in megawatts        |
| 3PH Active power (P MW)    | $-1 \times 10^5 \dots 1 \times 10^5$ MW   | 0.001MW   | The total three-phase active power in mewatts            |
| 3PH Reactive power (QMVar) | $-1 \times 10^5 \dots 1 \times 10^5$ MVar | 0.001MVar | The total three-phase active power in megavars           |
| 3PH Tan(phi)               | $-1 \times 10^6 \dots 1 \times 10^6$      | 0.001     | The direction of three-phase active power                |
| 3PH Cos(phi)               | $-1 \times 10^6 \dots 1 \times 10^6$      | 0.001     | The direction of three-phase reactive power              |
| 3PH Power factor           | $-1 \times 10^6 \dots 1 \times 10^6$      | 0.0001    | The three-phase power factor                             |

Table. 4.2.3 - 43. Single-phase power calculations (L1...L3).

| Name                  | Unit | Range                                | Step  | Description   |
|-----------------------|------|--------------------------------------|-------|---|
| Lx Apparent power (S) | kVA  | $-1 \times 10^6 \dots 1 \times 10^6$ | 0.001 | The apparent power of Phase Lx in kilo-volt-amperes |
| Lx Active power (P)   | kW   | $-1 \times 10^6 \dots 1 \times 10^6$ | 0.001 | The active power of Phase Lx in kilowatts           |
| Lx Reactive power (Q) | kVar | $-1 \times 10^6 \dots 1 \times 10^6$ | 0.001 | The reactive power of Phase Lx kilovars             |

| Name            | Unit | Range                                   | Step   | Description                                |
|-----------------|------|---|--------|--|
| Lx Tan(phi)     | -    | -1x10 <sup>6</sup> ...1x10 <sup>6</sup> | 0.001  | The direction of Phase Lx's active power   |
| Lx Cos(phi)     | -    | -1x10 <sup>6</sup> ...1x10 <sup>6</sup> | 0.001  | The direction of Phase Lx's reactive power |
| Lx Power factor | -    | -1x10 <sup>6</sup> ...1x10 <sup>6</sup> | 0.0001 | The power factor of Phase Lx               |

## Energy measurements

The following energy calculations are available when the voltage and the current cards are available. Please note that the unit prefix is determined by the user's selection between 'kilo' and 'mega' in "Three-phase energy prefix ("E 3ph M or k")" under the general "Power and energy measurement settings".

Table. 4.2.3 - 44. Three-phase energy calculations.

| Name  | Range                                   | Step | Description   |
|---|---|------|---|
| Exported Active Energy (P) (kWh or MWh)                       | -1x10 <sup>9</sup> ...1x10 <sup>9</sup> | 1    | The total amount of exported active energy.   |
| Imported Active Energy (P) (kWh or MWh)                       | -1x10 <sup>9</sup> ...1x10 <sup>9</sup> | 1    | The total amount of imported active energy.   |
| Active Energy (P) Export/Import balance (kWh or MWh)          | -1x10 <sup>9</sup> ...1x10 <sup>9</sup> | 1    | The sum of imported and exported active energy.   |
| Exported (Q) while Export (P) (kVarh or MVarh)                | -1x10 <sup>9</sup> ...1x10 <sup>9</sup> | 1    | The total amount of exported reactive energy while active power is exported.                |
| Imported (Q) while Export (P). (kVarh or MVarh)               | -1x10 <sup>9</sup> ...1x10 <sup>9</sup> | 1    | Total amount of imported reactive energy while active energy is exported.                   |
| Reactive energy (Q) balance while export (P) (kVarh or MVarh) | -1x10 <sup>9</sup> ...1x10 <sup>9</sup> | 1    | The sum of imported and exported reactive capacitive energy while active power is exported. |
| Exported (Q) while Import (P) (kVarh or MVarh)                | -1x10 <sup>9</sup> ...1x10 <sup>9</sup> | 1    | The total amount of exported reactive energy while active energy is imported.               |
| Imported (Q) while Import (P) (kVarh or MVarh)                | -1x10 <sup>9</sup> ...1x10 <sup>9</sup> | 1    | The total amount of imported reactive energy while active energy is imported.               |
| Reactive energy (Q) balance while Import (P) (kVarh or MVarh) | -1x10 <sup>9</sup> ...1x10 <sup>9</sup> | 1    | The sum of imported and exported reactive energy while active energy is imported.           |
| Apparent Energy (S) while Export (P) (kVAh or MVAh)           | -1x10 <sup>9</sup> ...1x10 <sup>9</sup> | 1    | The total amount of exported apparent energy while active energy is exported.               |
| Apparent Energy (S) while Import (P) (kVAh or MVAh)           | -1x10 <sup>9</sup> ...1x10 <sup>9</sup> | 1    | The total amount of exported apparent energy while active energy is imported.               |
| Apparent Energy (S) Net                                       | -1x10 <sup>9</sup> ...1x10 <sup>9</sup> | 1    | Total amount of apparent energy.  |
| Real Energy (P) Net   | -1x10 <sup>9</sup> ...1x10 <sup>9</sup> | 1    | The sum of active energy supply and demand.   |
| Reactive Energy (Q) Net                                       | -1x10 <sup>9</sup> ...1x10 <sup>9</sup> | 1    | The sum of reactive energy supply and demand.   |
| Real Energy (P) Supply  | -1x10 <sup>9</sup> ...1x10 <sup>9</sup> | 1    | Total amount of active energy supplied. Default supply direction towards busbar.            |

| Name                       | Range                                | Step | Description   |
|----------------------------|--------------------------------------|------|---|
| Reactive Energy (Q) Supply | $-1 \times 10^9 \dots 1 \times 10^9$ | 1    | Total reactive energy supplied. Default supply direction towards busbar.      |
| Real Energy (P) Demand     | $-1 \times 10^9 \dots 1 \times 10^9$ | 1    | Total amount of active energy demand. Default demand direction from busbar.   |
| Reactive Energy (Q) Demand | $-1 \times 10^9 \dots 1 \times 10^9$ | 1    | Total amount of reactive energy demand. Default demand direction from busbar. |

Table. 4.2.3 - 45. Single-phase energy calculations (L1...L3).

| Name   | Range                                | Step | Description   |
|--|--------------------------------------|------|---|
| Export Active Energy Lx (kWh or MWh)                             | $-1 \times 10^9 \dots 1 \times 10^9$ | 1    | The exported active energy of the phase.  |
| Import Active Energy (kWh or MWh)                                | $-1 \times 10^9 \dots 1 \times 10^9$ | 1    | The imported active energy of the phase.  |
| Active Energy (P) Export/Import balance (kWh or MWh)             | $-1 \times 10^9 \dots 1 \times 10^9$ | 1    | The sum of the phase's imported and exported active energy.                                   |
| Exported (Q) while Export (P) Lx (kVarh or MVarh)                | $-1 \times 10^9 \dots 1 \times 10^9$ | 1    | The exported reactive energy of the phase while active energy is exported.                    |
| Imported (Q) while Export (P) Lx (kVarh or MVarh)                | $-1 \times 10^9 \dots 1 \times 10^9$ | 1    | The imported reactive energy of the phase while active energy is exported.                    |
| Reactive Energy (Q) balance while Export (P) Lx (kVarh or MVarh) | $-1 \times 10^9 \dots 1 \times 10^9$ | 1    | The sum of the phase's imported and exported reactive energy while active energy is exported. |
| Exported (Q) while Import (P) Lx (kVarh or MVarh)                | $-1 \times 10^9 \dots 1 \times 10^9$ | 1    | The exported reactive energy of the phase while active energy is imported.                    |
| Imported (Q) while Import (P) Lx (kVarh or MVarh)                | $-1 \times 10^9 \dots 1 \times 10^9$ | 1    | The imported reactive energy of the phase while active energy is imported.                    |
| Reactive energy (Q) balance while Import (P) Lx (kVarh or MVarh) | $-1 \times 10^9 \dots 1 \times 10^9$ | 1    | The sum of the phase's imported and exported reactive energy while active energy is imported. |
| Apparent Energy (S) while Export (P) Lx                          | $-1 \times 10^9 \dots 1 \times 10^9$ | 1    | The apparent energy of the phase while active energy is exported.                             |
| Apparent Energy (S) while Import (P) Lx                          | $-1 \times 10^9 \dots 1 \times 10^9$ | 1    | The apparent energy of the phase while active energy is imported.                             |

### Calculation examples

Here is an example of power calculation. Both wiring methods (line-to-line and line-to-neutral) are checked with the same signal injection. The voltage scaling is set to 20 000 : 100 V and the current scaling is set to 1000 : 5 A.

| Voltages (line-to-neutral):                | Currents:                               |
|--|---|
| $U_{L1} = 40.825 \text{ V}, 45.00^\circ$   | $I_{L1} = 2.5 \text{ A}, 0.00^\circ$    |
| $U_{L2} = 61.481 \text{ V}, -159.90^\circ$ | $I_{L2} = 2.5 \text{ A}, -120.00^\circ$ |

| Voltages (line-to-neutral):               | Currents:                              |
|---|--|
| $U_{L3} = 97.742 \text{ V}, 126.21^\circ$ | $I_{L3} = 2.5 \text{ A}, 120.00^\circ$ |

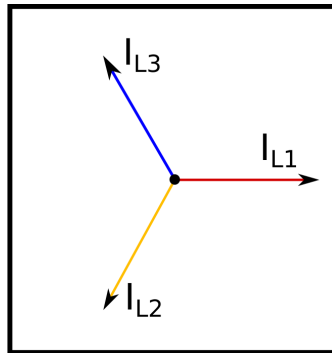
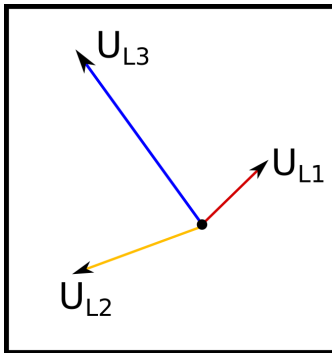

$$S_{L1} = U_{L1} \times I_{L1} = 40.825 \text{ V} \times 2.5 \text{ A} = 102 \text{ VA (secondary)} \quad \mathbf{4.08 \text{ MVA (primary)}}$$

$$P_{L1} = U_{L1} \times I_{L1} \cos \varphi = 40.825 \text{ V} \times 2.5 \text{ A} \cos(45^\circ - 0^\circ) = 72.2 \text{ W (secondary)} \quad \mathbf{2.89 \text{ MW (primary)}}$$

$$Q_{L1} = U_{L1} \times I_{L1} \sin \varphi = 40.825 \text{ V} \times 2.5 \text{ A} \sin(45^\circ - 0^\circ) = 72.2 \text{ var (secondary)} \quad \mathbf{2.89 \text{ MVar (primary)}}$$

$$L1 \tan(\phi) = Q_{L1}/P_{L1} = 2.89/2.89 = \mathbf{1.00}$$

$$L1 \cos(\phi) = P_{L1}/S_{L1} = 2.89/4.08 = \mathbf{0.71}$$

| Name   | Value     | Name   | Value      | Name   | Value     | Name    | Value     |
|--------|-----------|--------|------------|--------|-----------|---------|-----------|
| L1 (S) | 4.08 MVA  | L2 (S) | 6.15 MVA   | L3 (S) | 9.77 MVA  | 3PH (S) | 20.00 MVA |
| L1 (P) | 2.89 MW   | L2 (P) | 4.72 MW    | L3 (P) | 9.71 MW   | 3PH (P) | 17.32 MW  |
| L1 (Q) | 2.89 Mvar | L2 (Q) | -3.94 Mvar | L3 (Q) | 1.06 Mvar | 3PH (Q) | 0.01 Mvar |
| L1 Tan | 1.00      | L2 Tan | -0.83      | L3 Tan | 0.11      | 3PH Tan | 0.00      |
| L1 Cos | 0.71      | L2 Cos | 0.77       | L3 Cos | 0.99      | 3PH Cos | 0.87      |

| Voltages (line-to-line):                   | Currents:                               |
|--|---|
| $U_{L12} = 100.00 \text{ V}, 30.00^\circ$  | $I_{L1} = 2.5 \text{ A}, 0.00^\circ$    |
| $U_{L23} = 100.00 \text{ V}, -90.00^\circ$ | $I_{L2} = 2.5 \text{ A}, -120.00^\circ$ |
|  | $I_{L3} = 2.5 \text{ A}, 120.00^\circ$  |

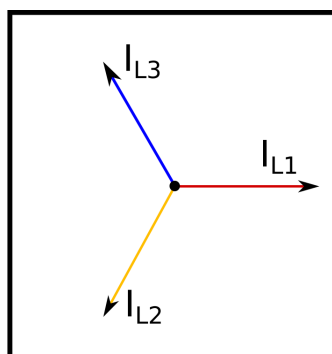
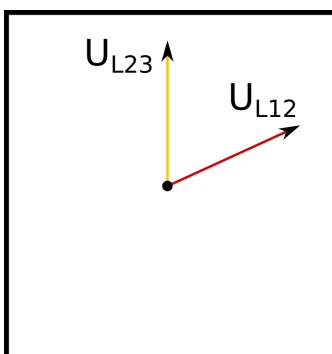

$$S = U_{12} \times I_{L1} + U_{23} \times I_{L2}$$

$$S = 100 \text{ V} \times 2.5 \text{ A} + 100 \text{ V} \times 2.5 \text{ A} = 500 \text{ VA (sec)} \quad \mathbf{20.00 \text{ MVA (pri)}}$$

$$P = U_{12} \times I_{L1} \cos(-\varphi) + U_{23} \times I_{L2} \cos(\varphi)$$

$$P = 100 \text{ V} \times 2.5 \text{ A} \cos(-30^\circ - 0^\circ) + 100 \text{ V} \times 2.5 \text{ A} \cos(270^\circ - 240^\circ) = 433 \text{ W (sec)} \quad \mathbf{17.32 \text{ MW (pri)}}$$

$$Q = U_{12} \times I_{L1} \sin(-\varphi) + U_{23} \times I_{L2} \sin(\varphi)$$

$$Q = 100 \text{ V} \times 2.5 \text{ A} \sin(-30^\circ - 0^\circ) + 100 \text{ V} \times 2.5 \text{ A} \sin(270^\circ - 240^\circ) = 0 \text{ var (sec)} \quad \mathbf{0 \text{ Mvar (pri)}}$$

$$3PH \text{ Tan}(\phi) = Q/P = 0.01/17.32 = \mathbf{0.00}$$

$$3PH \text{ Cos}(\phi) = P/S = 17.32/20.00 = \mathbf{0.87}$$

| Name    | Values    |
|---------|-----------|
| 3PH (S) | 20.00 MVA |
| 3PH (P) | 17.32 MW  |
| 3PH (Q) | 0.00 Mvar |
| 3PH Tan | 0.00      |
| 3PH Cos | 0.87      |

## 4.2.4 Frequency tracking and scaling

Measurement sampling can be set to the frequency tracking mode or to the fixed user-defined frequency sampling mode. The benefit of frequency tracking is that the measurements are within a pre-defined accuracy range even when the fundamental frequency of the power system changes.

Table. 4.2.4 - 46. Frequency tracking effect (FF changes from 6 Hz to 75 Hz).

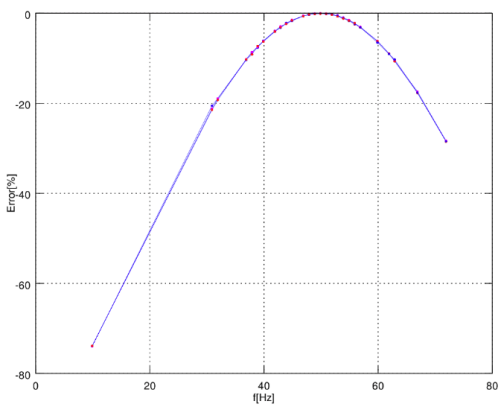
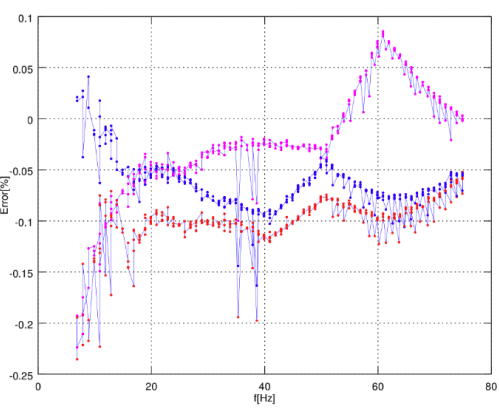
|  |  |
|--|--|
|   |    |
| <p>The measurement error with a fixed 50 Hz sampling frequency when the frequency changes. The constant current is 5 A, the frequency sweep is from 6 Hz to 75 Hz.</p> | <p>The measurement error with frequency tracking when the frequency changes. The constant current is 5 A, the frequency sweep is from 6 Hz to 75 Hz.</p> |

As the figures above show, the sampling frequency has a major effect on the device's measurement accuracy. If the sampling is not tracked to the system frequency, for example a 10 Hz difference between the measured and the set system frequency can give a measurement error of over 5 %. The figures also show that when the frequency is tracked and the sampling is adjusted according to the detected system frequency, the measurement accuracy has an approximate error of 0.1...- 0.2 % error in the whole frequency range.

The device has a measurement accuracy that is independent of the system frequency. This has been achieved by adjusting the sample rate of the measurement channels according to the measured system frequency; this way the FFT calculation always has a whole power cycle in the buffer. The measurement accuracy is further improved by Arcteq's patented calibration algorithms that calibrate the analog channels against eight (8) system frequency points for both magnitude and angle. This frequency-dependent correction compensates the frequency dependencies in the used, non-linear measurement hardware and improves the measurement accuracy significantly. Combined, these two methods give an accurate measurement result that is independent of the system frequency.

## Troubleshooting

When the measured current, voltage or frequency values differ from the expected values, the following table offers possible solutions for the problems.

| Problem  | Check / Resolution  |
|--|---|
| The measured current or voltage amplitude is lower than it should be./<br>The values are "jumping" and are not stable. | The set system frequency may be wrong. Please check that the frequency settings match the local system frequency, or change the measurement mode to "Tracking" ( <i>Measurement</i> → <i>Frequency</i> → "Sampling mode") so the device adjusts the frequency itself. |
| The frequency readings are wrong.  | In Tracking mode the device may interpret the frequency incorrectly if no current is injected into the CT (or voltage into the VT). Please check the frequency measurement settings ( <i>Measurement</i> → <i>Frequency</i> ).  |

## Settings

Table. 4.2.4 - 47. Settings of the frequency tracking.

| Name                      | Range   | Step    | Default | Description   |
|---------------------------|---|---------|---------|---|
| Sampling mode             | <ul style="list-style-type: none"> <li>Fixed</li> <li>Tracking</li> </ul> | -       | Fixed   | Defines which measurement sampling mode is in use: the fixed user-defined frequency, or the tracked system frequency. |
| System nominal frequency  | 7.000...75.000Hz  | 0.001Hz | 50Hz    | The user-defined system nominal frequency that is used when the "Sampling mode" setting has been set to "Fixed".      |
| Tracked system frequency  | 0.000...75.000Hz  | 0.001Hz | -       | Displays the rough measured system frequency.   |
| Sampling frequency in use | 0.000...75.000Hz  | 0.001Hz | -       | Displays the tracking frequency that is in use at that moment.  |

| Name                         | Range   | Step    | Default                    | Description  |
|------------------------------|---|---------|----------------------------|--|
| Frequency reference 1        | <ul style="list-style-type: none"> <li>• None</li> <li>• CT1IL1</li> <li>• CT2IL1</li> <li>• VT1U1</li> <li>• VT2U1</li> </ul>  | -       | CT1IL1                     | The first reference source for frequency tracking.   |
| Frequency reference 2        | <ul style="list-style-type: none"> <li>• None</li> <li>• CT1IL2</li> <li>• CT2IL2</li> <li>• VT1U2</li> <li>• VT2U2</li> </ul>  | -       | CT1IL2                     | The second reference source for frequency tracking.  |
| Frequency reference 3        | <ul style="list-style-type: none"> <li>• None</li> <li>• CT1IL3</li> <li>• CT2IL3</li> <li>• VT1U3</li> <li>• VT2U3</li> </ul>  | -       | CT1IL3                     | The third reference source for frequency tracking.   |
| Frequency tracking quality   | <ul style="list-style-type: none"> <li>• No trackable channels</li> <li>• Reference 1 trackable</li> <li>• Reference 2 trackable</li> <li>• References 1 &amp; 2 trackable</li> <li>• Reference 3 trackable</li> <li>• Reference 1 &amp; 3 trackable</li> <li>• References 2 &amp; 3 trackable</li> <li>• All references trackable</li> </ul> | -       | -                          | Defines the frequency tracker quality. If the measured current (or voltage) amplitude is below the threshold, the channel tracking quality is 0 and cannot be used for frequency tracking. If all channels' magnitudes are below the threshold, there are no trackable channels. |
| Frequency measurement in use | <ul style="list-style-type: none"> <li>• No track ch</li> <li>• Ref1</li> <li>• Ref2</li> <li>• Ref3</li> </ul>   | -       | -                          | Indicates which reference is used at the moment for frequency tracking.  |
| Start behavior               | <ul style="list-style-type: none"> <li>• Start tracking immediately</li> <li>• First nominal or tracked</li> </ul>  | -       | Start tracking immediately | Defines the how the tracking starts. Tracking can start immediately, or there can be a set delay time between the receiving of the first trackable channel and the start of the tracking.  |
| Start sampling with          | <ul style="list-style-type: none"> <li>• Use track frequency</li> <li>• Use nom frequency</li> </ul>  | -       | Use track frequency        | Defines the start of the sampling. Sampling can begin with a previously tracked frequency, or with a user-set nominal frequency.   |
| Use nominal frequency until  | 0...1800.000s   | 0.005s  | 0.100s                     | Defines how long the nominal frequency is used after the tracking has started. This setting is only valid when the "Sampling mode" setting is set to "Tracking" and when the "Start behavior" is set to "First nominal or tracked".  |
| Tracked f channel A          | 0.000...75.000Hz  | 0.001Hz | -                          | Displays the rough value of the tracked frequency in Channel A.  |

| Name                      | Range  | Step    | Default | Description   |
|---------------------------|--|---------|---------|---|
| Tracked f channel B       | 0.000...75.000Hz   | 0.001Hz | -       | Displays the rough value of the tracked frequency in Channel B.   |
| Tracked f channel C       | 0.000...75.000Hz   | 0.001Hz | -       | Displays the rough value of the tracked frequency in Channel C.   |
| System measured frequency | <ul style="list-style-type: none"> <li>• One f measured</li> <li>• Two f measured</li> <li>• Three f measured</li> </ul>   | -       | -       | Displays the amount of frequencies that are measured.   |
| f.atm. Protections        | 0.000...75.000Hz   | 0.001Hz | -       | Frequency measurement value used by protection functions. When frequency is not measurable this value returns to value set to "System nominal frequency" parameter. |
| f.atm. Display            | 0.000...75.000Hz   | 0.001Hz | -       | Frequency measurement value used in display. When frequency is not measurable this value is "0 Hz".   |
| f measurement from        | <ul style="list-style-type: none"> <li>• Not measurable</li> <li>• Avg Ref 1</li> <li>• Avg Ref 2</li> <li>• Avg Ref 3</li> <li>• Track Ref 1</li> <li>• Track Ref 2</li> <li>• Track Ref 3</li> <li>• Fast Ref 1</li> <li>• Fast Ref 2</li> <li>• Fast Ref 3</li> </ul> | -       | -       | Displays which reference is used for frequency measurement.   |
| SS1.meas.frqs             | 0.000...75.000Hz   | 0.001Hz | -       | Displays frequency used by "system set" channel 1 and 2.  |
| SS2.meas.frqs             |  |         |         |   |
| SS1f meas.from            | <ul style="list-style-type: none"> <li>• Not measurable</li> <li>• Fast Ref U3</li> <li>• Fast Ref U4</li> </ul>   | -       | -       | Displays which voltage channel frequency reference is used by "system set" voltage channel.   |
| SS2f meas.from            | <ul style="list-style-type: none"> <li>• Not measurable</li> <li>• Fast Ref U4</li> </ul>  | -       | -       | Displays if U4 channel frequency reference is measurable or not when the channel has been set to "system set" mode.   |

### 4.3 General menu

The *General* menu consists of basic settings and indications of the device. Additionally, the all activated functions and their status are displayed in the *Protection*, *Control* and *Monitor* profiles.

Table. 4.3 - 48. The *General* menu read-only parameters

| Name          | Description  |
|---------------|--|
| Serial number | The unique serial number identification of the unit. |

| Name                                      | Description  |
|---|--|
| Firmware version                          | The firmware software version of the unit.   |
| Hardware configuration                    | The order code identification of the unit.   |
| System phase rotating order at the moment | The selected system phase rotating order. Can be changed with parameter "System phase rotating order". |
| UTC time                                  | The UTC time value which the device's clock uses.  |

Table. 4.3 - 49. Parameters and indications in the *General* menu.

| Name                                | Range  | Default      | Description   |
|-------------------------------------|--|--------------|---|
| Device name                         | -  | Unitname     | The file name uses these fields when loading the .aqs configuration file from the device.   |
| Device location                     | -  | Unitlocation |   |
| Enable stage forcing                | <ul style="list-style-type: none"> <li>Disabled</li> <li>Enabled</li> </ul>  | Disabled     | When this parameter is enabled it is possible for the user to force the protection, control and monitoring functions to different statuses like START and TRIP. This is done in the function's <i>Info</i> page with the <i>Force status to</i> parameter.            |
| Allow setting of device mode        | <ul style="list-style-type: none"> <li>Prohibited</li> <li>From HMI/setting tool only</li> <li>Allowed</li> </ul>  | Prohibited   | Allows global mode to be modified from setting tool, HMI and IEC61850.<br>Prohibited: Cannot be changed.<br>From HMI/setting tool only: Can only be changed from the setting tool or HMI<br>Allowed: Can be changed from the setting tool, HMI, and IEC 61850 client. |
| Allow setting of individual LN mode | <ul style="list-style-type: none"> <li>Prohibited</li> <li>From HMI/setting tool only</li> <li>Allowed</li> </ul>  | Prohibited   | Allow local modes to be modified from setting tool, HMI and IEC61850.<br>Prohibited: Cannot be changed.<br>From HMI/setting tool only: Can only be changed from the setting tool or HMI<br>Allowed: Can be changed from the setting tool, HMI, and IEC 61850 client.  |
| System phase rotating order         | <ul style="list-style-type: none"> <li>A-B-C</li> <li>A-C-B</li> </ul>   | A-B-C        | Allows the user to switch the expected order in which the phase measurements are wired to the unit.   |
| Language                            | <ul style="list-style-type: none"> <li>User defined</li> <li>English</li> <li>Finnish</li> <li>Chinese</li> <li>Spanish</li> <li>French</li> <li>German</li> <li>Russian</li> <li>Ukrainian</li> <li>Kazakh</li> </ul> | English      | Changes the language of the parameter descriptions in the HMI. If the language has been set to "Other" in the settings of the AQtivate setting tool, AQtivate follows the value set into this parameter.  |

| Name                         | Range   | Default     | Description  |
|------------------------------|---|-------------|--|
| AQtivate ethernet port       | <ul style="list-style-type: none"> <li>All</li> <li>COM A</li> <li>Double Ethernet card</li> </ul>  | All         | If the device has a double Ethernet option card it is possible to choose which ports are available for connecting with AQtivate software.  |
| Clear events                 | <ul style="list-style-type: none"> <li>-</li> <li>Clear</li> </ul>  | -           | Clears the event history recorded in the device.   |
| Display brightness           | 0...8   | 4           | Changes the display brightness. Brightness level 0 turns the display off.  |
| Display sleep timeout        | 0...3600s   | 0s          | If no buttons are pressed after a set time, the display changes the brightness to whatever is set on the "Display sleep brightness" parameter. If set to 0 s, this feature is not in use. When the device is in sleep mode, all button actions are disabled. Pressing any of the buttons on the front panel will wake up the display, which enables the buttons again. |
| Display sleep brightness     | 0...8   | 0           | Defines the brightness of the display when the set display sleep timeout has elapsed. The brightness level "0" turns the display off.  |
| Return to default view       | 0...3600s   | 0s          | If the user navigates to a menu and gives no input after a period of time defined with this parameter, the unit automatically returns to the default view. If set to 0 s, this feature is not in use.  |
| LED test                     | <ul style="list-style-type: none"> <li>-</li> <li>Activated</li> </ul>  | -           | When activated, all LEDs are lit up. LEDs with multiple possible colors blink each color.  |
| HMI restart                  | <ul style="list-style-type: none"> <li>-</li> <li>Restart</li> </ul>  | -           | When activated, display restarts.  |
| Display color theme          | <ul style="list-style-type: none"> <li>Light theme</li> <li>Dark theme</li> </ul>   | Light theme | Defines the color theme used in the HMI.   |
| Reset latches                | <ul style="list-style-type: none"> <li>-</li> <li>Reset</li> </ul>  | -           | Resets the latched signals in the logic and the matrix. When a reset command is given, the parameter automatically returns back to "-".  |
| Measurement recorder         | <ul style="list-style-type: none"> <li>Disabled</li> <li>Enabled</li> </ul>   | Disabled    | Enables the measurement recorder tool, further configured in <i>Tools</i> → <i>Misc</i> → <i>Measurement recorder</i> .  |
| I/O default object selection | <ul style="list-style-type: none"> <li>OBJ1</li> <li>OBJ2</li> <li>OBJ3</li> <li>OBJ4</li> <li>OBJ5</li> <li>OBJ6</li> <li>OBJ7</li> <li>OBJ8</li> <li>OBJ9</li> <li>OBJ10</li> </ul> | OBJ1        | "I" and "0" push buttons on the front panel of the device have an indication LED. This parameter defines which objects' status push buttons follow when lighting up the LEDs.  |

| Name              | Range  | Default | Description   |
|-------------------|--|---------|---|
| Device Mode       | <ul style="list-style-type: none"> <li>• On</li> <li>• Blocked</li> <li>• Test</li> <li>• Test/Blocked</li> <li>• Off</li> </ul> | On      | Set mode of device block.<br>This parameter is visible only when <i>Allow setting of device mode</i> is enabled in <i>General</i> menu. |
| Reconfigure mimic | <ul style="list-style-type: none"> <li>• -</li> <li>• Reconfigure</li> </ul>   | -       | Reloads the mimic to the unit.  |

Table. 4.3 - 50. General menu logical inputs.

| Name  | Description  |
|---|--|
| Reset last fault registers                    | Signal set to this point can be used for resetting latest recorded fault register.   |
| Reset latches                                 | Signals set to this point can be used for resetting latched signals. An alternative to using the "Back" button on the front panel of the device. |
| Ph.Rotating Logic control<br>0=A-B-C, 1=A-C-B | Signals set to this point can be used for switching the expected phase rotating order.   |

## 4.4 Protection functions

### 4.4.1 General properties of a protection function

The following flowchart describes the basic structure of any protection function. The basic structure is composed of analog measurement values being compared to the pick-up values and operating time delay characteristics.

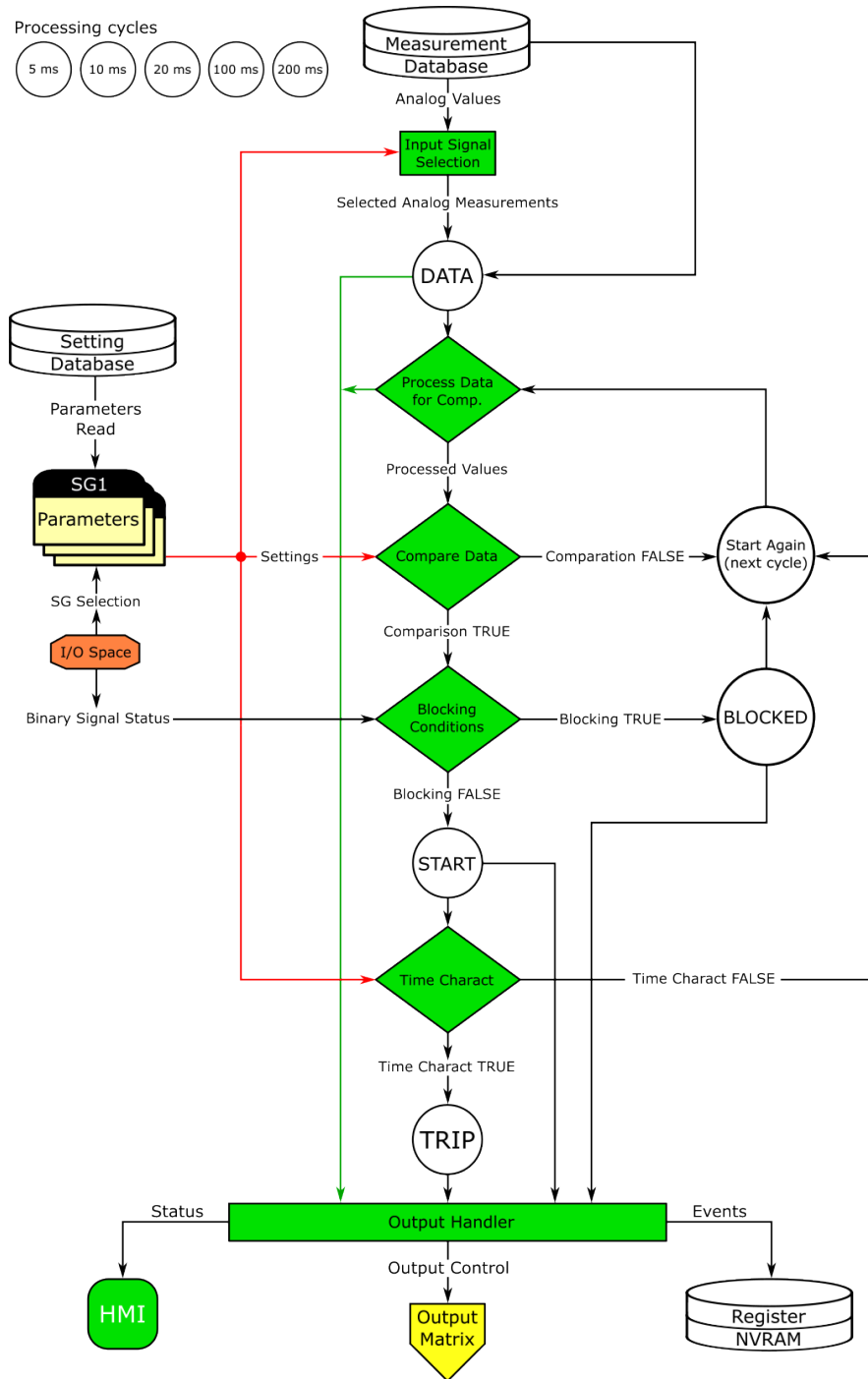

The protection function is run in a completely digital environment with a protection CPU microprocessor which also processes the analog signals transformed into the digital form.

In the following chapters the common functionalities of protection functions are described. If a protection function deviates from this basic structure, the difference is described in the corresponding chapter of the manual.

## Pick-up

The  $X_{set}$  parameter defines the pick-up level of the function, and this in turn defines the maximum or minimum allowed measured magnitude (in per unit, absolute or percentage value) before the function takes action. The function constantly calculates the ratio between the pick-up parameter set by the user and the measured magnitude ( $X_m$ ). The reset ratio of 97 % is built into the function and is always relative to the  $X_{set}$  value. If a function's pick-up characteristics vary from this description, they are defined in the function section in the manual.

Figure. 4.4.1 - 20. Pick up and reset.

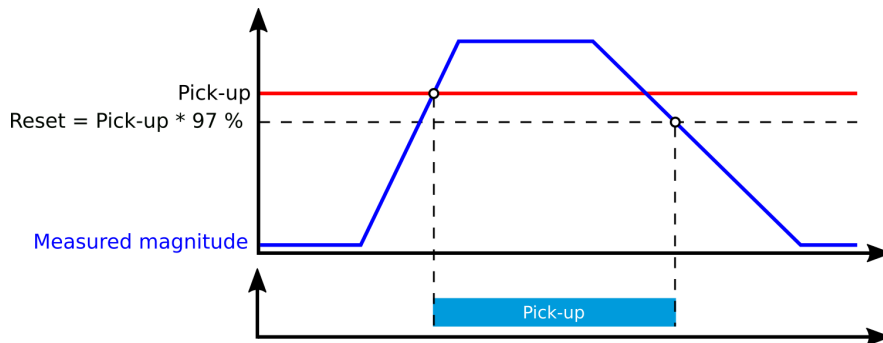
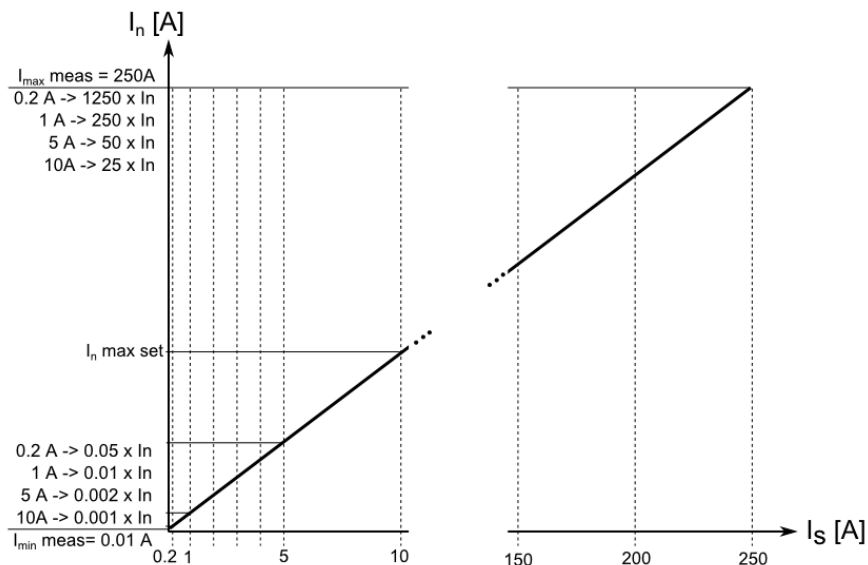

Figure. 4.4.1 - 21. Measurement range in relation to the nominal current.



The  $I_n$  magnitude refers to the user set nominal current which can range from 0.2...10 A, typically 0.2 A, 1A or 5 A. With its own current measurement card, the device will measure secondary currents from 0.001 A up to 250 A. To this relation the pick-up setting in secondary amperes will vary.

## Function blocking

The blocking signal is evaluated at the start of each program cycle. The blocking signals are connected to the function's dedicated input, which can be configured in the *IO* → *Blocking Input Control* tab of the function.

- When the pick-up element activates and the blocking signal is not active, a START signal is generated, and the function starts or continues with the trip time countdown.
- When the pick-up element activates and the blocking signal is active, a BLOCKED signal is generated, and the function does not process the event further.

- When a START signal is already active and the blocking input signal becomes active, the START signal is reset and BLOCKED signal is generated. The release time characteristics are then processed in the same way as when the pick-up signal is reset.

The blocking signal needs to reach the device minimum of 5 ms before the set operating delay has passed in order for the blocking to activate in time. Blocking of the function causes a time stamped blocking event with information of the startup current values and its fault type to be issued.

Some functions also offer an optional internal inrush harmonic blocking feature. If the inrush harmonic pick-up is active at the same time as the protection function pick-up element, the trip delay timer continues counting down as normal. Once the countdown reaches zero, if the pick-up element remains active and the second harmonic value has dropped, the function issues a trip.

Table. 4.4.1 - 51. Internal inrush harmonic blocking settings.

| Name  | Range   | Step                   | Default  | Description   |
|---|---|------------------------|--|---|
| Inrush harmonic blocking (internal-only trip)                                   | <ul style="list-style-type: none"> <li>• No</li> <li>• Yes</li> </ul> | -                      | <ul style="list-style-type: none"> <li>• No</li> </ul> | Enables and disables the 2 <sup>nd</sup> harmonic blocking. |
| 2 <sup>nd</sup> harmonic blocking limit (I <sub>harm</sub> /I <sub>fund</sub> ) | 0.10...50.00%I <sub>fund</sub>  | 0.01%I <sub>fund</sub> | 0.01%I <sub>fund</sub>                                 | Defines the limit of the 2 <sup>nd</sup> harmonic blocking. |

## Operating time characteristics

Three basic modes are available for delaying function operation:

- Instant operation: activates the trip signal simultaneously with the start signal with no additional time delay.
- Definite time operation (DT): activates the trip signal after a user-defined time delay regardless of the magnitude of the measured value(s) as long as the pick-up element is active.
- Inverse definite minimum time (IDMT): activates the trip signal after a time which is in relation to the set pick-up value and the measured value.

Both IEC and IEEE/ANSI standard characteristics as well as user settable parameters are available for the IDMT operation. Please note that in the IDMT mode *Definite (minimum) operating time delay* also determines the minimum time for protection tripping (see the figure below). If this function is not desired the parameter should be set to 0 seconds.

Figure. 4.4.1 - 22. Operating time delay: *Definite (minimum) operating time delay* and the minimum for tripping.

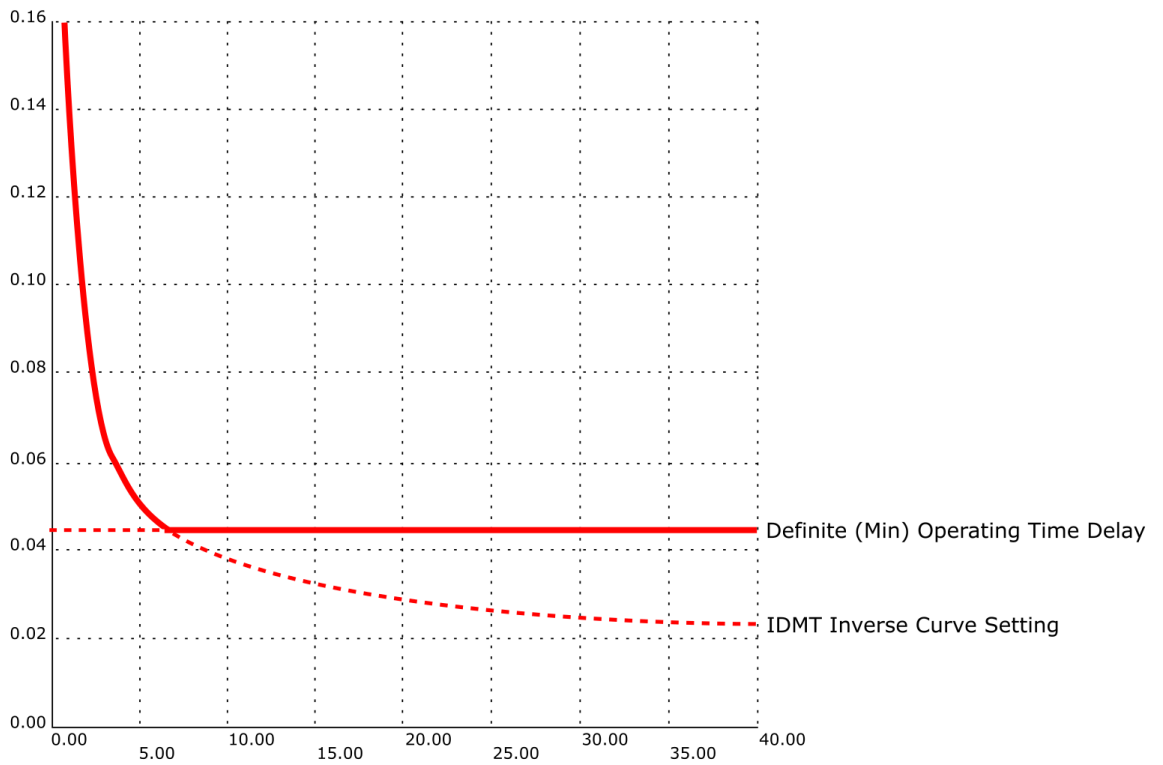

Table. 4.4.1 - 52. Operating time characteristics setting parameters (general).

| Name                                    | Range   | Step   | Default | Description   |
|---|---|--------|---------|---|
| Delay type                              | <ul style="list-style-type: none"> <li>DT</li> <li>IDMT</li> </ul>  | -      | DT      | Selects the delay type for the time counter. The selection is made between "Inverse definite minimum time" (IDMT) and "Definite time operation" (DT) characteristics.   |
| Definite (minimum) operating time delay | 0.000...1800.000s   | 0.005s | 0.040s  | When the "Delay type" parameter is set to "DT", this parameter acts as the expected operating time for the protection function.<br>When set to 0 s, the stage operates instantaneously without any additional delay. When the parameter is set to 0.005...1800 s, the stage operates as independent delayed.<br>When the "Delay type" parameter has been set to "IDMT", this parameter can be used to determine the minimum operating time for the protection function. Example of this is presented in the figure above. |
| Delay curve series                      | <ul style="list-style-type: none"> <li>IEC</li> <li>IEEE</li> </ul> | -      | IEC     | Selects whether the delay curve series for an IDMT operation follows either IEC or IEEE/ANSI standard defined characteristics.<br>This setting is active and visible when the "Delay type" parameter is set to "IDMT".  |

| Name                       | Range   | Step   | Default | Description  |
|----------------------------|---|--------|---------|--|
| Delay characteristics IEC  | <ul style="list-style-type: none"> <li>• NI</li> <li>• EI</li> <li>• VI</li> <li>• LTI</li> <li>• Param</li> </ul>  | -      | NI      | <p>Selects the IEC standard delay characteristics. The options include the following: Normally Inverse ("NI"), Extremely Inverse ("EI"), Very Inverse ("VI") and Long Time Inverse ("LTI") characteristics. Additionally, the "Param" option allows the tuning of the constants A and B which then allows the setting of characteristics following the same formula as the IEC curves mentioned here.</p> <p>This setting is active and visible when the "Delay type" parameter is set to "IDMT" and the "Delay curve series" parameter is set to "IEC".</p>   |
| Delay characteristics IEEE | <ul style="list-style-type: none"> <li>• ANSI NI</li> <li>• ANSI VI</li> <li>• ANSI EI</li> <li>• ANSI LTI</li> <li>• IEEE MI</li> <li>• IEEE VI</li> <li>• IEEE EI</li> <li>• Param</li> </ul> | -      | ANSI NI | <p>Selects the IEEE and ANSI standard delay characteristics. The options for ANSI include the following: Normal Inverse ("ANSI NI"), Very Inverse ("ANSI VI"), Extremely inverse ("ANSI EI"), Long time inverse ("ANSI LTI") characteristics. IEEE: Moderately Inverse ("IEEE MI"), Very Inverse ("IEEE VI"), Extremely Inverse ("IEEE EI") characteristics. Additionally, the "Param" option allows the tuning of the constants A, B and C which then allows the setting of characteristics following the same formula as the IEEE curves mentioned here.</p> <p>This setting is active and visible when the "Delay type" parameter is set to "IDMT" and the "Delay curve series" parameter is set to "IEEE".</p> |
| Time dial setting k        | 0.01...25.00s   | 0.01s  | 0.05s   | <p>Defines the time dial/multiplier setting for IDMT characteristics. This setting is active and visible when the "Delay type" parameter is set to "IDMT".</p>   |
| A                          | 0.0000...250.0000   | 0.0001 | 0.0860  | <p>Defines the Constant A for IEC/IEEE characteristics. This setting is active and visible when the "Delay type" parameter is set to "IDMT" and the "Delay characteristic" parameter is set to "Param".</p>  |
| B                          | 0.0000...250.0000   | 0.0001 | 0.1850  | <p>Defines the Constant B for IEC/IEEE characteristics. This setting is active and visible when the "Delay type" parameter is set to "IDMT" and the "Delay characteristic" parameter is set to "Param".</p>  |
| C                          | 0.0000...250.0000   | 0.0001 | 0.0200  | <p>Defines the Constant C for IEEE characteristics. This setting is active and visible when the "Delay type" parameter is set to "IDMT" and the "Delay characteristic" parameter is set to "Param".</p>  |

Figure. 4.4.1 - 23. Inverse definite minimum time formulas for IEC and IEEE standards.

| IEC  | IEEE/ANSI   |         |       |                       |      |      |                        |    |   |                   |      |   |                         |     |   |   |      |   |   |   |                       |       |        |       |                   |       |        |   |                        |      |         |   |                         |       |       |   |      |   |   |   |                         |        |       |      |                   |       |       |   |                        |      |        |   |
|--|---|---------|-------|-----------------------|------|------|------------------------|----|---|-------------------|------|---|-------------------------|-----|---|---|------|---|---|---|-----------------------|-------|--------|-------|-------------------|-------|--------|---|------------------------|------|---------|---|-------------------------|-------|-------|---|------|---|---|---|-------------------------|--------|-------|------|-------------------|-------|-------|---|------------------------|------|--------|---|
| $t = \frac{kA}{\left(\frac{I_m}{I_{set}}\right)^B - 1}$  | $t = k \left( \frac{A}{\left(\frac{I_m}{I_{set}}\right)^C - 1} + B \right)$   |         |       |                       |      |      |                        |    |   |                   |      |   |                         |     |   |   |      |   |   |   |                       |       |        |       |                   |       |        |   |                        |      |         |   |                         |       |       |   |      |   |   |   |                         |        |       |      |                   |       |       |   |                        |      |        |   |
| <p><i>t</i> = Operating delay (s)<br/> <i>k</i> = Time dial setting<br/> <i>I<sub>m</sub></i> = Measured maximum current<br/> <i>I<sub>set</sub></i> = Pick-up setting<br/> <i>A</i> = Operating characteristics constant<br/> <i>B</i> = Operating characteristics constant</p>   | <p><i>t</i> = Operating delay (s)<br/> <i>k</i> = Time dial setting<br/> <i>I<sub>m</sub></i> = Measured maximum current<br/> <i>I<sub>set</sub></i> = Pick-up setting<br/> <i>A</i> = Operating characteristics constant<br/> <i>B</i> = Operating characteristics constant<br/> <i>C</i> = Operating characteristics constant</p> |         |       |                       |      |      |                        |    |   |                   |      |   |                         |     |   |   |      |   |   |   |                       |       |        |       |                   |       |        |   |                        |      |         |   |                         |       |       |   |      |   |   |   |                         |        |       |      |                   |       |       |   |                        |      |        |   |
| <p>Standard delays IEC constants</p> <table border="1"> <thead> <tr> <th>Type</th> <th>A</th> <th>B</th> </tr> </thead> <tbody> <tr> <td>Normally Inverse (NI)</td> <td>0,14</td> <td>0,02</td> </tr> <tr> <td>Extremely Inverse (EI)</td> <td>80</td> <td>2</td> </tr> <tr> <td>Very Inverse (VI)</td> <td>13,5</td> <td>1</td> </tr> <tr> <td>Long Time Inverse (LTI)</td> <td>120</td> <td>1</td> </tr> </tbody> </table> | Type  | A       | B     | Normally Inverse (NI) | 0,14 | 0,02 | Extremely Inverse (EI) | 80 | 2 | Very Inverse (VI) | 13,5 | 1 | Long Time Inverse (LTI) | 120 | 1 | <p>Standard delays ANSI constants</p> <table border="1"> <thead> <tr> <th>Type</th> <th>A</th> <th>B</th> <th>C</th> </tr> </thead> <tbody> <tr> <td>Normally Inverse (NI)</td> <td>8,934</td> <td>0,1797</td> <td>2,094</td> </tr> <tr> <td>Very Inverse (VI)</td> <td>3,922</td> <td>0,0982</td> <td>2</td> </tr> <tr> <td>Extremely Inverse (EI)</td> <td>5,64</td> <td>0,02434</td> <td>2</td> </tr> <tr> <td>Long Time Inverse (LTI)</td> <td>5,614</td> <td>2,186</td> <td>1</td> </tr> </tbody> </table> <p>Standard delays IEEE constants</p> <table border="1"> <thead> <tr> <th>Type</th> <th>A</th> <th>B</th> <th>C</th> </tr> </thead> <tbody> <tr> <td>Moderately Inverse (MI)</td> <td>0,0515</td> <td>0,114</td> <td>0,02</td> </tr> <tr> <td>Very Inverse (VI)</td> <td>19,61</td> <td>0,491</td> <td>2</td> </tr> <tr> <td>Extremely Inverse (EI)</td> <td>28,2</td> <td>0,1217</td> <td>2</td> </tr> </tbody> </table> | Type | A | B | C | Normally Inverse (NI) | 8,934 | 0,1797 | 2,094 | Very Inverse (VI) | 3,922 | 0,0982 | 2 | Extremely Inverse (EI) | 5,64 | 0,02434 | 2 | Long Time Inverse (LTI) | 5,614 | 2,186 | 1 | Type | A | B | C | Moderately Inverse (MI) | 0,0515 | 0,114 | 0,02 | Very Inverse (VI) | 19,61 | 0,491 | 2 | Extremely Inverse (EI) | 28,2 | 0,1217 | 2 |
| Type   | A   | B       |       |                       |      |      |                        |    |   |                   |      |   |                         |     |   |   |      |   |   |   |                       |       |        |       |                   |       |        |   |                        |      |         |   |                         |       |       |   |      |   |   |   |                         |        |       |      |                   |       |       |   |                        |      |        |   |
| Normally Inverse (NI)  | 0,14  | 0,02    |       |                       |      |      |                        |    |   |                   |      |   |                         |     |   |   |      |   |   |   |                       |       |        |       |                   |       |        |   |                        |      |         |   |                         |       |       |   |      |   |   |   |                         |        |       |      |                   |       |       |   |                        |      |        |   |
| Extremely Inverse (EI)   | 80  | 2       |       |                       |      |      |                        |    |   |                   |      |   |                         |     |   |   |      |   |   |   |                       |       |        |       |                   |       |        |   |                        |      |         |   |                         |       |       |   |      |   |   |   |                         |        |       |      |                   |       |       |   |                        |      |        |   |
| Very Inverse (VI)  | 13,5  | 1       |       |                       |      |      |                        |    |   |                   |      |   |                         |     |   |   |      |   |   |   |                       |       |        |       |                   |       |        |   |                        |      |         |   |                         |       |       |   |      |   |   |   |                         |        |       |      |                   |       |       |   |                        |      |        |   |
| Long Time Inverse (LTI)  | 120   | 1       |       |                       |      |      |                        |    |   |                   |      |   |                         |     |   |   |      |   |   |   |                       |       |        |       |                   |       |        |   |                        |      |         |   |                         |       |       |   |      |   |   |   |                         |        |       |      |                   |       |       |   |                        |      |        |   |
| Type   | A   | B       | C     |                       |      |      |                        |    |   |                   |      |   |                         |     |   |   |      |   |   |   |                       |       |        |       |                   |       |        |   |                        |      |         |   |                         |       |       |   |      |   |   |   |                         |        |       |      |                   |       |       |   |                        |      |        |   |
| Normally Inverse (NI)  | 8,934   | 0,1797  | 2,094 |                       |      |      |                        |    |   |                   |      |   |                         |     |   |   |      |   |   |   |                       |       |        |       |                   |       |        |   |                        |      |         |   |                         |       |       |   |      |   |   |   |                         |        |       |      |                   |       |       |   |                        |      |        |   |
| Very Inverse (VI)  | 3,922   | 0,0982  | 2     |                       |      |      |                        |    |   |                   |      |   |                         |     |   |   |      |   |   |   |                       |       |        |       |                   |       |        |   |                        |      |         |   |                         |       |       |   |      |   |   |   |                         |        |       |      |                   |       |       |   |                        |      |        |   |
| Extremely Inverse (EI)   | 5,64  | 0,02434 | 2     |                       |      |      |                        |    |   |                   |      |   |                         |     |   |   |      |   |   |   |                       |       |        |       |                   |       |        |   |                        |      |         |   |                         |       |       |   |      |   |   |   |                         |        |       |      |                   |       |       |   |                        |      |        |   |
| Long Time Inverse (LTI)  | 5,614   | 2,186   | 1     |                       |      |      |                        |    |   |                   |      |   |                         |     |   |   |      |   |   |   |                       |       |        |       |                   |       |        |   |                        |      |         |   |                         |       |       |   |      |   |   |   |                         |        |       |      |                   |       |       |   |                        |      |        |   |
| Type   | A   | B       | C     |                       |      |      |                        |    |   |                   |      |   |                         |     |   |   |      |   |   |   |                       |       |        |       |                   |       |        |   |                        |      |         |   |                         |       |       |   |      |   |   |   |                         |        |       |      |                   |       |       |   |                        |      |        |   |
| Moderately Inverse (MI)  | 0,0515  | 0,114   | 0,02  |                       |      |      |                        |    |   |                   |      |   |                         |     |   |   |      |   |   |   |                       |       |        |       |                   |       |        |   |                        |      |         |   |                         |       |       |   |      |   |   |   |                         |        |       |      |                   |       |       |   |                        |      |        |   |
| Very Inverse (VI)  | 19,61   | 0,491   | 2     |                       |      |      |                        |    |   |                   |      |   |                         |     |   |   |      |   |   |   |                       |       |        |       |                   |       |        |   |                        |      |         |   |                         |       |       |   |      |   |   |   |                         |        |       |      |                   |       |       |   |                        |      |        |   |
| Extremely Inverse (EI)   | 28,2  | 0,1217  | 2     |                       |      |      |                        |    |   |                   |      |   |                         |     |   |   |      |   |   |   |                       |       |        |       |                   |       |        |   |                        |      |         |   |                         |       |       |   |      |   |   |   |                         |        |       |      |                   |       |       |   |                        |      |        |   |

### Non-standard delay characteristics

In addition to the previously mentioned delay characteristics, some functions also have delay characteristics that deviate from the IEC or IEEE standards. These functions are the following:

- non-directional overcurrent stages
- non-directional earth fault stages
- directional overcurrent stages
- directional earth fault stages.

The setting parameters and their ranges are documented in the chapters of the respective function blocks.

Table. 4.4.1 - 53. Inverse definite minimum time formulas for nonstandard characteristics.

| RI-type  | RD-type  |
|--|--|
| Used for getting the time grading with mechanical relays.  | Mostly used in earth fault protection which grants selective tripping even in non-directional protection.  |
| $t = \frac{k}{0.339 - 0.236 * \frac{I_{set}}{I_m}}$  | $t = 5.8 - 1.35 * \ln \left( \frac{I_m}{k * I_{set}} \right)$  |
| <p><i>t</i> = Operation delay (s)<br/> <i>k</i> = Time dial setting<br/> <i>I<sub>m</sub></i> = Measured maximum current<br/> <i>I<sub>set</sub></i> = Pick-up setting</p> | <p><i>t</i> = Operation delay (s)<br/> <i>k</i> = Time dial setting<br/> <i>I<sub>m</sub></i> = Measured maximum current<br/> <i>I<sub>set</sub></i> = Pick-up setting</p> |



**NOTICE!**

When using RD-type and "k" has been set lower than 0.3 calculated operation time can be lower than 0 seconds with some measurement values. In these cases operation time will be instant.

When using the release delay option where the operating time counter is calculating the operating time during the release time, the function will not trip if the input signal is not activated again during the release time counting.

The behavior of the stages with different release time configurations are presented in the figures below.

Table. 4.4.1 - 54. Setting parameters for reset time characteristics.

| Name  | Range   | Step   | Default | Description   |
|---|---|--------|---------|---|
| Delayed pick-up release                       | <ul style="list-style-type: none"> <li>No</li> <li>Yes</li> </ul> | -      | Yes     | Resetting characteristics selection (either time-delayed or instant) after the pick-up element is released. If set to "Yes", the START signal is reset after a set release time delay.  |
| Release time delay                            | 0.000...150.000s  | 0.005s | 0.06s   | Resetting time. The time allowed between pick-ups if the pick-up has not led into a trip operation. If the "Delayed pick-up release" setting is set to "Yes", the START signal is held on for the duration of the timer.  |
| Op.Time calculation reset after release time  | <ul style="list-style-type: none"> <li>No</li> <li>Yes</li> </ul> | -      | Yes     | Operating timer resetting characteristics selection. When set to "Yes", the operating time counter is reset after a set release time if the pick-up element is not activated during this time. When set to "No", the operating time counter is reset directly after the pick-up element is reset. |
| Continue time calculation during release time | <ul style="list-style-type: none"> <li>No</li> <li>Yes</li> </ul> | -      | No      | Time calculation characteristics selection. If set to "Yes", the operating time counter continues until a set release time even if the pick-up element is reset.  |

Figure. 4.4.1 - 24. No delayed pick-up release.

**Delayed pick-up release: Disabled**

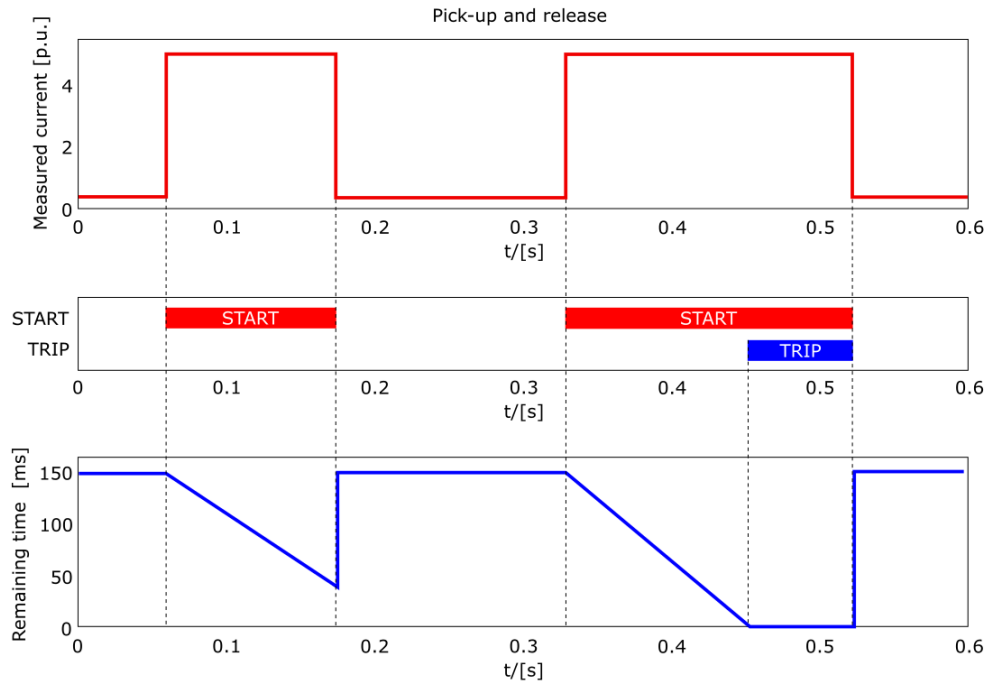

Figure. 4.4.1 - 25. Delayed pick-up release, delay counter is reset at signal drop-off.

**Delayed pick-up release: Enabled**  
Op.time calc reset after release time: Disabled  
Continue time calculation during release time: Disabled

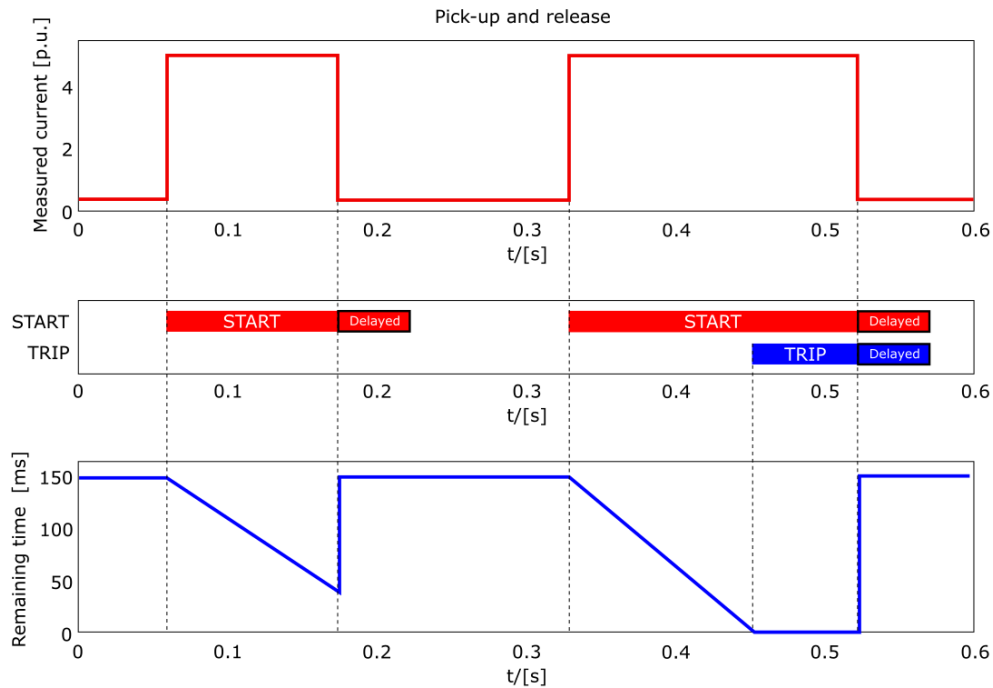

Figure. 4.4.1 - 26. Delayed pick-up release, delay counter value is held during the release time.

Delayed pick-up release: Enabled  
 Op.time calc reset after release time: Enabled  
 Continue time calculation during release time: Disabled

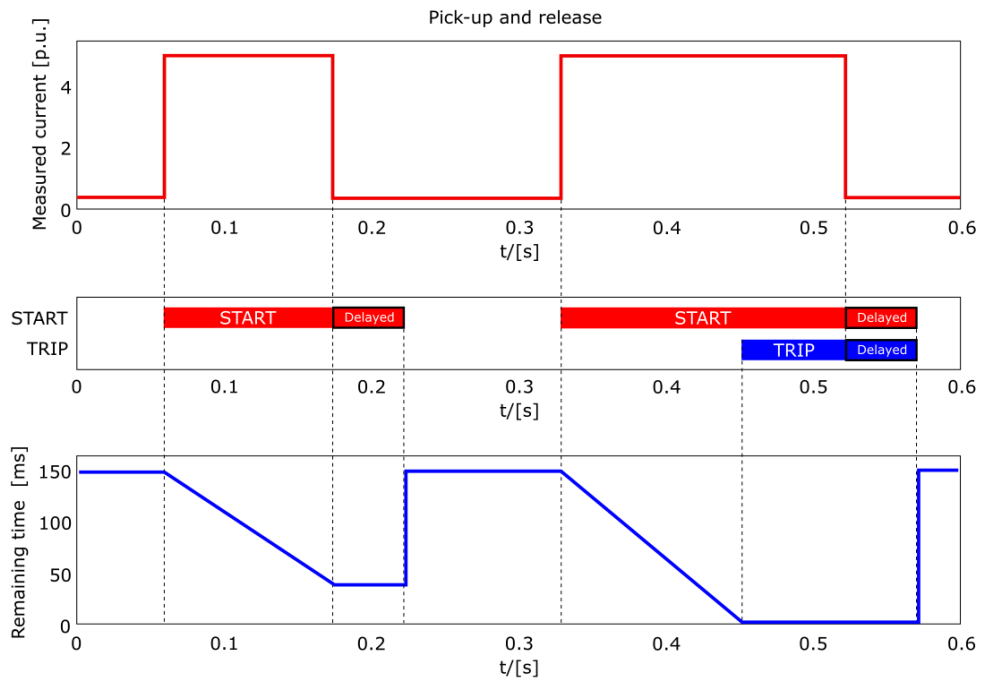
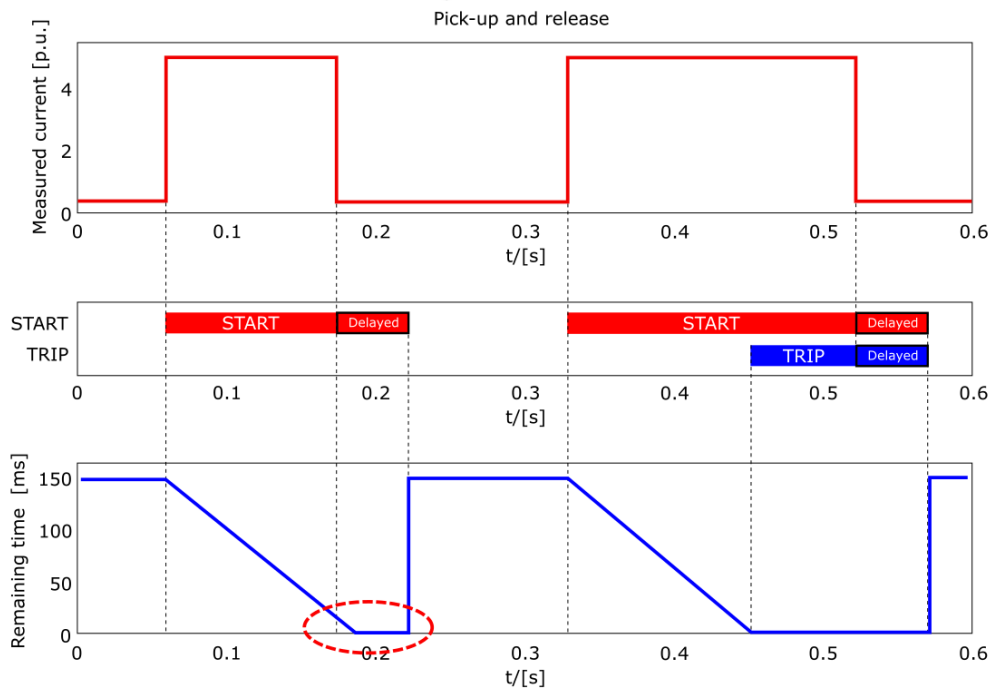

Figure. 4.4.1 - 27. Delayed pick-up release, delay counter value is decreasing during the release time.

Delayed pick-up release: Enabled  
 Op.time calc reset after release time: Enabled  
 Continue time calculation during release time: Enabled



## Stage forcing

It is possible to test the logic, event processing and the operation of the device's logic by controlling the state of the protection functions manually without injecting any current into the device with stage forcing. To enable *Stage forcing* set the *Enable stage forcing* to ENABLED in the *General* menu. After this it is possible to control the status of a protection function (Normal, Start, Trip, Blocked etc.) in the *Info* page of the function.



### NOTICE!

When *Stage forcing* is enabled protection functions will also change state through user input. Injected currents/voltages also affect the behavior of the device. Regardless, it is recommended to disable *Stage Forcing* after testing has ended.

## 4.4.2 Non-directional overcurrent protection ( $I >$ ; 50/51)

The non-directional overcurrent function is used for instant and time-delayed overcurrent and short-circuit protection. The function is used for one-phase, two-phase or three-phase overcurrent and short circuit protection. The function offers four (4) independent stages. The operating decisions are based on phase current magnitude, constantly measured by the function.

Figure. 4.4.2 - 28. Simplified function block diagram of the  $I >$  function.

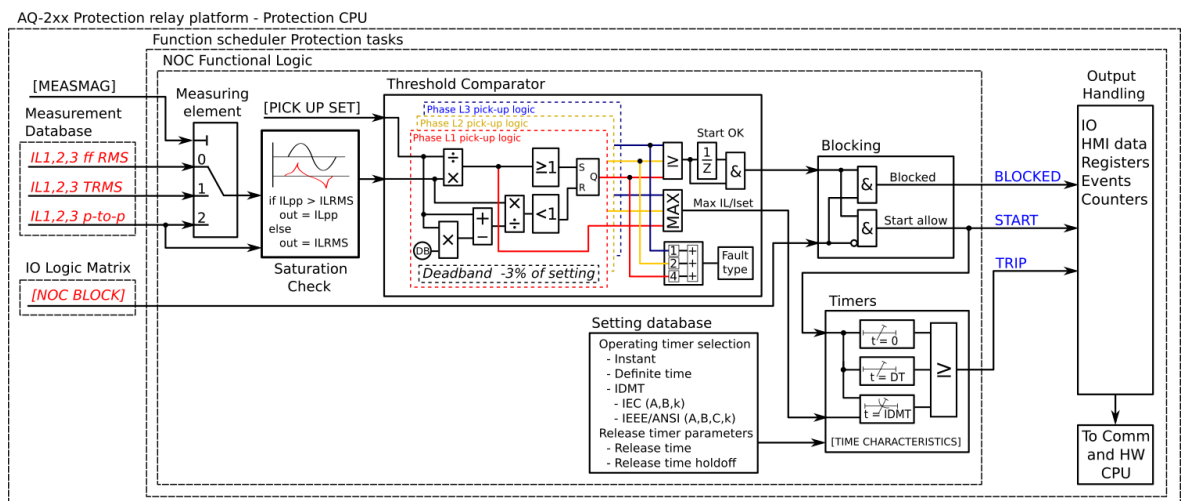

## Measured input

The function block uses phase current measurement values. The user can select the monitored magnitude to be equal either to RMS values (fundamental frequency component), to TRMS values from the whole harmonic specter of 32 components, or to peak-to-peak values.

Table. 4.4.2 - 55. Measurement inputs of the  $I >$  function.

| Signal       | Description   |
|--------------|---|
| $I_{L1}RMS$  | Fundamental frequency component of phase L1 (A) current measurement |
| $I_{L2}RMS$  | Fundamental frequency component of phase L2 (B) current measurement |
| $I_{L3}RMS$  | Fundamental frequency component of phase L3 (C) current measurement |
| $I_{L1}TRMS$ | TRMS measurement of phase L1 (A) current                            |

| Signal               | Description                                      |
|----------------------|--|
| I <sub>L2</sub> TRMS | TRMS measurement of phase L2 (B) current         |
| I <sub>L3</sub> TRMS | TRMS measurement of phase L3 (C) current         |
| I <sub>L1</sub> PP   | Peak-to-peak measurement of phase L1 (A) current |
| I <sub>L2</sub> PP   | Peak-to-peak measurement of phase L2 (B) current |
| I <sub>L3</sub> PP   | Peak-to-peak measurement of phase L3 (C) current |

## General settings

The following general settings define the general behavior of the function. These settings are static i.e. it is not possible to change them by editing the setting group.

Table. 4.4.2 - 56. General settings of the function.

| Name                          | Range   | Default  | Description  |
|-------------------------------|---|--|--|
| Setting control from comm bus | <ul style="list-style-type: none"> <li>Disabled</li> <li>Allowed</li> </ul>   | <ul style="list-style-type: none"> <li>Disabled</li> </ul> | Activating this parameter allows changing the pick-up level of the protection stage via SCADA.   |
| I> LN mode                    | <ul style="list-style-type: none"> <li>On</li> <li>Blocked</li> <li>Test</li> <li>Test/Blocked</li> <li>Off</li> </ul>  | <ul style="list-style-type: none"> <li>On</li> </ul>       | Set mode of NOC block. This parameter is visible only when <i>Allow setting of individual LN mode</i> is enabled in <i>General</i> menu. |
| I> force status to            | <ul style="list-style-type: none"> <li>Normal</li> <li>Start</li> <li>Trip</li> <li>Blocked</li> <li>Start A</li> <li>Start B</li> <li>Start C</li> <li>Trip A</li> <li>Trip B</li> <li>Trip C</li> <li>Start AB</li> <li>Start BC</li> <li>Start CA</li> <li>Start ABC</li> <li>Trip AB</li> <li>Trip BC</li> <li>Trip CA</li> <li>Trip ABC</li> </ul> | <ul style="list-style-type: none"> <li>Normal</li> </ul>   | Force the status of the function. Visible only when <i>Enable stage forcing</i> parameter is enabled in <i>General</i> menu.             |
| Measured magnitude            | <ul style="list-style-type: none"> <li>RMS</li> <li>TRMS</li> <li>Peak-to-peak</li> </ul>   | <ul style="list-style-type: none"> <li>RMS</li> </ul>      | Defines which available measured magnitude is used by the function.  |
| Measurement side              | <ul style="list-style-type: none"> <li>Side 1</li> <li>Side 2</li> </ul>  | <ul style="list-style-type: none"> <li>Side 1</li> </ul>   | Defines which current measurement module is used by the function.  |

## Pick-up settings

The  $I_{set}$  setting parameter controls the pick-up of the  $I>$  function. This defines the maximum allowed measured current before action from the function. The function constantly calculates the ratio between the  $I_{set}$  and the measured magnitude ( $I_m$ ) for each of the three phases. The reset ratio of 97 % is built into the function and is always relative to the  $I_{set}$  value. The setting value is common for all measured phases, and when the  $I_m$  exceeds the  $I_{set}$  value (in single, dual or all phases) it triggers the pick-up operation of the function.

Setting group selection controls the operating characteristics of the function, i.e. the user or user-defined logic can change function parameters while the function is running.

Table. 4.4.2 - 57. Pick-up settings.

| Name      | Range                         | Step              | Default           | Description     |
|-----------|-------------------------------|-------------------|-------------------|-----------------|
| $I_{set}$ | $0.10 \dots 50.00 \times I_n$ | $0.01 \times I_n$ | $1.20 \times I_n$ | Pick-up setting |

## Read-only parameters

The function's *Info* page displays useful, real-time information on the state of the protection function. It is accessed either through the device's HMI display, or through the setting tool software when it is connected to the device and its Live Edit mode is active.

Table. 4.4.2 - 58. Information displayed by the function.

| Name                  | Range   | Step | Description  |
|-----------------------|---|------|--|
| $I>$ LN behaviour     | <ul style="list-style-type: none"> <li>• On</li> <li>• Blocked</li> <li>• Test</li> <li>• Test/Blocked</li> <li>• Off</li> </ul>  | -    | Displays the mode of NOC block.<br>This parameter is visible only when <i>Allow setting of individual LN mode</i> is enabled in <i>General</i> menu. |
| $I>$ condition        | <ul style="list-style-type: none"> <li>• Normal</li> <li>• Start</li> <li>• Trip</li> <li>• Blocked</li> </ul>  | -    | Displays status of the protection function.  |
| $I>$ phases condition | <ul style="list-style-type: none"> <li>• Normal</li> <li>• Start A</li> <li>• Start B</li> <li>• Start C</li> <li>• Trip A</li> <li>• Trip B</li> <li>• Trip C</li> <li>• Start AB</li> <li>• Start BC</li> <li>• Start CA</li> <li>• Start ABC</li> <li>• Trip AB</li> <li>• Trip BC</li> <li>• Trip CA</li> <li>• Trip ABC</li> </ul> | -    | Displays the status of phases individually.  |

| Name                             | Range                 | Step   | Description   |
|----------------------------------|-----------------------|--------|---|
| Expected operating time          | 0.000...1800.000s     | 0.005s | Displays the expected operating time when a fault occurs. When IDMT mode is used, the expected operating time depends on the measured highest phase current value. If the measured current changes during a fault, the expected operating time changes accordingly. |
| Time remaining to trip           | -1800.000...1800.000s | 0.005s | When the function has detected a fault and counts down time towards a trip, this displays how much time is left before tripping occurs.   |
| $I_{meas}/I_{set}$ at the moment | 0.00...1250.00        | 0.01   | The ratio between the highest measured phase current and the pick-up value.   |

## Function blocking

The blocking signal is evaluated at the start of each program cycle. The blocking signals are connected to the function's dedicated input, which can be configured in the *IO → Blocking Input Control* tab of the function.

- When the pick-up element activates and the blocking signal is not active, a START signal is generated, and the function starts or continues with the trip time countdown.
- When the pick-up element activates and the blocking signal is active, a BLOCKED signal is generated, and the function does not process the event further.
- When a START signal is already active and the blocking input signal becomes active, the START signal is reset and BLOCKED signal is generated. The release time characteristics are then processed in the same way as when the pick-up signal is reset.

The blocking signal needs to reach the device minimum of 5 ms before the set operating delay has passed in order for the blocking to activate in time.

The function also offers an optional internal inrush harmonic blocking feature. If the inrush harmonic pick-up is active at the same time as the protection function pick-up element, the trip delay timer continues counting down as normal. Once the countdown reaches zero, if the pick-up element remains active and the second harmonic value has dropped, the function issues a trip.

Table. 4.4.2 - 59. Internal inrush harmonic blocking settings.

| Name  | Range   | Step             | Default  | Description   |
|---|---|------------------|--|---|
| Inrush harmonic blocking (internal-only trip)                   | <ul style="list-style-type: none"> <li>• No</li> <li>• Yes</li> </ul> | -                | <ul style="list-style-type: none"> <li>• No</li> </ul> | Enables and disables the 2 <sup>nd</sup> harmonic blocking. |
| 2 <sup>nd</sup> harmonic blocking limit ( $I_{harm}/I_{fund}$ ) | 0.10...50.00% $I_{fund}$  | 0.01% $I_{fund}$ | 0.01% $I_{fund}$                                       | Defines the limit of the 2 <sup>nd</sup> harmonic blocking. |

## Operating time characteristics for trip and reset

This function supports definite time delay (DT) and inverse definite minimum time delay (IDMT). For detailed information on these delay types please refer to the chapter "[General properties of a protection function](#)" and its section "[Operating time characteristics](#)".

Figure. 4.4.2 - 29. Typical operation time delays with different current to setting ratios in instant operation mode.

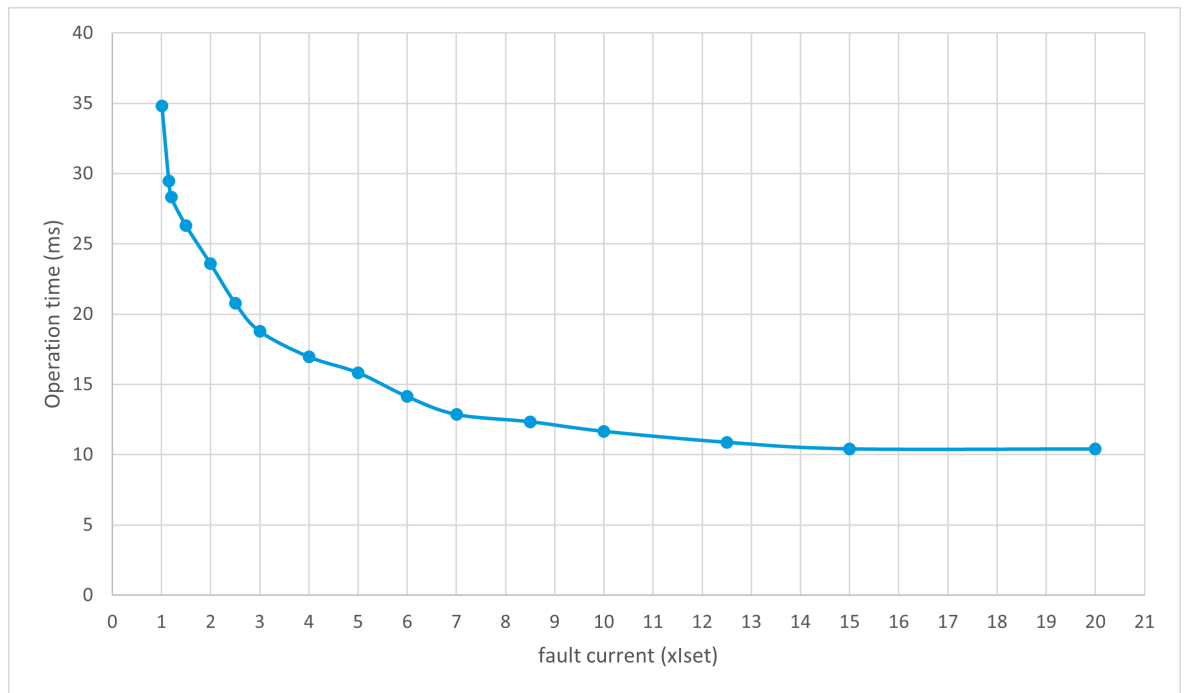

### Events and registers

The non-directional overcurrent function (abbreviated "NOC" in event block names) generates events and registers from the status changes in the events listed below. The user can select which event messages are stored in the main event buffer: ON, OFF, or both. The events triggered by the function are recorded with a time stamp.

The function's output can be used for direct I/O controlling and user logic programming. The function also provides a resettable cumulative counter for the START, TRIP and BLOCKED events.

Table. 4.4.2 - 60. Event messages.

| Event block name | Event names          |
|------------------|----------------------|
| NOC1...NOC4      | Start ON/OFF         |
| NOC1...NOC4      | Trip ON/OFF          |
| NOC1...NOC4      | Block ON/OFF         |
| NOC1...NOC4      | Phase A Start ON/OFF |
| NOC1...NOC4      | Phase B Start ON/OFF |
| NOC1...NOC4      | Phase C Start ON/OFF |
| NOC1...NOC4      | Phase A Trip ON/OFF  |
| NOC1...NOC4      | Phase B Trip ON/OFF  |
| NOC1...NOC4      | Phase C Trip ON/OFF  |

The function registers its operation into the last twelve (12) time-stamped registers; this information is available for all provided instances separately. The register of the function records the ON event process data for START, TRIP or BLOCKED. The table below presents the structure of the function's register content.

Table. 4.4.2 - 61. Register content.

| Name                 | Description                 |
|----------------------|-----------------------------|
| Date and time        | dd.mm.yyyy hh:mm:ss.mss     |
| Event                | Event name                  |
| Fault type           | L1-E...L1-L2-L3             |
| Pre-trigger current  | Start/Trip -20ms current    |
| Fault current        | Start/Trip current          |
| Pre-fault current    | Start -200ms current        |
| Trip time remaining  | 0 ms...1800s                |
| Setting group in use | Setting group 1...8 active. |

### 4.4.3 Non-directional earth fault protection (I0>; 50N/51N)

The non-directional earth fault function is used for instant and time-delayed earth fault protection. The number of stages in the function depend on the device model. The operating characteristics are based on the selected neutral current magnitude which the function measures constantly.

Figure. 4.4.3 - 30. Simplified function block diagram of the I0> function.

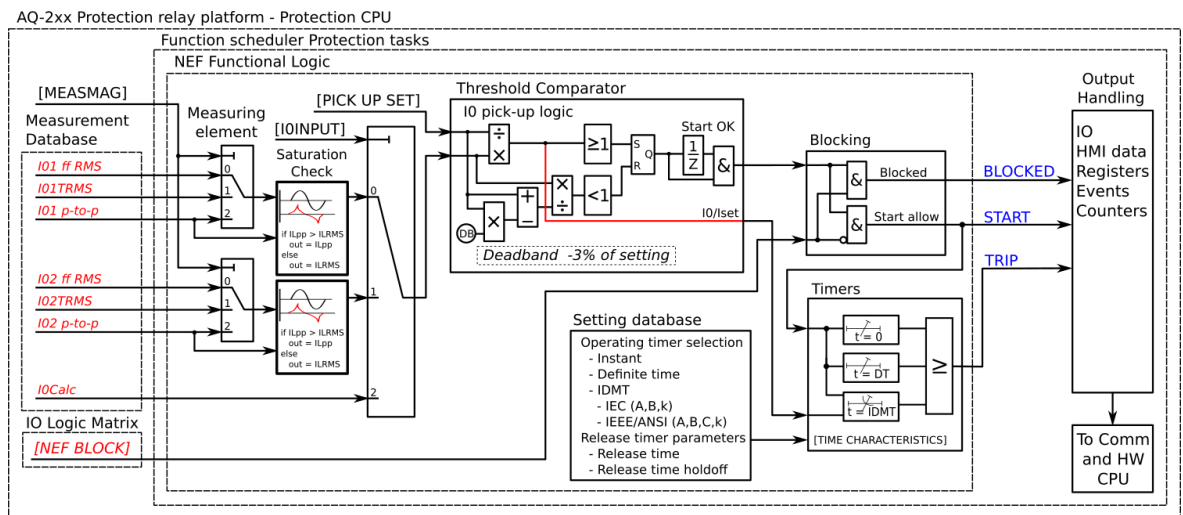

#### Measured input

The function block uses residual current measurement values. The available analog measurement channels are I01 and I02 (residual current measurement) and I0Calc (residual current calculated from phase current). The user can select the monitored magnitude to be equal either to RMS values (fundamental frequency component), to TRMS values from the whole harmonic specter of 32 components, or to peak-to-peak values.

Table. 4.4.3 - 62. Measurement inputs of the I0&gt; function.

| Signal  | Description  |
|---------|--|
| I01RMS  | Fundamental frequency component of coarse residual current measurement input I01                                 |
| I01TRMS | TRMS measurement of coarse residual current measurement input I01  |
| I01PP   | Peak-to-peak measurement of coarse residual current measurement input I01  |
| I02RMS  | Fundamental frequency component of sensitive residual current measurement input I02                              |
| I02TRMS | TRMS measurement of coarse sensitive current measurement input I02   |
| I02PP   | Peak-to-peak measurement of sensitive residual current measurement input I02                                     |
| I0Calc  | Fundamental frequency component of the calculated zero sequence current calculated from the three phase currents |

## General settings

The following general settings define the general behavior of the function. These settings are static i.e. it is not possible to change them by editing the setting group.

Table. 4.4.3 - 63. General settings of the function.

| Name                          | Range  | Default  | Description  |
|-------------------------------|--|----------|--|
| Setting control from comm bus | <ul style="list-style-type: none"> <li>Disabled</li> <li>Allowed</li> </ul>  | Disabled | Activating this parameter permits changing the pick-up level of the protection stage via SCADA.  |
| I0> LN mode                   | <ul style="list-style-type: none"> <li>On</li> <li>Blocked</li> <li>Test</li> <li>Test/Blocked</li> <li>Off</li> </ul> | On       | Set mode of NEF block. This parameter is visible only when Allow setting of individual LN mode is enabled in General menu.                             |
| I0> force status to           | <ul style="list-style-type: none"> <li>Normal</li> <li>Start</li> <li>Trip</li> <li>Blocked</li> </ul>                 | Normal   | Force the status of the function. Visible only when <i>Enable stage forcing</i> parameter is enabled in <i>General</i> menu.                           |
| Measured magnitude            | <ul style="list-style-type: none"> <li>RMS</li> <li>TRMS</li> <li>Peak-to-peak</li> </ul>                              | RMS      | Defines which available measured magnitude is used by the function. This parameter is available when "Input selection" has been set to "I01" or "I02". |
| Measurement side              | <ul style="list-style-type: none"> <li>Side 1</li> <li>Side 2</li> </ul>   | Side 1   | Defines which current measurement module is used by the function.  |
| Input selection               | <ul style="list-style-type: none"> <li>I01</li> <li>I02</li> <li>I0Calc</li> </ul>                                     | I01      | Defines which measured residual current is used by the function.   |

## Pick-up settings

The  $I_{Oset}$  setting parameter controls the the pick-up of the  $I_{O>}$  function. This defines the maximum allowed measured current before action from the function. The function constantly calculates the ratio between the  $I_{Oset}$  and the measured magnitude ( $I_m$ ) for each of the three phases. The reset ratio of 97 % is built into the function and is always relative to the  $I_{Oset}$  value. The setting value is common for all measured phases. When the  $I_m$  exceeds the  $I_{Oset}$  value (in single, dual or all phases) it triggers the pick-up operation of the function.

Setting group selection controls the operating characteristics of the function, i.e. the user or user-defined logic can change function parameters while the function is running.

Table. 4.4.3 - 64. Pick-up settings.

| Name       | Range                           | Step                | Default           | Description     |
|------------|---------------------------------|---------------------|-------------------|-----------------|
| $I_{Oset}$ | $0.0001 \dots 40.00 \times I_n$ | $0.0001 \times I_n$ | $1.20 \times I_n$ | Pick-up setting |

## Read-only parameters

The function's *Info* page displays useful, real-time information on the state of the protection function. It is accessed either through the device's HMI display, or through the setting tool software when it is connected to the device and its Live Edit mode is active.

Table. 4.4.3 - 65. Information displayed by the function.

| Name                    | Range   | Step     | Description   |
|-------------------------|---|----------|---|
| $I_{O>}$ LN behaviour   | <ul style="list-style-type: none"> <li>On</li> <li>Blocked</li> <li>Test</li> <li>Test/Blocked</li> <li>Off</li> </ul>                        | -        | Displays the mode of NEF block. This parameter is visible only when <i>Allow setting of individual LN mode</i> is enabled in <i>General</i> menu.   |
| $I_{O>}$ condition      | <ul style="list-style-type: none"> <li>Normal</li> <li>Start</li> <li>Trip</li> <li>Blocked</li> </ul>  | -        | Displays status of the protection function.   |
| Detected $I_{O}$ angle  | $-360.00 \dots 360.00$ deg  | 0.01 deg | Angle of $I_{O}$ against reference. If phase voltages are available, positive sequence voltage angle is used as reference. If voltages are not available, positive sequence current angle is used as reference.                                       |
| Detected fault type     | <ul style="list-style-type: none"> <li>-</li> <li>A-G-R</li> <li>B-G-F</li> <li>C-G-R</li> <li>A-G-F</li> <li>B-G-R</li> <li>C-G-F</li> </ul> | -        | Displays the detected fault type and direction of previous fault. "A/B/C" stand for one of the three phases. "G" stands for "ground". "F" stands for "forward" direction and "R" stands for "reverse" direction.                                      |
| Expected operating time | $-1800.000 \dots 1800.000$ s  | 0.005 s  | Displays the expected operating time when a fault occurs. When IDMT mode is used, the expected operating time depends on the measured current value. If the measured current changes during a fault, the expected operating time changes accordingly. |

| Name                             | Range              | Step    | Description   |
|----------------------------------|--------------------|---------|---|
| Time remaining to trip           | 0.000...1800.000 s | 0.005 s | When the function has detected a fault and counts down time towards a trip, this displays how much time is left before tripping occurs. |
| $I_{meas}/I_{set}$ at the moment | 0.00...1250.00     | 0.01    | The ratio between the measured current and the pick-up value.   |

## Function blocking

The blocking signal is evaluated at the start of each program cycle. The blocking signals are connected to the function's dedicated input, which can be configured in the *IO* → *Blocking Input Control* tab of the function.

- When the pick-up element activates and the blocking signal is not active, a START signal is generated, and the function starts or continues with the trip time countdown.
- When the pick-up element activates and the blocking signal is active, a BLOCKED signal is generated, and the function does not process the event further.
- When a START signal is already active and the blocking input signal becomes active, the START signal is reset and BLOCKED signal is generated. The release time characteristics are then processed in the same way as when the pick-up signal is reset.

The blocking signal needs to reach the device minimum of 5 ms before the set operating delay has passed in order for the blocking to activate in time.

The function also offers an optional internal inrush harmonic blocking feature. If the inrush harmonic pick-up is active at the same time as the protection function pick-up element, the trip delay timer continues counting down as normal. Once the countdown reaches zero, if the pick-up element remains active and the second harmonic value has dropped, the function issues a trip.

Table. 4.4.3 - 66. Internal inrush harmonic blocking settings.

| Name  | Range   | Step             | Default  | Description   |
|---|---|------------------|--|---|
| Inrush harmonic blocking (internal-only trip)                   | <ul style="list-style-type: none"> <li>• No</li> <li>• Yes</li> </ul> | -                | <ul style="list-style-type: none"> <li>• No</li> </ul> | Enables and disables the 2 <sup>nd</sup> harmonic blocking. |
| 2 <sup>nd</sup> harmonic blocking limit ( $I_{harm}/I_{fund}$ ) | 0.10...50.00% $I_{fund}$  | 0.01% $I_{fund}$ | 0.01% $I_{fund}$                                       | Defines the limit of the 2 <sup>nd</sup> harmonic blocking. |

## Operating time characteristics for trip and reset

This function supports definite time delay (DT) and inverse definite minimum time delay (IDMT). For detailed information on these delay types please refer to the chapter "[General properties of a protection function](#)" and its section "[Operating time characteristics](#)".

## Events and registers

The non-directional earth fault function (abbreviated "NEF" in event block names) generates events and registers from the status changes in the events listed below. The user can select which event messages are stored in the main event buffer: ON, OFF, or both. The events triggered by the function are recorded with a time stamp.

The function's outputs can be used for direct I/O controlling and user logic programming. The function also provides a resettable cumulative counter for the START, TRIP and BLOCKED events.

The function offers four (4) independent stages; the events are segregated for each stage operation.

Table. 4.4.3 - 67. Event messages.

| Event block name | Event names  |
|------------------|--------------|
| NEF1...NEF4      | Start ON/OFF |
| NEF1...NEF4      | Trip ON/OFF  |
| NEF1...NEF4      | Block ON/OFF |

The function registers its operation into the last twelve (12) time-stamped registers. The register of the function records the ON event process data for START, TRIP or BLOCKED. The table below presents the structure of the function's register content.

Table. 4.4.3 - 68. Register content.

| Name                 | Description                 |
|----------------------|-----------------------------|
| Date and time        | dd.mm.yyyy hh:mm:ss.mss     |
| Event                | Event name                  |
| Fault type           | A-G-R...C-G-F               |
| Pre-trigger current  | Start/Trip -20ms current    |
| Fault current        | Start/Trip current          |
| Pre-fault current    | Start -200ms current        |
| Trip time remaining  | 0 ms...1800s                |
| Setting group in use | Setting group 1...8 active. |

#### 4.4.4 Directional overcurrent protection (Idir>; 67)

The directional overcurrent function is used for instant and time-delayed overcurrent and short-circuits. A device with both voltage and current protection modules can have four (4) available stages of the function (Idir>, Idir>>, Idir>>>, Idir>>>>). The operating decisions are based on phase current magnitudes which the function constantly measures.

Figure. 4.4.4 - 31. Simplified function block diagram of the Idir> function.

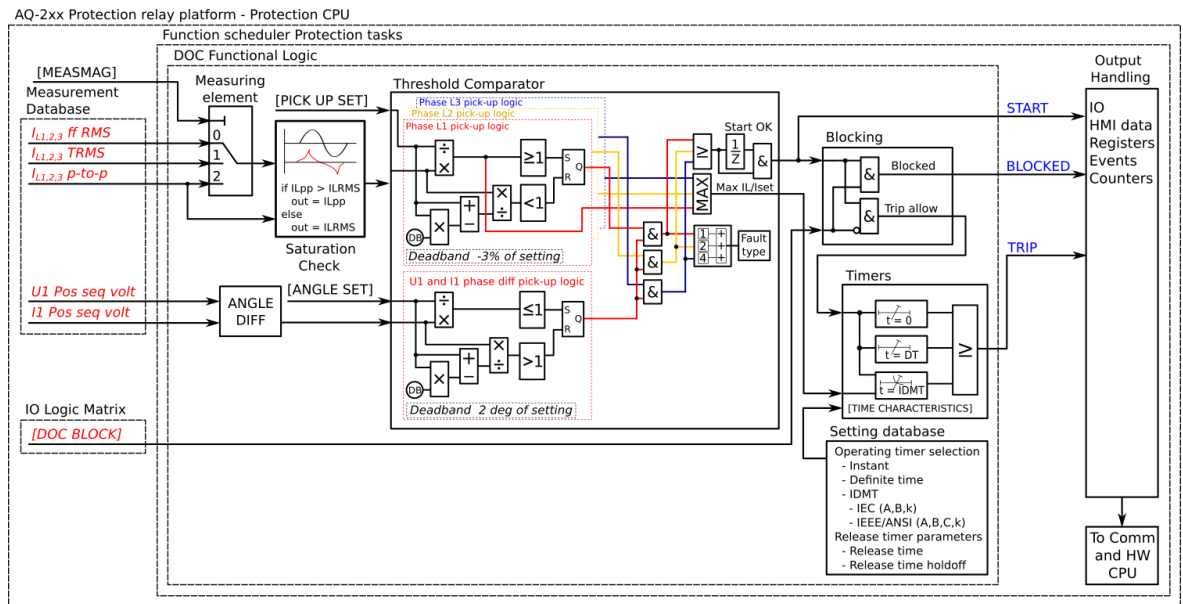

### Measured input

The function block uses phase current and voltage measurement values. The user can select the monitored current magnitude to be equal either to RMS values (fundamental frequency component), to TRMS values from the whole harmonic specter of 32 components, or to peak-to-peak values.

The fault current angle is based on the comparison between the positive sequence voltage  $U_1$  and the positive sequence current  $I_1$ . If the positive sequence voltage is not available (three line-to-line voltages but no  $U_0$ ), the voltage angle is based on a faulty phase line-to-line voltage. If the voltage drops below 1 V in the secondary side during a fault, the voltage memory is used for 0.5 seconds. After that the reference angle of voltage is forced to 0°.

Table. 4.4.4 - 69. Measurement inputs of the Idir> function.

| Signal       | Description   |
|--------------|---|
| $I_{L1}RMS$  | Fundamental frequency component of phase L1 (A) current measurement |
| $I_{L2}RMS$  | Fundamental frequency component of phase L2 (B) current measurement |
| $I_{L3}RMS$  | Fundamental frequency component of phase L3 (C) current measurement |
| $I_{L1}TRMS$ | TRMS measurement of phase L1 (A) current                            |
| $I_{L2}TRMS$ | TRMS measurement of phase L2 (B) current                            |
| $I_{L3}TRMS$ | TRMS measurement of phase L3 (C) current                            |
| $I_{L1}PP$   | Peak-to-peak measurement of phase L1 (A) current                    |
| $I_{L2}PP$   | Peak-to-peak measurement of phase L2 (B) current                    |
| $I_{L3}PP$   | Peak-to-peak measurement of phase L3 (C) current                    |
| $U_1RMS$     | Fundamental frequency component of $U_1/V$ voltage measurement      |
| $U_2RMS$     | Fundamental frequency component of $U_2/V$ voltage measurement      |

| Signal             | Description  |
|--------------------|--|
| U <sub>3</sub> RMS | Fundamental frequency component of U <sub>3</sub> /V voltage measurement |
| U <sub>4</sub> RMS | Fundamental frequency component of U <sub>4</sub> /V voltage measurement |

## General settings

The following general settings define the general behavior of the function. These settings are static i.e. it is not possible to change them by editing the setting group.

Table. 4.4.4 - 70. General settings of the function.

| Name                  | Range  | Default | Description  |
|-----------------------|--|---------|--|
| Idir> LN mode         | <ul style="list-style-type: none"> <li>• On</li> <li>• Blocked</li> <li>• Test</li> <li>• Test/Blocked</li> <li>• Off</li> </ul> | On      | Set mode of DOC block. This parameter is visible only when <i>Allow setting of individual LN mode</i> is enabled in <i>General</i> menu. |
| Idir> force status to | <ul style="list-style-type: none"> <li>• Normal</li> <li>• Start</li> <li>• Trip</li> <li>• Blocked</li> </ul>                   | Normal  | Force the status of the function. Visible only when <i>Enable stage forcing</i> parameter is enabled in <i>General</i> menu.             |
| Measured magnitude    | <ul style="list-style-type: none"> <li>• RMS</li> <li>• TRMS</li> <li>• Peak-to-peak</li> </ul>                                  | RMS     | Defines which available measured magnitude is used by the function.  |
| Measurement side      | <ul style="list-style-type: none"> <li>• Side 1</li> <li>• Side 2</li> </ul>   | Side 1  | Defines which current measurement module is used by the function. Visible if the unit has more than one current measurement module.      |

## Pick-up settings

The  $I_{set}$  setting parameter controls the pick-up of the I> function. This defines the maximum allowed measured current before action from the function. The function constantly calculates the ratio between the  $I_{set}$  and the measured magnitude ( $I_m$ ) for each of the three phases. The reset ratio of 97 % is built into the function and is always relative to the  $I_{set}$  value. The setting value is common for all measured phases, and when the  $I_m$  exceeds the  $I_{set}$  value (in single, dual or all phases) it triggers the pick-up operation of the function.

The trip characteristic can be set to directional or non-directional. In the non-directional mode only the pick-up value of the positive sequence current magnitude must be fulfilled in order for the function to trip. In the directional mode the fault must also be in the monitored direction to fulfill the terms to trip. By default, the tripping area is  $\pm 88^\circ$  ( $176^\circ$ ). The reference angle is based on the calculated positive sequence voltage  $U_1$  angle. If the  $U_1$  voltage is not available and only line-to-line voltages are measured, the reference angle is based on a healthy line-to-line voltage. During a short-circuit the reference angle is based on impedance calculation.

If the voltage drops below 1 V in the secondary side, the angle memory is used for 0.5 seconds. The angle memory forces the reference angle to be equal to the value measured or calculated before the fault. The angle memory captures the measured voltage angle 100 ms before the fault starts. After 0.5 seconds the angle memory is no longer used, and the reference angle is forced to  $0^\circ$ . The inbuilt reset ratio for the tripping area angle is  $2^\circ$ .

Setting group selection controls the operating characteristics of the function, i.e. the user or user-defined logic can change function parameters while the function is running.

Table. 4.4.4 - 71. Pick-up settings.

| Name                          | Range  | Step              | Default           | Description  |
|-------------------------------|--|-------------------|-------------------|--|
| Characteristic direction      | <ul style="list-style-type: none"> <li>Directional</li> <li>Non-directional</li> </ul> | -                 | Directional       | Switches between directional and non-directional overcurrent mode. |
| Operating sector size (+ / -) | $\pm 1.0 \dots 170.0^\circ$  | $0.1^\circ$       | $\pm 88^\circ$    | Pick-up area size in degrees.                                      |
| Operating sector center       | $-180.0 \dots 180.0^\circ$   | $0.1^\circ$       | $0^\circ$         | Turns the operating sector   |
| Pick-up setting $I_{set}$     | $0.10 \dots 40.00 \times I_n$  | $0.01 \times I_n$ | $1.20 \times I_n$ | Pick-up setting  |

Figure. 4.4.4 - 32. Angle tracking of the  $I_{dir} >$  function (3LN/3LL +  $U_0$  mode).

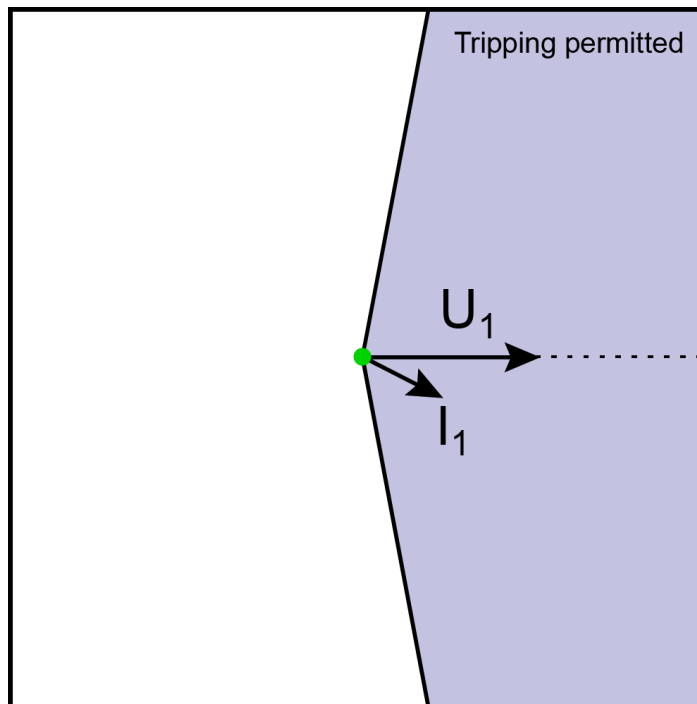

Please note in the picture above that the tripping area is linked to the angle of the positive sequence voltage  $U_1$ . The angle of the positive sequence current  $I_1$  is compared to  $U_1$  angle, and if the fault is in the correct direction, it is possible to perform a trip when the amplitude of  $I_{L1}$ ,  $I_{L2}$  or  $I_{L3}$  increases above the pick-up limit.

If the 3LL mode is used without the  $U_0$  measurement in a single-phase fault situation, the voltage reference comes from the healthy phase and the current reference from the faulty phase. In a short-circuit the angle comes from impedance calculation.

Figure. 4.4.4 - 33. Operation sector area when the sector center has been set to -45 degrees.

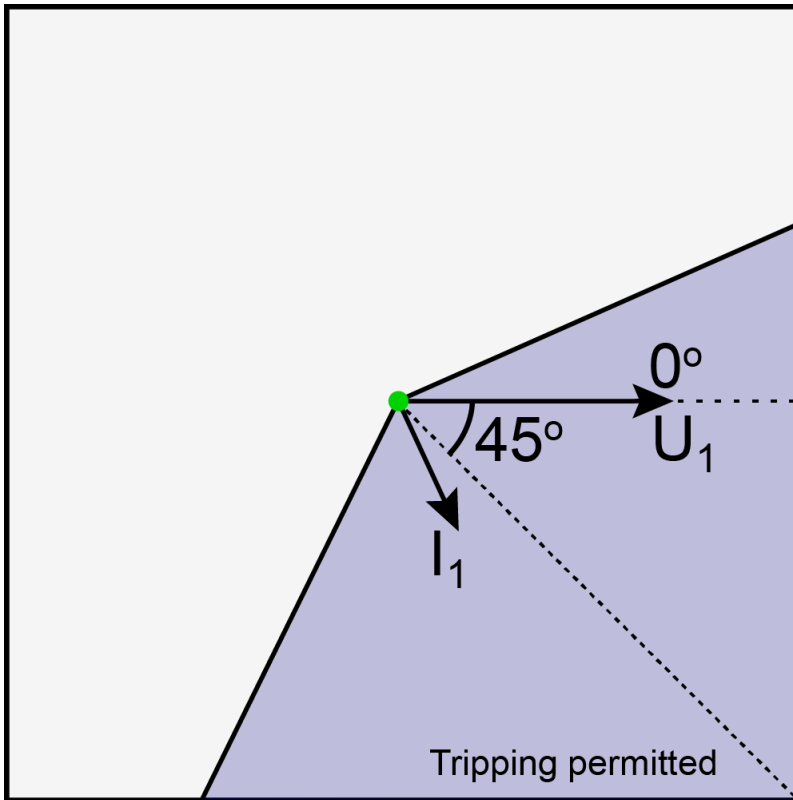
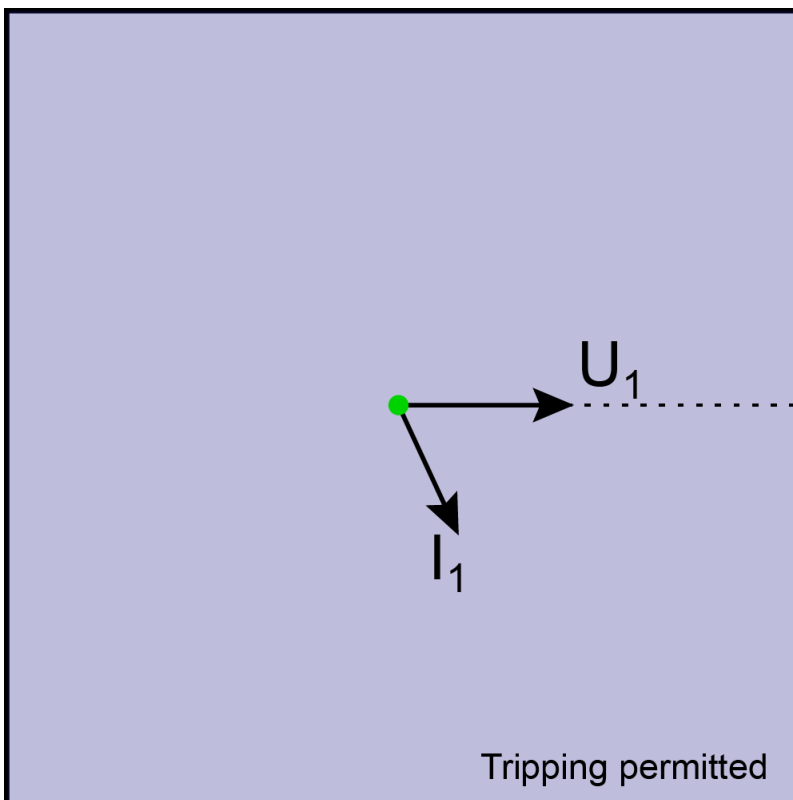

Figure. 4.4.4 - 34. When  $I_{dir}$  function has been set to "Non-directional" the function works basically just like a traditional non-directional overcurrent protection function.



## Read-only parameters

The function's *Info* page displays useful, real-time information on the state of the protection function. It is accessed either through the device's HMI display, or through the setting tool software when it is connected to the device and its Live Edit mode is active.

Table. 4.4.4 - 72. Information displayed by the function.

| Name  | Range  | Step                                 | Description   |
|---|--|--------------------------------------|---|
| Idir> LN behaviour                                | <ul style="list-style-type: none"> <li>• On</li> <li>• Blocked</li> <li>• Test</li> <li>• Test/Blocked</li> <li>• Off</li> </ul> | -                                    | Displays the mode of DOC block.<br>This parameter is visible only when <i>Allow setting of individual LN mode</i> is enabled in <i>General</i> menu.  |
| Operating angle now                               | -360.00...360.00deg  | 0.01deg                              | The positive sequence current angle in relation to the positive sequence voltage.   |
| Expected operating time                           | 0.000...1800.00s   | 0.005s                               | Displays the expected operating time when a fault occurs. When IDMT mode is used, the expected operating time depends on the highest measured phase current value. If the measured current changes during a fault, the expected operating time changes accordingly. |
| Time remaining to trip                            | -1800.000...1800.00s   | 0.005s                               | When the function has detected a fault and counts down time towards a trip, this displays how much time is left before tripping occurs.   |
| I <sub>meas</sub> /I <sub>set</sub> at the moment | 0.00...1250.00I <sub>m</sub> /I <sub>set</sub>   | 0.01I <sub>m</sub> /I <sub>set</sub> | The ratio between the highest measured phase current and the pick-up value.   |

## Function blocking

The blocking signal is evaluated at the start of each program cycle. The blocking signals are connected to the function's dedicated input, which can be configured in the *IO* → *Blocking Input Control* tab of the function.

- When the pick-up element activates and the blocking signal is not active, a START signal is generated, and the function starts or continues with the trip time countdown.
- When the pick-up element activates and the blocking signal is active, a BLOCKED signal is generated, and the function does not process the event further.
- When a START signal is already active and the blocking input signal becomes active, the START signal is reset and BLOCKED signal is generated. The release time characteristics are then processed in the same way as when the pick-up signal is reset.

The blocking signal needs to reach the device minimum of 5 ms before the set operating delay has passed in order for the blocking to activate in time.

The function also offers an optional internal inrush harmonic blocking feature. If the inrush harmonic pick-up is active at the same time as the protection function pick-up element, the trip delay timer continues counting down as normal. Once the countdown reaches zero, if the pick-up element remains active and the second harmonic value has dropped, the function issues a trip.

Table. 4.4.4 - 73. Internal inrush harmonic blocking settings.

| Name  | Range   | Step                   | Default  | Description   |
|---|---|------------------------|--|---|
| Inrush harmonic blocking (internal-only trip)                                   | <ul style="list-style-type: none"> <li>No</li> <li>Yes</li> </ul> | -                      | <ul style="list-style-type: none"> <li>No</li> </ul> | Enables and disables the 2 <sup>nd</sup> harmonic blocking. |
| 2 <sup>nd</sup> harmonic blocking limit (I <sub>harm</sub> /I <sub>fund</sub> ) | 0.10...50.00%I <sub>fund</sub>                                    | 0.01%I <sub>fund</sub> | 0.01%I <sub>fund</sub>                               | Defines the limit of the 2 <sup>nd</sup> harmonic blocking. |

## Operating time characteristics for trip and reset

This function supports definite time delay (DT) and inverse definite minimum time delay (IDMT). For detailed information on these delay types please refer to the chapter "[General properties of a protection function](#)" and its section "[Operating time characteristics](#)".

## Events and registers

The directional overcurrent function (abbreviated "DOC" in event block names) generates events and registers from the status changes in the events listed below. The user can select which event messages are stored in the main event buffer: ON, OFF, or both. The events triggered by the function are recorded with a time stamp.

The function's outputs can be used for direct I/O controlling and user logic programming. The function also provides a resettable cumulative counter for the START, TRIP and BLOCKED events.

The function offers four (4) independent stages; the events are segregated for each stage operation.

Table. 4.4.4 - 74. Event messages.

| Event block name | Event names                 |
|------------------|-----------------------------|
| DOC1...DOC4      | Start ON/OFF                |
| DOC1...DOC4      | Trip ON/OFF                 |
| DOC1...DOC4      | Block ON/OFF                |
| DOC1...DOC4      | No voltage, Blocking ON/OFF |
| DOC1...DOC4      | Measuring live angle ON/OFF |
| DOC1...DOC4      | Using voltmem ON/OFF        |

The function registers its operation into the last twelve (12) time-stamped registers; this information is available for all provided instances separately. The register of the function records the ON event process data for START, TRIP or BLOCKED. The table below presents the structure of the function's register content.

Table. 4.4.4 - 75. Register content.

| Register name | Description             |
|---------------|-------------------------|
| Date and time | dd.mm.yyyy hh:mm:ss.mss |
| Event         | Event name              |

| Register name        | Description                |
|----------------------|----------------------------|
| Fault type           | L1-E...L1-L2-L3            |
| Pre-trigger current  | Start/Trip -20ms current   |
| Fault current        | Start/Trip current         |
| Pre-fault current    | Start -200ms averages      |
| Trip time remaining  | 0s...1800s                 |
| Setting group in use | Setting group 1...8 active |
| Operating angle      | 0...250°                   |

### 4.4.5 Directional earth fault protection (I0dir>; 67N/32N)

The directional earth fault function is used for instant and time-delayed earth fault protection. A device with both voltage and current protection modules can have four (4) stages in the function (I0dir>, I0dir>>, I0dir>>>, I0dir>>>>). The operating decisions are based on selected neutral current and voltage magnitudes which the function constantly measures.

Figure. 4.4.5 - 35. Simplified function block diagram of the I0dir> function.

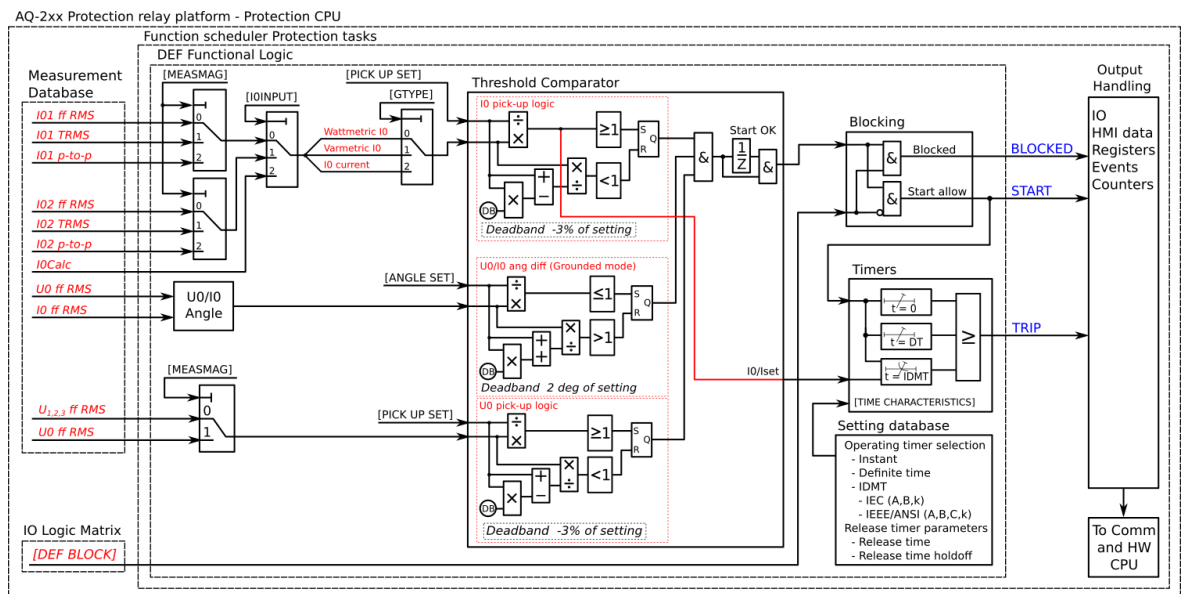

### Measured input

The function block uses residual current measurement values and neutral voltage measurement values. The available residual current measurement channels are I01 and I02 (residual current measurement) and IOCalc (residual current calculated from phase current). The user can select the monitored current magnitude to be equal either to RMS values (fundamental frequency component), to TRMS values from the whole harmonic spectrum of 32 components, or to peak-to-peak values.

The fault current angle is based on comparing the neutral voltage U0 angle to the residual current I0 angle. Both I0 and U0 must be above the squelch limit to be able to detect the angle. The squelch limit for the I0 current is 0.01 x In and for the U0 voltage 0.01 x Un.

Table. 4.4.5 - 76. Measurement inputs of the I0dir> function.

| Signal  | Description  |
|---------|--|
| I01RMS  | Fundamental frequency component of coarse residual current measurement input I01                         |
| I01TRMS | TRMS measurement of coarse residual current measurement input I01  |
| I01PP   | Peak-to-peak measurement of coarse residual current measurement input I01                                |
| I02RMS  | Fundamental frequency component of sensitive residual current measurement input I02                      |
| I02TRMS | TRMS measurement of coarse sensitive current measurement input I02                                       |
| I02PP   | Peak-to-peak measurement of sensitive residual current measurement input I02                             |
| I0Calc  | Fundamental frequency component of residual current calculated from the three phase currents             |
| U0RMS   | Fundamental frequency component of zero sequence voltage measurement input U0                            |
| U0Calc  | Fundamental frequency component of of the zero sequence voltage calculated from the three phase voltages |

## General settings

The following general settings define the general behavior of the function. These settings are static i.e. it is not possible to change them by editing the setting group.

Table. 4.4.5 - 77. General settings of the function.

| Name                     | Range  | Default | Description  |
|--------------------------|--|---------|--|
| I0dir> LN mode           | On<br>Blocked<br>Test<br>Test/Blocked<br>Off   | On      | Set mode of DEF block.<br>This parameter is visible only when <i>Allow setting of individual LN mode</i> is enabled in <i>General</i> menu.  |
| I0dir> force status to   | <ul style="list-style-type: none"> <li>• Normal</li> <li>• Start</li> <li>• Trip</li> <li>• Blocked</li> <li>• Uearthed Start</li> <li>• Uearthed Trip</li> <li>• Compensated Start</li> <li>• Compensated Trip</li> </ul> | Normal  | Force the status of the function. Visible only when <i>Enable stage forcing</i> parameter is enabled in <i>General</i> menu.   |
| U0 directional reference | <ul style="list-style-type: none"> <li>• U0</li> <li>• -U0</li> </ul>  | U0      | If the connected neutral voltage polarity is opposite to the connected residual current, this parameter can swap the angle reference.  |
| U0> Meas input select    | <ul style="list-style-type: none"> <li>• Select</li> <li>• U0 Calculated</li> <li>• U3 Input</li> <li>• U4 Input</li> </ul>  | Select  | Defines which available neutral voltage measurement is used. Available neutral voltages depend on measurement settings ( <i>Measurements</i> → <i>Transformers</i> → <i>VT module</i> ). |

| Name               | Range   | Default | Description  |
|--------------------|---|---------|--|
| Measured magnitude | <ul style="list-style-type: none"> <li>RMS</li> <li>TRMS</li> <li>Peak-to-peak</li> </ul> | RMS     | Defines which available measured magnitude is used by the function. This parameter is available when "Input selection" has been set to "I01" or "I02". |
| Measurement side   | <ul style="list-style-type: none"> <li>Side 1</li> <li>Side 2</li> </ul>                  | Side 1  | Defines which current measurement module is used by the function.  |
| Input selection    | <ul style="list-style-type: none"> <li>I01</li> <li>I02</li> <li>I0Calc</li> </ul>        | I01     | Defines which measured residual current is used by the function.   |

### Pick-up settings

The the pick-up of the  $I0dir$  function is controlled by the  $I0_{set}$  setting parameter and the  $U0_{set}$  setting parameter. The former defines the maximum allowed measured current, while the latter defines the maximum allowed measured voltage and checks the angle difference before action from the function. The function constantly calculates the ratio between the  $I0_{set}$  and the  $U0_{set}$  and the measured magnitudes ( $I_m$  and  $U_m$ ). The reset ratio of 97 % is built into the function and is always relative to the  $I0_{set}$  (or  $U0_{set}$ ) value. When the  $I_m$  exceeds the  $I0_{set}$  value it triggers the pick-up operation of the function.

Setting group selection controls the operating characteristics of the function, i.e. the user or user-defined logic can change function parameters while the function is running.

Table. 4.4.5 - 78. Pick-up settings.

| Name  | Range  | Step         | Default     | Description   |
|---|--|--------------|-------------|---|
| Grounding type  | <ul style="list-style-type: none"> <li>Unearthed [32N Var]</li> <li>Petersen coil GND [32N Watt]</li> <li>Grounded [67N]</li> <li><math>I0_{Cos}</math> &amp; <math>I0_{Sin}</math> broad range with MCD [32N Var/Watt]</li> </ul> | -            | Unearthed   | Network grounding method  |
| Pick-up setting $I0_{set}$ >                          | 0.005...40.00× $I_n$   | 0.001× $I_n$ | 1.20× $I_n$ | Current pick-up setting. If broadrange mode is selected, unearthed and compensated networks have separate pick-up settings. |
| Comp. pick-up setting $I0_{set}$ ( $I0_{Cosfi}$ )>    |  |              |             |   |
| Unearth. pick-up setting $I0_{set}$ ( $I0_{Sinfi}$ )> |  |              |             |   |
| Pick-up setting $U0_{set}$ >                          | 1...75% $U_n$  | 0.01% $U_n$  | 20% $U_n$   | Voltage pick-up setting. If broadrange mode is selected, unearthed and compensated networks have separate pick-up settings. |

| Name  | Range  | Step | Default  | Description  |
|---|--|------|----------|--|
| Comp. pick-up setting<br>$U_{0set} (I_{0Cosfi}) >$    |  |      |          |  |
| Unearth. pick-up setting<br>$U_{0set} (I_{0Sinfi}) >$ |  |      |          |  |
| Multi-criteria detection                              | <ul style="list-style-type: none"> <li>Not used</li> <li>Used</li> </ul> | -    | Not used | Activation of detecting healthy or unhealthy feeder by analyzing symmetrical components of currents and voltages. Visible when broadrange mode is used.                                |
| Unearthed/Compensated border angle                    | -45.0...90°  | 0.1° | 45°      | Dividing the angle between unearthed and compensated tripping (see description later in this document). Visible when earthing type is set to $I_{0Cos}$ & $I_{0Sin}$ broad range mode. |
| Resistive ( $I_{0Cosfi}$ ) mode $I_0$ angle blinder.  | -90.0...0.0°   | 0.1° | -90°     | $I_0$ angle blinder. Used in broadrange and Petersen coil grounded mode. Not in use when set to zero.  |
| Tripping area size (+ / -)                            | ±45.0...135.0°   | 0.1° | ±88°     | Defines the tripping area sector size in grounded network mode.  |
| Tripping area center                                  | -360.00...360.00   | 0.1° | 0.0°     | Turns the tripping area in grounded network mode.  |

## Unearthed network

Figure. 4.4.5 - 36. Angle tracking of  $I_{0dir}$  function (unearthed network model) (32N)

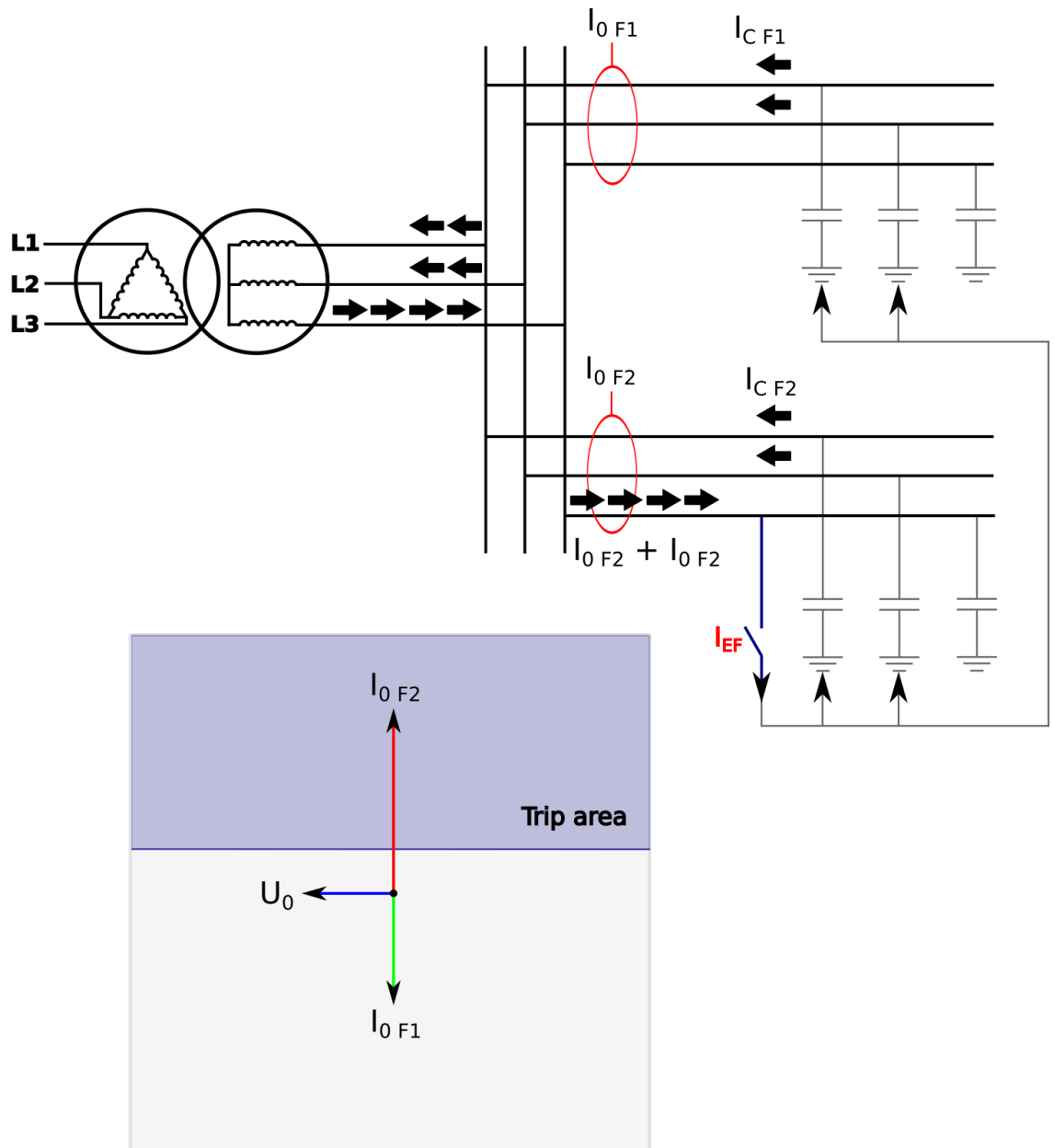

When the unearthed (capacitive) network mode is chosen, the function expects the fault current to be lagging zero sequence voltage by 90 degrees. Healthy phases of healthy feeders produce capacitive current during earth fault just like a faulty feeder but the current is floating towards the busbar and through an incoming feeder transformer or a earthing transformer and into a faulty feeder. Healthy feeders do not trip since capacitive current is floating to the opposite direction and selective tripping can be ensured.

The amplitude of the fault current depends on the capacitance of the network. The outgoing feeders are the sources for capacitive currents. The bigger the network the greater the capacitive current during a fault. Each outgoing feeder produces capacitance according to the zero sequence capacitive reactance of the line (ohms per kilometer). It is normal that in cable networks fault currents are higher than in overhead lines.

The resistance of the fault affects the size of the voltage drop during a fault. In direct earth fault the zero sequence voltage amplitude is equal to the system's line-to-earth voltage. In direct earth fault the voltage of a faulty phase drops close to zero and healthy phase voltages increase to the amplitude of line-to-line voltages.

### Petersen coil earthed (Compensated) network (32N)

There are many benefits to a Petersen coil earthed network. The amount of automatic reclosing is highly decreased and the maintenance of the breakers is therefore diminished. Arc faults die on their own, and cables and equipment suffer less damage. In emergency situations a line with an earth fault can be used for a specific time.

Figure. 4.4.5 - 37. Angle tracking of  $I_{0dir}$  function (Petersen coil earthed network model).

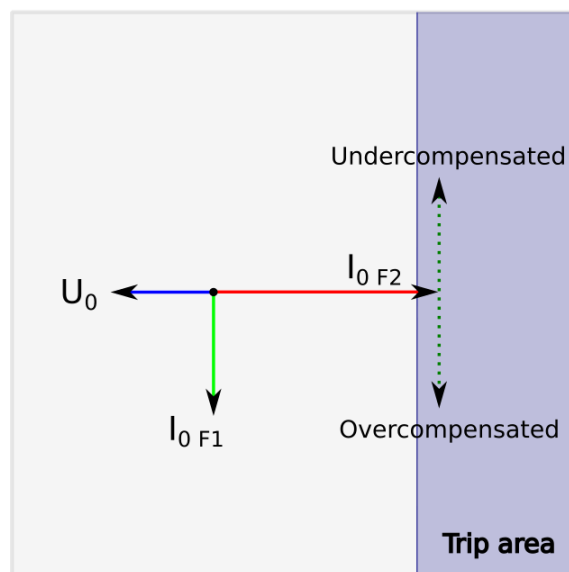
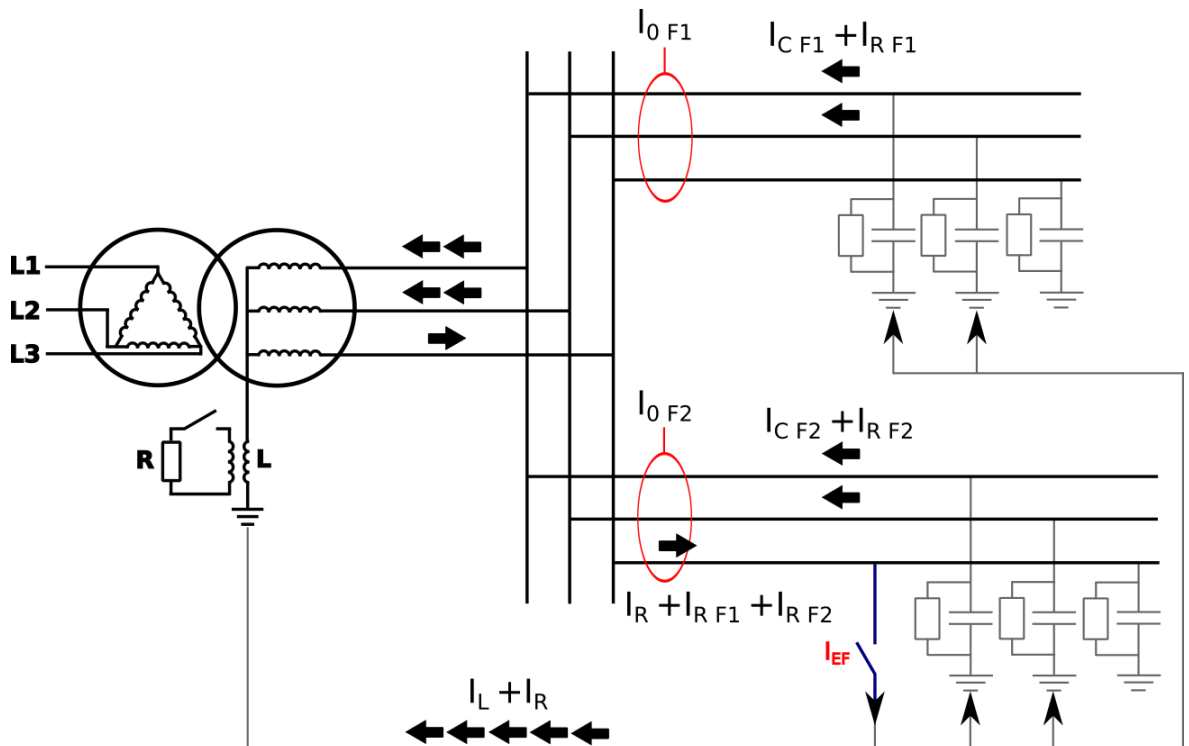

When the Petersen coil earthed (compensated) network mode is chosen, the function expects the fault current to be in the opposite direction to the zero sequence voltage. Healthy phases of both healthy and faulty feeders produce a capacitive current similar to the unearthed network. The inductance of the Petersen coil compensates the capacitive current and therefore the residual current in a fault location is close to zero. The size of the inductance is chosen according to the prospective earth fault current of the network. The desired compensation grade is achieved when the K factor is close to 1.0 and the network is fully compensated. The network is overcompensated when the K factor is greater than 1.0, and undercompensated when the K factor is smaller than 1.0.

The inductance connected to the star point of an incoming feeder transformer or -as in most cases- to a earthing transformer compensates the capacitance of the network; however, this prevents the capacitive fault current to be measured. The fault detection is handled by connecting the resistance in parallel with the inductance. This resistance includes the amplitude of the fault current. In undercompensated or overcompensated situations the resistive component does not change during the fault; therefore, selective tripping is ensured even when the network is slightly undercompensated or overcompensated.

### Directly earthed or small impedance network (67N)

Figure. 4.4.5 - 38. Angle tracking of  $I_{0dir}$  function (directly earthed or small impedance network).

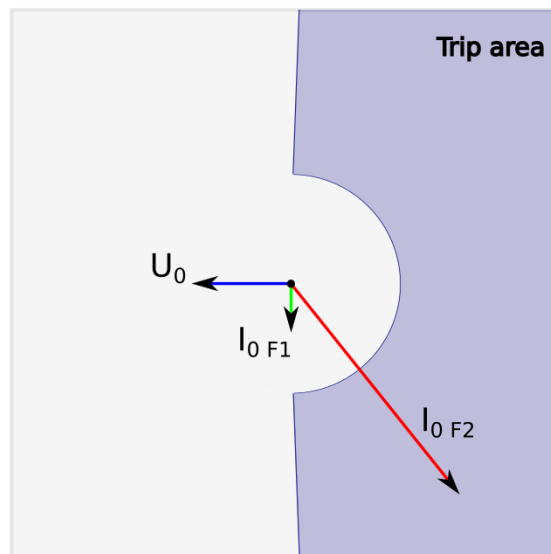
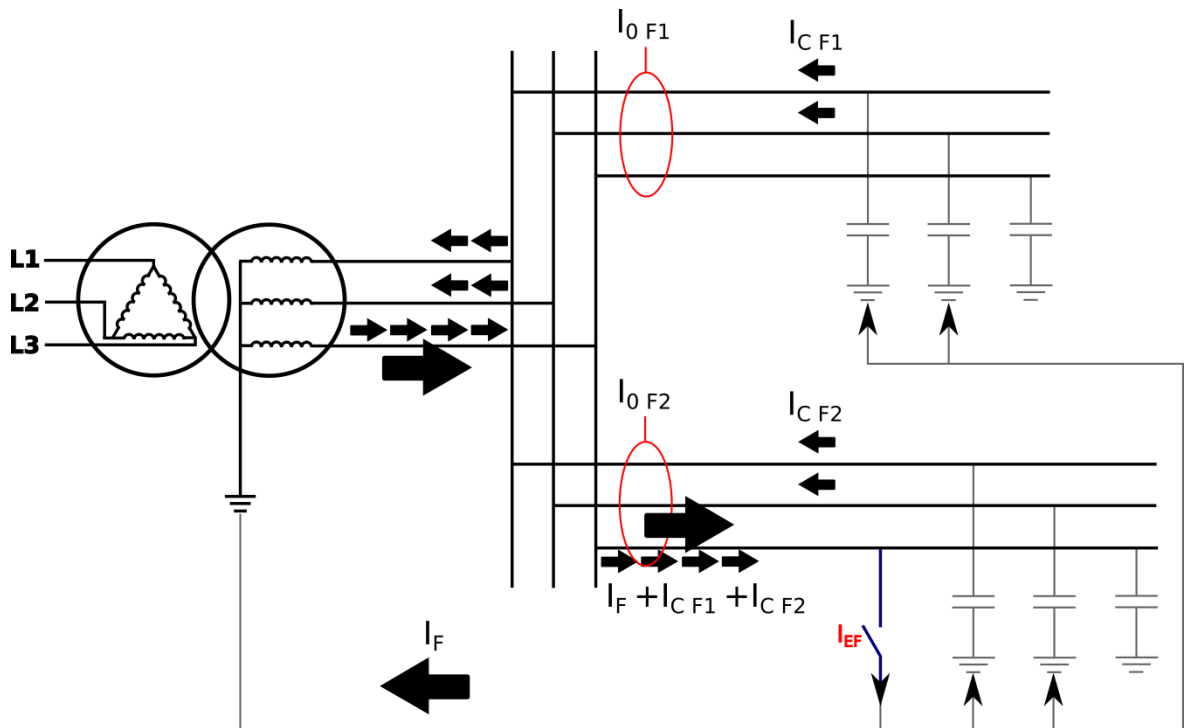

In a directly earthed network the amplitude of a single-phase fault current is similar to the amplitude of a short-circuit current. Directly earthed or small impedance network schemes are normal in transmission, distribution and industry.

The phase angle setting of the tripping area is adjustable as is the base direction of the area (angle offset).

## Broad range mode with multi-criteria detection for unearthed and compensated networks

When detecting earth faults in compensated long-distance cables and overhead lines, it is in some cases difficult to distinguish between a healthy and a faulty feeder. Merely measuring the angle and the magnitude of residual voltage and currents is not always enough, as changes in symmetrical components of phase currents and voltages are also needed. Additionally, when protecting feeders from earth faults, two modes are used depending on the network status (unearthed or compensated). When changing between these two statuses the setting group must be changed, and especially with distributed compensation the change may be difficult or impossible to arrange. Finally, in a compensated network protection relays with traditional algorithms may sporadically detect an earth fault in a long healthy feeder due to CT errors. For all these reasons, Arcteq has developed an improved alternative to these traditional directional earth fault protections.

Figure. 4.4.5 - 39. Angle tracking of the I0dir> function (broad range mode).

### New broadrange mode

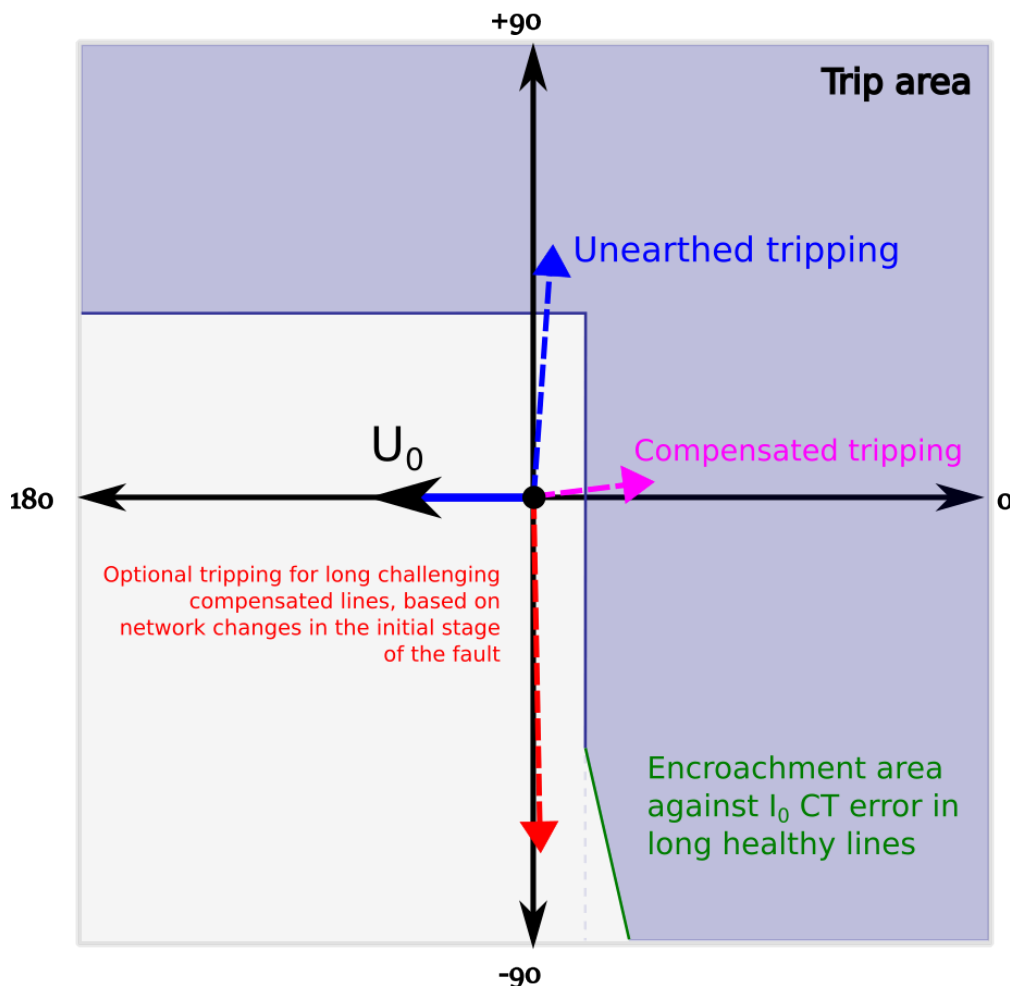

The new broad range mode is capable of detecting an earth fault directionally in both unearthed and compensated networks not only by combining the two stages together but by using a new multi-criteria detection. This optional additional tripping condition for compensated networks uses Arcteq's patented, high-resolution intermittent earth fault algorithm with added symmetrical component calculation of phase currents and voltages. If this mode is activated, the alarming criteria is comprised of a measured residual current in the fourth quadrant and the symmetrical components of voltages and currents detecting a fault. No extra parameterization is required compared to the traditional method. The multi-criteria algorithm can be tested with COMTRADE files supplied by Arcteq. The function requires a connection of three-phase currents, residual current and residual voltage to operate correctly.

To avoid unnecessary alarms the user can add an encroachment area against IO CT errors in compensated long healthy lines.

Figure. 4.4.5 - 40. Effect of angle divider when in use and when disabled.

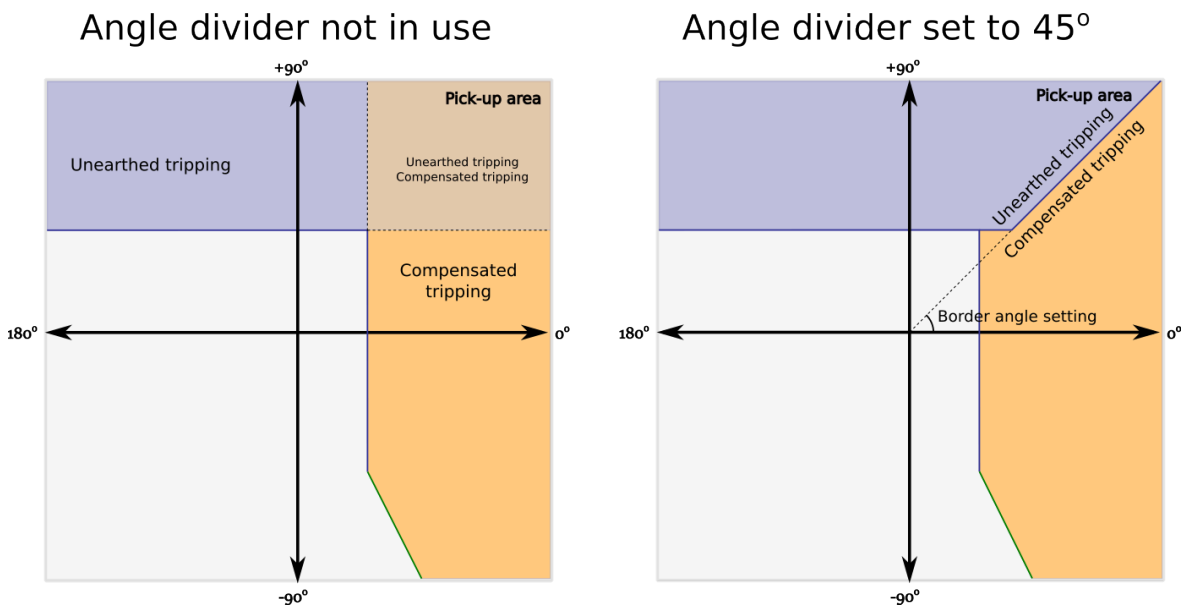

To receive a more accurate indication as to whether the fault was in a compensated or an unearthed network the angle divider can divide the area which would otherwise be overlapped between the two network models. By default the setting is 45 degrees. When the divider is disabled the angle is set to zero degrees.

### Read-only parameters

The function's *Info* page displays useful, real-time information on the state of the protection function. It is accessed either through the device's HMI display, or through the setting tool software when it is connected to the device and its Live Edit mode is active.

Table. 4.4.5 - 79. Information displayed by the function.

| Name                | Range  | Step | Description   |
|---------------------|--|------|---|
| I0dir> LN behaviour | <ul style="list-style-type: none"> <li>• On</li> <li>• Blocked</li> <li>• Test</li> <li>• Test/Blocked</li> <li>• Off</li> </ul> | On   | Set mode of NOC block.<br>This parameter is visible only when <i>Allow setting of individual LN mode</i> is enabled in <i>General</i> menu. |

| Name                          | Range  | Step      | Description   |
|-------------------------------|--|-----------|---|
| I0dir><br>condition           | <ul style="list-style-type: none"> <li>• Normal</li> <li>• Start</li> <li>• Trip</li> <li>• Blocked</li> </ul>             | -         | Displays the status of the protection function.   |
| U0><br>Measuring<br>now       | <ul style="list-style-type: none"> <li>• No U0 avail!</li> <li>• U0Calc</li> <li>• U3 Input</li> <li>• U4 Input</li> </ul> | -         | Displays which voltage channel is used by the function. If no voltage channel has been selected the function defaults to calculated residual voltage if line-to-neutral voltages have been connected to device. If no channel is set to "U0" mode and line-to-line voltages are connected, no residual voltage is available and "No U0 avail!" will be displayed. |
| U0> Pick-up<br>setting        | 0.0...1 000 000V   | 0.1V      | The required residual voltage on the primary side for the function to trip.   |
| Detected U0/<br>I0 angle (fi) | -360.00...360.00deg  | 0.01deg   | The angle in degrees between the monitored residual voltage and the current.  |
| I0 Magnitude                  | 0.000...250.000×I0n  | 0.001×I0n | The per-unit-value of the monitored residual current.   |
| I0 Wattmetric<br>I0xCos(fi)   | -250.000...250.000×I0n   | 0.001×I0n | The wattmetric per-unit-value of the monitored residual current.  |
| I0 Varmetric<br>I0xSin(fi)    | -250.000...250.000×I0n   | 0.001×I0n | The varmetric per-unit-value of the monitored residual current.   |
| I0 direction<br>now           | <ul style="list-style-type: none"> <li>• Undefined</li> <li>• Forward</li> <li>• Reverse</li> </ul>                        | -         | The detected direction of the residual current.   |
| I0 meas/ I0<br>set now        | -250.000...250.000×I0n   | 0.001×I0n | The ratio between the monitored residual current and the pick-up value.   |
| U0<br>measurement<br>now      | 0.000...500.000%U0n  | 0.001%U0n | The measured voltage in the chosen voltage channel.   |
| Expected<br>operating<br>time | 0.000...1800.000s  | 0.005s    | Displays the expected operating time when a fault occurs. When IDMT mode is used, the expected operating time depends on the measured current value. If the measured current changes during a fault, the expected operating time changes accordingly.   |
| Time<br>remaining to<br>trip  | -1800.000...1800.000s  | 0.005s    | When the function has detected a fault and counts down time towards a trip, this displays how much time is left before tripping occurs.   |

## Function blocking

The blocking signal is evaluated at the start of each program cycle. The blocking signals are connected to the function's dedicated input, which can be configured in the *IO* → *Blocking Input Control* tab of the function.

- When the pick-up element activates and the blocking signal is not active, a START signal is generated, and the function starts or continues with the trip time countdown.
- When the pick-up element activates and the blocking signal is active, a BLOCKED signal is generated, and the function does not process the event further.

- When a START signal is already active and the blocking input signal becomes active, the START signal is reset and BLOCKED signal is generated. The release time characteristics are then processed in the same way as when the pick-up signal is reset.

The blocking signal needs to reach the device minimum of 5 ms before the set operating delay has passed in order for the blocking to activate in time.

The function also offers an optional internal inrush harmonic blocking feature. If the inrush harmonic pick-up is active at the same time as the protection function pick-up element, the trip delay timer continues counting down as normal. Once the countdown reaches zero, if the pick-up element remains active and the second harmonic value has dropped, the function issues a trip.

Table. 4.4.5 - 80. Internal inrush harmonic blocking settings.

| Name  | Range   | Step                   | Default  | Description   |
|---|---|------------------------|--|---|
| Inrush harmonic blocking (internal-only trip)                                   | <ul style="list-style-type: none"> <li>No</li> <li>Yes</li> </ul> | -                      | <ul style="list-style-type: none"> <li>No</li> </ul> | Enables and disables the 2 <sup>nd</sup> harmonic blocking. |
| 2 <sup>nd</sup> harmonic blocking limit (I <sub>harm</sub> /I <sub>fund</sub> ) | 0.10...50.00%I <sub>fund</sub>                                    | 0.01%I <sub>fund</sub> | 0.01%I <sub>fund</sub>                               | Defines the limit of the 2 <sup>nd</sup> harmonic blocking. |

## Operating time characteristics for trip and reset

This function supports definite time delay (DT) and inverse definite minimum time delay (IDMT). For detailed information on these delay types please refer to the chapter "[General properties of a protection function](#)" and its section "[Operating time characteristics](#)".



### NOTICE!

IDMT settings are not available in broadrange mode.

Table. 4.4.5 - 81. Time delay settings specific to the directional earth fault function.

| Name  | Range  | Step    | Default     | Description   |
|---|--|---------|-------------|---|
| Delay type of broad range characteristics   | <ul style="list-style-type: none"> <li>Common time</li> <li>Separate time for I<sub>OCosfi</sub> and I<sub>OSinfi</sub></li> </ul> | -       | Common time | If broadrange mode is selected, it is possible to set separate time delay for earth faults in grounded networks and Petersen coil compensated networks. |
| Definite operating time delay (Compensated) | 0.000...1800.000 s   | 0.005 s | 0.040 s     | Time delays for compensated and unearthed earth faults when "Delay type of broad range characteristics" has been set to "Separate".                     |
| Definite operating time delay (Unearthed)   |  |         |             |   |

## Events and registers

The directional overcurrent function (abbreviated "DEF" in event block names) generates events and registers from the status changes in the events listed below. The user can select which event messages are stored in the main event buffer: ON, OFF, or both. The events triggered by the function are recorded with a time stamp.

The function's outputs can be used for direct I/O controlling and user logic programming. The function also provides a cumulative counter for the START, TRIP and BLOCKED events.

The function offers four (4) independent stages; the events are segregated for each stage operation.

Table. 4.4.5 - 82. Event messages.

| Event block name | Event name           |
|------------------|----------------------|
| DEF1...DEF4      | Start ON/OFF         |
| DEF1...DEF4      | Trip ON/OFF          |
| DEF1...DEF4      | Block ON/OFF         |
| DEF1...DEF4      | I0Cosfi Start ON/OFF |
| DEF1...DEF4      | I0Sinfi Start ON/OFF |
| DEF1...DEF4      | I0Cosfi Trip ON/OFF  |
| DEF1...DEF4      | I0Sinfi Trip ON/OFF  |

The function registers its operation into the last twelve (12) time-stamped registers; this information is available for all provided instances separately. The register of the function records the ON event process data for START, TRIP or BLOCKED. The table below presents the structure of the function's register content.

Table. 4.4.5 - 83. Register content.

| Register                  | Description                                |
|---------------------------|--|
| Event                     | Event name                                 |
| Date and time             | dd.mm.yyyy hh:mm:ss.mss                    |
| I0 pre-triggering current | Start/Trip -20ms current                   |
| I0 fault current          | Start/Trip current                         |
| Fault capacitive I0       | Start/Trip capacitive current              |
| Fault resistive I0        | Start/Trip resistive current               |
| Fault U0 (%)              | Start/Trip voltage (percentage of nominal) |
| Fault U0 (V)              | Start/Trip voltage (in Volts)              |
| I0 fault angle            | 0...360°                                   |
| Trip time remaining       | 0 ms...1800s                               |

| Register                | Description                                       |
|-------------------------|---|
| Setting group in use    | Setting group 1...8 active                        |
| Network GND             | Unearthed, Petersen coil earthed, Earthed network |
| $I_0$ pre-fault current | Start -200ms current                              |

### 4.4.6 Negative sequence overcurrent/ phase current reversal/ current unbalance protection ( $I_2 >$ ; 46/46R/46L)

The current unbalance function is used for instant and time-delayed unbalanced network protection and for detecting broken conductors. The number of stages in the function depends on the device model. The operating decisions are based on negative and positive sequence current magnitudes which the function constantly measures. In the broken conductor mode ( $I_2/I_1$ ) the minimum allowed loading current is also monitored in the phase current magnitudes.

There are two possible operating modes available: the  $I_2$  mode monitors the negative sequence current, while the  $I_2/I_1$  mode monitors the ratio between the negative sequence current and the positive sequence current. The device calculates the symmetrical component magnitudes in use from the phase current inputs  $I_{L1}$ ,  $I_{L2}$  and  $I_{L3}$ . The zero sequence current is also recorded into the registers as well as the angles of the positive, negative and zero sequence currents in order to better verify any fault cases.

Figure. 4.4.6 - 41. Simplified function block diagram of the  $I_2 >$  function.

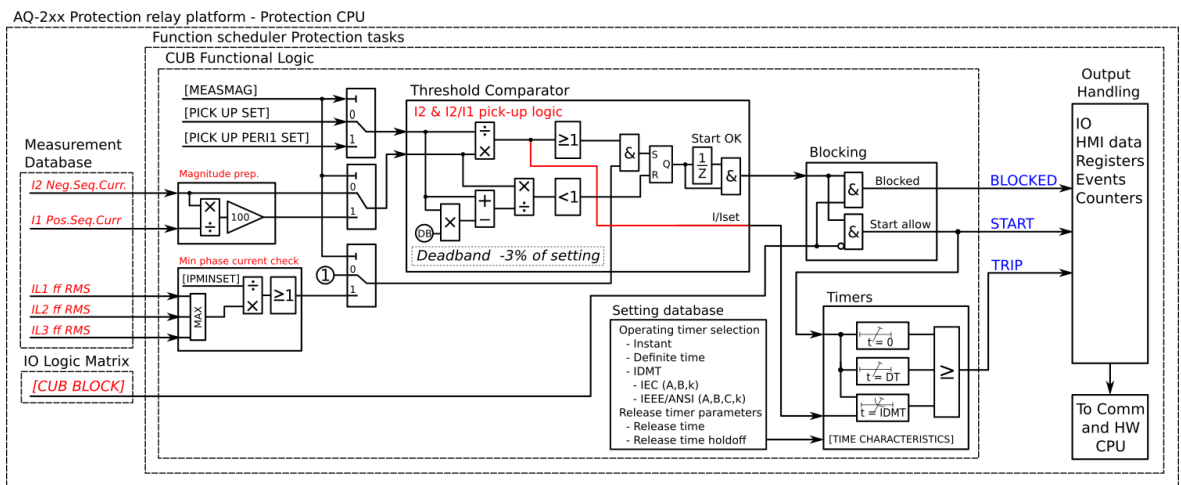

### Measured input

The function block uses positive and negative sequence currents calculated from the phase current measurement channels. In the broken conductor mode ( $I_2/I_1$ ) the function also uses fundamental frequency component of all phase currents to check the minimum current. Zero sequence and component sequence angles are used for fault registering and for fault analysis processing.

Table. 4.4.6 - 84. Measurement inputs of the  $I_2 >$  function.

| Signal | Description                         |
|--------|-------------------------------------|
| I1     | Positive sequence current magnitude |
| I2     | Negative sequence current magnitude |

| Signal              | Description   |
|---------------------|---|
| I <sub>Z</sub>      | Zero sequence current magnitude                                     |
| I <sub>1</sub> ANG  | Positive sequence current angle                                     |
| I <sub>2</sub> ANG  | Negative sequence current angle                                     |
| I <sub>Z</sub> ANG  | Zero sequence current angle   |
| I <sub>L1</sub> RMS | Fundamental frequency component of phase L1 (A) current measurement |
| I <sub>L2</sub> RMS | Fundamental frequency component of phase L2 (B) current measurement |
| I <sub>L3</sub> RMS | Fundamental frequency component of phase L3 (C) current measurement |

### General settings

The following general settings define the general behavior of the function. These settings are static i.e. it is not possible to change them by editing the setting group.

Table. 4.4.6 - 85. General settings of the function.

| Name                             | Range  | Default           | Description  |
|----------------------------------|--|-------------------|--|
| I <sub>2</sub> > LN mode         | <ul style="list-style-type: none"> <li>On</li> <li>Blocked</li> <li>Test</li> <li>Test/Blocked</li> <li>Off</li> </ul> | On                | Set mode of CUB block.<br>This parameter is visible only when <i>Allow setting of individual LN mode</i> is enabled in <i>General</i> menu.                            |
| I <sub>2</sub> > force status to | <ul style="list-style-type: none"> <li>Normal</li> <li>Start</li> <li>Trip</li> <li>Blocked</li> </ul>                 | Normal            | Force the status of the function. Visible only when <i>Enable stage forcing</i> parameter is enabled in <i>General</i> menu.   |
| Measurement side                 | <ul style="list-style-type: none"> <li>Side 1</li> <li>Side 2</li> </ul>   | Side 1            | Defines which current measurement module is used by the function. Visible if the unit has more than one current measurement module.                                    |
| Measured magnitude               | <ul style="list-style-type: none"> <li>I<sub>2</sub>pu</li> <li>I<sub>2</sub>/I<sub>1</sub></li> </ul>                 | I <sub>2</sub> pu | Defines whether the ratio between the positive and the negative sequence currents are supervised or whether only the negative sequence is used in detecting unbalance. |

### Pick-up settings

The setting parameters  $I_{2set}$  and  $I_{2/I1set}$  control the the pick-up of the I<sub>2</sub>> function. They define the maximum allowed measured negative sequence current or the negative/positive sequence current ratio before action from the function. The function constantly calculates the ratio between the  $I_{set}$  and the measured magnitude ( $I_m$ ). The reset ratio of 97 % is built into the function and is always relative to the  $I_{xset}$  value. The reset ratio is the same for both modes.

Setting group selection controls the operating characteristics of the function, i.e. the user or user-defined logic can change function parameters while the function is running.

Table. 4.4.6 - 86. Pick-up settings.

| Name     | Range                       | Step                | Default            | Description                    |
|----------|-----------------------------|---------------------|--------------------|--------------------------------|
| I2set    | 0.01...40.00×I <sub>n</sub> | 0.01×I <sub>n</sub> | 0.2×I <sub>n</sub> | Pick-up setting for I2 mode    |
| I2/I1set | 1...200%                    | 0.01%               | 20%                | Pick-up setting for I2/I1 mode |

### Read-only parameters

The function's *Info* page displays useful, real-time information on the state of the protection function. It is accessed either through the device's HMI display, or through the setting tool software when it is connected to the device and its Live Edit mode is active.

Table. 4.4.6 - 87. Information displayed by the function.

| Name             | Range  | Description  |
|------------------|--|--|
| I2> LN behaviour | On<br>Blocked<br>Test<br>Test/<br>Blocked<br>Off | Displays the mode of CUB block.<br>This parameter is visible only when <i>Allow setting of individual LN mode</i> is enabled in <i>General</i> menu. |
| I2> condition    | Normal<br>Start<br>Trip<br>Blocked               | Displays the status of the protection function.  |

### Function blocking

The blocking signal is evaluated at the start of each program cycle. The blocking signals are connected to the function's dedicated input, which can be configured in the *IO* → *Blocking Input Control* tab of the function.

- When the pick-up element activates and the blocking signal is not active, a START signal is generated, and the function starts or continues with the trip time countdown.
- When the pick-up element activates and the blocking signal is active, a BLOCKED signal is generated, and the function does not process the event further.
- When a START signal is already active and the blocking input signal becomes active, the START signal is reset and BLOCKED signal is generated. The release time characteristics are then processed in the same way as when the pick-up signal is reset.

The blocking signal needs to reach the device minimum of 5 ms before the set operating delay has passed in order for the blocking to activate in time.

### Operating time characteristics for trip and reset

The operating timers' behavior during a function can be set for TRIP signal and also for the release of the function in case the pick-up element is reset before the trip time has been reached. There are three basic operating modes available for the function:

- Instant operation: gives the TRIP signal with no additional time delay simultaneously with the start signal.
- Definite time operation (DT): gives the TRIP signal after a user-defined time delay regardless of the measured current as long as the current is above or below the  $i_{set}$  value and thus the pick-up element is active (independent time characteristics).

- Inverse definite minimum time (IDMT): gives the TRIP signal after a time which is in relation to the set pick-up value  $I_{set}$  and the measured current  $I_m$  (dependent time characteristics).

Both IEC and IEEE/ANSI standard characteristics as well as user settable parameters are available for the IDMT operation.

Unique to the current unbalance protection is the availability of the "Curve2" delay which follows the formula below:

$$t = \frac{k}{I_{2meas}^2 - I_{set}^2}$$

- $t$  = Operating time
- $I_{2meas}$  = Calculated negative sequence
- $k$  = Constant  $k$  value (user settable delay multiplier)
- $I_{set}$  = Pick-up setting of the function

Figure. 4.4.6 - 42. Operation characteristics curve for  $I_2 >$  Curve2.

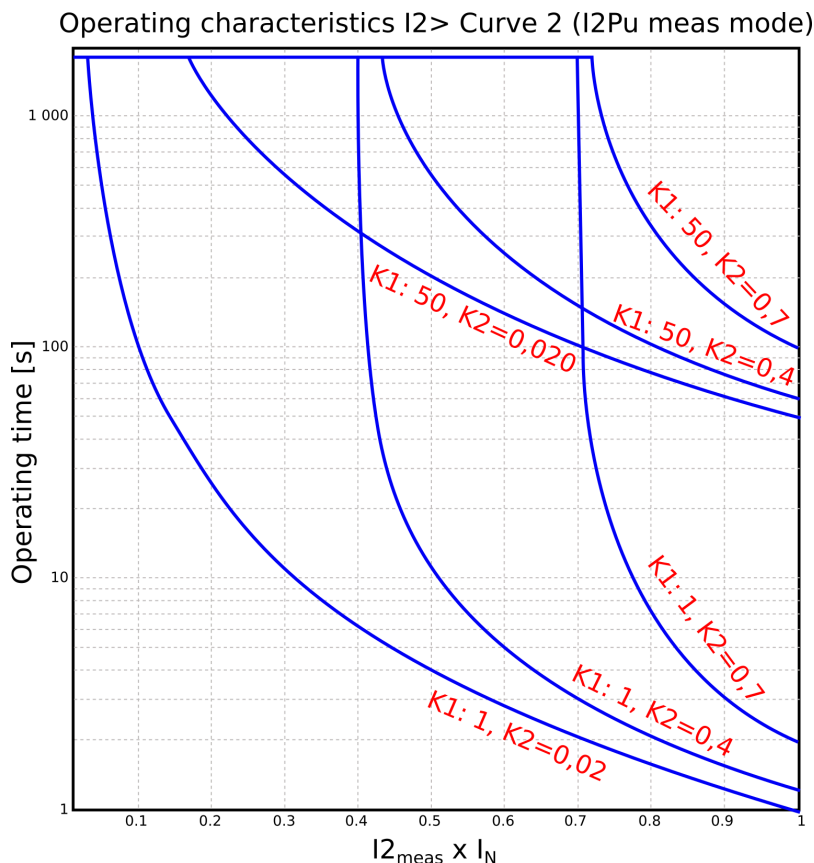

For a more detailed description on the time characteristics and their setting parameters, please refer to the "[General properties of a protection function](#)" chapter and its "[Operating time characteristics](#)" section.

## Events and registers

The current unbalance function (abbreviated "CUB" in event block names) generates events and registers from the status changes in the events listed below. The user can select which event messages are stored in the main event buffer: ON, OFF, or both. The events triggered by the function are recorded with a time stamp.

The function's outputs can be used for direct I/O controlling and user logic programming. The function also provides a resettable cumulative counter for the START, TRIP and BLOCKED events.

The function offers four (4) independent stages; the events are segregated for each stage operation.

Table. 4.4.6 - 88. Event messages.

| Event block name | Event names  |
|------------------|--------------|
| CUB1...CUB4      | Start ON/OFF |
| CUB1...CUB4      | Trip ON/OFF  |
| CUB1...CUB4      | Block ON/OFF |

The function registers its operation into the last twelve (12) time-stamped registers. The register of the function records the ON event process data for START, TRIP or BLOCKED. The table below presents the structure of the function's register content.

Table. 4.4.6 - 89. Register content.

| Register             | Description                |
|----------------------|----------------------------|
| Event                | Event name                 |
| Date and time        | dd.mm.yyyy hh:mm:ss.mss    |
| Pre-trigger current  | Start/Trip -20ms current   |
| Fault current        | Start/Trip current         |
| Pre-fault current    | Start -200ms current       |
| Fault currents       | I1, I2, IZ mag. and ang.   |
| Trip time remaining  | 0 ms...1800s               |
| Setting group in use | Setting group 1...8 active |

#### 4.4.7 Harmonic overcurrent protection (Ih>; 50H/51H/68H)

The harmonic overcurrent function is used for non-directional instant and time-delayed overcurrent detection and clearing. The number of stages in the function depends on the device model. The function constantly measures the selected harmonic component of the selected measurement channels, the value being either absolute value or relative to the RMS value.

Figure. 4.4.7 - 43. Simplified function block diagram of the I<sub>h</sub>> function.

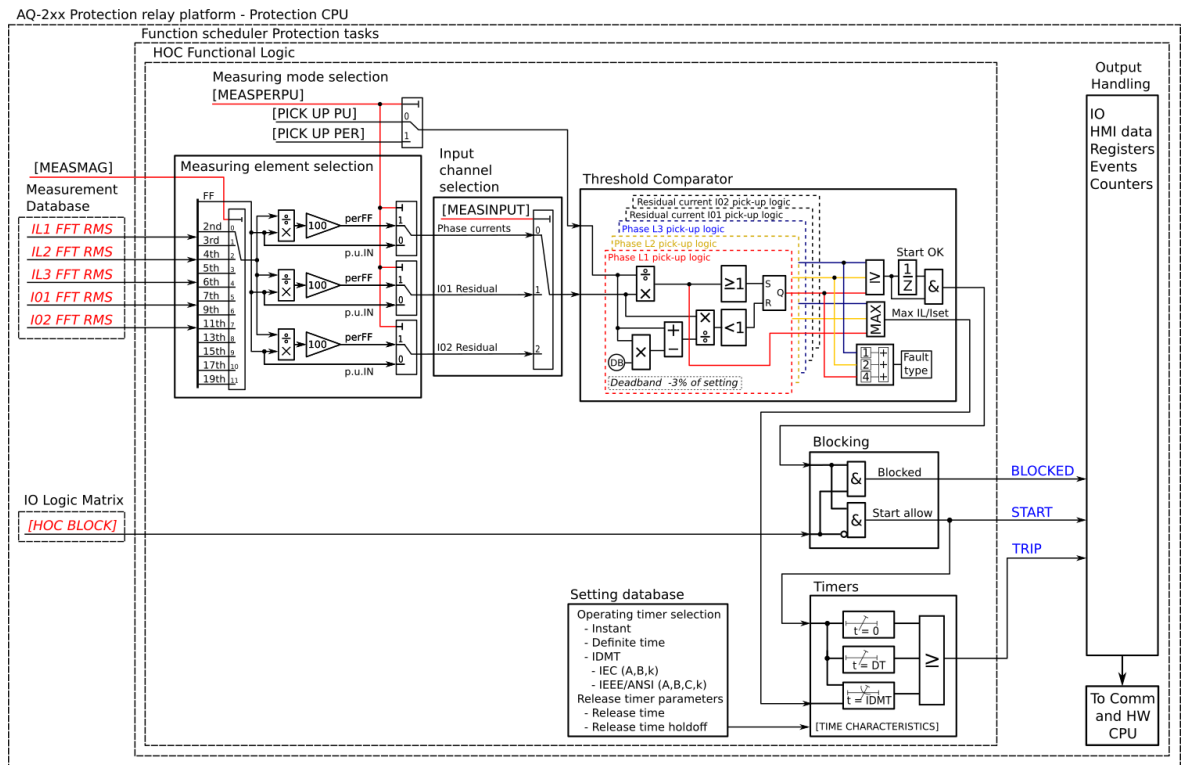

### Measured input

The function block uses analog current measurement values from phase or residual currents. Each measurement input of the function block uses RMS (fundamental frequency component) values and harmonic components of the selected current input. The user can select the monitored magnitude to be equal to the per-unit RMS values of the harmonic component, or to the harmonic component percentage content compared to the RMS values.

Table. 4.4.7 - 90. Measurement inputs of the I<sub>h</sub>> function.

| Signal              | Description  |
|---------------------|--|
| I <sub>L1</sub> FFT | The magnitudes (RMS) of phase L1 (A) current components: <ul style="list-style-type: none"> <li>- Fundamental</li> <li>- 2<sup>nd</sup> harmonic</li> <li>- 3<sup>rd</sup> harmonic</li> <li>- 4<sup>th</sup> harmonic</li> <li>- 5<sup>th</sup> harmonic</li> <li>- 6<sup>th</sup> harmonic</li> <li>- 7<sup>th</sup> harmonic</li> <li>- 9<sup>th</sup> harmonic</li> <li>- 11<sup>th</sup> harmonic</li> <li>- 13<sup>th</sup> harmonic</li> <li>- 15<sup>th</sup> harmonic</li> <li>- 17<sup>th</sup> harmonic</li> <li>- 19<sup>th</sup> harmonic.</li> </ul> |

| Signal              | Description  |
|---------------------|--|
| I <sub>L2</sub> FFT | <p>The magnitudes (RMS) of phase L2 (B) current components:</p> <ul style="list-style-type: none"> <li>- Fundamental</li> <li>- 2<sup>nd</sup> harmonic</li> <li>- 3<sup>rd</sup> harmonic</li> <li>- 4<sup>th</sup> harmonic</li> <li>- 5<sup>th</sup> harmonic</li> <li>- 6<sup>th</sup> harmonic</li> <li>- 7<sup>th</sup> harmonic</li> <li>- 9<sup>th</sup> harmonic</li> <li>- 11<sup>th</sup> harmonic</li> <li>- 13<sup>th</sup> harmonic</li> <li>- 15<sup>th</sup> harmonic</li> <li>- 17<sup>th</sup> harmonic</li> <li>- 19<sup>th</sup> harmonic.</li> </ul>            |
| I <sub>L3</sub> FFT | <p>The magnitudes (RMS) of phase L3 (C) current components:</p> <ul style="list-style-type: none"> <li>- Fundamental</li> <li>- 2<sup>nd</sup> harmonic</li> <li>- 3<sup>rd</sup> harmonic</li> <li>- 4<sup>th</sup> harmonic</li> <li>- 5<sup>th</sup> harmonic</li> <li>- 6<sup>th</sup> harmonic</li> <li>- 7<sup>th</sup> harmonic</li> <li>- 9<sup>th</sup> harmonic</li> <li>- 11<sup>th</sup> harmonic</li> <li>- 13<sup>th</sup> harmonic</li> <li>- 15<sup>th</sup> harmonic</li> <li>- 17<sup>th</sup> harmonic</li> <li>- 19<sup>th</sup> harmonic.</li> </ul>            |
| I <sub>01</sub> FFT | <p>The magnitudes (RMS) of residual I<sub>01</sub> current components:</p> <ul style="list-style-type: none"> <li>- Fundamental</li> <li>- 2<sup>nd</sup> harmonic</li> <li>- 3<sup>rd</sup> harmonic</li> <li>- 4<sup>th</sup> harmonic</li> <li>- 5<sup>th</sup> harmonic</li> <li>- 6<sup>th</sup> harmonic</li> <li>- 7<sup>th</sup> harmonic</li> <li>- 9<sup>th</sup> harmonic</li> <li>- 11<sup>th</sup> harmonic</li> <li>- 13<sup>th</sup> harmonic</li> <li>- 15<sup>th</sup> harmonic</li> <li>- 17<sup>th</sup> harmonic</li> <li>- 19<sup>th</sup> harmonic.</li> </ul> |

| Signal              | Description   |
|---------------------|---|
| I <sub>02</sub> FFT | The magnitudes (RMS) of residual I <sub>02</sub> current components:<br>- Fundamental<br>- 2 <sup>nd</sup> harmonic<br>- 3 <sup>rd</sup> harmonic<br>- 4 <sup>th</sup> harmonic<br>- 5 <sup>th</sup> harmonic<br>- 6 <sup>th</sup> harmonic<br>- 7 <sup>th</sup> harmonic<br>- 9 <sup>th</sup> harmonic<br>- 11 <sup>th</sup> harmonic<br>- 13 <sup>th</sup> harmonic<br>- 15 <sup>th</sup> harmonic<br>- 17 <sup>th</sup> harmonic<br>- 19 <sup>th</sup> harmonic. |

### General settings

The function can be set to monitor the ratio between the measured harmonic and either the measured fundamental component or the per unit value of the harmonic current. The user must select the correct measurement input.

Table. 4.4.7 - 91. Operating mode selection settings.

| Name                 | Range  | Default | Description   |
|----------------------|--|---------|---|
| Ih> LN mode          | <ul style="list-style-type: none"> <li>On</li> <li>Blocked</li> <li>Test</li> <li>Test/Blocked</li> <li>Off</li> </ul> | On      | Set mode of HOC block.<br>This parameter is visible only when <i>Allow setting of individual LN mode</i> is enabled in <i>General</i> menu. |
| Ih> force status to  | <ul style="list-style-type: none"> <li>Normal</li> <li>Start</li> <li>Trip</li> <li>Blocked</li> </ul>                 | Normal  | Force the status of the function. Visible only when <i>Enable stage forcing</i> parameter is enabled in <i>General</i> menu.                |
| Ih> measurement side | <ul style="list-style-type: none"> <li>Side 1</li> <li>Side 2</li> </ul>   | Side 1  | Defines which current measurement module is used by the function. Visible if the unit has more than one current measurement module.         |

| Name                 | Range   | Default                  | Description  |
|----------------------|---|--------------------------|--|
| Harmonic selection   | <ul style="list-style-type: none"> <li>• 2<sup>nd</sup> harmonic</li> <li>• 3<sup>rd</sup> harmonic</li> <li>• 4<sup>th</sup> harmonic</li> <li>• 5<sup>th</sup> harmonic</li> <li>• 6<sup>th</sup> harmonic</li> <li>• 7<sup>th</sup> harmonic</li> <li>• 9<sup>th</sup> harmonic</li> <li>• 11<sup>th</sup> harmonic</li> <li>• 13<sup>th</sup> harmonic</li> <li>• 15<sup>th</sup> harmonic</li> <li>• 17<sup>th</sup> harmonic</li> <li>• 19<sup>th</sup> harmonic</li> </ul> | 2 <sup>nd</sup> harmonic | Selection of the monitored harmonic component.   |
| Per unit or relative | <ul style="list-style-type: none"> <li>• <math>\times I_n</math></li> <li>• <math>I_h/IL</math></li> </ul>  | $\times I_n$             | Selection of the monitored harmonic mode. Either directly per unit $\times I_n$ or in relation to the fundamental frequency magnitude. |
| Measurement input    | <ul style="list-style-type: none"> <li>• IL1/IL2/IL3</li> <li>• I01</li> <li>• I02</li> </ul>   | IL1/IL2/IL3              | Selection of the measurement input (either phase current or residual current).   |

### Pick-up settings

The setting parameter  $I_{hset}$  per unit or  $I_h/IL$  (depending on the selected operating mode) controls the pick-up of the  $I_h >$  function. This defines the maximum allowed measured current before action from the function. The function constantly calculates the ratio between the  $I_{hset}$  per unit or  $I_h/IL$  and the measured magnitude ( $I_m$ ) for each of the three phases. The reset ratio of 97 % is built into the function and is always relative to the  $I_{hset}$  per unit or  $I_h/IL$  value. The setting value is common for all measured phases, and when the  $I_m$  exceeds the  $I_{set}$  value (in single, dual or all phases) it triggers the pick-up operation of the function.

Setting group selection controls the operating characteristics of the function, i.e. the user or user-defined logic can change function parameters while the function is running.

Table. 4.4.7 - 92. Pick-up settings.

| Name          | Range                    | Step              | Default           | Description                           |
|---------------|--------------------------|-------------------|-------------------|---------------------------------------|
| $I_{hset}$ pu | 0.05...2.00 $\times I_n$ | 0.01 $\times I_n$ | 0.20 $\times I_n$ | Pick-up setting (per unit monitoring) |

| Name  | Range          | Step  | Default | Description                             |
|-------|----------------|-------|---------|---|
| Ih/IL | 5.00...200.00% | 0.01% | 20.00%  | Pick-up setting (percentage monitoring) |

### Read-only parameters

The function's *Info* page displays useful, real-time information on the state of the protection function. It is accessed either through the device's HMI display, or through the setting tool software when it is connected to the device and its Live Edit mode is active.

Table. 4.4.7 - 93. Information displayed by the function.

| Name                      | Range  | Step              | Description   |
|---------------------------|--|-------------------|---|
| Ih> behaviour             | <ul style="list-style-type: none"> <li>On</li> <li>Blocked</li> <li>Test</li> <li>Test/Blocked</li> <li>Off</li> </ul> | -                 | Displays the mode of HOC block.<br>This parameter is visible only when <i>Allow setting of individual LN mode</i> is enabled in <i>General</i> menu.  |
| Ih> condition             | <ul style="list-style-type: none"> <li>Normal</li> <li>Start</li> <li>Trip</li> <li>Blocked</li> </ul>                 | -                 | Displays the status of the protection function.   |
| Ih meas/<br>Ih set<br>now | $0.00...100000.00I_m/I_{set}$  | $0.01I_m/I_{set}$ | The ratio between the monitored residual current and the pick-up value.   |
| Expected operating time   | 0.000...1800.000s  | 0.005s            | Displays the expected operating time when a fault occurs. When IDMT mode is used, the expected operating time depends on the measured voltage value. If the measured voltage changes during a fault, the expected operating time changes accordingly. |
| Time remaining to trip    | -1800.000...1800.000s  | 0.005s            | When the function has detected a fault and counts down time towards a trip, this displays how much time is left before tripping occurs.   |

### Function blocking

The blocking signal is evaluated at the start of each program cycle. The blocking signals are connected to the function's dedicated input, which can be configured in the *IO* → *Blocking Input Control* tab of the function.

- When the pick-up element activates and the blocking signal is not active, a START signal is generated, and the function starts or continues with the trip time countdown.
- When the pick-up element activates and the blocking signal is active, a BLOCKED signal is generated, and the function does not process the event further.
- When a START signal is already active and the blocking input signal becomes active, the START signal is reset and BLOCKED signal is generated. The release time characteristics are then processed in the same way as when the pick-up signal is reset.

The blocking signal needs to reach the device minimum of 5 ms before the set operating delay has passed in order for the blocking to activate in time.

## Operating time characteristics for trip and reset

This function supports definite time delay (DT) and inverse definite minimum time delay (IDMT). For detailed information on these delay types please refer to the chapter "[General properties of a protection function](#)" and its section "[Operating time characteristics](#)".

## Events and registers

The harmonic overcurrent function (abbreviated "HOC" in event block names) generates events and registers from the status changes in the events listed below. The user can select which event messages are stored in the main event buffer: ON, OFF, or both. The events triggered by the function are recorded with a time stamp.

The function's outputs can be used for direct I/O controlling and user logic programming. The START signal can be used to block other stages; if the situation lasts longer, the TRIP signal can be used on other actions as time-delayed. The function also provides a resettable cumulative counter for the START, TRIP and BLOCKED events.

The function offers four (4) independent stages; the events are segregated for each stage operation.

Table. 4.4.7 - 94. Event description.

| Event block name | Event names  |
|------------------|--------------|
| HOC1...HOC4      | Start ON/OFF |
| HOC1...HOC4      | Trip ON/OFF  |
| HOC1...HOC4      | Block ON/OFF |

The function registers its operation into the last twelve (12) time-stamped registers. The register of the function records the ON event process data for START, TRIP or BLOCKED. The table below presents the structure of the function's register content.

Table. 4.4.7 - 95. Register content.

| Register             | Description                |
|----------------------|----------------------------|
| Date and time        | dd.mm.yyyy hh:mm:ss.mss    |
| Event                | Event name                 |
| Fault type           | L1-G...L1-L2-L3            |
| Pre-trigger current  | Start/Trip -20ms current   |
| Fault current        | Start/Trip current         |
| Pre-fault current    | Start -200ms current       |
| Trip time remaining  | 0 ms...1800s               |
| Setting group in use | Setting group 1...8 active |

### 4.4.8 Circuit breaker failure protection (CBFP; 50BF/52BF)

The circuit breaker failure protection function is used for monitoring the circuit breaker operation after it has received a TRIP signal. The function can also be used to retrip a failing breaker; if the retrip fails, an incoming feeder circuit breaker can be tripped by using the function's CBFP output. The retrip functionality can be disabled if the breaker does not have two trip coils.

The function can be triggered by the following:

- overcurrent (phase and residual)
- digital output monitor
- digital signal
- any combination of the above-mentioned triggers.

In the current-dependent mode the function constantly measures phase current magnitudes and the selected residual current. In the signal-dependent mode any of the device's binary signals (trips, starts, logical signals etc.) can be used to trigger the function. In the digital output-dependent mode the function monitors the status of the selected output relay control signal.

Figure. 4.4.8 - 44. Simplified function block diagram of the CBFP function.

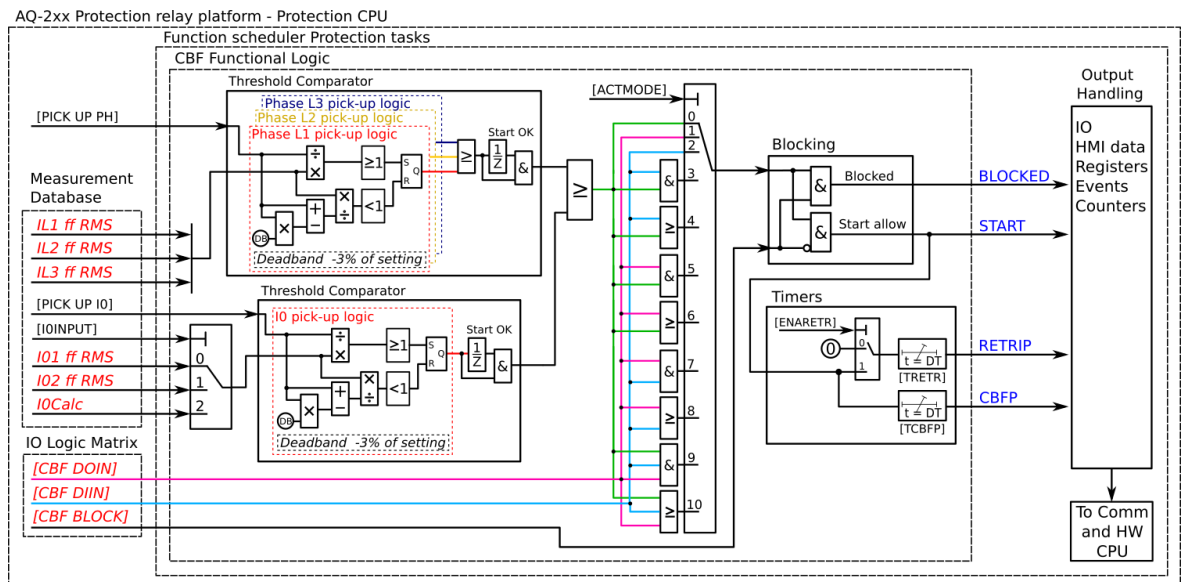

#### Measured input

The function block uses fundamental frequency component of phase current and residual current measurement values. The user can select I01, I02 or the calculated I0 for the residual current measurement.

Table. 4.4.8 - 96. Measurement inputs of the CBFP function.

| Signal      | Description  |
|-------------|--|
| $I_{L1RMS}$ | Fundamental frequency component of phase L1 (A) current measurement    |
| $I_{L2RMS}$ | Fundamental frequency component of phase L2 (B) current measurement    |
| $I_{L3RMS}$ | Fundamental frequency component of phase L3 (C) current measurement    |
| $I_{01RMS}$ | Fundamental frequency component of residual input $I_{01}$ measurement |

| Signal              | Description   |
|---------------------|---|
| I <sub>02</sub> RMS | Fundamental frequency component of residual input I <sub>02</sub> measurement |
| I <sub>0</sub> Calc | Calculated residual current from the phase current inputs                     |

## General settings

The following general settings define the general behavior of the function. These settings are static i.e. it is not possible to change them by editing the setting group.

Table. 4.4.8 - 97. CBFP monitoring signal definitions.

| Name              | Description  |
|-------------------|--|
| Signal in monitor | Defines which TRIP events of the used protection functions trigger the CBFP countdown. For the CBFP function to monitor the signals selected here, the "Operation mode selection" parameter must be set to a mode that includes signals (e.g. "Signals only", "Signals or DO", "Current and signals and DO").          |
| Trip monitor      | Defines which output relay of the used protection functions trigger the CBFP countdown. For the CBFP function to monitor the output relays selected here, the "Operation mode selection" parameter must be set to a mode that includes digital outputs (e.g. "DO only", "Current and DO", "Current or signals or DO"). |

Table. 4.4.8 - 98. General settings of the function.

| Name                 | Range  | Default | Description  |
|----------------------|--|---------|--|
| CBFP LN mode         | <ul style="list-style-type: none"> <li>• On</li> <li>• Blocked</li> <li>• Test</li> <li>• Test/Blocked</li> <li>• Off</li> </ul> | On      | Set mode of CBF block. This parameter is visible only when <i>Allow setting of individual LN mode</i> is enabled in <i>General</i> menu. |
| CBFP force status to | <ul style="list-style-type: none"> <li>• Normal</li> <li>• Start</li> <li>• ReTrip</li> <li>• CBFP</li> <li>• Blocked</li> </ul> | Normal  | Force the status of the function. Visible only when <i>Enable stage forcing</i> parameter is enabled in <i>General</i> menu.             |
| Measurement side     | <ul style="list-style-type: none"> <li>• Side 1</li> <li>• Side 2</li> </ul>   | Side 1  | Defines which current measurement module is used by the function.  |

## Pick-up settings

The setting parameters  $I_{set}$  and  $I_{0set}$  control the pick-up and the activation of the current-dependent CBFP function. They define the minimum allowed measured current before action from the function. The function constantly calculates the ratio between the  $I_{set}$  or the  $I_{0set}$  and the measured magnitude ( $I_m$ ) for each of the three phases and the selected residual current input. The reset ratio of 97 % is built into the function and is always relative to the  $I_{set}$  value. The setting value is common for all measured phases. When the  $I_m$  exceeds the  $I_{set}$  value (in single, dual or all phases) it triggers the pick-up operation of the function.

Setting group selection controls the operating characteristics of the function, i.e. the user or user-defined logic can change function parameters while the function is running.

Table. 4.4.8 - 99. Operating mode and input signals selection.

| Name    | Range  | Step | Default      | Description  |
|---------|--|------|--------------|--|
| I0Input | <ul style="list-style-type: none"> <li>• Not in use</li> <li>• I01</li> <li>• I02</li> <li>• I0Calc</li> </ul>   | -    | Not in use   | Selects the residual current monitoring source, which can be either from the two separate residual measurements (I01 and I02) or from the phase current's calculated residual current. |
| Actmode | <ul style="list-style-type: none"> <li>• Current only</li> <li>• DO only</li> <li>• Signals only</li> <li>• Current and DO</li> <li>• Current or DO</li> <li>• Current and signals</li> <li>• Current or signals</li> <li>• Signals and DO</li> <li>• Signals or DO</li> <li>• Current or DO or signals</li> <li>• Current and DO and Signals</li> </ul> | -    | Current only | Selects the operating mode. The mode can be dependent on current measurement, binary signal status, output relay status ("DO"), or a combination of the three.                         |

Table. 4.4.8 - 100. Pick-up settings.

| Name              | Range                         | Step                 | Default              | Description   |
|-------------------|-------------------------------|----------------------|----------------------|---|
| I <sub>set</sub>  | 0.01...40.00×I <sub>n</sub>   | 0.01×I <sub>n</sub>  | 0.20×I <sub>n</sub>  | The pick-up threshold for the phase current measurement. This setting limit defines the upper limit for the phase current pick-up element.    |
| I0 <sub>set</sub> | 0.005...40.000×I <sub>n</sub> | 0.001×I <sub>n</sub> | 1.200×I <sub>n</sub> | The pick-up threshold for the residual current measurement. This setting limit defines the upper limit for the phase current pick-up element. |

## Read-only parameters

The function's *Info* page displays useful, real-time information on the state of the protection function. It is accessed either through the device's HMI display, or through the setting tool software when it is connected to the device and its Live Edit mode is active.

Table. 4.4.8 - 101. Information displayed by the function.

| Name              | Range   | Description   |
|-------------------|---|---|
| CBFP LN behaviour | <ul style="list-style-type: none"> <li>• On</li> <li>• Blocked</li> <li>• Test</li> <li>• Test/Blocked</li> <li>• Off</li> </ul>    | <p>Displays the mode of CBF block.</p> <p>This parameter is visible only when <i>Allow setting of individual LN mode</i> is enabled in <i>General</i> menu.</p> |
| CBFP condition    | <ul style="list-style-type: none"> <li>• Normal</li> <li>• Start</li> <li>• ReTrip</li> <li>• CBFP On</li> <li>• Blocked</li> </ul> | <p>Displays status of the protection function.</p>  |

## Function blocking

The block signal is checked in the beginning of each program cycle. The blocking signal is received from the blocking matrix in the function's dedicated input. If the blocking signal is not activated when the pick-up element activates, a START signal is generated and the function proceeds to the time characteristics calculation.

If the blocking signal is active when the pick-up element activates, a BLOCKED signal is generated and the function does not process the situation further. If the START function has been activated before the blocking signal, it resets and processes the release time characteristics similarly to when the pick-up signal is reset.

The variables the user can set are binary signals from the system. The blocking signal needs to reach the device minimum of 5 ms before the set operating delay has passed in order for the blocking to activate in time.

## Operating time characteristics

The operating timers' behavior during a function can be set depending on the application. The same pick-up signal starts both timers. When retrip is used the time grading should be set as follows: the sum of specific times (i.e. the retrip time, the expected operating time, and the pick-up conditions' release time) is shorter the set CBFP time. This way, when retripping another breaker coil clears the fault, any unnecessary function triggers are avoided.

The following table presents the setting parameters for the function's operating time characteristics.

Table. 4.4.8 - 102. Setting parameters for operating time characteristics.

| Name   | Range   | Step | Default | Description  |
|--------|---|------|---------|--|
| Retrip | <ul style="list-style-type: none"> <li>• No</li> <li>• Yes</li> </ul> | -    | Yes     | Retrip enabled or disabled. When the retrip is disabled, the output will not be visible and the TRetr setting parameter will not be available. |

| Name              | Range             | Step   | Default | Description   |
|-------------------|-------------------|--------|---------|---|
| Retrip time delay | 0.000...1800.000s | 0.005s | 0.100s  | Retrip start the timer. This setting defines how long the starting condition has to last before a RETRIP signal is activated. |
| CBFP              | 0.000...1800.000s | 0.005s | 0.200s  | CBFP starts the timer. This setting defines how long the starting condition has to last before the CBFP signal is activated.  |

The following figures present some typical cases of the CBFP function.

### Trip, Retrip and CBFP in the device configuration

Figure. 4.4.8 - 45. Wiring diagram when Trip, Retrip and CBFP are configured to the device.

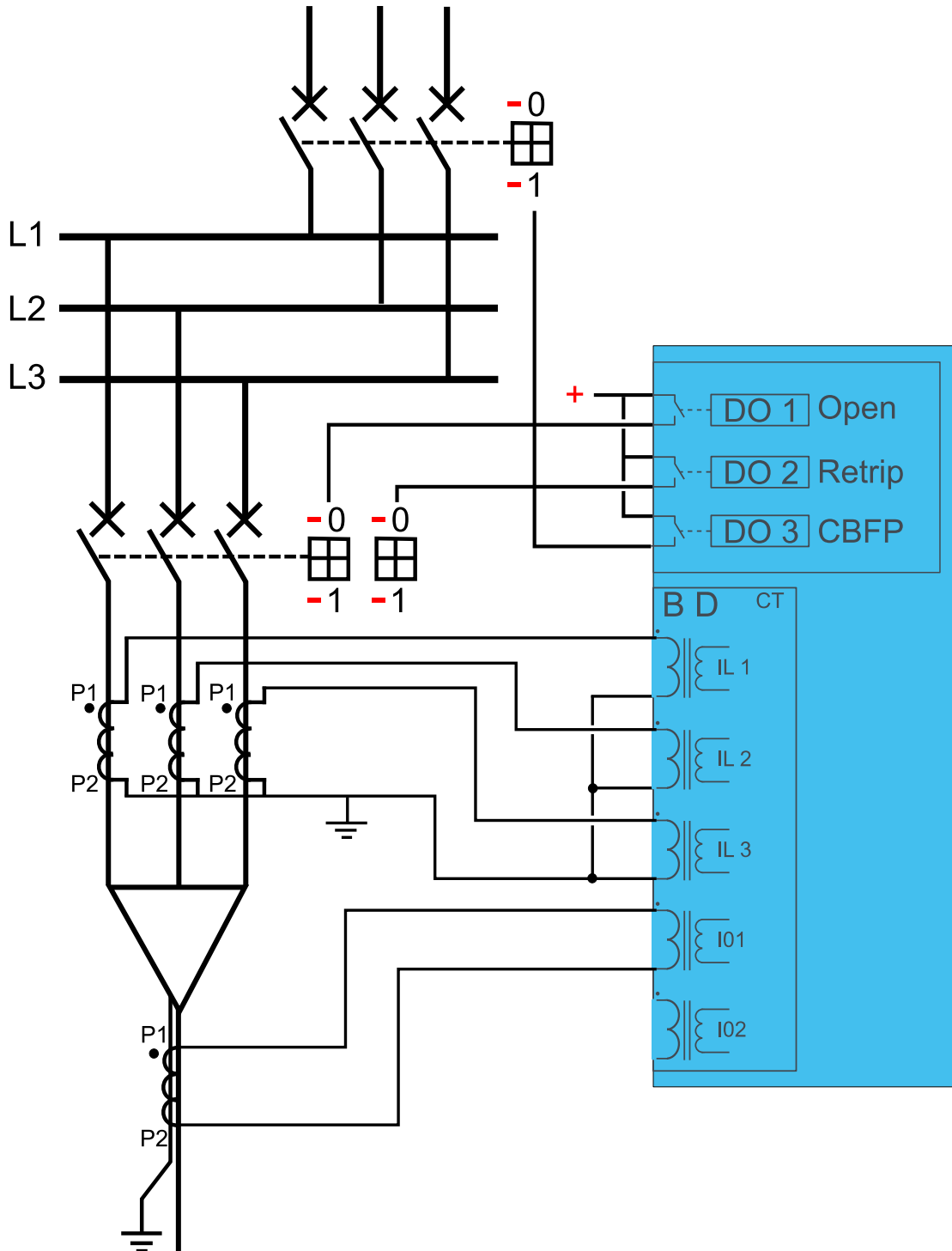

The retrip functionality can be used in applications whose circuit breaker has a retrip or a redundant trip coil available. The TRIP signal is normally wired to the breaker's trip coil from the device's trip output. The retrip is wired from its own device output contact in parallel with the circuit breaker's redundant trip coil. The CBFP signal is normally wired from its device output contact to the incoming feeder circuit breaker. Below are a few operational cases regarding the various applications.

Figure. 4.4.8 - 46. Retrip and CBFP when "Current" is the selected criterion.

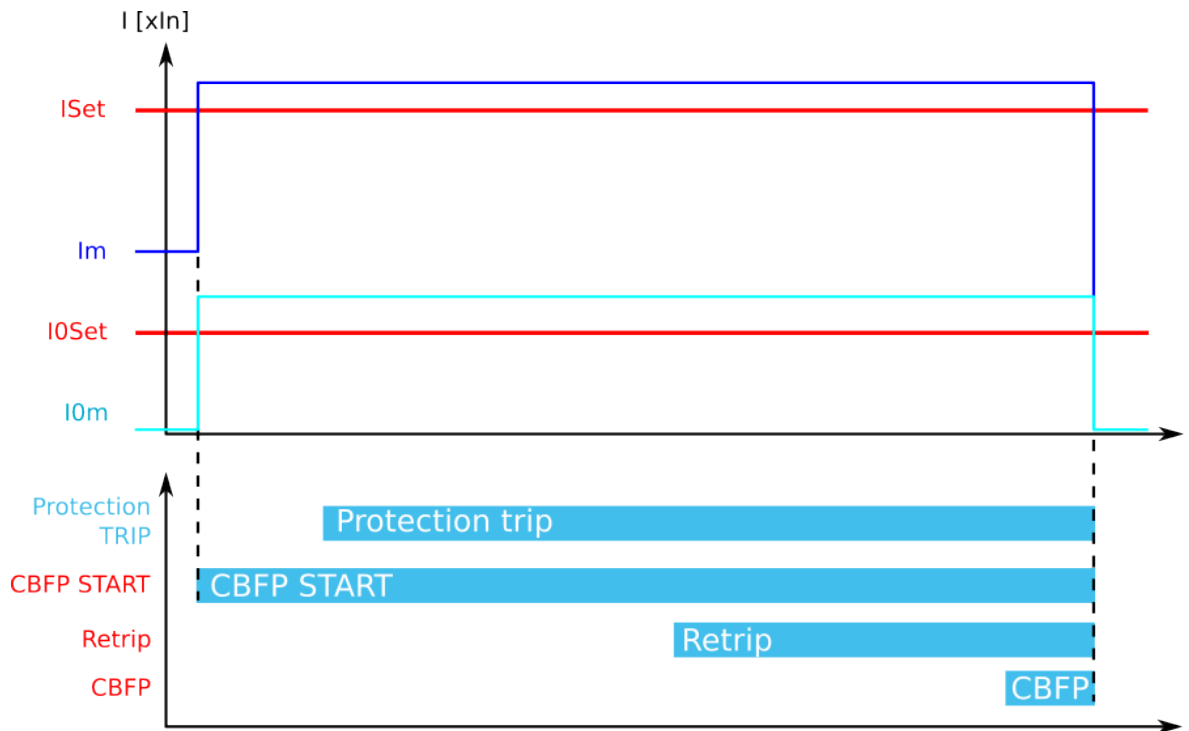

When the current threshold setting of  $I_{set}$  and/or  $I_{Oset}$  is exceeded, the current-based protection is activated and the counters for RETRIP and CBFP start calculating the set operating time. The tripping of the primary protection stage is not monitored in this configuration. Therefore, if the current is not reduced below the setting limit, a RETRIP signal is sent to the redundant trip coil. If the current is not reduced within the set time limit, the function also sends a CBFP signal to the incoming feeder breaker. If the primary protection function clears the fault, both counters (RETRIP and CBFP) are reset as soon as the measured current is below the threshold settings.

Figure. 4.4.8 - 47. Retrip and CBFP when "Current and DO" is the selected criterion.

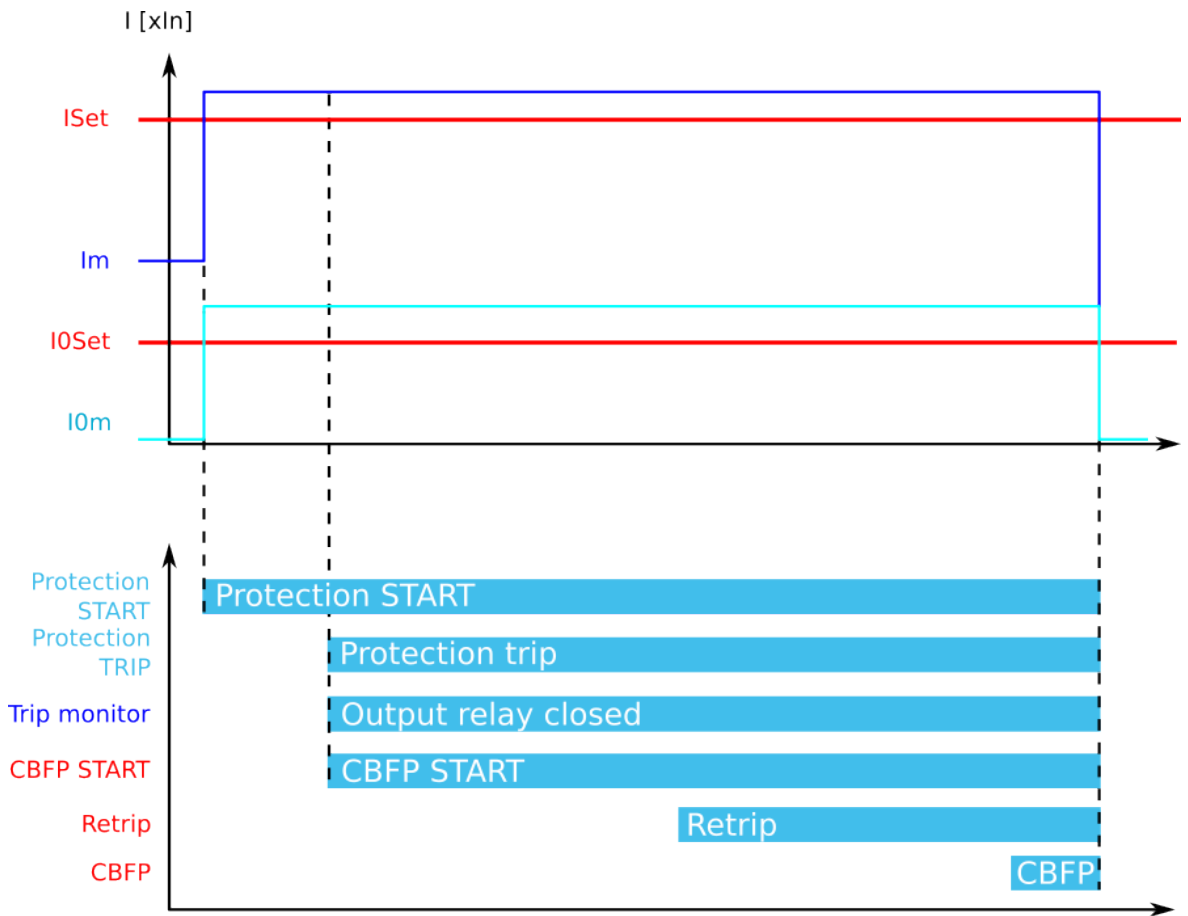

When the current threshold setting of  $I_{set}$  and/or  $I_{Oset}$  is exceeded, the current-based protection is activated. At the same time, the counters for RETRIP and CBFP are halted until the monitored output contact is controlled (that is, until the primary protection operates). When the tripping signal reaches the primary protection stage, the RETRIP and CBFP counters start calculating the set operating time. The tripping of the primary protection stage is constantly monitored in this configuration. If the current is not reduced below the setting limit or the primary stage tripping signal is not reset, a RETRIP signal is sent to the redundant trip coil. If the retripping fails and the current is not reduced below the setting limit or the primary stage tripping signal is not reset, the function also sends a CBFP signal to the incoming feeder circuit breaker. If the primary protection function clears the fault, both counters (RETRIP and CBFP) are reset as soon as the measured current is below the threshold settings or the tripping signal is reset. This configuration allows the CBFP to be controlled with current-based functions alone, and other function trips can be excluded from the CBFP functionality.

Figure. 4.4.8 - 48. Retrip and CBFP when "Current or DO" is the selected criterion.

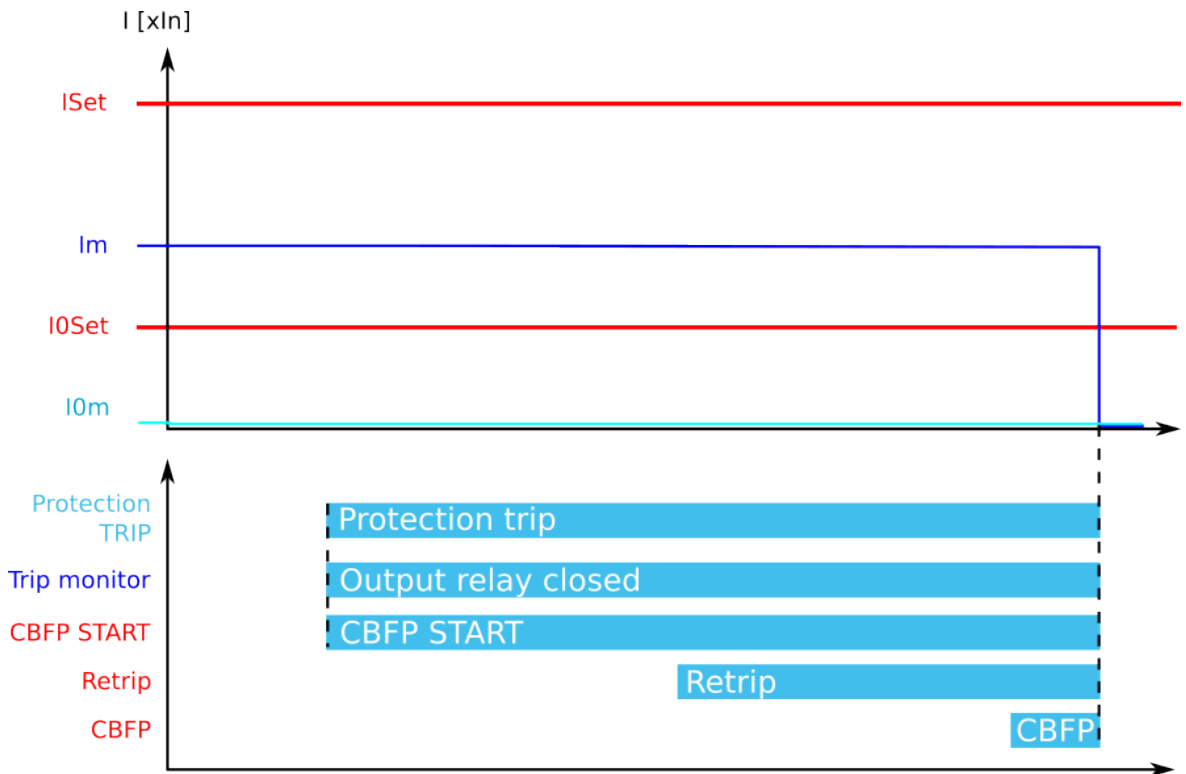

When the current threshold setting of  $I_{set}$  and/or  $I_{0set}$  is exceeded, or the TRIP signal reaches the primary protection stage, the function starts counting down towards the RETRIP and CBFP signals. The tripping of the primary protection stage is constantly monitored in this configuration regardless of the current's status. The pick-up of the CBFP is active unless the current is reduced below the setting limit and the primary stage tripping signal is reset. If either of these conditions is met (i.e. the current is above the limit or the signal is active) for the duration of the set RETRIP time delay, a RETRIP signal is sent to the redundant trip coil. If either of the conditions is active for the duration of the set CBFP time delay, a CBFP signal is sent to the incoming feeder circuit breaker. If the primary protection function clears the fault, both counters (RETRIP and CBFP) are reset as soon as the measured current is below the threshold settings and the tripping signal is reset. This configuration allows the CBFP to be controlled with current-based functions alone, with added security from current monitoring. Other function trips can also be included in the CBFP functionality.

### Trip and CBFP in the device configuration

Figure. 4.4.8 - 49. Wiring diagram when Trip and CBFP are configured to the device.

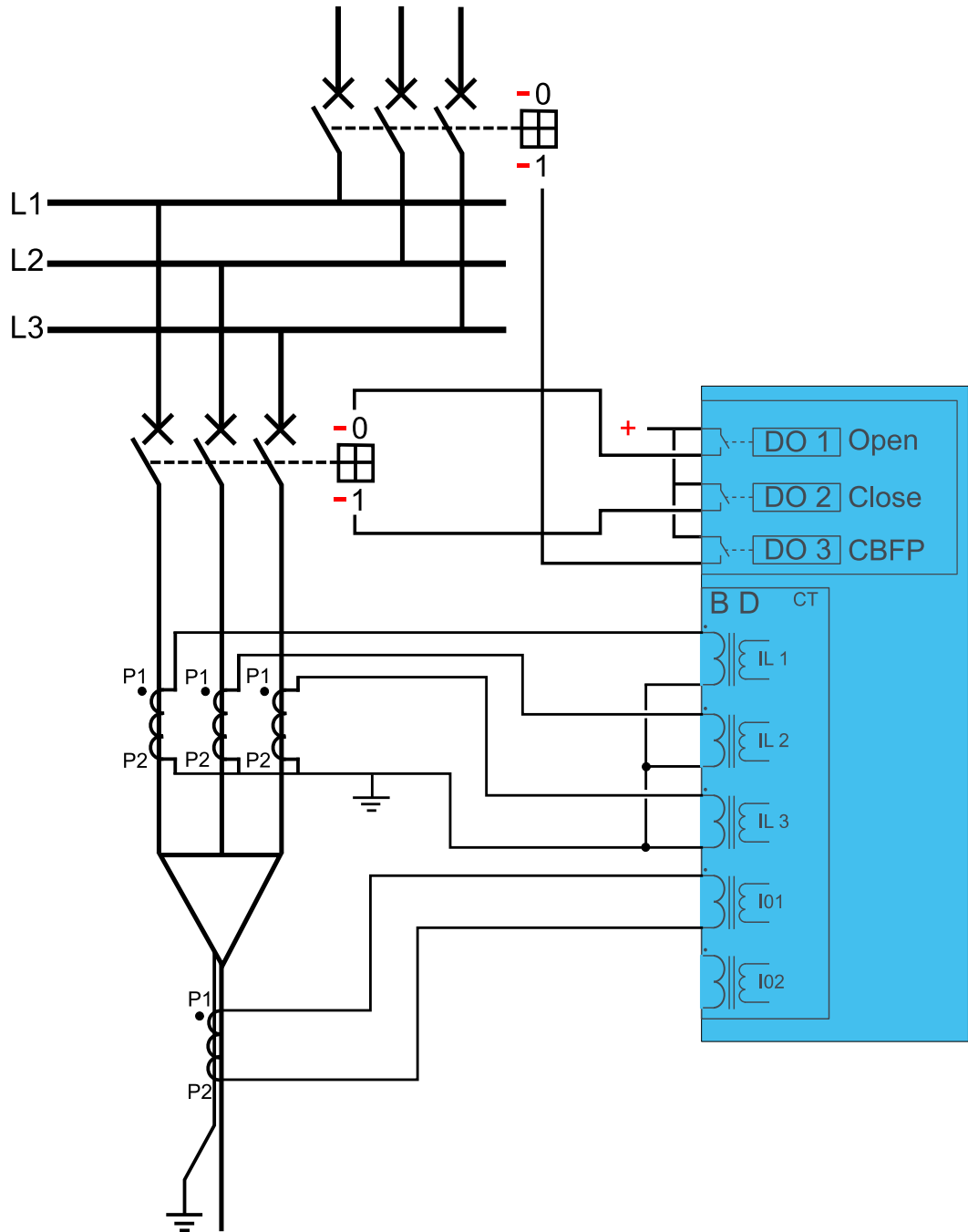

Probably the most common application is when the device's trip output controls the circuit breaker trip coil, while one dedicated CBFP contact controls the CBFP function. Below are a few operational cases regarding the various applications and settings of the CBFP function.

Figure. 4.4.8 - 50. CBFP when "Current" is the selected criterion.

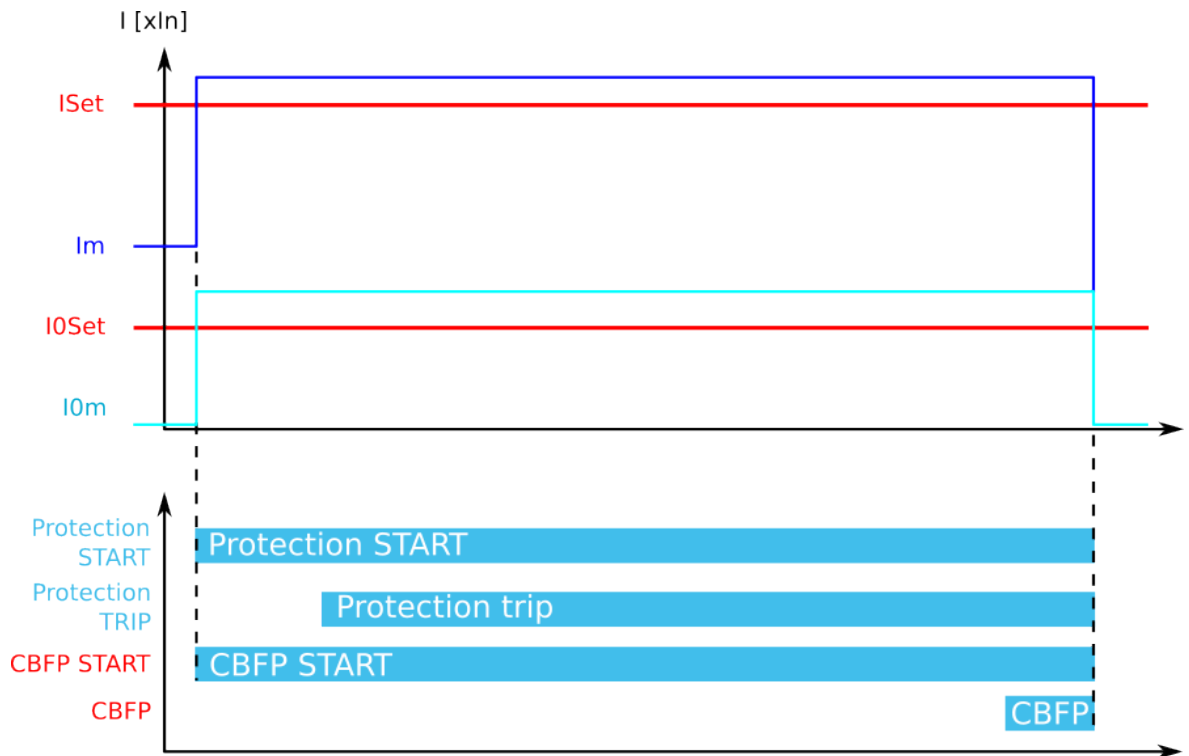

When the current threshold setting of  $I_{set}$  and/or  $I_{Oset}$  is exceeded, the current-based protection is activated and the counter for CBFP starts calculating the set operating time. The tripping of the primary protection stage is not monitored in this configuration. Therefore, if the current is not reduced below the setting limit, a CBFP signal is sent to the incoming feeder circuit breaker. If the primary protection function clears the fault, the counter for CBFP resets as soon as the measured current is below the threshold settings.

Figure. 4.4.8 - 51. CBFP when "Current and DO" is the selected criterion.

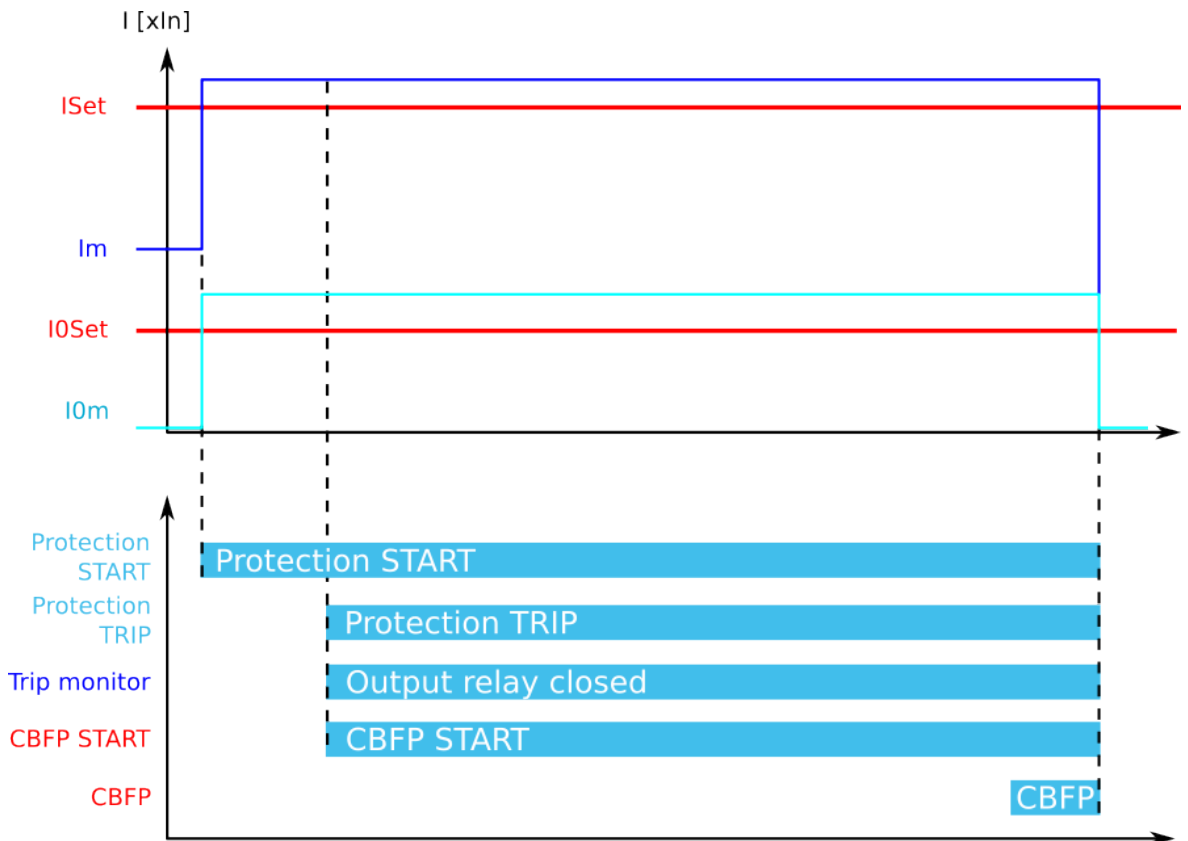

When the current threshold setting of  $I_{Set}$  and/or  $I_{OSet}$  is exceeded, the current-based protection is activated. At the same time, the counter for CBFP is halted until the monitored output contact is controlled (that is, until the primary protection operates). When the tripping signal reaches the primary protection stage, the CBFP counter starts calculating the set operating time. The tripping of the primary protection stage is constantly monitored in this configuration. If the current is not reduced below the setting limit or the primary stage tripping signal is not reset, a CBFP signal is sent to the incoming feeder circuit breaker. The time delay counter for CBFP is reset as soon as the measured current is below the threshold settings or the tripping signal is reset. This configuration allows the CBFP to be controlled by current-based functions alone, and other function trips can be excluded from the CBFP functionality.

Figure. 4.4.8 - 52. CBFP when "Current or DO" is the selected criterion.

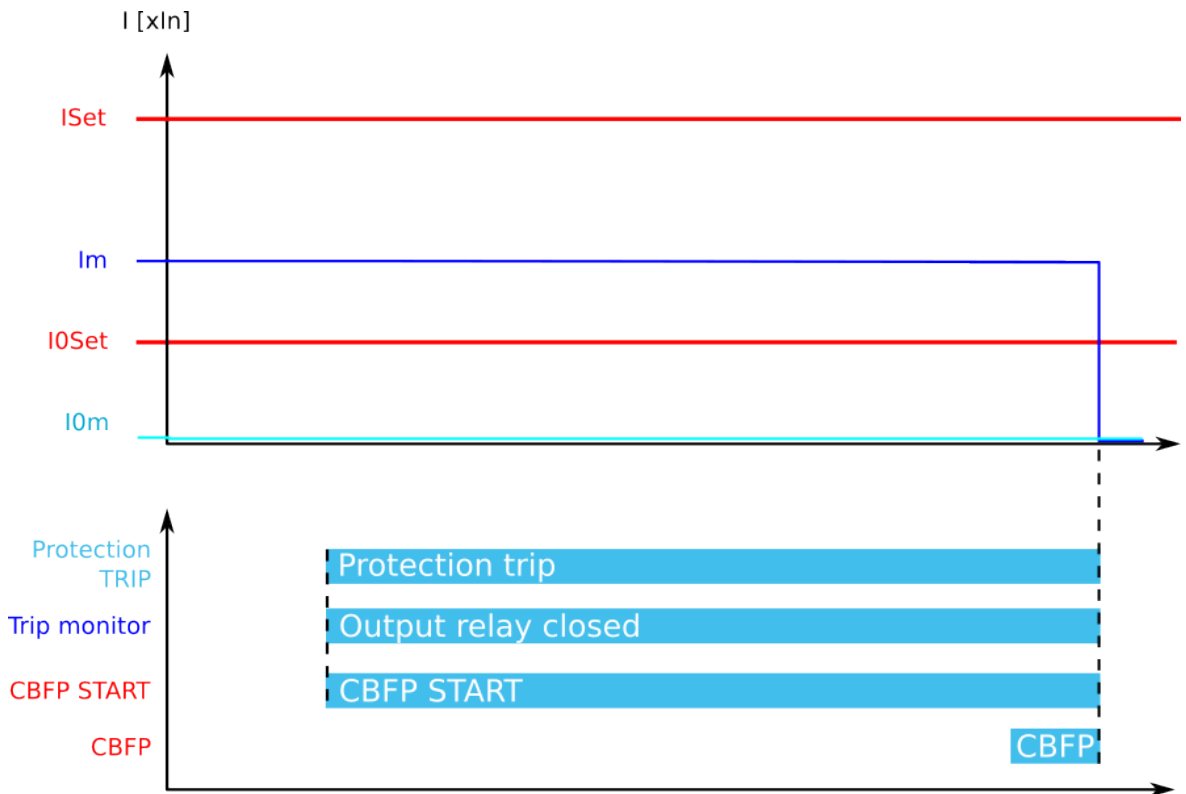

When the current threshold setting of  $I_{set}$  and/or  $I_{Oset}$  is exceeded, or the TRIP signal reaches the primary protection stage, the function starts counting down towards the CBFP signal. The tripping of the primary protection stage is constantly monitored in this configuration regardless of the current's status. The pick-up of the CBFP is active unless the current is reduced below the setting limit and the primary stage tripping signal is reset. If either of these conditions is met (i.e. the current is above the limit or the signal is active) for the duration of the set CBFP time delay, a CBFP signal is sent to the incoming feeder circuit breaker. The time delay counter for CBFP is reset as soon as the measured current is below the threshold settings and the tripping signal is reset. This configuration allows the CBFP to be controlled by current-based functions alone, with added security from current monitoring. Other function trips can also be included to the CBFP functionality.

## Device configuration as a dedicated CBFP unit

Figure. 4.4.8 - 53. Wiring diagram when the device is configured as a dedicated CBFP unit.

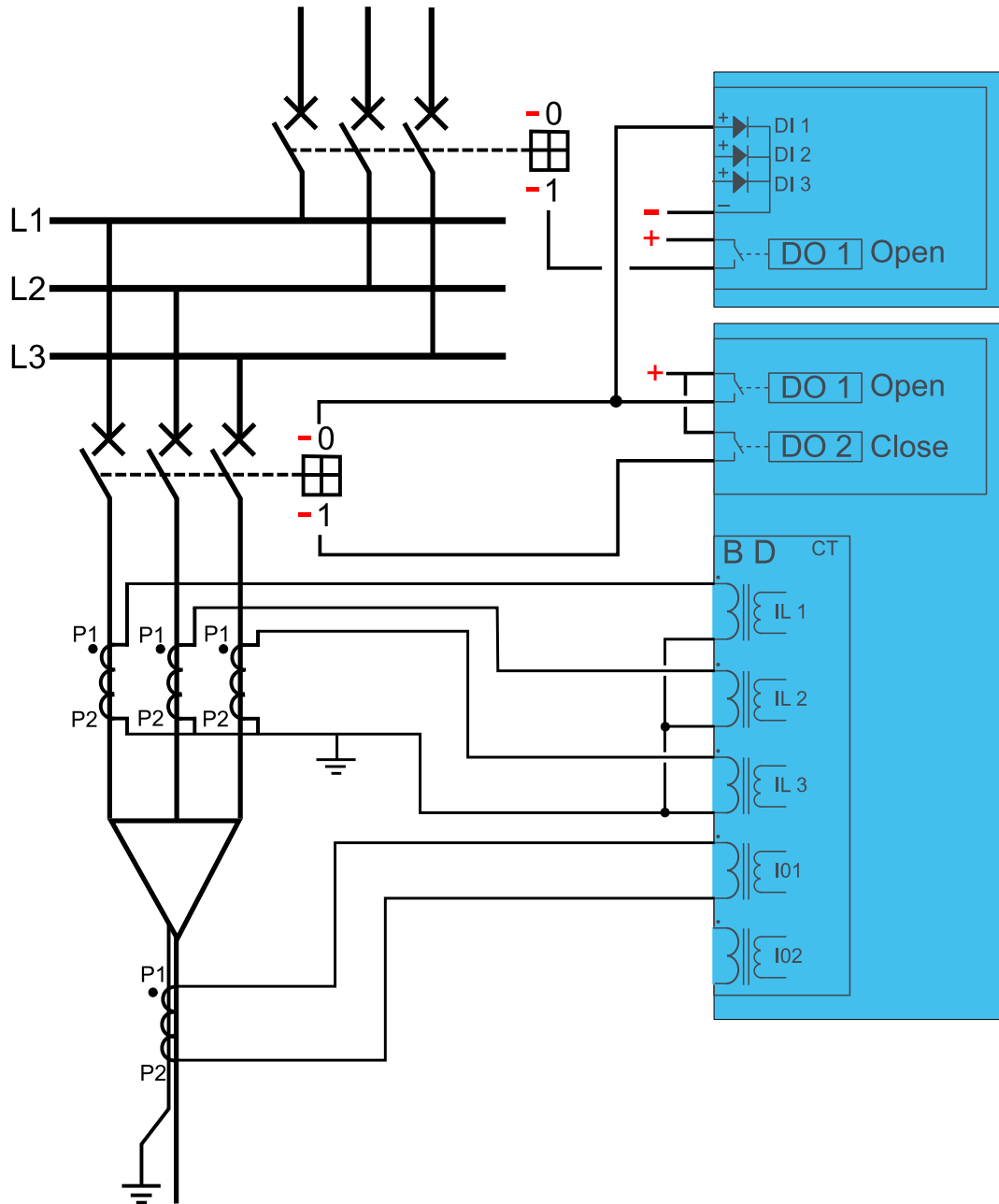

Some applications require a dedicated circuit breaker protection unit. When the CBFP function is configured to operate with a digital input signal, it can be used in these applications. When a device is used for this purpose, the tripping signal is wired to the device's digital input and the device's own TRIP signal is used only for the CBFP purpose. In this application's incoming feeder the RETRIP and CBFP signals are also available with different sets of requirements. The RETRIP signal can be used for tripping the section's feeder breaker and the CBFP signal for tripping the incoming feeder. The following example does not use retripping and the CBFP signal is used as the incoming feeder trip from the outgoing breaker trip signal. The TRIP signal can also be transported between different devices by using GOOSE messages.

Figure. 4.4.8 - 54. Dedicated CBFP operation from digital input signal.

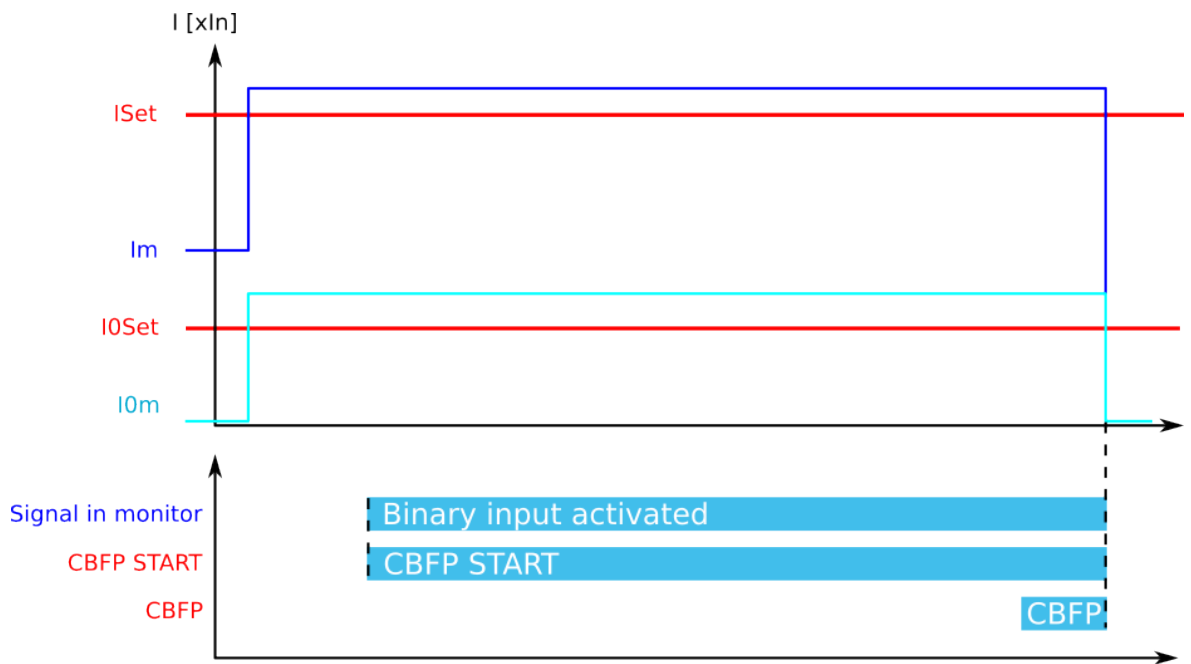

In this mode the CBFP operates only from a digital input signal. Both current and output relay monitoring can be used. The counter for the CBFP signal begins when the digital input is activated. If the counter is active until the CBFP counter is used, the device issues a CBFP command to the incoming feeder circuit breaker. In this application the device tripping signals from all outgoing feeders can be connected to one, dedicated CBFP device which operates either on current-based protection or on all possible faults' CBFP protection.

### Events and registers

The circuit breaker failure protection function (abbreviated "CBF" in event block names) generates events and registers from the status changes in the events listed below. The user can select which event messages are stored in the main event buffer: ON, OFF, or both. The events triggered by the function are recorded with a time stamp.

The function's outputs can be used for direct I/O controlling and user logic programming. The function also provides a resettable cumulative counters for RETRIP, CBFP, CBFP START and BLOCKED events.

Table. 4.4.8 - 103. Event messages.

| Event block name | Event names          |
|------------------|----------------------|
| CBF1             | Start ON/OFF         |
| CBF1             | Retrip ON/OFF        |
| CBF1             | CBFP ON/OFF          |
| CBF1             | Block ON/OFF         |
| CBF1             | DO monitor ON/OFF    |
| CBF1             | Signal ON/OFF        |
| CBF1             | Phase current ON/OFF |
| CBF1             | Res current ON/OFF   |

The function registers its operation into the last twelve (12) time-stamped registers. The register of the function records the ON event process data for ACTIVATED, BLOCKED, etc. The table below presents the structure of the function's register content.

Table. 4.4.8 - 104. Register content.

| Register             | Description                                     |
|----------------------|---|
| Date and time        | dd.mm.yyyy hh:mm:ss.mss                         |
| Event                | Event name                                      |
| Max phase current    | Highest phase current                           |
| Residual current     | I01, I02 channel or calculated residual current |
| Time to RETR         | Time remaining to retrip activation             |
| Time to CBFP         | Time remaining to CBFP activation               |
| Setting group in use | Setting group 1...8 active                      |

### 4.4.9 Overvoltage protection (U>; 59)

The overvoltage function is used for instant and time-delayed overvoltage protection. Devices with a voltage protection module has four (4) available stages of the function (U>, U>>, U>>>, U>>>>). The function constantly measures phase voltage magnitudes or line-to-line magnitudes.

Figure. 4.4.9 - 55. Simplified function block diagram of the U> function.

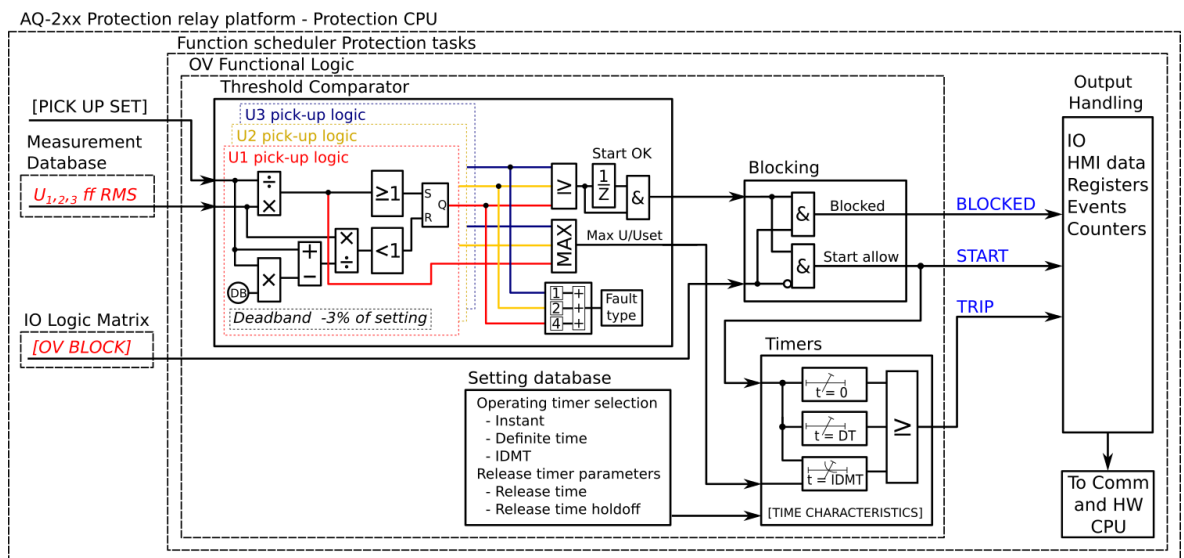

#### Measured input

The function block uses fundamental frequency component of line-to-line or line-to-neutral (as the user selects). If the protection is based on line-to-line voltage, overvoltage protection is not affected by earth faults in isolated or compensated networks.

Table. 4.4.9 - 105. Measurement input of the U> function.

| Signal               | Description  |
|----------------------|--|
| U <sub>L12</sub> RMS | Fundamental frequency component of U <sub>L12</sub> /V voltage measurement |
| U <sub>L23</sub> RMS | Fundamental frequency component of U <sub>L23</sub> /V voltage measurement |
| U <sub>L31</sub> RMS | Fundamental frequency component of U <sub>L31</sub> /V voltage measurement |
| U <sub>L1</sub> RMS  | Fundamental frequency component of U <sub>L1</sub> /V voltage measurement  |
| U <sub>L2</sub> RMS  | Fundamental frequency component of U <sub>L2</sub> /V voltage measurement  |
| U <sub>L3</sub> RMS  | Fundamental frequency component of U <sub>L3</sub> /V voltage measurement  |

Table. 4.4.9 - 106. Measured magnitude selection settings.

| Name               | Range  | Default      | Description   |
|--------------------|--|--------------|---|
| Measured magnitude | <ul style="list-style-type: none"> <li>• P-P voltages</li> <li>• P-E voltages</li> <li>• U3 input (2LL-U3SS)</li> <li>• U4 input (SS)</li> </ul> | P-P voltages | Selection of phase-to-phase or phase-to-earth voltages. Additionally, the U3 or U4 input can be assigned as the voltage channel to be supervised. |

Figure. 4.4.9 - 56. Selectable measurement magnitudes with 3LN+U4 VT connection.

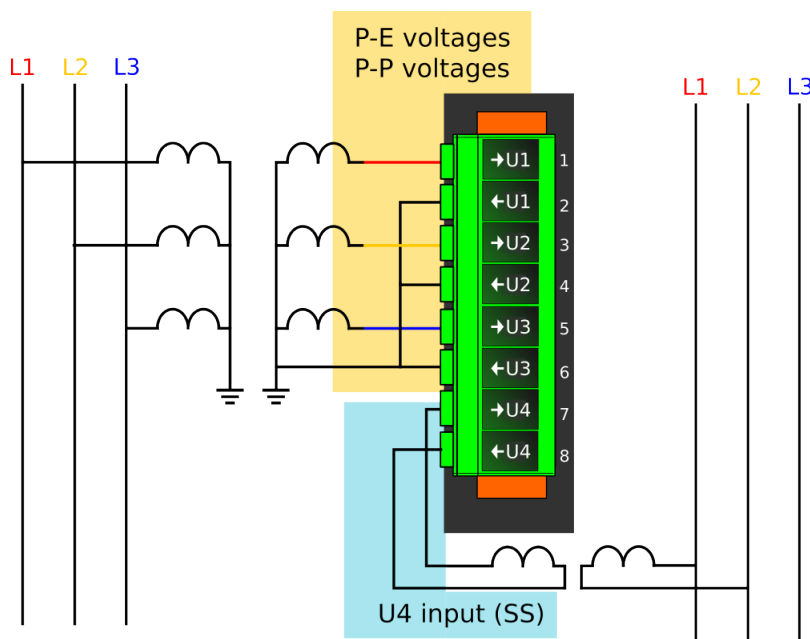

Figure. 4.4.9 - 57. Selectable measurement magnitudes with 3LL+U4 VT connection (P-E voltages not available without residual voltage).

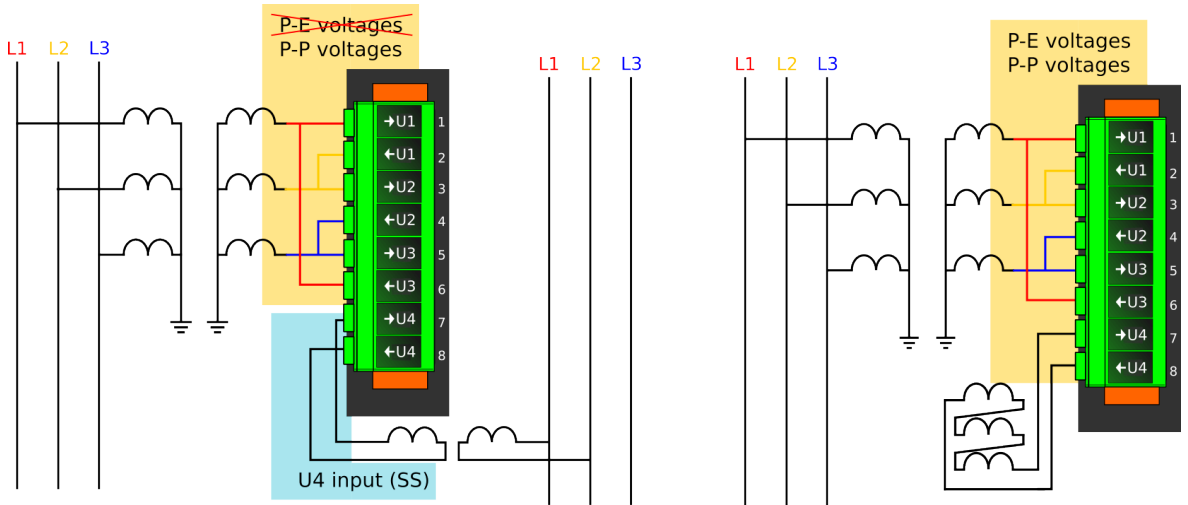
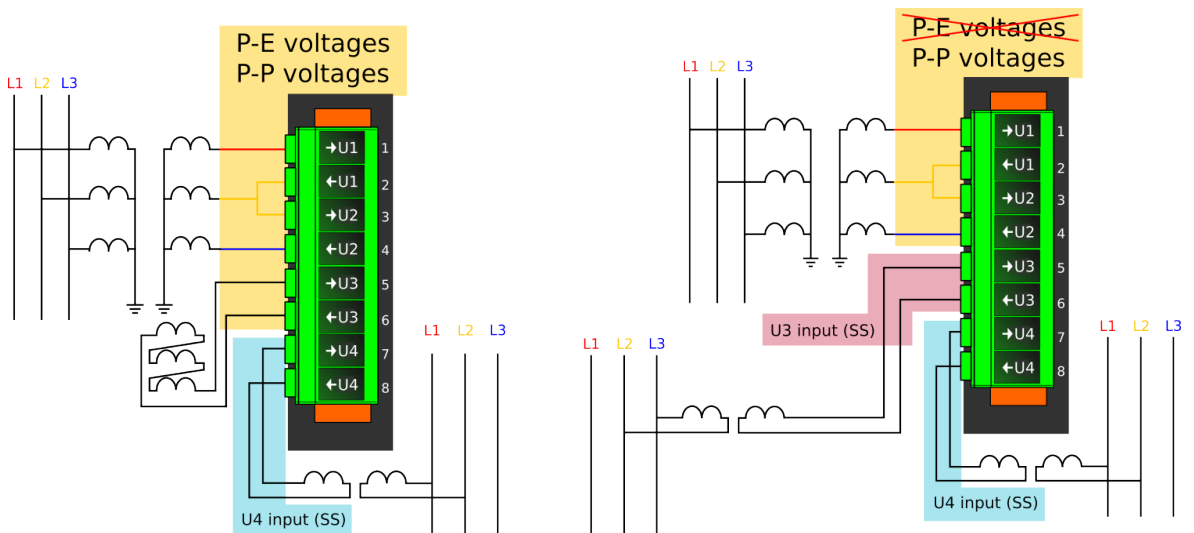

Figure. 4.4.9 - 58. Selectable measurement magnitudes with 2LL+U3+U4 VT connection (P-E voltages not available without residual voltage).



*P-P Voltages* and *P-E Voltages* selections follow phase-to-neutral or phase-to-phase voltages in the first three voltage channels (or two first voltage channels in the 2LL+U3+U4 mode). *U4 input* selection follows the voltage in Channel 4. *U3Input* selection only follows the voltage in Channel 3 if the 2LL+U3+U4 mode is in use.

## General settings

The following general settings define the general behavior of the function. These settings are static i.e. it is not possible to change them by editing the setting group.

Table. 4.4.9 - 107. General settings of the function.

| Name               | Range  | Default | Description  |
|--------------------|--|---------|--|
| U> LN mode         | <ul style="list-style-type: none"> <li>On</li> <li>Blocked</li> <li>Test</li> <li>Test/Blocked</li> <li>Off</li> </ul> | On      | Set mode of OV block.<br>This parameter is visible only when <i>Allow setting of individual LN mode</i> is enabled in <i>General</i> menu. |
| U> force status to | <ul style="list-style-type: none"> <li>Normal</li> <li>Start</li> <li>Trip</li> <li>Blocked</li> </ul>                 | Normal  | Force the status of the function. Visible only when <i>Enable stage forcing</i> parameter is enabled in <i>General</i> menu.               |

### Pick-up settings

The  $U_{set}$  setting parameter controls the pick-up of the U> function. This defines the maximum allowed measured voltage before action from the function. The function constantly calculates the ratio between the  $U_{set}$  and the measured magnitude ( $U_m$ ) for each of the three voltages. The reset ratio of 97 % is built into the function and is always relative to the  $U_{set}$  value. The setting value is common for all measured amplitudes, and when the  $U_m$  exceeds the  $U_{set}$  value (in single, dual or all voltages) it triggers the pick-up operation of the function.

Setting group selection controls the operating characteristics of the function, i.e. the user or user-defined logic can change function parameters while the function is running.

Table. 4.4.9 - 108. Pick-up settings.

| Name           | Range   | Step        | Default    | Description                |
|----------------|---|-------------|------------|----------------------------|
| Operation mode | <ul style="list-style-type: none"> <li>1 voltage</li> <li>2 voltages</li> <li>3 voltages</li> </ul> | -           | 1 voltage  | Pick-up criteria selection |
| $U_{set}$      | 0.01...250.00% $U_n$  | 0.01% $U_n$ | 105% $U_n$ | Pick-up setting            |

### Read-only parameters

The function's *Info* page displays useful, real-time information on the state of the protection function. It is accessed either through the device's HMI display, or through the setting tool software when it is connected to the device and its Live Edit mode is active.

Table. 4.4.9 - 109. Information displayed by the function.

| Name            | Range  | Step | Description   |
|-----------------|--|------|---|
| U> LN behaviour | <ul style="list-style-type: none"> <li>On</li> <li>Blocked</li> <li>Test</li> <li>Test/Blocked</li> <li>Off</li> </ul> | -    | Displays the mode of OV block.<br>This parameter is visible only when <i>Allow setting of individual LN mode</i> is enabled in <i>General</i> menu. |

| Name   | Range                        | Step               | Description   |
|--|------------------------------|--------------------|---|
| U< pick-up setting                             | 0.0...1 000 000.0V           | 0.1V               | The primary voltage required for tripping. The displayed pick-up voltage level depends on the pick-up setting and the voltage transformer settings.   |
| Expected operating time                        | 0.000...1800.000s            | 0.005s             | Displays the expected operating time when a fault occurs. When IDMT mode is used, the expected operating time depends on the measured voltage value. If the measured voltage changes during a fault, the expected operating time changes accordingly. |
| Time remaining to trip                         | -1800.000...1800.000s        | 0.005s             | When the function has detected a fault and counts down time towards a trip, this displays how much time is left before tripping occurs.   |
| $U_{A(B)}$<br>meas/ $U_{set}$<br>at the moment | 0.00...1250.00 $U_m/U_{set}$ | 0.01 $U_m/U_{set}$ | The ratio between $U_A$ or $U_{AB}$ voltage and the pick-up value.  |
| $U_{B(c)}$<br>meas/ $U_{set}$<br>at the moment | 0.00...1250.00 $U_m/U_{set}$ | 0.01 $U_m/U_{set}$ | The ratio between $U_B$ or $U_{BC}$ voltage and the pick-up value.  |
| $U_{C(A)}$<br>meas/ $U_{set}$<br>at the moment | 0.00...1250.00 $U_m/U_{set}$ | 0.01 $U_m/U_{set}$ | The ratio between $U_C$ or $U_{CA}$ voltage and the pick-up value.  |
| $U_{meas}/U_{set}$<br>at the moment            | 0.00...1250.00 $U_m/U_{set}$ | 0.01 $U_m/U_{set}$ | The ratio between the measured voltage and the pick-up value.   |

## Function blocking

The blocking signal is evaluated at the start of each program cycle. The blocking signals are connected to the function's dedicated input, which can be configured in the *IO* → *Blocking Input Control* tab of the function.

- When the pick-up element activates and the blocking signal is not active, a START signal is generated, and the function starts or continues with the trip time countdown.
- When the pick-up element activates and the blocking signal is active, a BLOCKED signal is generated, and the function does not process the event further.
- When a START signal is already active and the blocking input signal becomes active, the START signal is reset and BLOCKED signal is generated. The release time characteristics are then processed in the same way as when the pick-up signal is reset.

The blocking signal needs to reach the device minimum of 5 ms before the set operating delay has passed in order for the blocking to activate in time.

## Operating time characteristics for trip and reset

The operating timers' behavior during a function can be set for TRIP signal and also for the release of the function in case the pick-up element is reset before the trip time has been reached. There are three basic operating modes available for the function:

- Instant operation: gives the TRIP signal with no additional time delay simultaneously with the START signal.

- Definite time operation (DT): gives the TRIP signal after a user-defined time delay regardless of the measured voltage as long as the voltage is above the  $U_{set}$  value and thus the pick-up element is active (independent time characteristics).
- Inverse definite minimum time (IDMT): gives the TRIP signal after a time which is in relation to the set pick-up voltage  $U_{set}$  and the measured voltage  $U_m$  (dependent time characteristics).

The IDMT function follows this formula:

$$t = \frac{k}{\left(\frac{U_m}{U_s}\right)^a - 1}$$

Where:

- $t$  = operating time
- $k$  = time dial setting
- $U_m$  = measured voltage
- $U_s$  = pick-up setting
- $a$  = IDMT Multiplier setting

The following table presents the setting parameters for the function's time characteristics.

Table. 4.4.9 - 110. Setting parameters for operating time characteristics.

| Name                          | Range  | Step   | Default | Description   |
|-------------------------------|--|--------|---------|---|
| Delay type                    | <ul style="list-style-type: none"> <li>• DT</li> <li>• IDMT</li> </ul> | -      | DT      | Selection of the delay type time counter. The selection possibilities are dependent (IDMT, Inverse Definite Minimum Time) and independent (DT, Definite Time) characteristics.  |
| Definite operating time delay | 0.000...800.000s   | 0.005s | 0.040s  | Definite time operating delay. The setting is active and visible when DT is the selected delay type.<br>When set to 0.000 s, the stage operates as instant stage without added delay. When the parameter is set to 0.005...1800 s, the stage operates as independent delayed. |
| Time dial setting k           | 0.01...60.00s  | 0.01s  | 0.05s   | This setting is active and visible when IDMT is the selected delay type.<br>Time dial/multiplier setting for IDMT characteristics.  |
| IDMT Multiplier               | 0.01...25.00s  | 0.01s  | 1.00s   | This setting is active and visible when IDMT is the selected delay type.<br>IDMT time multiplier in the $U_m/U_{set}$ power.  |

Table. 4.4.9 - 111. Setting parameters for reset time characteristics.

| Name                    | Range   | Step   | Default | Description   |
|-------------------------|---|--------|---------|---|
| Release time delay      | 0.000...150.000s  | 0.005s | 0.06s   | Resetting time. The time allowed between pick-ups if the pick-up has not led to a trip operation. During this time the START signal is held on for the timers if the delayed pick-up release is active. |
| Delayed pick-up release | <ul style="list-style-type: none"> <li>• No</li> <li>• Yes</li> </ul> | -      | Yes     | Resetting characteristics selection either as time-delayed or as instant after the pick-up element is released. If activated the START signal is reset after the set release time delay.                |

| Name  | Range   | Step | Default | Description  |
|---|---|------|---------|--|
| Time calc reset after release time            | <ul style="list-style-type: none"> <li>No</li> <li>Yes</li> </ul> | -    | Yes     | Operating timer resetting characteristics selection. When active, the operating time counter is reset after a set release time if the pick-up element is not activated during this time. When disabled, the operating time counter is reset directly after the pick-up element is reset. |
| Continue time calculation during release time | <ul style="list-style-type: none"> <li>No</li> <li>Yes</li> </ul> | -    | No      | Time calculation characteristics selection. If activated, the operating time counter is continuing until a set release time has passed even if the pick-up element is reset.   |

## Events and registers

The overvoltage function (abbreviated "OV" in event block names) generates events and registers from the status changes in the events listed below. The user can select which event messages are stored in the main event buffer: ON, OFF, or both. The events triggered by the function are recorded with a time stamp.

The function's outputs can be used for direct I/O controlling and user logic programming. The function also provides a resettable cumulative counter for the START, TRIP and BLOCKED events.

The function offers four (4) independent stages; the events are segregated for each stage operation.

Table. 4.4.9 - 112. Event messages.

| Event block name | Event names  |
|------------------|--------------|
| OV1...OV4        | Start ON/OFF |
| OV1...OV4        | Trip ON/OFF  |
| OV1...OV4        | Block ON/OFF |

The function registers its operation into the last twelve (12) time-stamped registers; this information is available for all provided instances separately. The register of the function records the ON event process data for START, TRIP or BLOCKED. The table below presents the structure of the function's register content.

Table. 4.4.9 - 113. Register content.

| Register            | Description              |
|---------------------|--------------------------|
| Date and time       | dd.mm.yyyy hh:mm:ss.mss  |
| Event               | Event name               |
| Fault type          | L1-G...L1-L2-L3          |
| Pre-trigger voltage | Start/Trip -20ms voltage |
| Pre-fault voltage   | Start -200ms voltage     |
| Trip time remaining | 0 ms...1800s             |

| Register | Description                |
|----------|----------------------------|
| Used SG  | Setting group 1...8 active |

### 4.4.10 Undervoltage protection (U<; 27)

The undervoltage function is used for instant and time-delayed undervoltage protection. Devices with a voltage protection module has four (4) available stages of the function (U>, U>>, U>>>, U>>>>). The function constantly measures phase voltage magnitudes or line-to-line voltage magnitudes. Undervoltage protection has two blocking stages: internal blocking (based on voltage measurement and low voltage), or external blocking (e.g. during voltage transformer fuse failure).

Figure. 4.4.10 - 59. Simplified function block diagram of the U< function.

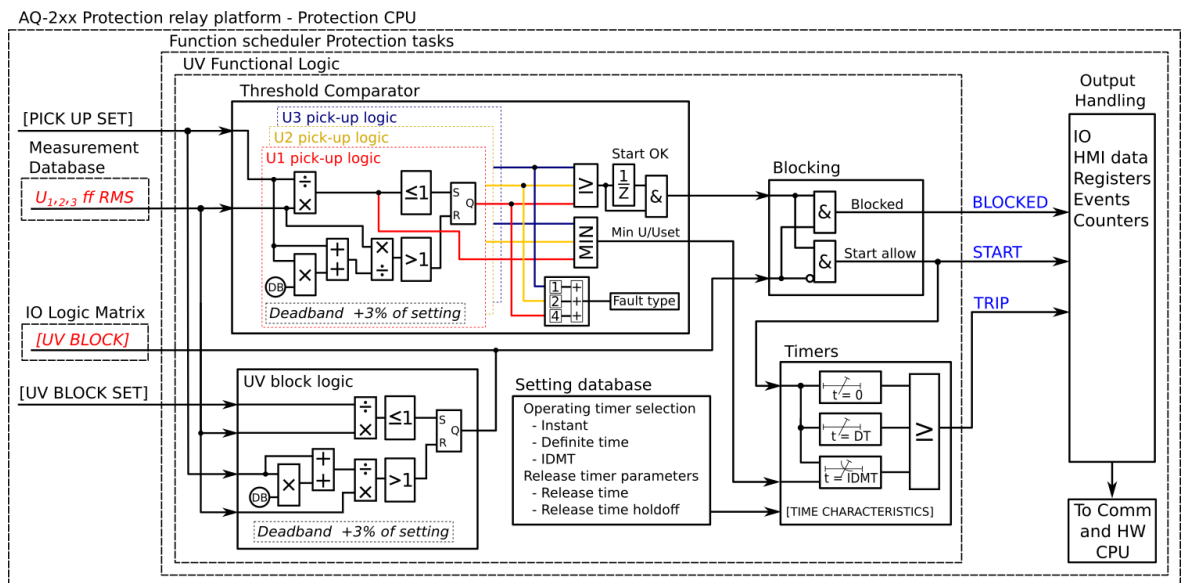

### Measured input

The function block uses fundamental frequency component of line-to-line or line-to-neutral (as the user selects). If the protection is based on line-to-line voltage, undervoltage protection is not affected by earth faults in isolated or compensated networks.

Table. 4.4.10 - 114. Measurement input of the U> function.

| Signal               | Description  |
|----------------------|--|
| U <sub>L12</sub> RMS | Fundamental frequency component of U <sub>L12</sub> /V voltage measurement |
| U <sub>L23</sub> RMS | Fundamental frequency component of U <sub>L23</sub> /V voltage measurement |
| U <sub>L31</sub> RMS | Fundamental frequency component of U <sub>L31</sub> /V voltage measurement |
| U <sub>L1</sub> RMS  | Fundamental frequency component of U <sub>L1</sub> /V voltage measurement  |
| U <sub>L2</sub> RMS  | Fundamental frequency component of U <sub>L2</sub> /V voltage measurement  |
| U <sub>L3</sub> RMS  | Fundamental frequency component of U <sub>L3</sub> /V voltage measurement  |

Table. 4.4.10 - 115. Measured magnitude selection settings.

| Name               | Range  | Default      | Description   |
|--------------------|--|--------------|---|
| Measured magnitude | <ul style="list-style-type: none"> <li>P-P voltages</li> <li>P-E voltages</li> <li>U3 input (2LL-U3SS)</li> <li>U4 input (SS)</li> </ul> | P-P voltages | Selection of P-P or P-E voltages. Additionally, the U3 or U4 input can be assigned as the voltage channel to be supervised. |

Figure. 4.4.10 - 60. Selectable measurement magnitudes with 3LN+U4 VT connection.

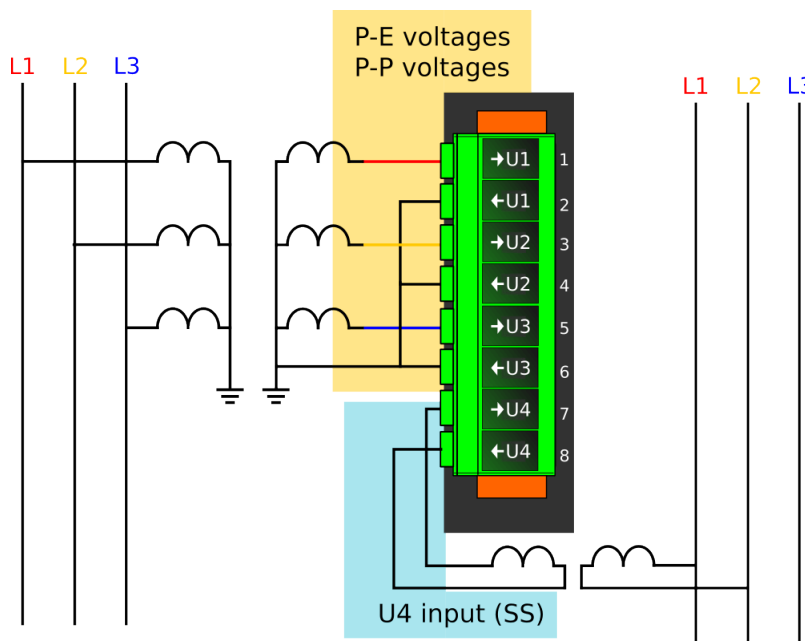

Figure. 4.4.10 - 61. Selectable measurement magnitudes with 3LL+U4 VT connection (P-E voltages not available without residual voltage).

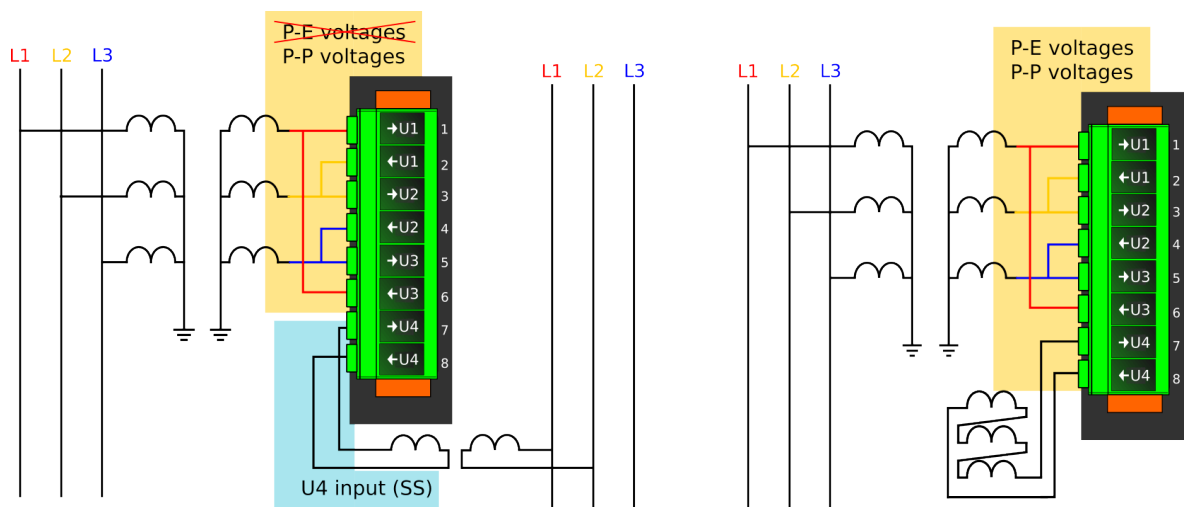
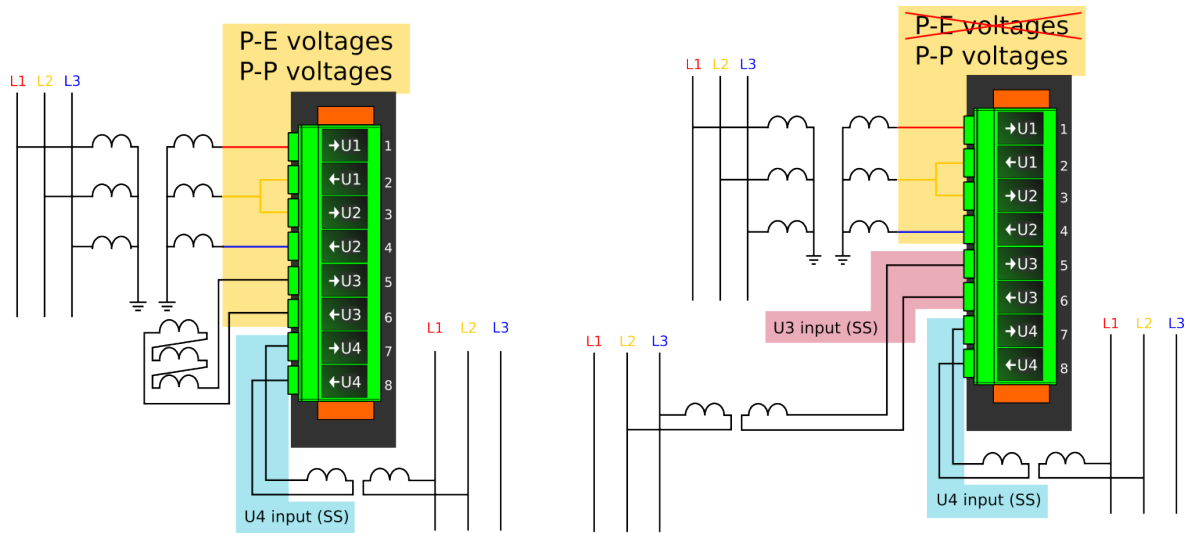

Figure. 4.4.10 - 62. Selectable measurement magnitudes with 2LL+U4 VT connection (P-E voltages not available without residual voltage).



*P-P Voltages* and *P-E Voltages* selections follow phase-to-neutral or phase-to-phase voltages in the first three voltage channels (or two first voltage channels in the 2LL+U3+U4 mode). *U4 input* selection follows the voltage in Channel 4. *U3Input* selection only follows the voltage in Channel 3 if the 2LL+U3+U4 mode is in use.

### General settings

The following general settings define the general behavior of the function. These settings are static i.e. it is not possible to change them by editing the setting group.

Table. 4.4.10 - 116. General settings of the function.

| Name               | Range  | Default | Description   |
|--------------------|--|---------|---|
| U< LN mode         | <ul style="list-style-type: none"> <li>On</li> <li>Blocked</li> <li>Test</li> <li>Test/Blocked</li> <li>Off</li> </ul> | On      | Set mode of UV block. This parameter is visible only when <i>Allow setting of individual LN mode</i> is enabled in <i>General</i> menu. |
| U< force status to | <ul style="list-style-type: none"> <li>Normal</li> <li>Start</li> <li>Trip</li> <li>Blocked</li> </ul>                 | Normal  | Force the status of the function. Visible only when <i>Enable stage forcing</i> parameter is enabled in <i>General</i> menu.            |

### Pick-up settings

The  $U_{set}$  setting parameter controls the pick-up of the U< function. This defines the minimum allowed measured voltage before action from the function. The function constantly calculates the ratio between the  $U_{set}$  and the measured magnitude ( $U_m$ ) for each of the three voltages. The reset ratio of 103 % is built into the function and is always relative to the  $U_{set}$  value. The setting value is common for all measured amplitudes, and when the  $U_m$  exceeds the  $U_{set}$  value (in single, dual or all voltages) it triggers the pick-up operation of the function.

Setting group selection controls the operating characteristics of the function, i.e. the user or user-defined logic can change function parameters while the function is running.

Table. 4.4.10 - 117. Pick-up settings.

| Name            | Range                | Step        | Default   | Description  |
|-----------------|----------------------|-------------|-----------|--|
| $U_{set}$       | 0.00...120.00% $U_n$ | 0.01% $U_n$ | 60% $U_n$ | Pick-up setting  |
| U Block setting | 0.00...100.00% $U_n$ | 0.01% $U_n$ | 10% $U_n$ | Block setting. If set to zero, blocking is not in use. The operation is explained in the next chapter. |

### Using *Block setting* to prevent nuisance trips

It is recommended to use the *Block setting* parameter to prevent the device from tripping in a situation where the network is de-energized. When the measured voltage drops below the set value, the device does not give a tripping signal. If the measured voltage has dropped below the *Block setting* parameter, the blocking continues until all of the line voltages have increased above the  $U_{<}$  pick-up setting. Please see the image below for a visualization of this function. If the block level is set to zero (0), blocking is not in use.

Figure. 4.4.10 - 63. Example of the block setting operation.

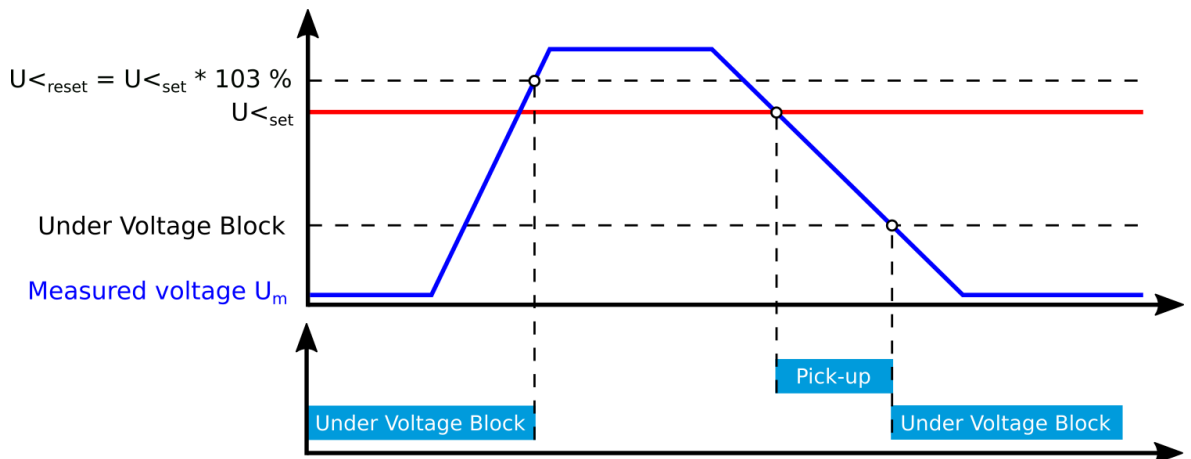

### Read-only parameters

The function's *Info* page displays useful, real-time information on the state of the protection function. It is accessed either through the device's HMI display, or through the setting tool software when it is connected to the device and its Live Edit mode is active.

Table. 4.4.10 - 118. Information displayed by the function.

| Name                    | Range  | Step | Description   |
|-------------------------|--|------|---|
| $U_{<}$ LN behaviour    | <ul style="list-style-type: none"> <li>On</li> <li>Blocked</li> <li>Test</li> <li>Test/Blocked</li> <li>Off</li> </ul> | -    | Displays the mode of UV block. This parameter is visible only when <i>Allow setting of individual LN mode</i> is enabled in <i>General</i> menu.    |
| $U_{<}$ pick-up setting | 0.0...1 000 000.0V   | 0.1V | The primary voltage required for tripping. The displayed pick-up voltage level depends on the pick-up setting and the voltage transformer settings. |

| Name   | Range                        | Step               | Description  |
|--|------------------------------|--------------------|--|
| U< block setting                               | 0.0...1 000 000.0V           | 0.1V               | The primary voltage level required for trip blocking. If the measured voltage is below this value, the network is considered de-energized and the function will not trip. To deactivate the blocking the measured voltage must exceed the pick-up setting value. |
| Expected operating time                        | 0.000...1800.000s            | 0.005s             | Displays the expected operating time when a fault occurs. When IDMT mode is used, the expected operating time depends on the measured voltage value. If the measured voltage changes during a fault, the expected operating time changes accordingly.            |
| Time remaining to trip                         | -1800.000...1800.000s        | 0.005s             | When the function has detected a fault and counts down time towards a trip, this displays how much time is left before tripping occurs.  |
| $U_{A(B)}$<br>meas/ $U_{set}$<br>at the moment | 0.00...1250.00 $U_m/U_{set}$ | 0.01 $U_m/U_{set}$ | The ratio between $U_A$ or $U_{AB}$ voltage and the pick-up value.   |
| $U_{B(c)}$<br>meas/ $U_{set}$<br>at the moment | 0.00...1250.00 $U_m/U_{set}$ | 0.01 $U_m/U_{set}$ | The ratio between $U_B$ or $U_{BC}$ voltage and the pick-up value.   |
| $U_{C(A)}$<br>meas/ $U_{set}$<br>at the moment | 0.00...1250.00 $U_m/U_{set}$ | 0.01 $U_m/U_{set}$ | The ratio between $U_C$ or $U_{CA}$ voltage and the pick-up value.   |
| $U_{meas}/U_{set}$<br>at the moment            | 0.00...1250.00 $U_m/U_{set}$ | 0.01 $U_m/U_{set}$ | The ratio between the lowest measured phase or line voltage and the pick-up value.   |

## Function blocking

The blocking signal is evaluated at the start of each program cycle. The blocking signals are connected to the function's dedicated input, which can be configured in the *IO* → *Blocking Input Control* tab of the function.

- When the pick-up element activates and the blocking signal is not active, a START signal is generated, and the function starts or continues with the trip time countdown.
- When the pick-up element activates and the blocking signal is active, a BLOCKED signal is generated, and the function does not process the event further.
- When a START signal is already active and the blocking input signal becomes active, the START signal is reset and BLOCKED signal is generated. The release time characteristics are then processed in the same way as when the pick-up signal is reset.

The blocking signal needs to reach the device minimum of 5 ms before the set operating delay has passed in order for the blocking to activate in time.

## Operating time characteristics for trip and reset

The operating timers' behavior during a function can be set for TRIP signal and also for the release of the function in case the pick-up element is reset before the trip time has been reached. There are three basic operating modes available for the function:

- Instant operation: gives the TRIP signal with no additional time delay simultaneously with the START signal.
- Definite time operation (DT): gives the TRIP signal after a user-defined time delay regardless of the measured voltage as long as the voltage is above the  $U_{set}$  value and thus the pick-up element is active (independent time characteristics).
- Inverse definite minimum time (IDMT): gives the TRIP signal after a time which is in relation to the set pick-up voltage  $U_{set}$  and the measured voltage  $U_m$  (dependent time characteristics).

The IDMT function follows this formula:

$$t = \frac{k}{1 - \left(\frac{U_m}{U_s}\right)^a}$$

Where:

- $t$  = operating time
- $k$  = time dial setting
- $U_m$  = measured voltage
- $U_s$  = pick-up setting
- $a$  = IDMT multiplier setting

The following table presents the setting parameters for the function's time characteristics.

Table. 4.4.10 - 119. Setting parameters for operating time characteristics.

| Name                          | Range  | Step   | Default | Description   |
|-------------------------------|--|--------|---------|---|
| Delay type                    | <ul style="list-style-type: none"> <li>• DT</li> <li>• IDMT</li> </ul> | -      | DT      | Selection of the delay type time counter. The selection possibilities are dependent (IDMT, Inverse Definite Minimum Time) and independent (DT, Definite Time) characteristics.  |
| Definite operating time delay | 0.000...1800.000s  | 0.005s | 0.040s  | Definite time operating delay. This setting is active and visible when DT is the selected delay type. When set to 0.000 s, the stage operates as instant stage without added delay. When the parameter is set to 0.005...1800 s, the stage operates as independent delayed. |
| Time dial setting k           | 0.01...60.00s  | 0.01s  | 0.05s   | This setting is active and visible when IDMT is the selected delay type. Time dial/multiplier setting for IDMT characteristics.   |
| IDMT Multiplier               | 0.01...25.00s  | 0.01s  | 1.00s   | This setting is active and visible when IDMT is the selected delay type. IDMT time multiplier in the $U_m/U_{set}$ power.   |

Table. 4.4.10 - 120. Setting parameters for reset time characteristics.

| Name               | Range            | Step   | Default | Description   |
|--------------------|------------------|--------|---------|---|
| Release time delay | 0.000...150.000s | 0.005s | 0.06s   | Resetting time. The time allowed between pick-ups if the pick-up has not led to a trip operation. During this time the START signal is held on for the timers if the delayed pick-up release is active. |

| Name  | Range   | Step | Default | Description  |
|---|---|------|---------|--|
| Delayed pick-up release                       | <ul style="list-style-type: none"> <li>No</li> <li>Yes</li> </ul> | -    | Yes     | Resetting characteristics selection, either time-delayed or instant after the pick-up element is released. If activated, the START signal is reset after a set release time delay.   |
| Time calc reset after release time            | <ul style="list-style-type: none"> <li>No</li> <li>Yes</li> </ul> | -    | Yes     | Operating timer resetting characteristics selection. When activated, the operating time counter is reset after a set release time if the pick-up element is not activated during this time. When disabled, the operating time counter is reset directly after the pick-up element reset. |
| Continue time calculation during release time | <ul style="list-style-type: none"> <li>No</li> <li>Yes</li> </ul> | -    | No      | Time calculation characteristics selection. If activated, the operating time counter continues until a set release time even when the pick-up element is reset.  |

## Events and registers

The undervoltage function (abbreviated "UV" in event block names) generates events and registers from the status changes in the events listed below. The user can select which event messages are stored in the main event buffer: ON, OFF, or both. The events triggered by the function are recorded with a time stamp.

The function's outputs can be used for direct I/O controlling and user logic programming. The function also provides a resettable cumulative counter for the START, TRIP and BLOCKED events.

The function offers four (4) independent stages; the events are segregated for each stage operation.

Table. 4.4.10 - 121. Event messages.

| Event block name | Event names               |
|------------------|---------------------------|
| UV1...UV4        | Start ON/OFF              |
| UV1...UV4        | Trip ON/OFF               |
| UV1...UV4        | Block ON/OFF              |
| UV1...UV4        | Undervoltage Block ON/OFF |

The function registers its operation into the last twelve (12) time-stamped registers; this information is available for all provided instances separately. The register of the function records the ON event process data for START, TRIP or BLOCKED. The table below presents the structure of the function's register content.

Table. 4.4.10 - 122. Register content.

| Register      | Description             |
|---------------|-------------------------|
| Date and time | dd.mm.yyyy hh:mm:ss.mss |
| Event         | Event name              |
| Fault type    | A...A-B-C               |

| Register            | Description                |
|---------------------|----------------------------|
| Pre-trigger voltage | Start/Trip -20ms voltage   |
| Fault voltage       | Start/Trip voltage         |
| Pre-fault voltage   | Start -200ms voltage       |
| Trip time remaining | 0 ms...1800s               |
| Used SG             | Setting group 1...8 active |

### 4.4.11 Neutral overvoltage protection (U<sub>0</sub>>; 59N)

The neutral overvoltage function is used for non-directional instant and time-delayed earth fault protection.

Below is the formula for symmetric component calculation (and therefore to zero sequence voltage calculation).

$$U_0 = 1/3(U_{L1} + U_{L2} + U_{L3})$$

$$U_{L1...3} = \text{Line to neutral voltages}$$

Below are some examples of zero sequence calculation.

Figure. 4.4.11 - 64. Normal situation.

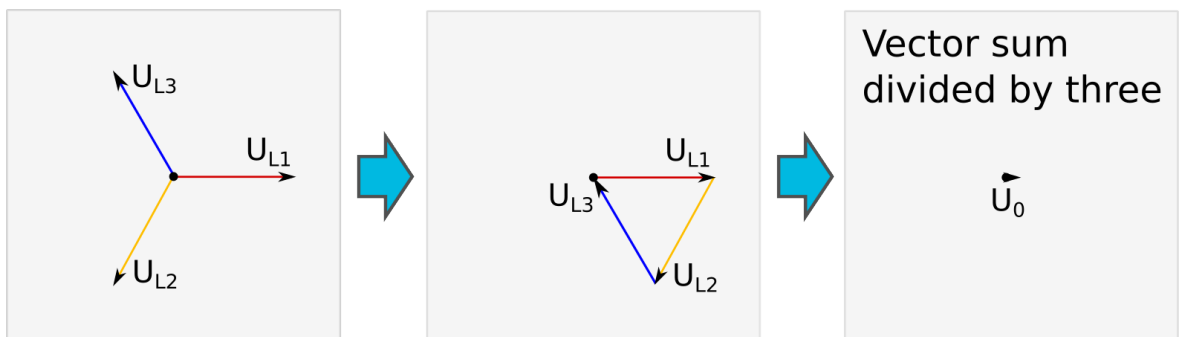

Figure. 4.4.11 - 65. Earth fault in isolated network.

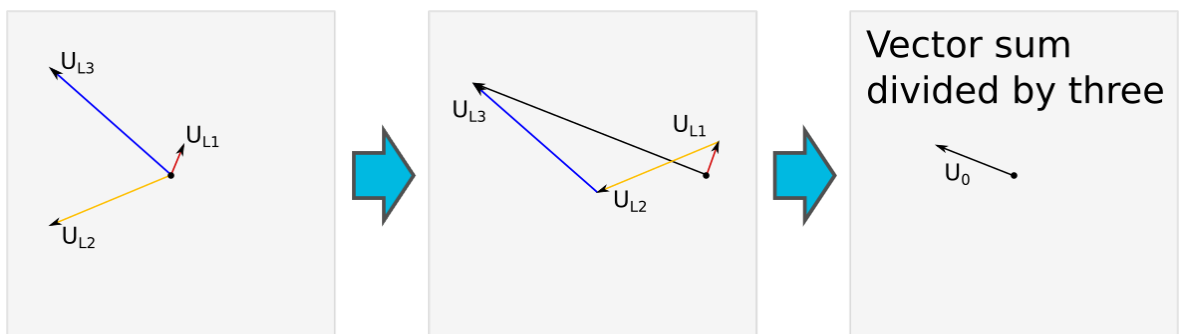

Figure. 4.4.11 - 66. Close-distance short-circuit between phases 1 and 3.

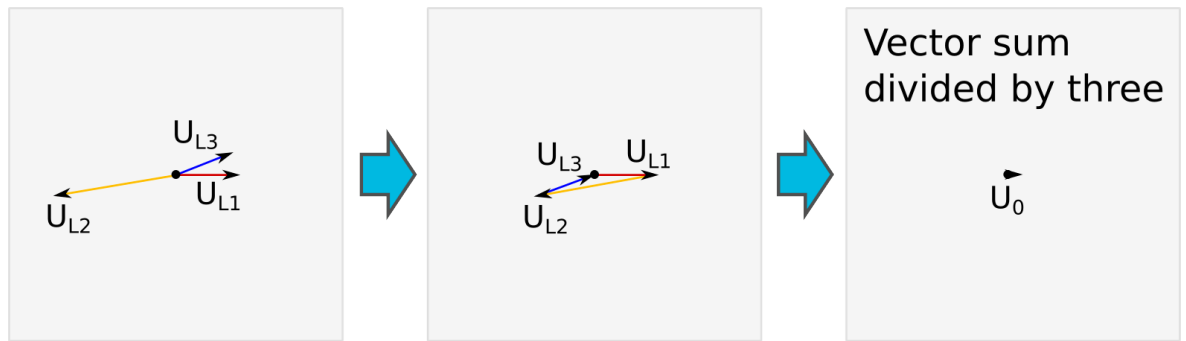
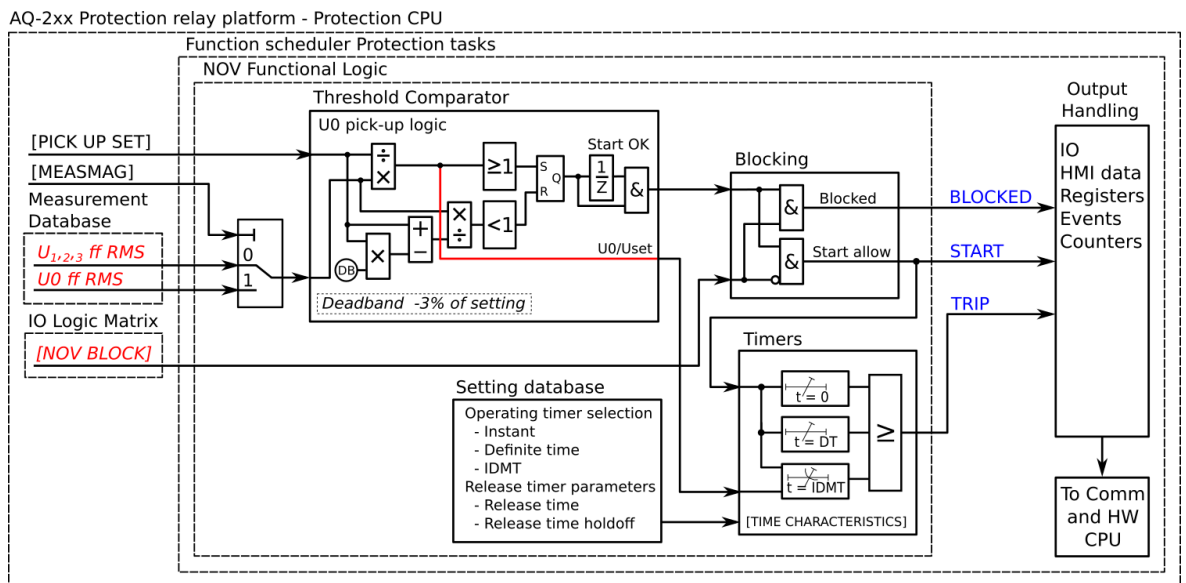

Figure. 4.4.11 - 67. Simplified function block diagram of the U0> function.



### Measured input

The function block uses phase-to-neutral voltage magnitudes or calculated zero sequence component (as the user selects). Neutral overvoltage protection is scaled to line-to-line RMS level. When the line-to-line voltage of a system is 100 V in the secondary side, the earth fault is 100 % of the  $U_n$  and the calculated zero sequence voltage reaches  $100/\sqrt{3} \text{ V} = 57.74 \text{ V}$ .

The selection of the used measurement channel is made with a setting parameter.

Table. 4.4.11 - 123. Measurement inputs of the U0> function.

| Signal             | Description   |
|--------------------|---|
| $U_0\text{RMS}$    | Fundamental frequency component of $U_0/V$ voltage measurement    |
| $U_{L1}\text{RMS}$ | Fundamental frequency component of $U_{L1}/V$ voltage measurement |
| $U_{L2}\text{RMS}$ | Fundamental frequency component of $U_{L2}/V$ voltage measurement |
| $U_{L3}\text{RMS}$ | Fundamental frequency component of $U_{L3}/V$ voltage measurement |

## General settings

The following general settings define the general behavior of the function. These settings are static i.e. it is not possible to change them by editing the setting group.

Table. 4.4.11 - 124. General settings of the function.

| Name                  | Range  | Default | Description  |
|-----------------------|--|---------|--|
| U0> LN mode           | <ul style="list-style-type: none"> <li>On</li> <li>Blocked</li> <li>Test</li> <li>Test/Blocked</li> <li>Off</li> </ul> | On      | Set mode of NOV block.<br>This parameter is visible only when <i>Allow setting of individual LN mode</i> is enabled in <i>General</i> menu.  |
| U0> force status to   | <ul style="list-style-type: none"> <li>Normal</li> <li>Start</li> <li>Trip</li> <li>Blocked</li> </ul>                 | Normal  | Force the status of the function. Visible only when <i>Enable stage forcing</i> parameter is enabled in <i>General</i> menu.   |
| U0> meas input select | <ul style="list-style-type: none"> <li>Select</li> <li>U0Calc</li> <li>U3 Input</li> <li>U4 Input</li> </ul>           | Select  | Defines which available measured magnitude is used by the function.<br>U0Calc calculates the voltage from phase voltages.<br>Please note that U3 Input and U4 Input selections are available only if the channel has been set to U0 mode at <i>Measurements</i> → <i>Transformers</i> → <i>VT module</i> . |

## Pick-up settings

The  $U_{set}$  setting parameter controls the pick-up of the U0> function. This defines the maximum allowed measured voltage before action from the function. The function constantly calculates the ratio between the  $U_{set}$  and the measured magnitude ( $U_m$ ) for neutral voltage. The reset ratio of 97 % is built into the function and is always relative to the  $U_{set}$  value. The setting value is common for all measured amplitudes, and when the  $U_m$  exceeds the  $U_{set}$  value it triggers the pick-up operation of the function.

Setting group selection controls the operating characteristics of the function, i.e. the user or user-defined logic can change function parameters while the function is running.

Table. 4.4.11 - 125. Pick-up settings.

| Name                   | Range                       | Step                | Default              | Description     |
|------------------------|-----------------------------|---------------------|----------------------|-----------------|
| Pick-up setting U0set> | 1.00...99.00%U <sub>n</sub> | 0.01%U <sub>n</sub> | 20.00%U <sub>n</sub> | Pick-up setting |

## Read-only parameters

The function's *Info* page displays useful, real-time information on the state of the protection function. It is accessed either through the device's HMI display, or through the setting tool software when it is connected to the device and its Live Edit mode is active.

| Name                             | Range  | Step   | Description   |
|----------------------------------|--|--------|---|
| U0> LN mode behaviour            | <ul style="list-style-type: none"> <li>On</li> <li>Blocked</li> <li>Test</li> <li>Test/Blocked</li> <li>Off</li> </ul> | -      | Displays the mode of NOV block. This parameter is visible only when <i>Allow setting of individual LN mode</i> is enabled in <i>General</i> menu.   |
| U0> Measuring now                | <ul style="list-style-type: none"> <li>No U0 avail!</li> <li>U0Calc</li> <li>U3 Input</li> <li>U4 Input</li> </ul>     | -      | Displays which voltage channel is used by the function. If no voltage channel has been selected the function defaults to calculated residual voltage if line-to-neutral voltages have been connected to device. If no channel is set to "U0" mode and line-to-line voltages are connected, no residual voltage is available and "No U0 avail!" will be displayed. |
| U0> Pick-up setting              | 0.0...1 000 000.0V   | 0.1V   | Primary voltage required for tripping. The displayed pick-up voltage level depends on the chosen U0 measurement input selection, on the pick-up settings and on the voltage transformer settings.   |
| Expected operating time          | 0.000...1800.000s  | 0.005s | Displays the expected operating time when a fault occurs. When IDMT mode is used, the expected operating time depends on the measured voltage value. If the measured voltage changes during a fault, the expected operating time changes accordingly.   |
| Time remaining to trip           | -1800.000...1800.000s  | 0.005s | When the function has detected a fault and counts down time towards a trip, this displays how much time is left before tripping occurs.   |
| $U_{meas}/U_{set}$ at the moment | 0.00...1250.00   | 0.01   | The ratio between the measured or calculated neutral voltage and the pick-up value.   |

## Function blocking

The blocking signal is evaluated at the start of each program cycle. The blocking signals are connected to the function's dedicated input, which can be configured in the *IO* → *Blocking Input Control* tab of the function.

- When the pick-up element activates and the blocking signal is not active, a START signal is generated, and the function starts or continues with the trip time countdown.
- When the pick-up element activates and the blocking signal is active, a BLOCKED signal is generated, and the function does not process the event further.
- When a START signal is already active and the blocking input signal becomes active, the START signal is reset and BLOCKED signal is generated. The release time characteristics are then processed in the same way as when the pick-up signal is reset.

The blocking signal needs to reach the device minimum of 5 ms before the set operating delay has passed in order for the blocking to activate in time.

## Operating time characteristics for trip and reset

The operating timers' behavior during a function can be set for TRIP signal and also for the release of the function in case the pick-up element is reset before the trip time has been reached. There are three basic operating modes available for the function:

- Instant operation: gives the TRIP signal with no additional time delay simultaneously with the START signal.

- Definite time operation (DT): gives the TRIP signal after a user-defined time delay regardless of the measured or calculated voltage as long as the voltage is above the  $U_{set}$  value and thus the pick-up element is active (independent time characteristics).
- Inverse definite minimum time (IDMT): gives the TRIP signal after a time which is in relation to the set pick-up voltage  $U_{set}$  and the measured voltage  $U_m$  (dependent time characteristics).

The IDMT function follows this formula:

$$t = \frac{k}{\left(\frac{U_m}{U_s}\right)^a - 1}$$

Where:

- $t$  = operating time
- $k$  = time dial setting
- $U_m$  = measured voltage
- $U_s$  = pick-up setting
- $a$  = IDMT multiplier setting

The following table presents the setting parameters for the function's time characteristics.

Table. 4.4.11 - 126. Setting parameters for operating time characteristics.

| Name                          | Range             | Step   | Default | Description   |
|-------------------------------|-------------------|--------|---------|---|
| Delay type                    | DT<br>IDMT        | -      | DT      | Selection of the delay type time counter. The selection possibilities are dependent (IDMT, Inverse Definite Minimum Time) and independent (DT, Definite Time) characteristics.  |
| Definite operating time delay | 0.000...1800.000s | 0.005s | 0.040s  | Definite time operating delay. The setting is active and visible when DT is the selected delay type.<br>When set to 0.000 s, the stage operates as instant without added delay. When the parameter is set to 0.005...1800 s, the stage operates as independent delayed. |
| Time dial setting k           | 0.01...60.00s     | 0.01s  | 0.05s   | The setting is active and visible when IDMT is the selected delay type.<br>Time dial/multiplier setting for IDMT characteristics.   |
| IDMT Multiplier               | 0.01...25.00s     | 0.01s  | 1.00s   | The setting is active and visible when IDMT is the selected delay type.<br>IDMT time multiplier in the $U_m/U_{set}$ power.   |

Table. 4.4.11 - 127. Setting parameters for reset time characteristics.

| Name                    | Range   | Step   | Default | Description   |
|-------------------------|---|--------|---------|---|
| Release time delay      | 0.000...150.000s  | 0.005s | 0.06s   | Resetting time. Time allowed between pick-ups if the pick-up has not led to a trip operation. During this time the START signal is held on for the timers if the delayed pick-up release is active. |
| Delayed pick-up release | <ul style="list-style-type: none"> <li>• No</li> <li>• Yes</li> </ul> | -      | Yes     | Resetting characteristics selection either as time-delayed or as instant after the pick-up element is released. If activated, the START signal is reset after a set release time delay.             |

| Name  | Range   | Step | Default | Description   |
|---|---|------|---------|---|
| Time calc reset after release time            | <ul style="list-style-type: none"> <li>No</li> <li>Yes</li> </ul> | -    | Yes     | Operating timer resetting characteristics selection. When active, the operating time counter is reset after a set release time if the pick-up element is not activated during this time. When disabled, the operating time counter is reset directly after the pick-up element reset. |
| Continue time calculation during release time | <ul style="list-style-type: none"> <li>No</li> <li>Yes</li> </ul> | -    | No      | Time calculation characteristics selection. If activated, the operating time counter continues until a set release time has passed even if the pick-up element is reset.  |

The user can reset characteristics through the application. The default setting is a 60 ms delay; the time calculation is held during the release time.

In the release delay option the operating time counter calculates the operating time during the release. When using this option the function does not trip if the input signal is not re-activated while the release time count is on-going.

## Events and registers

The neutral overvoltage function (abbreviated "NOV" in event block names) generates events and registers from the status changes in the events listed below. The user can select which event messages are stored in the main event buffer: ON, OFF, or both. The events triggered by the function are recorded with a time stamp.

The function's outputs can be used for direct I/O controlling and user logic programming. The function also provides a cumulative counter for the START, TRIP and BLOCKED events.

The function offers four (4) independent stages; the events are segregated for each stage operation.

Table. 4.4.11 - 128. Event messages.

| Event block name | Event names  |
|------------------|--------------|
| NOV1...NOV4      | Start ON/OFF |
| NOV1...NOV4      | Trip ON/OFF  |
| NOV1...NOV4      | Block ON/OFF |

The function registers its operation into the last twelve (12) time-stamped registers; this information is available for all provided instances separately. The register of the function records the ON event process data for START, TRIP or BLOCKED. The table below presents the structure of the function's register content.

Table. 4.4.11 - 129. Register content.

| Register      | Description             |
|---------------|-------------------------|
| Date and time | dd.mm.yyyy hh:mm:ss.mss |
| Event         | Event name              |
| Fault type    | L1-G...L1-L2-L3         |

| Register             | Description                |
|----------------------|----------------------------|
| Pre-trigger voltage  | Start/Trip -20ms voltage   |
| Fault voltage        | Start/Trip voltage         |
| Pre-fault voltage    | Start -200ms voltage       |
| Trip time remaining  | 0 ms...1800s               |
| Setting group in use | Setting group 1...8 active |

#### 4.4.12 Sequence voltage protection (U1/U2>/<; 47/27P/59PN)

The sequence voltage function is used for instant and time-delayed voltage protection. It has positive and negative sequence protection for both overvoltage and undervoltage (the user selects the needed function). The user can select the voltage used. Sequence voltage is based on the system's line-to-line voltage level. Protection stages can be set to protect against either undervoltage or overvoltage.

##### Positive sequence voltage calculation

Below is the formula for symmetric component calculation (and therefore to positive sequence voltage calculation).

$$U_1 = \frac{1}{3}(U_{L1} + aU_{L2} + a^2U_{L3})$$

$$a = 1 \angle 120^\circ$$

$$a^2 = 1 \angle 240^\circ$$

$U_{L1...3}$  = Line to neutral voltages

In what follows are three examples of positive sequence calculation (positive sequence component vector).

Figure. 4.4.12 - 68. Normal situation.

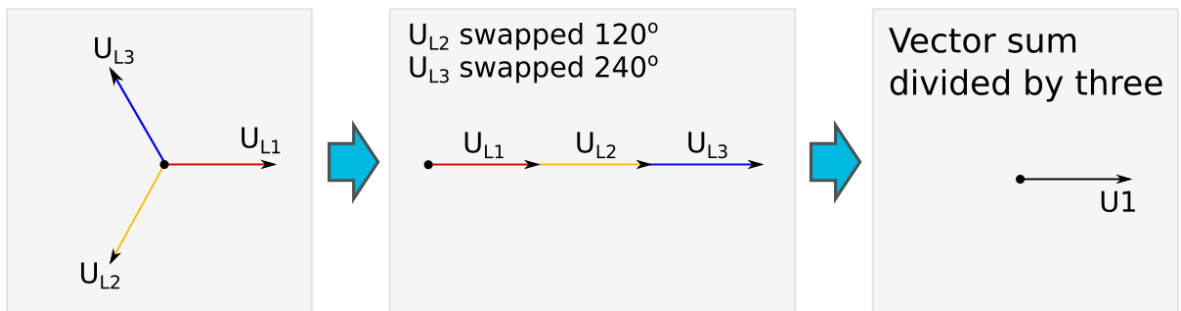

Figure. 4.4.12 - 69. Earth fault in an isolated network.

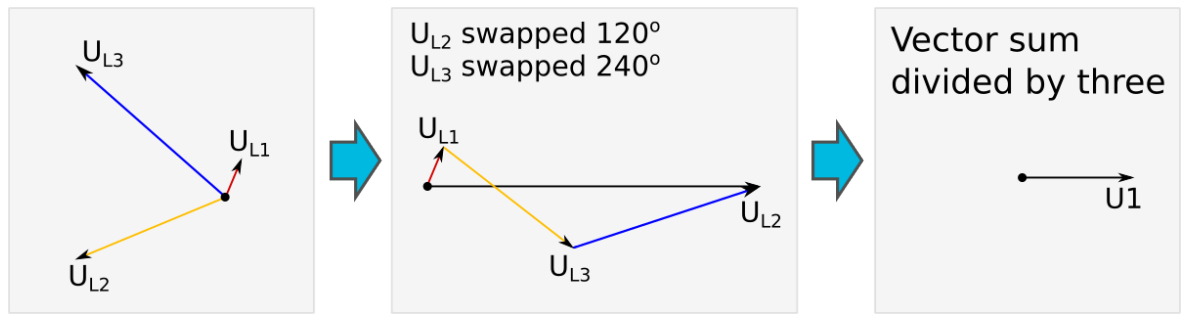
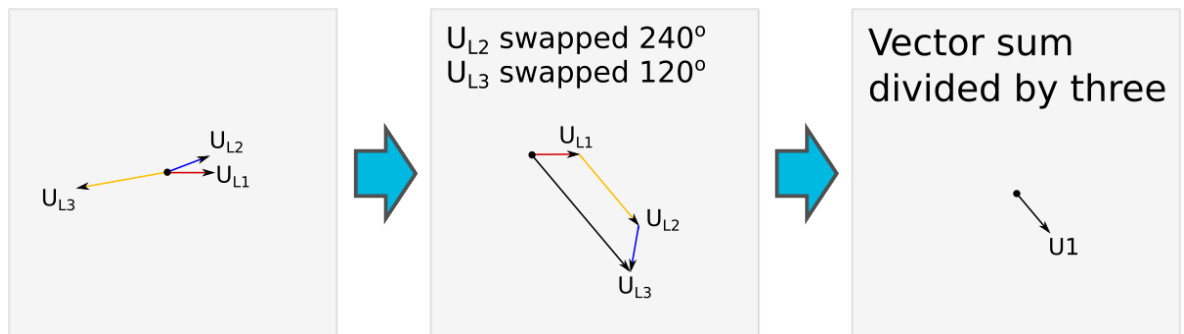

Figure. 4.4.12 - 70. Close-distance short-circuit between phases 1 and 3.



### Negative sequence voltage calculation

Below is the formula for symmetric component calculation (and therefore to negative sequence voltage calculation).

$$U_2 = \frac{1}{3} (U_{L1} + a^2 U_{L2} + a U_{L3})$$

$$a = 1 \angle 120^\circ$$

$$a^2 = 1 \angle 240^\circ$$

$U_{L1...3}$  = Line to neutral voltages

In what follows are three examples of negative sequence calculation (negative sequence component vector).

Figure. 4.4.12 - 71. Normal situation.

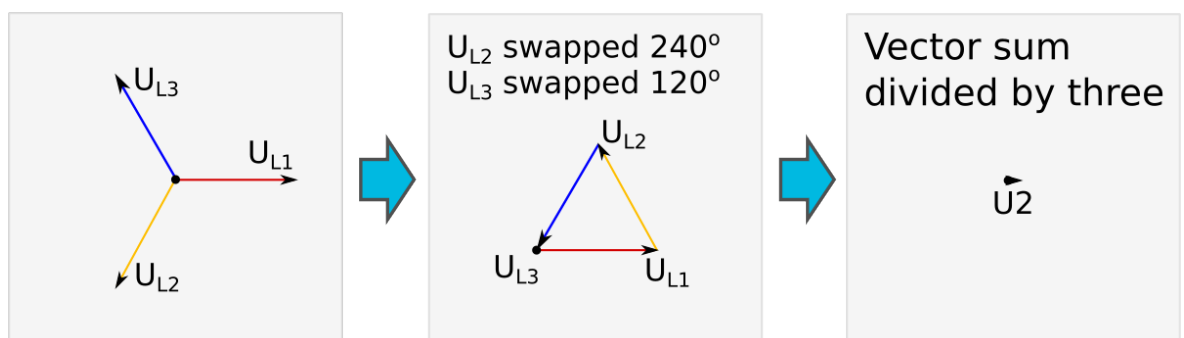

Figure. 4.4.12 - 72. Earth fault in isolated network.

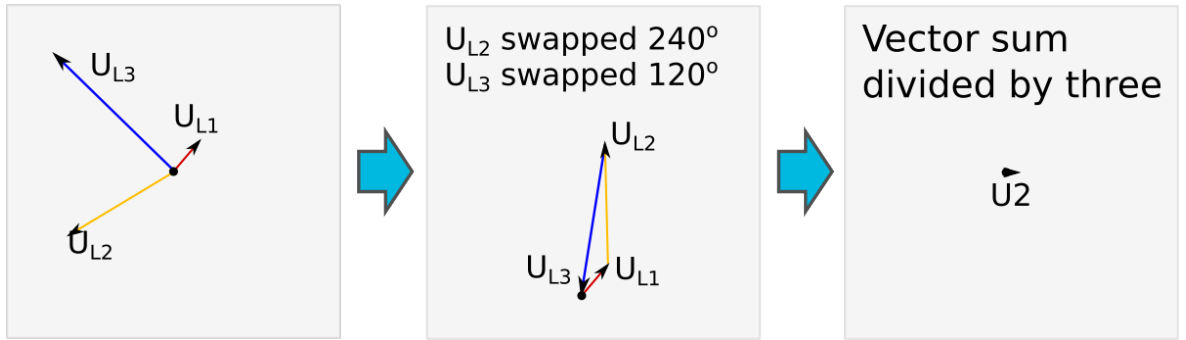

Figure. 4.4.12 - 73. Close-distance short-circuit between phases 1 and 3.

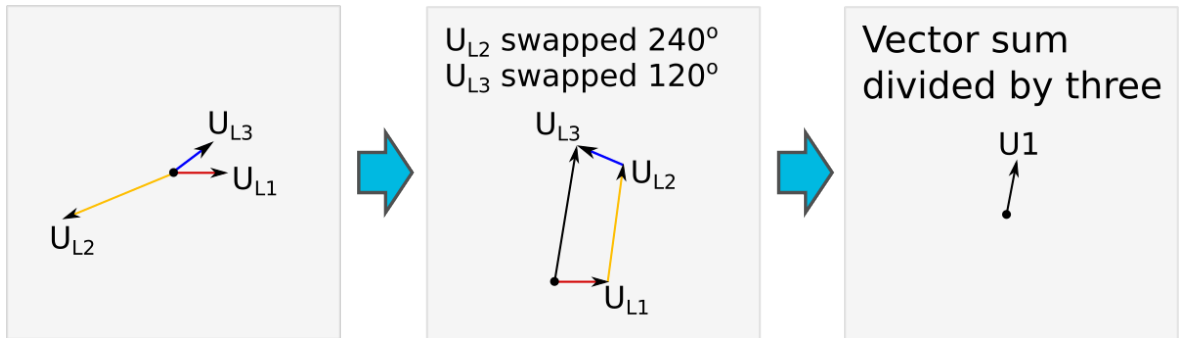
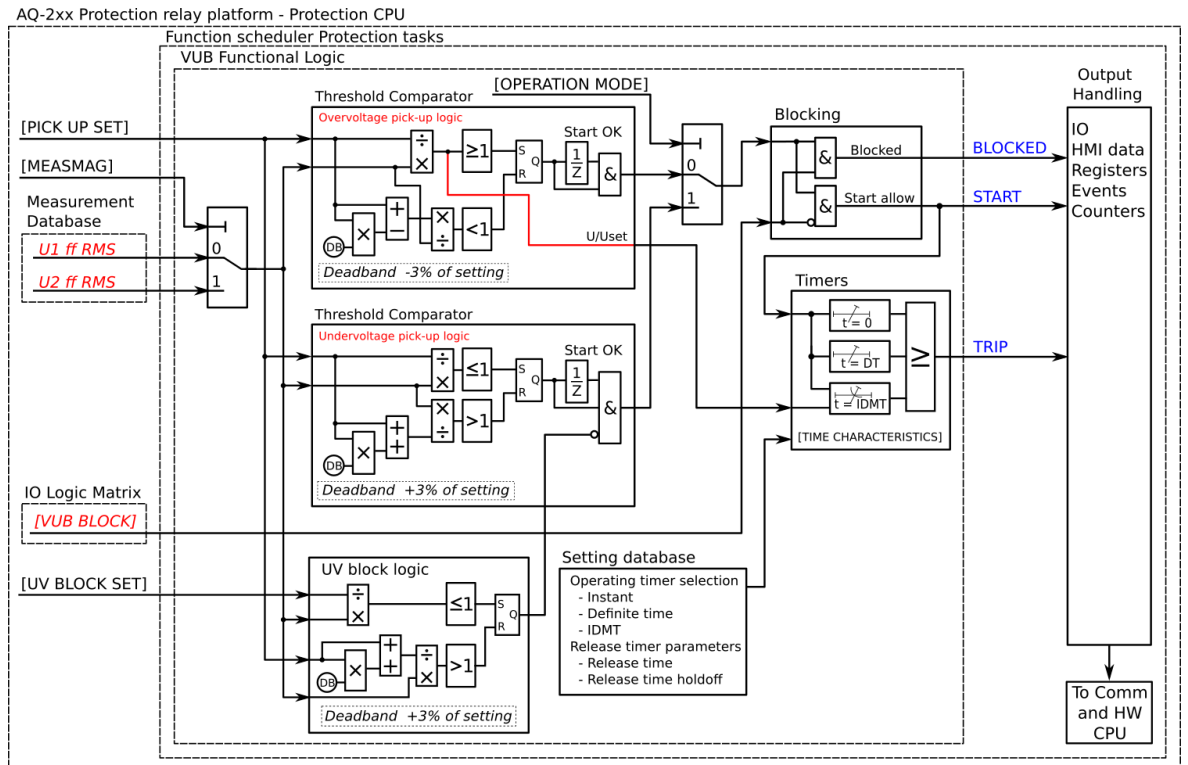

Figure. 4.4.12 - 74. Simplified function block diagram of the U1/U2>/< function.



## Measured input

The function block uses fundamental frequency component of phase-to-phase, phase-to-neutral and zero sequence voltage measurements. The user can select the monitored magnitude to be either positive sequence voltage or negative sequence voltage values.

Table. 4.4.12 - 130. Measurement inputs of the U1/U2>/< function.

| Signal             | Description  |
|--------------------|--|
| U <sub>1</sub> RMS | Fundamental frequency component of U <sub>1</sub> /V voltage channel |
| U <sub>2</sub> RMS | Fundamental frequency component of U <sub>2</sub> /V voltage channel |
| U <sub>3</sub> RMS | Fundamental frequency component of U <sub>3</sub> /V voltage channel |
| U <sub>4</sub> RMS | Fundamental frequency component of U <sub>4</sub> /V voltage channel |

## General settings

The following general settings define the general behavior of the function. These settings are static i.e. it is not possible to change them by editing the setting group.

Table. 4.4.12 - 131. General settings of the function.

| Name                     | Range  | Default                      | Description  |
|--------------------------|--|------------------------------|--|
| U1/2 >/< LN mode         | <ul style="list-style-type: none"> <li>On</li> <li>Blocked</li> <li>Test</li> <li>Test/Blocked</li> <li>Off</li> </ul> | On                           | Set mode of VUB block. This parameter is visible only when <i>Allow setting of individual LN mode</i> is enabled in <i>General</i> menu. |
| U1/2 >/< force status to | <ul style="list-style-type: none"> <li>Normal</li> <li>Start</li> <li>Trip</li> <li>Blocked</li> </ul>                 | Normal                       | Force the status of the function. Visible only when <i>Enable stage forcing</i> parameter is enabled in <i>General</i> menu.             |
| Measured magnitude       | <ul style="list-style-type: none"> <li>U1 Positive sequence voltage</li> <li>U2 Negative sequence voltage</li> </ul>   | U1 Positive sequence voltage | Selects which calculated voltage is supervised.  |

## Pick-up settings

The  $U_{set}$  setting parameter controls the pick-up of the U1/U2>/< function. This defines the maximum or minimum allowed calculated U1 or U2 voltage before action from the function. The function constantly calculates the ratio between the  $U_{set}$  and the calculated U1 or U2 magnitude ( $U_C$ ). The monitored voltage is chosen in the *Info* page with the parameter *Measured magnitude*. The reset ratio of 97 % in overvoltage applications is built into the function and is always relative to the  $U_{set}$  value. The reset ratio of 103 % in undervoltage applications is built into the function and is always relative to the  $U_{set}$  value. When the  $U_C$  goes above or below the  $U_{set}$  value it triggers the pick-up operation of the function.

Setting group selection controls the operating characteristics of the function, i.e. the user or user-defined logic can change function parameters while the function is running.

Table. 4.4.12 - 132. Pick-up settings.

| Name          | Range   | Step        | Default    | Description  |
|---------------|---|-------------|------------|--|
| Pick-up terms | <ul style="list-style-type: none"> <li>Over &gt;</li> <li>Under &lt;</li> </ul> | -           | Over >     | Selects whether the function picks-up when the monitored voltage is under or over the set pick-up value. |
| $U_{set}$     | 5.00...150.00% $U_n$  | 0.01% $U_n$ | 105% $U_n$ | Pick-up setting  |
| $U_{blk}$     | 0.00...80.00% $U_n$   | 0.01% $U_n$ | 5% $U_n$   | Undervoltage blocking (visible when the pick-up term is Under <)   |

### Using *Block setting* to prevent nuisance trips

It is recommended to use the *Under block setting*  $U_{blk}$  parameter when Under < is the chosen tripping condition to prevent the function from tripping in a situation where the network is de-energized. When the measured voltage drops below the set value, the function does not give a tripping signal. If the measured voltage has dropped below the *Under block setting*  $U_{blk}$  parameter, the blocking continues until all of the line voltages have increased above the  $U_{<}$  pick-up setting. Please see the image below for a visualization of this function. If the block level is set to zero (0), blocking is not in use.

Figure. 4.4.12 - 75. Example of the block setting operation.

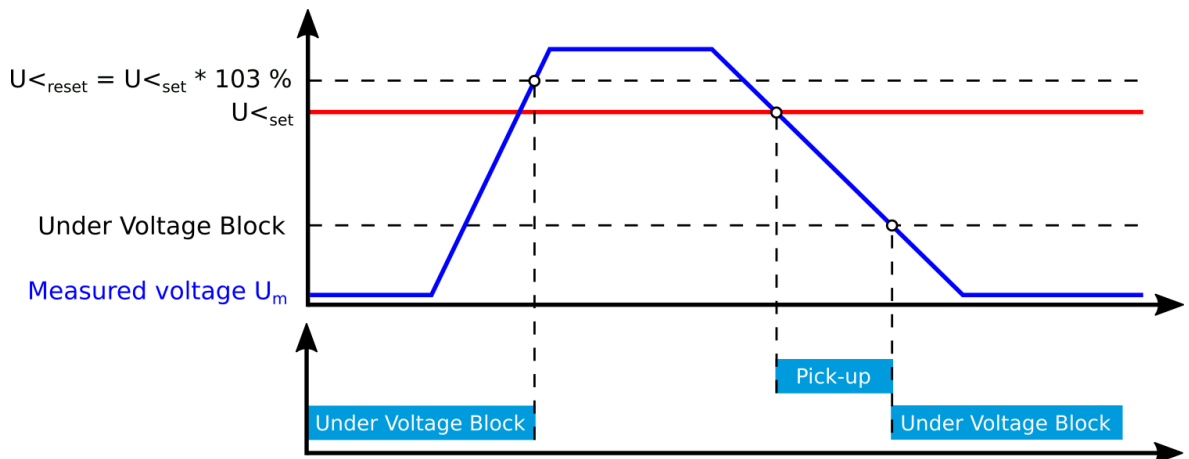

### Read-only parameters

The function's *Info* page displays useful, real-time information on the state of the protection function. It is accessed either through the device's HMI display, or through the setting tool software when it is connected to the device and its Live Edit mode is active.

Table. 4.4.12 - 133. Information displayed by the function.

| Name                  | Range  | Step | Description   |
|-----------------------|--|------|---|
| U1/2 >/< LN behaviour | <ul style="list-style-type: none"> <li>On</li> <li>Blocked</li> <li>Test</li> <li>Test/Blocked</li> <li>Off</li> </ul> | -    | Displays the mode of VUB block. This parameter is visible only when <i>Allow setting of individual LN mode</i> is enabled in <i>General</i> menu. |

| Name                                | Range                        | Step               | Description   |
|-------------------------------------|------------------------------|--------------------|---|
| U1/2 >/<<br>Pick-up setting         | 0.0...1 000 000.0V           | 0.1V               | The primary voltage required for tripping. The displayed pick-up voltage level depends on the pick-up setting and the voltage transformer settings.   |
| Expected operating time             | 0.000...1800.000s            | 0.005s             | Displays the expected operating time when a fault occurs. When IDMT mode is used, the expected operating time depends on the measured voltage value. If the measured voltage changes during a fault, the expected operating time changes accordingly. |
| Time remaining to trip              | -1800.000...1800.000s        | 0.005s             | When the function has detected a fault and counts down time towards a trip, this displays how much time is left before tripping occurs.   |
| $U_{meas}/U_{set}$<br>at the moment | 0.00...1250.00 $U_m/U_{set}$ | 0.01 $U_m/U_{set}$ | The ratio between the measured voltage and the pick-up value.   |

### Function blocking

The blocking signal is evaluated at the start of each program cycle. The blocking signals are connected to the function's dedicated input, which can be configured in the *IO* → *Blocking Input Control* tab of the function.

- When the pick-up element activates and the blocking signal is not active, a START signal is generated, and the function starts or continues with the trip time countdown.
- When the pick-up element activates and the blocking signal is active, a BLOCKED signal is generated, and the function does not process the event further.
- When a START signal is already active and the blocking input signal becomes active, the START signal is reset and BLOCKED signal is generated. The release time characteristics are then processed in the same way as when the pick-up signal is reset.

The blocking signal needs to reach the device minimum of 5 ms before the set operating delay has passed in order for the blocking to activate in time.

### Operating time characteristics for trip and reset

The operating timers' behavior during a function can be set for TRIP signal and also for the release of the function in case the pick-up element is reset before the trip time has been reached. There are three basic operating modes available for the function:

- Instant operation: gives the TRIP signal with no additional time delay simultaneously with the START signal.
- Definite time operation (DT): gives the TRIP signal after a user-defined time delay regardless of the measured or calculated voltage as long as the voltage is above the  $U_{set}$  value and thus the pick-up element is active (independent time characteristics).
- Inverse definite minimum time (IDMT): gives the TRIP signal after a time which is in relation to the set pick-up voltage  $U_{set}$  and the measured voltage  $U_m$  (dependent time characteristics).

The IDMT function follows one of the following formulas:

$$\begin{array}{cc}
 \text{Overvoltage} & \text{Undervoltage} \\
 t = \frac{k}{\left(\frac{U_m}{U_s}\right)^a - 1} & t = \frac{k}{1 - \left(\frac{U_m}{U_s}\right)^a}
 \end{array}$$

Where:

- $t$  = operating time
- $k$  = time dial setting
- $U_m$  = measured voltage
- $U_s$  = pick-up setting
- $a$  = IDMT multiplier setting

The following table presents the setting parameters for the function's time characteristics.

Table. 4.4.12 - 134. Setting parameters for operating time characteristics.

| Name                          | Range  | Step   | Default | Description   |
|-------------------------------|--|--------|---------|---|
| Delay type                    | <ul style="list-style-type: none"> <li>• DT</li> <li>• IDMT</li> </ul> | -      | DT      | Selection of the delay type time counter. The selection possibilities are dependent (IDMT, Inverse Definite Minimum Time) and independent (DT, Definite Time) characteristics.  |
| Definite operating time delay | 0.000...1800.000s  | 0.005s | 0.040s  | Definite time operating delay. The setting is active and visible when DT is the selected delay type.<br>When set to 0.000 s, the stage operates as instant without added delay. When the parameter is set to 0.005...1800 s, the stage operates as independent delayed. |
| Time dial setting k           | 0.01...60.00s  | 0.01s  | 0.05s   | The setting is active and visible when IDMT is the selected delay type.<br>Time dial/multiplier setting for IDMT characteristics.   |
| IDMT Multiplier               | 0.01...25.00s  | 0.01s  | 1.00s   | The setting is active and visible when IDMT is the selected delay type.<br>IDMT time multiplier in the $U_m/U_{set}$ power.   |

Table. 4.4.12 - 135. Setting parameters for reset time characteristics.

| Name  | Range   | Step   | Default | Description   |
|---|---|--------|---------|---|
| Release time delay                            | 0.000...150.000s  | 0.005s | 0.06s   | Resetting time. Time allowed between pick-ups if the pick-up has not led to a trip operation. During this time the START signal is held on for the timers if the delayed pick-up release is active.   |
| Delayed pick-up release                       | <ul style="list-style-type: none"> <li>• No</li> <li>• Yes</li> </ul> | -      | Yes     | Resetting characteristics selection either as time-delayed or as instant after the pick-up element is released. If activated, the START signal is reset after a set release time delay.   |
| Time calc reset after release time            | <ul style="list-style-type: none"> <li>• No</li> <li>• Yes</li> </ul> | -      | Yes     | Operating timer resetting characteristics selection. When active, the operating time counter is reset after a set release time if the pick-up element is not activated during this time. When disabled, the operating time counter is reset directly after the pick-up element reset. |
| Continue time calculation during release time | <ul style="list-style-type: none"> <li>• No</li> <li>• Yes</li> </ul> | -      | No      | Time calculation characteristics selection. If activated, the operating time counter continues until a set release time has passed even if the pick-up element is reset.  |

The user can reset characteristics through the application. The default setting is a 60 ms delay; the time calculation is held during the release time.

In the release delay option the operating time counter calculates the operating time during the release. When using this option the function does not trip if the input signal is not re-activated while the release time count is on-going.

## Events and registers

The sequence voltage function (abbreviated "VUB" in event block names) generates events and registers from the status changes in the events listed below. The user can select which event messages are stored in the main event buffer: ON, OFF, or both. The events triggered by the function are recorded with a time stamp.

The function's outputs can be used for direct I/O controlling and user logic programming. The function also a resettable cumulative counter for the START, TRIP and BLOCKED events.

The function offers four (4) independent stages; the events are segregated for each stage operation.

Table. 4.4.12 - 136. Event messages.

| Event block name | Event names  |
|------------------|--------------|
| VUB1...VUB4      | Start ON/OFF |
| VUB1...VUB4      | Trip ON/OFF  |
| VUB1...VUB4      | Block ON/OFF |

The function registers its operation into the last twelve (12) time-stamped registers; this information is available for all provided instances separately. The register of the function records the ON event process data for START, TRIP or BLOCKED. The table below presents the structure of the function's register content.

Table. 4.4.12 - 137. Register content.

| Register             | Description                |
|----------------------|----------------------------|
| Date and time        | dd.mm.yyyy hh:mm:ss.mss    |
| Event                | Event name                 |
| Pre-trigger voltage  | Start/Trip -20ms voltage   |
| Fault voltage        | Start/Trip voltage         |
| Pre-fault voltage    | Start -200ms voltage       |
| Trip time remaining  | 0 ms...1800s               |
| Setting group in use | Setting group 1...8 active |

### 4.4.13 Overfrequency and underfrequency protection ( $f > / <$ ; 81O/81U)

The frequency protection function can be used both in overfrequency and in underfrequency situations, and it has four (4) stages for both. Frequency protection can be applied to protect feeder, bus, transformer, motor and generator applications. The difference between the generated power and the load demand can cause the frequency to drop below or rise above the allowed level. When the consumption is larger than the generated power, the frequency may drop. When more power is generated than is consumed, overfrequency can occur.

In generator applications too big a load or a malfunction in the power controller can cause the frequency to decrease. Underfrequency causes damage to turbine wings through vibration as well as heating due to increased iron losses, dropped cooling efficiency and over-magnetization in step-up transformers. Overfrequency protection prevents the generator from running too fast which can cause damage to the generator turbine.

Underfrequency and overfrequency protection can be used as an indicator of an accidental island operation in distributed generation and in some consumers (as it is unlikely that the consumed and generated power are the same). Overfrequency is also often used to control power generation to keep the system's frequency consistent.

Each stage can be activated and deactivated individually. After the  $f > / <$  mode has been activated (*Protection → Stage activation → Frequency stages*), the user can activate and deactivate the individual stages at will (*Protection → Frequency → Frequency protection  $f > / <$  → INFO → Stage operational setup*).

Figure. 4.4.13 - 76. Simplified function block diagram of the  $f >$  function.

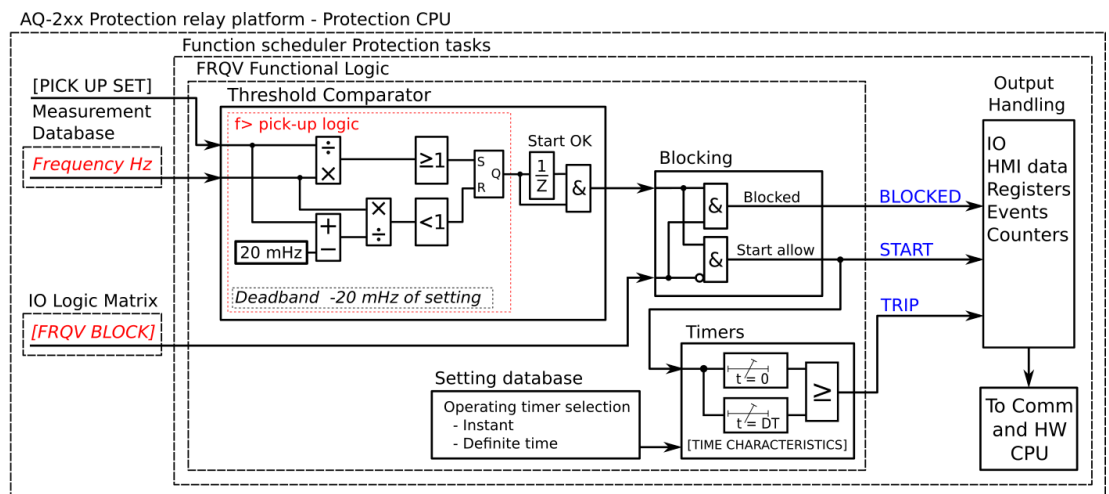
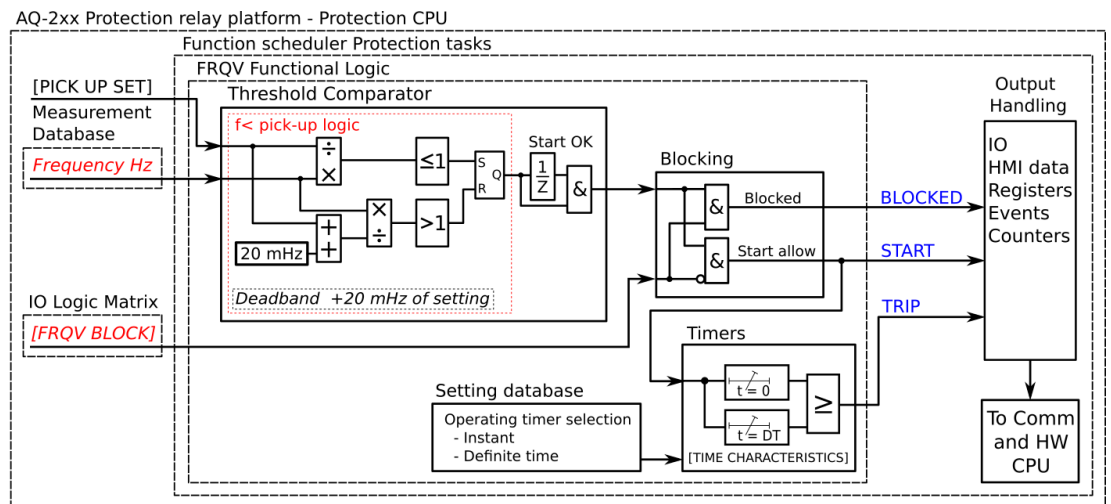

Figure. 4.4.13 - 77. Simplified function block diagram of the f< function.



### Measured input

The frequency protection function compares the measured frequency to the pick-up setting (given in Hz). There are three (3) frequency references available. Please refer to "[Frequency tracking and scaling](#)" chapter for a detailed description of frequency tracking.

Table. 4.4.13 - 138. Measurement inputs of the f>/< function.

| Signals               | Description                   |
|-----------------------|-------------------------------|
| Frequency reference 1 | Primary frequency reference   |
| Frequency reference 2 | Secondary frequency reference |
| Frequency reference 3 | Tertiary frequency reference  |

### General settings

The following general settings define the general behavior of the function. These settings are static i.e. it is not possible to change them by editing the setting group.

Table. 4.4.13 - 139. General settings of the function.

| Name         | Range  | Default | Description   |
|--------------|--|---------|---|
| f</> LN mode | <ul style="list-style-type: none"> <li>On</li> <li>Blocked</li> <li>Test</li> <li>Test/Blocked</li> <li>Off</li> </ul> | On      | Set mode of FRQV block. This parameter is visible only when <i>Allow setting of individual LN mode</i> is enabled in <i>General</i> menu. |

| Name   | Range  | Default | Description  |
|--|--|---------|--|
| f> enable<br>f>> enable<br>f>>> enable<br>f>>>><br>enable<br>f< enable<br>f<< enable<br>f<<< enable<br>f<<<<<br>enable   | <ul style="list-style-type: none"> <li>No</li> <li>Yes</li> </ul>                                      | No      | Enables or disables the stage.   |
| f> force<br>status to<br>f>> force<br>status to<br>f>>> force<br>status to<br>f>>>> force<br>status to<br>f< force<br>status to<br>f<< force<br>status to<br>f<<< force<br>status to<br>f<<<< force<br>status to | <ul style="list-style-type: none"> <li>Normal</li> <li>Start</li> <li>Trip</li> <li>Blocked</li> </ul> | Normal  | Force the status of the function. Visible only when <i>Enable stage forcing</i> parameter is enabled in <i>General</i> menu. |

### Pick-up settings

The  $f_{set>}$ ,  $f_{set>>}$ , etc. setting parameters control the pick-up of each stage of the f>/< function. They define the maximum or minimum allowed measured frequency before action from the function. The function constantly calculates the ratio between the pick-up setting and the measured frequency. The reset ratio of 20mHz is built into the function and is always relative to the pick-up value.

Setting group selection controls the operating characteristics of the function, i.e. the user or user-defined logic can change function parameters while the function is running.

Table. 4.4.13 - 140. Pick-up settings.

| Name                     | Range   | Step    | Default | Description  |
|--------------------------|---|---------|---------|--|
| f> used in setting group | <ul style="list-style-type: none"> <li>No</li> <li>Yes</li> </ul> | -       | No      | Enables or disables the protection stage in the setting group.   |
| fset>                    | 10.00...80.00Hz   | 0.01Hz  | 51Hz    | Pick-up setting  |
| fset<                    | 5.00...75.00Hz  | 0.01Hz  | 49Hz    | Pick-up setting  |
| f< undervoltage block    | 0.00...120.00%Un  | 0.01%Un | 0.00%Un | Block setting. If set to zero, blocking is not in use. When the measured voltage drops below the set value, the operation of the functions is blocked. |

## Operating time characteristics for trip and reset

This function supports definite time delay (DT). For detailed information on these delay types please refer to the chapter "[General properties of a protection function](#)" and its section "[Operating time characteristics](#)".

### Read-only parameters

The function's *Info* page displays useful, real-time information on the state of the protection function. It is accessed either through the device's HMI display, or through the setting tool software when it is connected to the device and its Live Edit mode is active.

Table. 4.4.13 - 141. Information displayed by the function.

| Name                    | Range  | Step                                  | Description   |
|-------------------------|--|---------------------------------------|---|
| f</> LN behaviour       | <ul style="list-style-type: none"> <li>On</li> <li>Blocked</li> <li>Test</li> <li>Test/Blocked</li> <li>Off</li> </ul> | -                                     | Displays the mode of FRQV block.<br>This parameter is visible only when <i>Allow setting of individual LN mode</i> is enabled in <i>General</i> menu. |
| f</> condition          | <ul style="list-style-type: none"> <li>Normal</li> <li>Start</li> <li>Trip</li> <li>Blocked</li> </ul>                 | -                                     | Displays the status of the protection function.   |
| f meas / f set          | 0.000...20.000f <sub>m</sub> /f <sub>set</sub>   | 0.001f <sub>m</sub> /f <sub>set</sub> | The ratio between the measured frequency and the pick-up value.   |
| Expected operating time | 0.000...1800.000s  | 0.005s                                | Displays the expected operating time when a fault occurs.   |
| Time remaining to trip  | -1800.000...1800.000s  | 0.005s                                | When the function has detected a fault and counts down time towards a trip, this displays how much time is left before tripping occurs.               |

### Function blocking

The blocking signal is evaluated at the start of each program cycle. The blocking signals are connected to the function's dedicated input, which can be configured in the *IO → Blocking Input Control* tab of the function.

- When the pick-up element activates and the blocking signal is not active, a START signal is generated, and the function starts or continues with the trip time countdown.
- When the pick-up element activates and the blocking signal is active, a BLOCKED signal is generated, and the function does not process the event further.
- When a START signal is already active and the blocking input signal becomes active, the START signal is reset and BLOCKED signal is generated. The release time characteristics are then processed in the same way as when the pick-up signal is reset.

The blocking signal needs to reach the device minimum of 5 ms before the set operating delay has passed in order for the blocking to activate in time.

## Events and registers

The frequency function (abbreviated "FRQV" in event block names) generates events and registers from the status changes in the events listed below. The user can select which event messages are stored in the main event buffer: ON, OFF, or both. The events triggered by the function are recorded with a time stamp.

The function's outputs can be used for direct I/O controlling and user logic programming. The function also provides a resettable cumulative counter for the START, TRIP and BLOCKED events.

Table. 4.4.13 - 142. Event messages.

| Event block name | Event names         |
|------------------|---------------------|
| FRQV1            | f>/< Start ON/OFF   |
| FRQV1            | f>/< Trip ON/OFF    |
| FRQV1            | f>/< Blocked ON/OFF |

The function registers its operation into the last twelve (12) time-stamped registers. The table below presents the structure of the function's register content.

Table. 4.4.13 - 143. Register content.

| Register             | Description                |
|----------------------|----------------------------|
| Date and time        | dd.mm.yyyy hh:mm:ss.mss    |
| Event                | Event name                 |
| f Pre-trig (Hz)      | Start/Trip -20ms frequency |
| f Fault (Hz)         | Fault frequency            |
| Setting group in use | Setting group 1...8 active |

### 4.4.14 Rate-of-change of frequency (df/dt>/<; 81R)

The rate-of-change of frequency function is used to detect fast drops or increases in frequency. If the load changes fast this function detects and clears the frequency-based faults faster than conventional underfrequency and overfrequency protections. One of the most common causes for the frequency to deviate from its nominal value is an unbalance between the generated power and the load demand. If the unbalance is big the frequency changes rapidly.

The rate-of-change of frequency protection can also be applied to detect a loss of mains situation. Loss of mains is a situation where a part of the network (incorporating generation) loses its connection with the rest of the system (i.e. becomes an islanded network). A generator that is not disconnected from the network can cause safety hazards. A generator can also be automatically reconnected to the network, which can cause damage to the generator and the network.

Figure. 4.4.14 - 78. Operation of the  $df/dt >/<$  function when the frequency starts but doesn't trip.

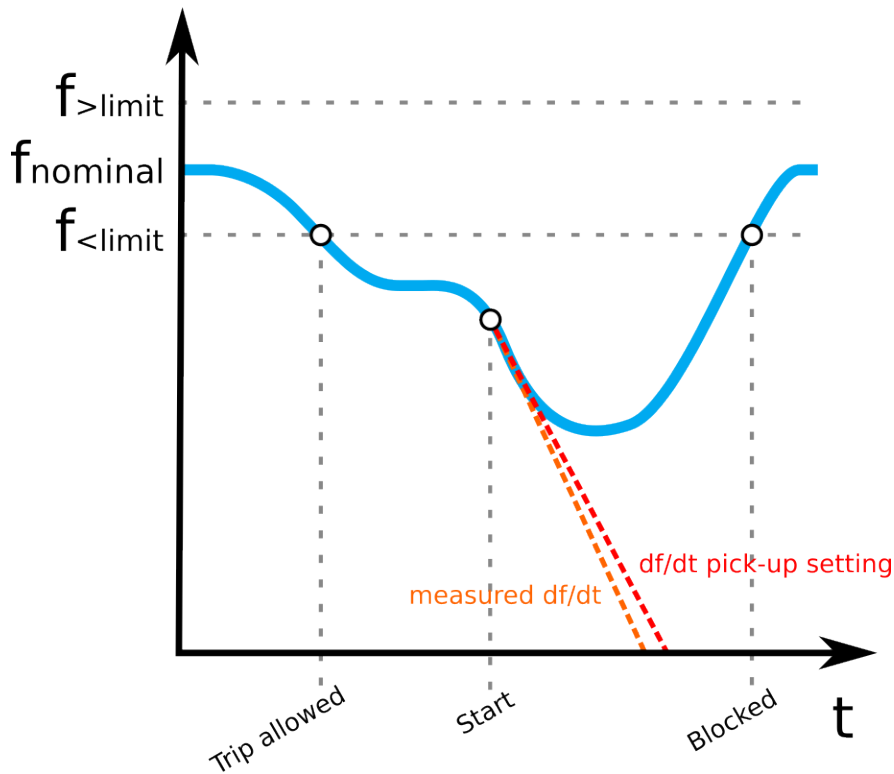

The figure above presents an example of the  $df/dt >/<$  function's operation when the frequency is decreasing. If the  $f_{<limit}$  and/or  $f_{>limit}$  is activated, the function does not trip no matter how fast the measured frequency changes if it's over the  $f_{<limit}$  or under  $f_{>limit}$ . As can be seen in the figure above, when the frequency decreases under the  $f_{<limit}$ , tripping is allowed although the change of frequency is not yet fast enough for the function to trip. Later the frequency makes a fast dip and as a result the change of frequency is faster than the set pick-up value which then causes the function to operate.

Each stage can be activated and deactivated individually. After the  $f >/<$  mode has been activated (*Protection → Stage activation → Frequency stages*), the user can activate and deactivate the individual stages at will (*Protection → Frequency → Frequency protection  $f >/<$  → INFO → Stage operational setup*).

Figure. 4.4.14 - 79. Simplified function block diagram of the  $df/dt >/<$  function.

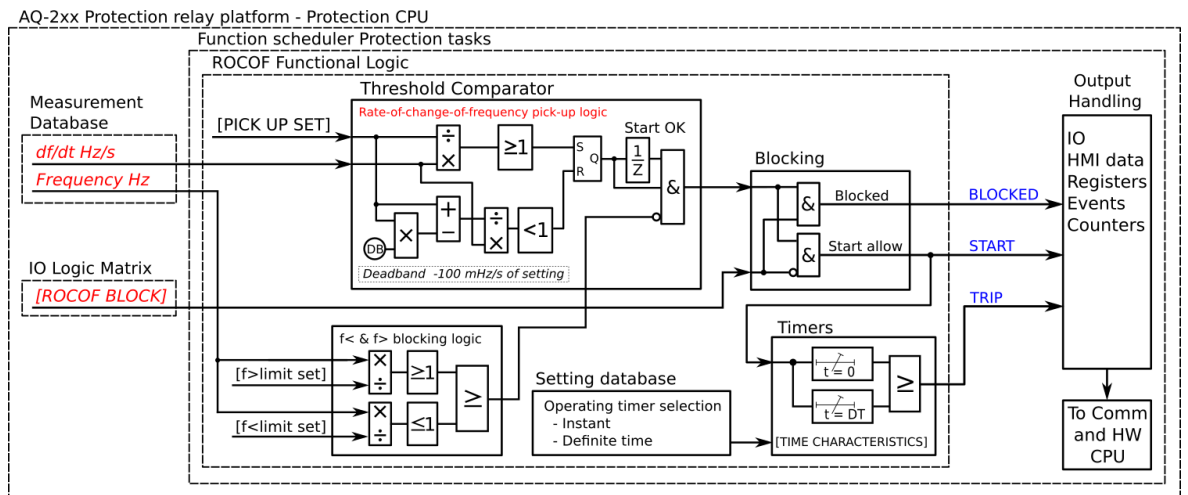

## Measured input

The rate-of-change of frequency protection function compares the measured  $df/dt$  ratio to the pick-up setting (given in Hz/s). There are three (3) frequency references available. Please refer to "[Frequency tracking and scaling](#)" chapter for a detailed description of frequency tracking.

Table. 4.4.14 - 144. Measurement inputs of the  $df/dt$  function.

| Signals               | Description                   |
|-----------------------|-------------------------------|
| Frequency reference 1 | Primary frequency reference   |
| Frequency reference 2 | Secondary frequency reference |
| Frequency reference 3 | Tertiary frequency reference  |

## General settings

The following general settings define the general behavior of the function. These settings are static i.e. it is not possible to change them by editing the setting group.

Table. 4.4.14 - 145. General settings of the function.

| Name                                | Range  | Step      | Default | Description  |
|-------------------------------------|--|-----------|---------|--|
| $df/dt$ >/< LN mode                 | <ul style="list-style-type: none"> <li>On</li> <li>Blocked</li> <li>Test</li> <li>Test/Blocked</li> <li>Off</li> </ul> | -         | On      | Set mode of DFT block. This parameter is visible only when <i>Allow setting of individual LN mode</i> is enabled in <i>General</i> menu. |
| Max allowed $df/dt$ rate            | 0.10...50.00 Hz/s  | 0.10 Hz/s | 20 Hz/s | If $df/dt$ rate exceeds this setting, the function is blocked.   |
| $df/dt$ >/< (1...8) enable          | <ul style="list-style-type: none"> <li>No</li> <li>Yes</li> </ul>  | -         | No      | Enables or disables the stage.   |
| $df/dt$ >/< (1...8) force status to | <ul style="list-style-type: none"> <li>Normal</li> <li>Start</li> <li>Trip</li> <li>Blocked</li> </ul>                 | -         | Normal  | Force the status of the function. Visible only when <i>Enable stage forcing</i> parameter is enabled in <i>General</i> menu.             |

## Pick-up and time delay

The  $df/dt$  >/< (1) pick-up,  $df/dt$  >/< (2) pick-up, etc. setting parameters control the pick-up of each stage of the  $df/dt$  >/< function. They define the maximum or minimum allowed change of frequency before action from the function. The function constantly calculates the ratio between the pick-up setting and the measured  $df/dt$  >/<. The reset ratio of +/- 100 mHz/s is built into the function and is always relative to the pick-up value. The  $f$  >/< limit value is used to block the function from operating near the nominal frequency.

Setting group selection controls the operating characteristics of the function, i.e. the user or user-defined logic can change function parameters while the function is running.

Table. 4.4.14 - 146. Pick-up settings.

| Name   | Range   | Step     | Default  | Description   |
|--|---|----------|----------|---|
| df/dt>/<<br>(1...8)<br>used in<br>setting<br>group | <ul style="list-style-type: none"> <li>No</li> <li>Yes</li> </ul>                       | -        | No       | Enables the protection stage in setting group.  |
| df/dt>/<<br>(1...8)<br>operating<br>mode           | <ul style="list-style-type: none"> <li>Rising</li> <li>Falling</li> <li>Both</li> </ul> | -        | Rising   | Defines the operation mode of the protection stage. In "Rising" mode df/dt function can trip only from increasing frequency. In "Falling" mode df/dt function can trip only from decreasing frequency. "Both" allows df/dt to trip from both. |
| df/dt>/<<br>(1...8)<br>frequency<br>limit          | <ul style="list-style-type: none"> <li>Not used</li> <li>Use f limit</li> </ul>         | -        | Not used | Displays if frequency limits are used or not.   |
| df/dt>/<<br>(1...8)<br>pick-up                     | 0.01...10.00Hz/s  | 0.01Hz/s | 0.2Hz/s  | Pick-up setting.  |
| df/dt>/<<br>(1...8) f<<br>limit                    | 7.00...65.00Hz  | 0.01Hz   | 49.95Hz  | Underfrequency limit. Tripping is permitted when measured frequency is under this value. This parameter is visible only when operation mode is set to "Falling" or "Both".  |
| df/dt>/<<br>(1...8) f><br>limit                    | 10.00...70.00Hz   | 0.01Hz   | 51Hz     | Overfrequency limit. Tripping is permitted if measured frequency is above this value. This parameter is visible only when operation mode is set to "Rising" or "Both".  |

### Operating time characteristics for trip and reset

This function supports definite time delay (DT). For detailed information on these delay types please refer to the chapter "[General properties of a protection function](#)" and its section "[Operating time characteristics](#)".

### Read-only parameters

The function's *Info* page displays useful, real-time information on the state of the protection function. It is accessed either through the device's HMI display, or through the setting tool software when it is connected to the device and its Live Edit mode is active.

Table. 4.4.14 - 147. Information displayed by the function.

| Name                      | Range  | Step      | Description  |
|---------------------------|--|-----------|--|
| df/dt >/< LN<br>behaviour | <ul style="list-style-type: none"> <li>On</li> <li>Blocked</li> <li>Test</li> <li>Test/Blocked</li> <li>Off</li> </ul> | -         | Displays the mode of DFT block.<br>This parameter is visible only when <i>Allow setting of individual LN mode</i> is enabled in <i>General</i> menu. |
| Measured df/<br>dt        | 0.000...20.000Hz/s   | 0.001Hz/s | Rate-of-change-of-frequency at the moment.   |

| Name                                     | Range  | Step      | Description   |
|--|--|-----------|---|
| df/dt >/< (1...8) condition              | <ul style="list-style-type: none"> <li>• Normal</li> <li>• Start</li> <li>• Trip</li> <li>• Blocked</li> </ul> | -         | Displays the status of the protection function.   |
| df/dt >/< (1...8) df/dt meas / df/dt set | 0.000...20.000p.u.   | 0.005p.u. | The ratio between the rate-of-change-of-frequency and the pick-up value.  |
| Expected operating time                  | 0.000...1800.000s  | 0.005s    | Displays the expected operating time when a fault occurs.   |
| Time remaining to trip                   | -1800.000...1800.000s  | 0.005s    | When the function has detected a fault and counts down time towards a trip, this displays how much time is left before tripping occurs. |

## Function blocking

The blocking signal is evaluated at the start of each program cycle. The blocking signals are connected to the function's dedicated input, which can be configured in the *IO → Blocking Input Control* tab of the function.

- When the pick-up element activates and the blocking signal is not active, a START signal is generated, and the function starts or continues with the trip time countdown.
- When the pick-up element activates and the blocking signal is active, a BLOCKED signal is generated, and the function does not process the event further.
- When a START signal is already active and the blocking input signal becomes active, the START signal is reset and BLOCKED signal is generated. The release time characteristics are then processed in the same way as when the pick-up signal is reset.

The blocking signal needs to reach the device minimum of 5 ms before the set operating delay has passed in order for the blocking to activate in time.

## Events and registers

The rate-of-change of frequency function (abbreviated "DFT" in event block names) generates events and registers from the status changes in the events listed below. The user can select which event messages are stored in the main event buffer: ON, OFF, or both. The events triggered by the function are recorded with a time stamp.

The function's outputs are can be used for direct I/O controlling and user logic programming. The function also provides a resettable cumulative counter for the START, TRIP and BLOCKED events.

Table. 4.4.14 - 148. Event messages.

| Event block name | Event names                     |
|------------------|---------------------------------|
| DFT1             | df/dt>/< (1...8) Start ON/OFF   |
| DFT1             | df/dt>/< (1...8) Trip ON/OFF    |
| DFT1             | df/dt>/< (1...8) Blocked ON/OFF |

The function registers its operation into the last twelve (12) time-stamped registers. The table below presents the structure of the function's register content.

Table. 4.4.14 - 149. Register content.

| Register                 | Description                |
|--------------------------|----------------------------|
| Date and time            | dd.mm.yyyy hh:mm:ss.mss    |
| Event                    | Event name                 |
| df/dt>/< Pre-trig (Hz/s) | Start/Trip –20ms df/dt>/<  |
| f Pre-trig (Hz)          | Start/Trip –20ms frequency |
| df/dt>/< Fault (Hz/s)    | Fault df/dt>/<             |
| f Fault (Hz)             | Fault frequency            |
| Setting group in use     | Setting group 1...8 active |

### 4.4.15 Power protection (P, Q, S>/<; 32)

The power protection function is for instant and time-delayed, three-phase overpower or underpower protection (active, reactive, or apparent). The user can select the operating mode with parameter settings.

Figure. 4.4.15 - 80. PQ diagram of the pick-up areas in various modes.

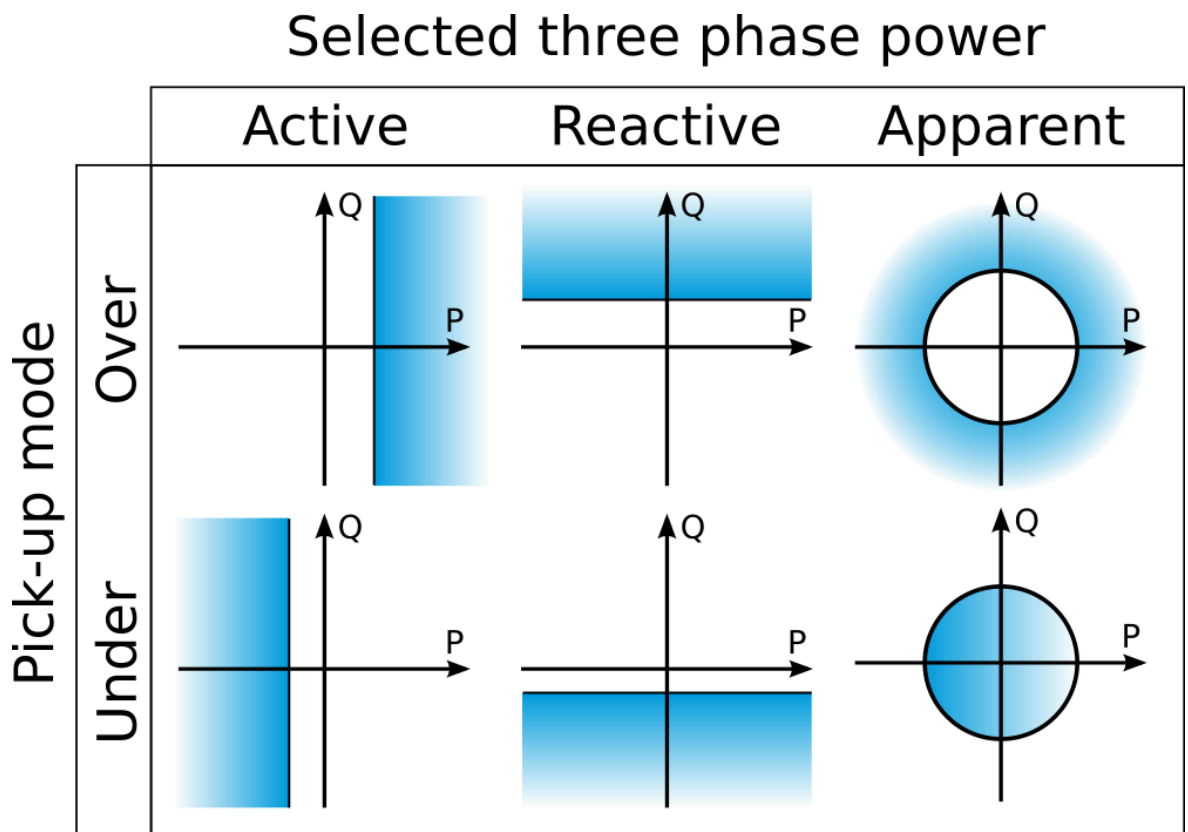
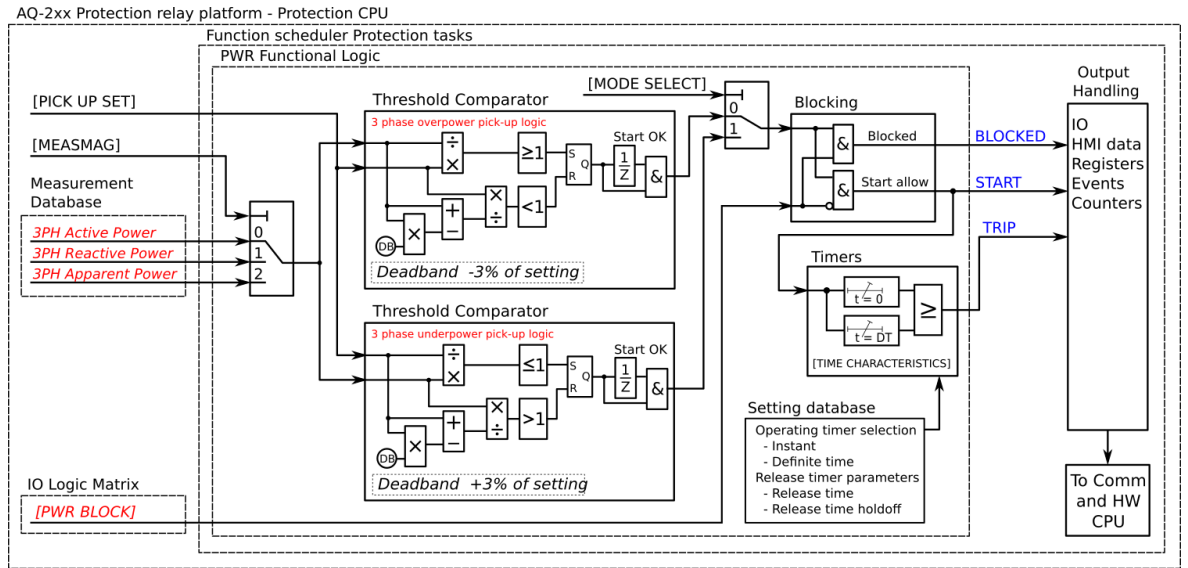

Figure. 4.4.15 - 81. Simplified function block diagram of the power protection function.



### Measured input

The function block uses three phase currents and line-to-neutral or line-to-line voltages to calculate active, reactive or apparent power (as the user chooses). Please refer to "[Power and energy calculation](#)" chapter for a detailed description of power calculation.

Table. 4.4.15 - 150. Measurement inputs of the P> function.

| Signal              | Description  |
|---------------------|--|
| I <sub>L1</sub> RMS | Fundamental frequency component of phase L1 (A) current measurement      |
| I <sub>L2</sub> RMS | Fundamental frequency component of phase L2 (B) current measurement      |
| I <sub>L3</sub> RMS | Fundamental frequency component of phase L3 (C) current measurement      |
| U <sub>1</sub> RMS  | Fundamental frequency component of U <sub>1</sub> /V voltage measurement |
| U <sub>2</sub> RMS  | Fundamental frequency component of U <sub>2</sub> /V voltage measurement |
| U <sub>3</sub> RMS  | Fundamental frequency component of U <sub>3</sub> /V voltage measurement |
| U <sub>4</sub> RMS  | Fundamental frequency component of U <sub>4</sub> /V voltage measurement |

### General settings

The following general settings define the general behavior of the function. These settings are static i.e. it is not possible to change them by editing the setting group.

Table. 4.4.15 - 151. General settings of the function.

| Name                    | Range  | Default | Description  |
|-------------------------|--|---------|--|
| PQS>/< LN mode          | <ul style="list-style-type: none"> <li>On</li> <li>Blocked</li> <li>Test</li> <li>Test/Blocked</li> <li>Off</li> </ul> | On      | Set mode of PWR block. This parameter is visible only when <i>Allow setting of individual LN mode</i> is enabled in <i>General</i> menu.     |
| PQS>/< force status to  | <ul style="list-style-type: none"> <li>Normal</li> <li>Start</li> <li>Trip</li> <li>Blocked</li> </ul>                 | Normal  | Force the status of the function. Visible only when <i>Enable stage forcing</i> parameter is enabled in <i>General</i> menu.                 |
| PQS>/< measurement side | <ul style="list-style-type: none"> <li>POW1</li> <li>POW2</li> </ul>   | POW1    | Defines which side of power measurement is used. POW1 and POW2 can be set up at <i>Measurements</i> → <i>Power and energy measurements</i> . |

### Pick-up settings

The PQS>/< setting parameter controls the pick-up of the power protection function. This defines the maximum or minimum allowed measured three-phase power (active, reactive, or apparent) before action from the function. The function constantly calculates the ratio between the PQS>/< and the measured power magnitude. The reset ratios of 97 % (pick-up mode "Over") and 103 % (pick-up mode "Under") are built into the function and is always relative to the pick-up value.

Setting group selection controls the operating characteristics of the function, i.e. the user or user-defined logic can change function parameters while the function is running.

Table. 4.4.15 - 152. Pick-up settings.

| Name                  | Range  | Step      | Default      | Description   |
|-----------------------|--|-----------|--------------|---|
| Measured magnitude    | <ul style="list-style-type: none"> <li>P3PH</li> <li>Q3PH</li> <li>S3PH</li> </ul>                                 | -         | P3PH         | Defines which three phase power is used: Active, reactive or apparent power.  |
| Nominal MVA reference | <ul style="list-style-type: none"> <li>Set manually</li> <li>Use Gen nom MVA</li> <li>Use Trafo nom MVA</li> </ul> | -         | Set manually | Defines whether the used nominal power is set manually or if transformer or generator status monitoring function defines the nominal power automatically. |
| Set nominal MVA       | 0.0001...1000.0000MVA  | 0.0001MVA | 10MVA        | Nominal MVA used by the function. This parameter is visible only when "Nominal MVA reference" parameter is set to "Set manually"                          |
| Pick-up mode          | <ul style="list-style-type: none"> <li>&gt; Over</li> <li>&lt; Under</li> </ul>                                    | -         | Over         | Defines whether the function operates in underpower or overpower protection mode.   |
| Pick-up               | -500.000...500.000%  | 0.005%    | 0%           | Pick-up setting. Related to the nominal power set by the user.  |

## Read-only parameters

The function's *Info* page displays useful, real-time information on the state of the protection function. It is accessed either through the device's HMI display, or through the setting tool software when it is connected to the device and its Live Edit mode is active.

Table. 4.4.15 - 153. Information displayed by the function.

| Name                        | Range   | Step     | Description   |
|-----------------------------|---|----------|---|
| PQS>/< LN behaviour         | On<br>Blocked<br>Test<br>Test/Blocked<br>Off          | -        | Displays the mode of PWR block.<br>This parameter is visible only when <i>Allow setting of individual LN mode</i> is enabled in <i>General</i> menu.                        |
| PQS>/< condition            | Normal<br>Start<br>Trip<br>Blocked                    | -        | Displays the status of the protection function.   |
| PQS>/< selected measurement | POW1CT1<br>POW1CT2<br>POW2CT1<br>POW2CT2<br>Undefined | -        | Displays the selected power measurement.<br>This indication is visible if the device has more than one current measurement unit.  |
| Nominal MVA used            | 0.000...1800.000MVA                                   | 0.001MVA | Displays the nominal power used by the function. This parameter is displayed if "Nominal MVA reference" parameter has been set to "Use Gen nom MVA" or "Use Trafo nom MVA". |
| Pick-up setting             | -1800.000...1800.000MVA                               | 0.001MVA | Pick-up setting used at the moment by the function. Value of this parameter can change if setting group has been changed.   |
| Measurement now             | -1800.000...1800.000MVA                               | 0.001MVA | Measured active, reactive or apparent power at the moment.  |
| Meas/Set at the moment      | -1250.00...1250.00p.u.                                | 0.01p.u. | Ratio between the measured power and pick-up setting.   |
| Meas/Nom at the moment      | -1250.00...1250.00p.u.                                | 0.01p.u. | Ratio between the measured power and used nominal power value.  |
| Expected operating time     | 0.000...1800.000s                                     | 0.005s   | Displays the expected operating time when a fault occurs.   |
| Time remaining to trip      | -1800.000...1800.000s                                 | 0.005s   | When the function has detected a fault and counts down time towards a trip, this displays how much time is left before tripping occurs.                                     |

## Function blocking

The blocking signal is evaluated at the start of each program cycle. The blocking signals are connected to the function's dedicated input, which can be configured in the *IO* → *Blocking Input Control* tab of the function.

- When the pick-up element activates and the blocking signal is not active, a START signal is generated, and the function starts or continues with the trip time countdown.

- When the pick-up element activates and the blocking signal is active, a BLOCKED signal is generated, and the function does not process the event further.
- When a START signal is already active and the blocking input signal becomes active, the START signal is reset and BLOCKED signal is generated. The release time characteristics are then processed in the same way as when the pick-up signal is reset.

The blocking signal needs to reach the device minimum of 5 ms before the set operating delay has passed in order for the blocking to activate in time.

### Operating time characteristics for trip and reset

This function supports definite time delay (DT). For detailed information on these delay types please refer to the chapter "[General properties of a protection function](#)" and its section "[Operating time characteristics](#)".

### Events and registers

The power protection function (abbreviated "PWR" in event block names) generates events and registers from the status changes in the events listed below. The user can select which event messages are stored in the main event buffer: ON, OFF, or both. The events triggered by the function are recorded with a time stamp.

The function's output can be used for direct I/O controlling and user logic programming. The function also a resettable cumulative counter for the START, TRIP and BLOCKED events.

The function offers four (4) independent stages; the events are segregated for each stage operation.

Table. 4.4.15 - 154. Event messages.

| Event block name | Event names  |
|------------------|--------------|
| PWR1...PWR4      | Start ON/OFF |
| PWR1...PWR4      | Trip ON/OFF  |
| PWR1...PWR4      | Block ON/OFF |

The function registers its operation into the last twelve (12) time-stamped registers. The register of the function records the ON event process data for START, TRIP or BLOCKED. The table below presents the structure of the function's register content.

Table. 4.4.15 - 155. Register content.

| Register             | Description                |
|----------------------|----------------------------|
| Date and time        | dd.mm.yyyy hh:mm:ss.mss    |
| Event                | Event name                 |
| Pre-trigger power    | Start/Trip -20ms power     |
| Fault power          | Start/Trip power           |
| Pre-fault power      | Start -200ms power         |
| Trip time remaining  | 0 ms...1800s               |
| Setting group in use | Setting group 1...8 active |

### 4.4.16 Transformer status monitoring

The transformer status monitoring function is designed to be the one place where the user can set up all necessary transformer data and select the used transformer protection functions. Settings related to the protection functions can also be edited inside each function and any changes are updated into this function as well. The function calculates many transformer-related properties which are used in functions that protect and monitor the transformer. Standard transformers require only name plate data and CT scalings to get the protection device to automatically scale all measurement signals to the transformer. In special transformers manually set values can be applied to cover the transformer properties that are rarely met. Additionally, the function counts a transformer's cumulative overloading and high overcurrent time.

These signals can be used in indication or in logic programming, and they are the basis for the events the function generates (if so chosen).

Figure. 4.4.16 - 82. Simplified function block diagram of the transformer status monitoring function.

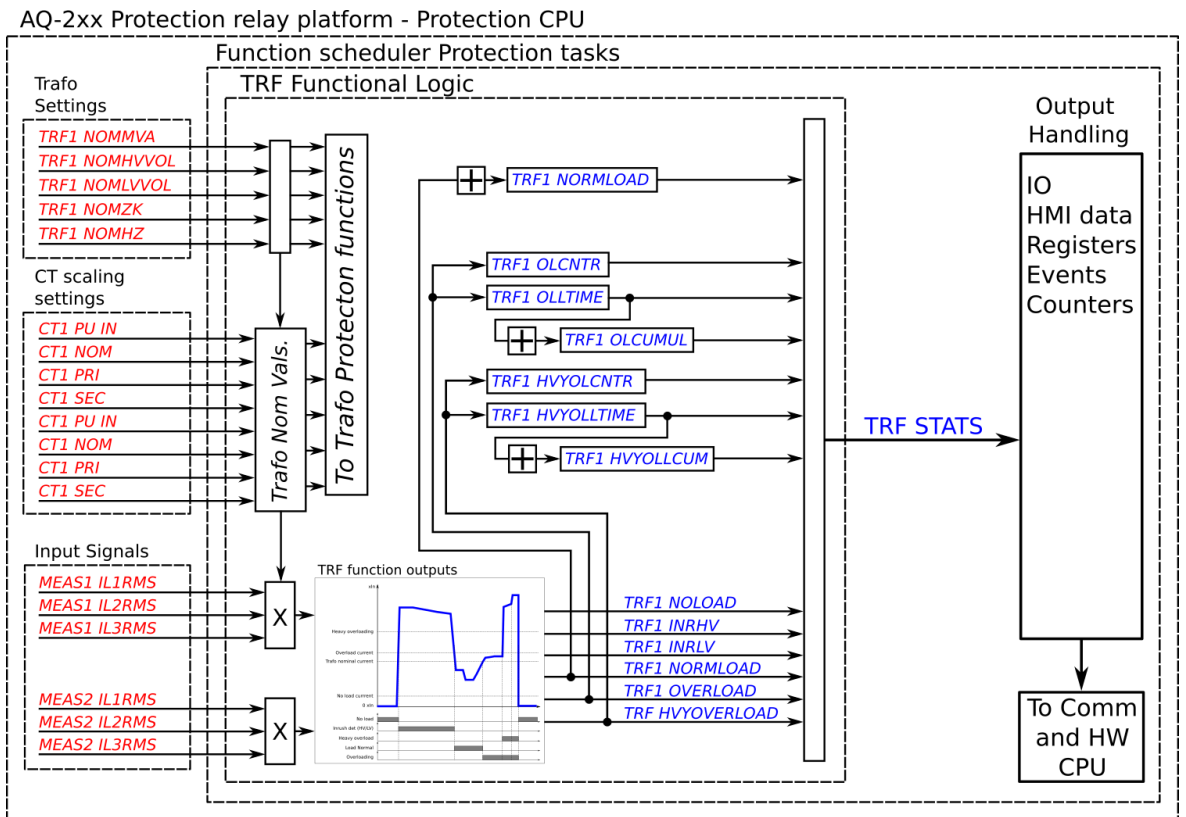

The function's outputs are dependent on the set transformer data because the measured currents (in p.u.) are related to the transformer nominal values. The following diagram presents the function's outputs in various situations.

Figure. 4.4.16 - 83. Activation of the function's outputs.

TRF function outputs

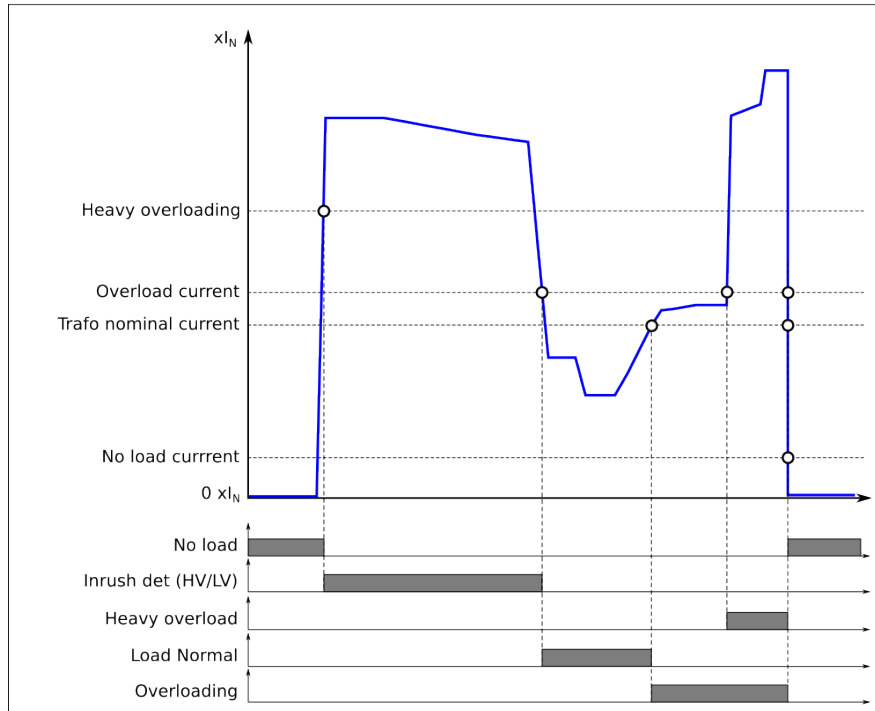

The **No load** signal is activated when the current dips below the "No load current" limit ( $= 0.2 \times I_n$ ) for longer than ten milliseconds. If the current increases from this situation up to the "Heavy overloading" limit ( $> 1.3 \times I_n$ ), the **HV inrush detection** and **LV inrush detection** signals are activated. If the measured current is between the "No load current" limit and the "Nominal current" limit, the **Load normal** signal is activated. If the measured current is between the "Nominal" and the "Heavy overloading" currents, the **Overloading** signal is activated.

These signals can be used for multiple purposes: information, transformer-related logics, and monitoring. A constant, long-lasting heavy overloading can cause oil ageing in the transformer, and thus more frequent maintenance is recommended to prevent possible problems in the transformer.

Settings and signals

The settings of the transformer status monitoring function are mostly shared with other transformer protection functions in the transformer module of the device. The following table shows these other functions that also use these settings.

Table. 4.4.16 - 156. Settings of the transformer status monitoring function and how they are shared by other protection functions.

| Name        | Range  | Step | Default | Description   |
|-------------|--|------|---------|---|
| TRF LN mode | <ul style="list-style-type: none"> <li>• On</li> <li>• Blocked</li> <li>• Test</li> <li>• Test/Blocked</li> <li>• Off</li> </ul> | -    | On      | Set mode of MST block.<br>This parameter is visible only when <i>Allow setting of individual LN mode</i> is enabled in <i>General</i> menu. |

| Name                                    | Range  | Step   | Default | Description  |
|---|--|--------|---------|--|
| TRF LN behaviour                        | <ul style="list-style-type: none"> <li>• On</li> <li>• Blocked</li> <li>• Test</li> <li>• Test/Blocked</li> <li>• Off</li> </ul>   | -      | -       | Displays the mode of MST block.<br>This parameter is visible only when <i>Allow setting of individual LN mode</i> is enabled in <i>General</i> menu.   |
| Transformer parameters controlled by SG | <ul style="list-style-type: none"> <li>• No</li> <li>• Yes</li> </ul>  | -      | No      | If this parameter is set to "Yes" it is possible to change transformer nameplate values instantly by switching between up to eight (8) setting groups. See "Transformer setting groups" section below. |
| TRF force status to                     | <ul style="list-style-type: none"> <li>• NoForce</li> <li>• Light/NoLoad</li> <li>• HV inrush</li> <li>• LV inrush</li> <li>• Normload</li> <li>• Overload</li> <li>• High Overload</li> </ul> | -      | NoForce | Force the status of the function. Visible only when <i>Enable stage forcing</i> parameter is enabled in <i>General</i> menu.   |
| Transformer nominal                     | 0.1...500.0MVA   | 0.1MVA | 1.0MVA  | The nominal MVA of the transformer. This value is used to calculate the nominal currents onf both the HV and the LV side.  |
| HV side nominal voltage                 | 0.1...500.0kV  | 0.1kV  | 110.0kV | The HV side nominal voltage of the transformer. This value is used to calculate the nominal currents of the HV side.   |
| LV side nominal voltage                 | 0.1...500.0kV  | 0.1kV  | 110.0kV | The LV side nominal voltage of the transformer. This value is used to calculate the nominal currents of the LV side.   |
| Transformer Zk%                         | 0.01...25.00%  | 0.01%  | 3.00%   | The transformer's short-circuit impedance in percentages. Used for calculating short-circuit current.  |
| Transformer nom. freq.                  | 10...75Hz  | 1Hz    | 50Hz    | The transformer's nominal frequency. Used for calculating the transformer's nominal short-circuit inductance.  |

| Name                           | Range  | Step   | Default     | Description  |
|--------------------------------|--|--------|-------------|--|
| Transf. vect. group            | <ul style="list-style-type: none"> <li>• Manual set</li> <li>• Yy0</li> <li>• Yyn0</li> <li>• YNy0</li> <li>• YNyn0</li> <li>• Yy6</li> <li>• Yyn6</li> <li>• YNy6</li> <li>• YNyn6</li> <li>• Yd1</li> <li>• YNd1</li> <li>• Yd7</li> <li>• YNd7</li> <li>• Yd11</li> <li>• YNd11</li> <li>• Yd5</li> <li>• YNd5</li> <li>• Dy1</li> <li>• Dyn1</li> <li>• Dy7</li> <li>• Dyn7</li> <li>• Dy11</li> <li>• Dyn11</li> <li>• Dy5</li> <li>• Dyn5</li> <li>• Dd0</li> <li>• Dd6</li> </ul> | -      | Yy0         | <p>The selection of the transformer's vector group. The selection values (1–26) are predefined so that the scaling and vector matching are applied in the protection device automatically when the correct vector group is selected. The predefinitions assume that the HV side is connected to the CT1 module and that the LV side is connected to the CT2 module.</p> <p>If the protected transformer vector group is not found in the predefined list, it can be manually set by selecting the option "Manual set".</p> |
| HV side Star or Zigzag / Delta | <ul style="list-style-type: none"> <li>• Star/Zigzag</li> <li>• Delta</li> </ul>   | -      | Star/Zigzag | The selection of the HV side connection. Can be selected between star or zigzag and delta. This selection is visible only if the option "Manual set" is selected for the vector group setting.   |
| HV side earthed                | <ul style="list-style-type: none"> <li>• Not earthed</li> <li>• Earthed</li> </ul>   | -      | Not earthed | The selection of whether or not the zero sequence compensation is applied in the HV side current calculation. The selection is visible only if the option "Manual set" is selected for the vector group setting.   |
| HV side lead or lag LV         | <ul style="list-style-type: none"> <li>• Lead</li> <li>• Lag</li> </ul>  | -      | Lead        | The selection of whether the HV side leads or lags the LV side. The selection is visible only if the option "Manual set" is selected for the vector group setting.   |
| LV side Star or Zigzag / Delta | <ul style="list-style-type: none"> <li>• Star/Zigzag</li> <li>• Delta</li> </ul>   | -      | Star/Zigzag | The selection of the LV side connection. Can be selected between star or zigzag and delta. This selection is visible only if the option "Manual set" is selected for the vector group setting.   |
| LV side earthed                | <ul style="list-style-type: none"> <li>• Not earthed</li> <li>• Earthed</li> </ul>   | -      | Not earthed | The selection of whether or not the zero sequence compensation is applied in the LV side current calculation. The selection is visible only if the option "Manual set" is selected for the vector group setting.   |
| LV side lead or lag HV         | <ul style="list-style-type: none"> <li>• Lead</li> <li>• Lag</li> </ul>  | -      | Lead        | The selection of whether the LV side leads or lags the HV side. The selection is visible only if the option "Manual set" is selected for the vector group setting.   |
| HV-LV side phase angle         | 0.0...360.00deg  | 0.1deg | 0.0deg      | The angle correction factor for HV/LV sides, looked from the HV side. E.g. if the transformer is Dy1, this is set to 30 degrees. The selection is visible only if the option "Manual set" is selected for the vector group setting.  |

| Name                             | Range  | Step               | Default            | Description   |
|----------------------------------|--|--------------------|--------------------|---|
| HV-LV side mag correction        | 0.0...100.0xI <sub>n</sub>   | 0.1xI <sub>n</sub> | 0.0xI <sub>n</sub> | The magnitude correction for the HV-LV side currents (in p.u.), if the currents are not directly matched through the calculations of the nominal values. The selection is visible only if the option "Manual set" for the vector group setting.   |
| Check online HV-LV configuration | <ul style="list-style-type: none"> <li>• -</li> <li>• Check</li> </ul> | -                  | -                  | The selection of whether or not the function checks the current going through the transformer and then compares it to the settings. For this to work, the transformer needs to have a current flowing on both sides and "see" no faults. The selection is visible only if the option "Manual set" is selected for the vector group setting. |

Table. 4.4.16 - 157. Calculations of the transformer status monitoring function.

| Name                            | Range             | Step     | Default  | Description   |
|---------------------------------|-------------------|----------|----------|---|
| HV side nominal current (pri)   | 0.01...50 000.00A | 0.01A    | 0.00A    | The calculated primary current of the transformer's HV side primary current.                              |
| HV side nominal current (sec)   | 0.01...250.00A    | 0.01A    | 0.00A    | The calculated primary current of the transformer's HV side secondary current.                            |
| HV CT nom. to TR nom. factor    | 0.01...250.00p.u. | 0.01p.u. | 0.00p.u. | The transformer's HV side calculated nominal to the CT primary rate.                                      |
| LV side nominal current (pri)   | 0.01...50 000.00A | 0.01A    | 0.00A    | The calculated primary current of the transformer's LV side primary current.                              |
| LV side nominal current (sec)   | 0.01...250.00A    | 0.01A    | 0.00A    | The calculated primary current of the transformer's LV side secondary current.                            |
| LV CT nom. to TR nom. factor    | 0.01...250.00p.u. | 0.01p.u. | 0.00p.u. | The transformer's LV side calculated nominal to the CT primary rate.                                      |
| Transformer nom. impedance      | 0.01...250.00Ω    | 0.01Ω    | 0.00Ω    | The calculated nominal impedance of the transformer.  |
| Transformer nom. Z <sub>k</sub> | 0.01...250.00Ω    | 0.01Ω    | 0.00Ω    | The calculated nominal short-circuit impedance of the transformer.  |
| Transformer nom. SC inductance  | 0.001...250.000μH | 0.01μH   | 0.000μH  | The calculated nominal short-circuit inductance of the transformer.                                       |
| Transformer ratio               | 0.01...250.00     | 0.01     | 0.00     | The transformer's calculated ratio (= HV/LV).   |
| LV side max. 3ph SC curr.       | 0.001...500.000kA | 0.001kA  | 0.000kA  | The calculated maximum three-phase short-circuit current in the LV poles of the transformer.              |
| LV side 3ph SC to HV side       | 0.001...500.000kA | 0.001kA  | 0.000kA  | Shows how the calculated maximum three-phase short-circuit current in the LV side is seen in the HV side. |

| Name                      | Range             | Step    | Default | Description   |
|---------------------------|-------------------|---------|---------|---|
| LV side max. 2ph SC curr. | 0.001...500.000kA | 0.001kA | 0.000kA | The calculated maximum two-phase short-circuit current in the LV poles of the transformer.              |
| LV side 2ph SC to HV side | 0.001...500.000kA | 0.001kA | 0.000kA | Shows how the calculated maximum two-phase short-circuit current in the LV side is seen in the HV side. |

Table. 4.4.16 - 158. Output signals of the transformer status monitoring function.

| Name                                | Description   |
|-------------------------------------|---|
| No/Light load                       | The signal is active, when the function detects a current below the "No load current" limit. This signal presents a situation where there is a very light load, or only one or no side of the transformer is energized. |
| HV side inrush detected             | The signal is active, when the detected current rises above the "High overcurrent" limit in the HV side.  |
| LV side inrush detected             | The signal is active, when the detected current rises above the "High overcurrent" limit in the LV side.  |
| Load normal                         | The signal is active when the measured current is below the "Nominal current" but above the "No load current" limit.  |
| Overloading                         | The signal is active, when the measured current is between the "Nominal current" and the "High overcurrent" limits.   |
| Heavy overloading (HVY overloading) | The signal is active, when the measured current is above the "High overcurrent" limit.  |

## Events

The transformer status monitoring function (abbreviated "TRF" in event block names) generates events from the detected transformer energizing status. The data register is available, based on the events.

Table. 4.4.16 - 159. Event messages.

| Event block name | Event names                                       |
|------------------|---|
| TRF1             | Light/No load ON/OFF                              |
| TRF1             | HV side inrush ON/OFF                             |
| TRF1             | LV side inrush ON/OFF                             |
| TRF1             | Load normal ON/OFF                                |
| TRF1             | Overloading ON/OFF                                |
| TRF1             | High overload ON/OFF                              |
| TRF1             | Setting changes, calculating new transformer data |
| TRF1             | Calculation finished, possible restart            |

The function registers its operation into the last twelve (12) time-stamped registers. The table below presents the structure of the function's register content.

Table. 4.4.16 - 160. Register content.

| Register      | Description                                 |
|---------------|---|
| Date and time | dd.mm.yyyy hh:mm:ss.mss                     |
| Event         | Event name                                  |
| HV L1 current | HV side's Phase L1 current x I <sub>n</sub> |
| HV L2 current | HV side's Phase L2 current x I <sub>n</sub> |
| HV L3 current | HV side's Phase L3 current x I <sub>n</sub> |
| LV L1 current | LV side's Phase L1 current x I <sub>n</sub> |
| LV L2 current | LV side's Phase L2 current x I <sub>n</sub> |
| LV L3 current | LV side's Phase L3 current x I <sub>n</sub> |

## Transformer setting groups

If "Transformer parameters controlled by SG" parameter has been set to "Yes" it is possible to instantly change transformer parameters by changing the active setting group. Transformer parameter setting groups are controlled separately from the general setting group control. This allows for changing the following transformer nameplate values without changing the protection parameters:

- Transformer nominal MVA
- HV side nominal voltage
- LV side nominal voltage
- Transformer vector group
- Transformer Zk %
- Transformer nominal frequency

Setting group selection can be applied to each of the setting groups individually by activating one of the various internal logic inputs or connected digital inputs. The user can also force any of the setting groups on when the "Force SG change" setting is enabled by giving the wanted quantity of setting groups as a number in the communication bus or in the local HMI, or by selecting the wanted setting group from *Control* → *Setting groups*. When the forcing parameter is enabled, the automatic control of the local device is overridden and the full control of the setting groups is given to the user until the "Force SG change" is disabled again.

Setting groups can be controlled either by pulses or by signal levels. The setting group controller block gives setting groups priority values for situations when more than one setting group is controlled at the same time: the request from a higher-priority setting group is taken into use.

Setting groups follow a hierarchy in which setting group 1 has the highest priority, setting group 2 has second highest priority etc. If a static activation signal is given for two setting groups, the setting group with higher priority will be active. If setting groups are controlled by pulses, the setting group activated by pulse will stay active until another setting groups receives and activation signal.

Figure. 4.4.16 - 84. Example sequences of group changing (control with pulse only, or with both pulses and static signals).

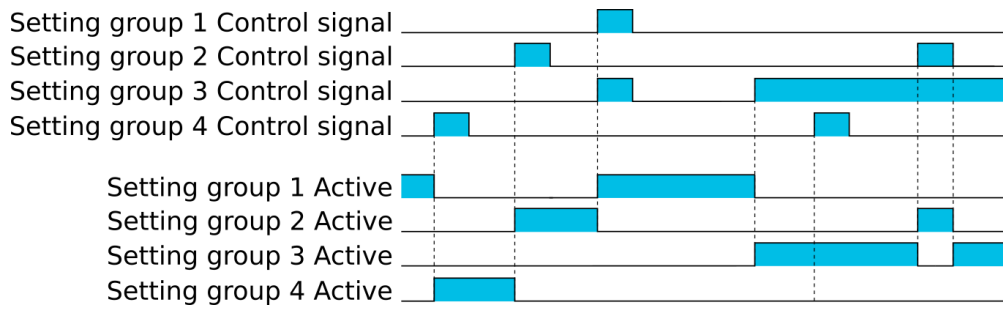

The settings of the setting group control function include the active setting group selection, the forced setting group selection, the enabling (or disabling) of the forced change, the selection of the number of active setting groups in the application, as well as the selection of the setting group changed remotely. If the setting group is forced to change, the corresponding setting group must be enabled and the force change must be enabled. Then, the setting group can be set from communications or from HMI to any available group. If the setting group control is applied with static signals right after the "Force SG" parameter is released, the application takes control of the setting group selection.

Table. 4.4.16 - 161. Settings of the setting group selection function.

| Name                       | Range  | Default  | Description   |
|----------------------------|--|----------|---|
| Active setting group       | <ul style="list-style-type: none"> <li>• SG1</li> <li>• SG2</li> <li>• SG3</li> <li>• SG4</li> <li>• SG5</li> <li>• SG6</li> <li>• SG7</li> <li>• SG8</li> </ul>                             | SG1      | Displays which setting group is active.   |
| Force setting group        | <ul style="list-style-type: none"> <li>• None</li> <li>• SG1</li> <li>• SG2</li> <li>• SG3</li> <li>• SG4</li> <li>• SG5</li> <li>• SG6</li> <li>• SG7</li> <li>• SG8</li> </ul>             | None     | The selection of the overriding setting group. After "Force SG change" is enabled, any of the configured setting groups in the device can be overridden. This control is always based on the pulse operating mode. It also requires that the selected setting group is specifically controlled to ON after "Force SG" is disabled. If there are no other controls, the last set setting group remains active. |
| Force setting group change | <ul style="list-style-type: none"> <li>• Disabled</li> <li>• Enabled</li> </ul>  | Disabled | The selection of whether the setting group forcing is enabled or disabled. This setting has to be active before the setting group can be changed remotely or from a local HMI. This parameter overrides the local control of the setting groups and it remains on until the user disables it.   |
| Used setting groups        | <ul style="list-style-type: none"> <li>• SG1</li> <li>• SG1...2</li> <li>• SG1...3</li> <li>• SG1...4</li> <li>• SG1...5</li> <li>• SG1...6</li> <li>• SG1...7</li> <li>• SG1...8</li> </ul> | SG1      | The selection of the activated setting groups in the application. Newly-enabled setting groups use default parameter values.  |

| Name                        | Range  | Default | Description   |
|-----------------------------|--|---------|---|
| Remote setting group change | <ul style="list-style-type: none"> <li>• None</li> <li>• SG1</li> <li>• SG2</li> <li>• SG3</li> <li>• SG4</li> <li>• SG5</li> <li>• SG6</li> <li>• SG7</li> <li>• SG8</li> </ul> | None    | This parameter can be controlled through SCADA to change the setting group remotely. Please note that if a higher priority setting group is being controlled by a signal, a lower priority setting group cannot be activated with this parameter. |

Table. 4.4.16 - 162. Signals of the setting group selection function.

| Name            | Description  |
|-----------------|--|
| Setting group 1 | The selection of Setting group 1 ("SG1"). Has the highest priority input in setting group control. Can be controlled with pulses or static signals. If static signal control is applied, no other SG requests will be processed.   |
| Setting group 2 | The selection of Setting group 2 ("SG2"). Has the second highest priority input in setting group control. Can be controlled with pulses or static signals. If static signal control is applied, no requests with a lower priority than SG1 will be processed.                          |
| Setting group 3 | The selection of Setting group 3 ("SG3"). Has the third highest priority input in setting group control. Can be controlled with pulses or static signals. If static signal control is applied, no requests with a lower priority than SG1 and SG2 will be processed.                   |
| Setting group 4 | The selection of Setting group 4 ("SG4"). Has the fourth highest priority input in setting group control. Can be controlled with pulses or static signals. If static signal control is applied, no requests with a lower priority than SG1, SG2 and SG3 will be processed.             |
| Setting group 5 | The selection of Setting group 5 ("SG5"). Has the fourth lowest priority input in setting group control. Can be controlled with pulses or static signals. If static signal control is applied, SG6, SG7 and SG8 requests will not be processed.  |
| Setting group 6 | The selection of Setting group 6 ("SG6"). Has the third lowest priority input in setting group control. Can be controlled with pulses or static signals. If static signal control is applied, SG7 and SG8 requests will not be processed.  |
| Setting group 7 | The selection of Setting group 7 ("SG7"). Has the second lowest priority input in setting group control. Can be controlled with pulses or static signals. If static signal control is applied, only SG8 requests will not be processed.  |
| Setting group 8 | The selection of Setting group 8 ("SG8"). Has the lowest priority input in setting group control. Can be controlled with pulses or static signals. If static signal control is applied, all other SG requests will be processed regardless of the signal status of this setting group. |

The setting group selection function block (abbreviated "SGS2" in event block names) generates events from its controlling status, its applied input signals, enabling and disabling of setting groups, as well as unsuccessful control changes. The events triggered by the function are recorded with a time stamp.

Table. 4.4.16 - 163. Event messages.

| Event block name | Event names                |
|------------------|----------------------------|
| SGS2             | SG2...SG8 Enabled/Disabled |

| Event block name | Event names                                |
|------------------|--|
| SGS2             | SG1...SG8 Request ON/OFF                   |
| SGS2             | Remote Change SG Request ON/OFF            |
| SGS2             | Local Change SG Request ON/OFF             |
| SGS2             | Force Change SG ON/OFF                     |
| SGS2             | SG Request Fail Not configured SG ON/OFF   |
| SGS2             | Force Request Fail Force ON/OFF            |
| SGS2             | SG Req. Fail Lower priority Request ON/OFF |
| SGS2             | SG1...SG8 Active ON/OFF                    |

#### 4.4.17 Generator/motor/transformer differential protection (I<sub>db</sub>/I<sub>di</sub>/I<sub>0dHV</sub>/I<sub>0dLV</sub>; 87T/87G/87M/87N)

The function is used for differential protection of two-winding transformers, motors and generators. Differential protection function is based on calculating the difference between the ingoing and outgoing currents. If the operating status is normal, all power that comes in also goes out. If this is not the case, the transformer has an internal fault and the device should be de-energized as soon as possible to avoid extensive damage to the protected object(s).

Differential protection is very sensitive and it is scaled internally to the loading and fault current flowing through the transformer. For example, an interturn fault in the transformer's windings could go entirely unnoticed by an overcurrent relay while a differential relay could trip it in the very first power cycle. The same goes for internal earth faults: they can be impossible for conventional earth fault protection to notice until the fault causes heavier fault currents (such as when the fault location is close to the neutral side inside the star winding).

Figure. 4.4.17 - 85. Differential protection function can be used for protecting transformers, machines (generators/motors) and both at the same time.

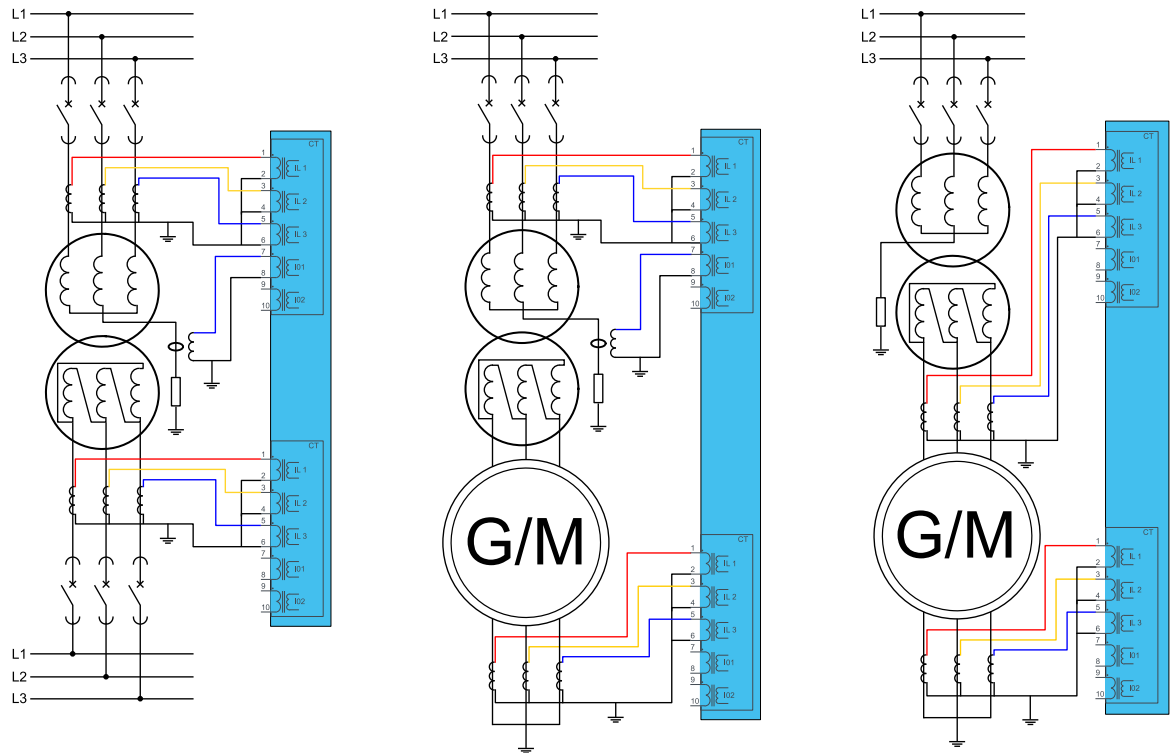

### Transformer properties and basic concepts for differential protection

Setting the differential protection requires some initial data of the transformer to be known. At minimum, the following data needs to be available:

- the transformer's nominal power
- the nominal voltages of the HV side and the LV side
- the transformer's special properties, such as tap changer and auxiliary windings
- the transformer's vector group (for matching the transformer vectors in p.u.)
- the ratios and properties of the transformers HV and LV sides.

This chapter shows the setting and the principle of transformer differential protection step by step.

Figure. 4.4.17 - 86. Transformer and its components forming the differential zone.

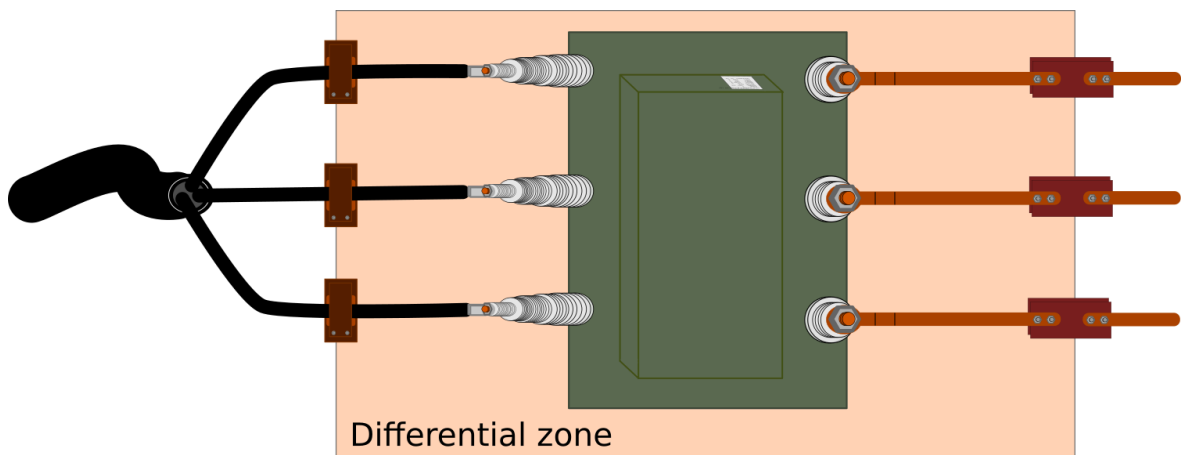

The differential protection area is the area between the current transformers. This is called the differential zone which means that the currents going in from one side must come out from the other side. This is true whether the signal is scaled higher or lower, or whether the phase angle is shifted. Unless both side currents match there is a problem within the protected zone which either blocks or keeps the current inside the zone.

Figure. 4.4.17 - 87. Transformer name plate data.

| MGT       |        | M.G.TRAFO & Sons. Co. Ltd. |  |
|-----------|--------|----------------------------|--|
| PHASE     | 3      |                            |  |
| POWER     | 2000   | kVA                        |  |
| VECTOR    | Yd1    |                            |  |
| IMP.Zk%   | 4.95   | %                          |  |
| VOLT.H.   | 10 000 | V                          |  |
| VOLT.L.   | 1000   | V                          |  |
| AMP.H.    | 116    | A                          |  |
| AMP.L.    | 1155   | A                          |  |
| FREQUENCY | 50     | Hz                         |  |

According to the data on this example name plate, this transformer is designed for three-phase usage and has two windings. The nominal power of the transformer is 2 MVA. Its vector group is Yd1: this means that the high-voltage side is connected to the Y and the low-voltage side to the delta, resulting in the LV side having a 30-degree lag in relation to the HV side. Additionally, the HV side's nominal voltage is 10 kV, on the LV side the nominal voltage is 1kV. The transformer's short-circuit impedance is 4.95 %; it is based on the transformer's final test and presents how much short-circuit current the transformer is able to feed. The transformer's frequency is 50 Hz. If the transformer has a tap changer, its information is usually also available in the name plate data.

Nominal current matching is the first thing to consider in differential protection. Modern numerical protection relays can calculate these factors themselves as long as the transformer's nominal power and voltage levels are known. However, if one feels inclined to calculate the amplitude matching factor, they can do so with the formulas presented below.

For this example, let us say we want to do these calculation for the transformer whose name plate we have in the image above. Let us further say the HV side current transformers are 150/5 A and the LV side current transformers are 1200/5 A. The primary side factor (p.u.) and current are then calculated as follows:

$$I_{n,HV} = \frac{S_n}{\sqrt{3} \times U_{HV}} = \frac{2\,000\,000\text{ VA}}{\sqrt{3} \times 10\,000\text{ V}} = 115.47\text{ A}$$

$$I_{pu,pri,HV} = \frac{I_{n,HV}}{CT_{pri,HV}} = \frac{115.47\text{ A}}{150\text{ A}} = 0.77$$

$$I_{pu,sec,HV} = I_{pu,pri,HV} \times CT_{sec,HV} = 0.77 \times 5\text{ A} = 3.85\text{ A}$$

Then, the secondary side factor (p.u.) and current are calculated as follows:

$$I_{n,LV} = \frac{S_n}{\sqrt{3} \times U_{LV}} = \frac{2\,000\,000\text{ VA}}{\sqrt{3} \times 1\,000\text{ V}} = 1154.7\text{ A}$$

$$I_{pu,pri,LV} = \frac{I_{n,LV}}{CT_{pri,LV}} = \frac{1154.7\text{ A}}{1200\text{ A}} = 0.96$$

$$I_{pu,sec,LV} = I_{pu,pri,LV} \times CT_{sec,LV} = 0.96 \times 5\text{ A} = 4.81\text{ A}$$

The calculations show that if 2 MVA of power go through the transformer the CT's secondary current on the high-voltage side will be 3.85 A and the CT secondary current on the low-voltage side will be 4.81 A. The differential function uses these values to change them into measured currents in per unit. Therefore, it would show  $1.0 \cdot I_n$  for both HV and LV side measurements, even though the measured currents are different. This is called amplitude matching of the HV and LV sides. In modern differential relays this is done automatically when the nominal values and CT ratings are set for the transformer. Thus, these calculations only have nice-to-know informational value.

Figure. 4.4.17 - 88. Amplitude scaling to match the nominal currents and CTs in the differential relay.

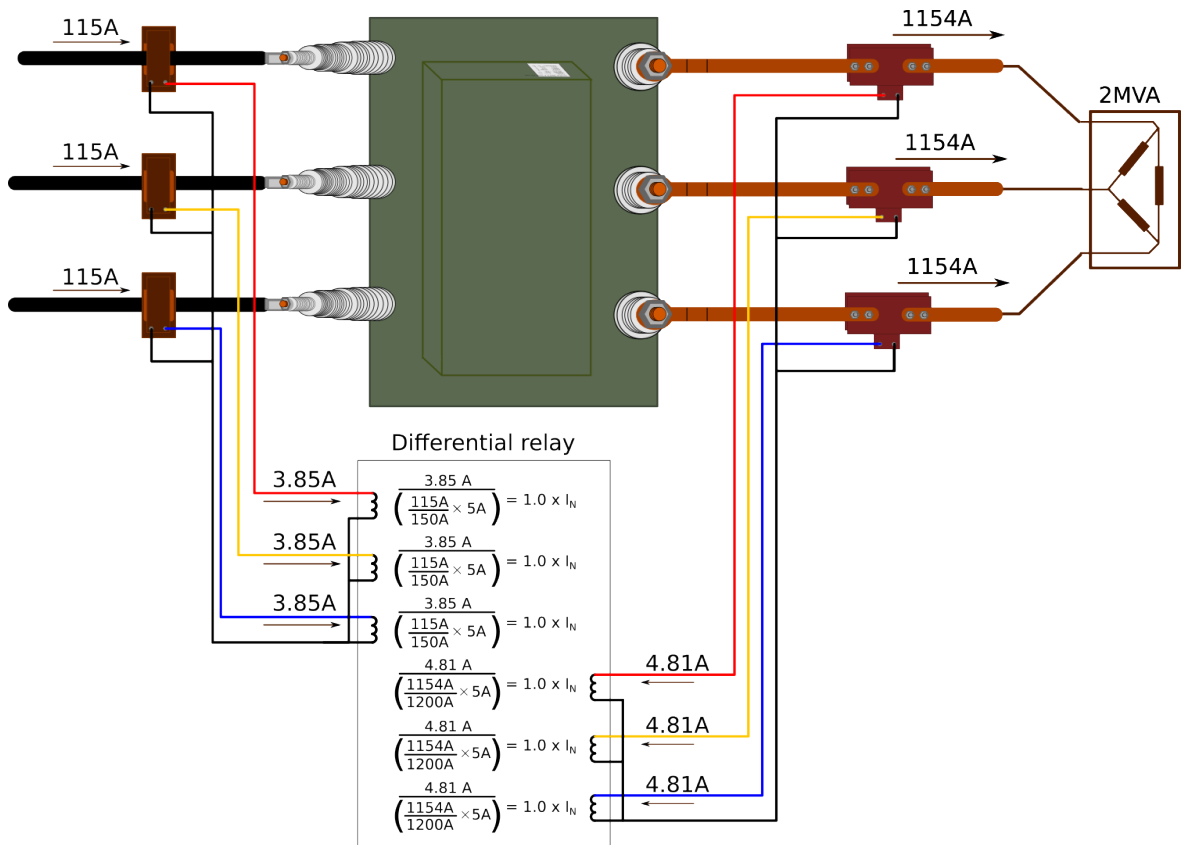

Nominal current matching is only part of the differential protection settings. The vector group of the transformer is also important, since the differential function is interested in the angle difference of the measured current vectors. In this example the transformer's vector group is Yd1, which means that the transformer's HV side is connected to the Y and the LV side to the delta. Therefore, the LV side is in 30-degree lag in relation to the HV side vectors.

The number '1' in the vector group's name comes from the angle in the phase current difference between the HV and the LV side. If one imagines the HV side current's Y placed upside down on the face of a clock (with the Y's leg pointing at 12), the LV side's delta would be pointing at 1. Likewise, '11' means that the LV side is leading 30 degrees; '5' and '7' are just the other ends of the windings thus causing a 180-degree difference between the '1' and '11' clock numbers.

The following example explains transformer current vectors and what a connection might look like.

Figure. 4.4.17 - 89. Yd1 transformer's internal connection (in theory).

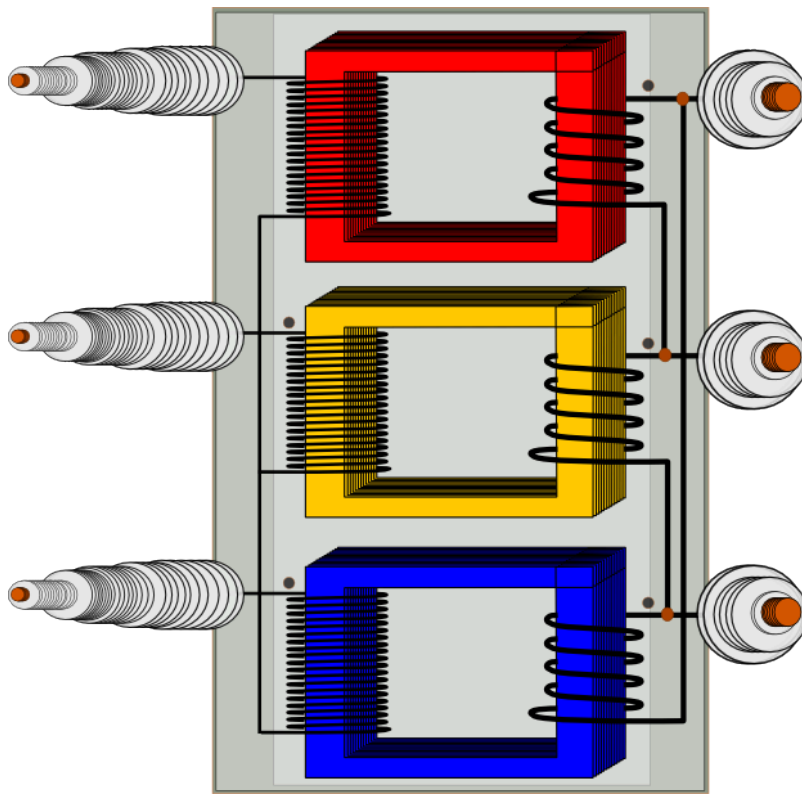

Yd1

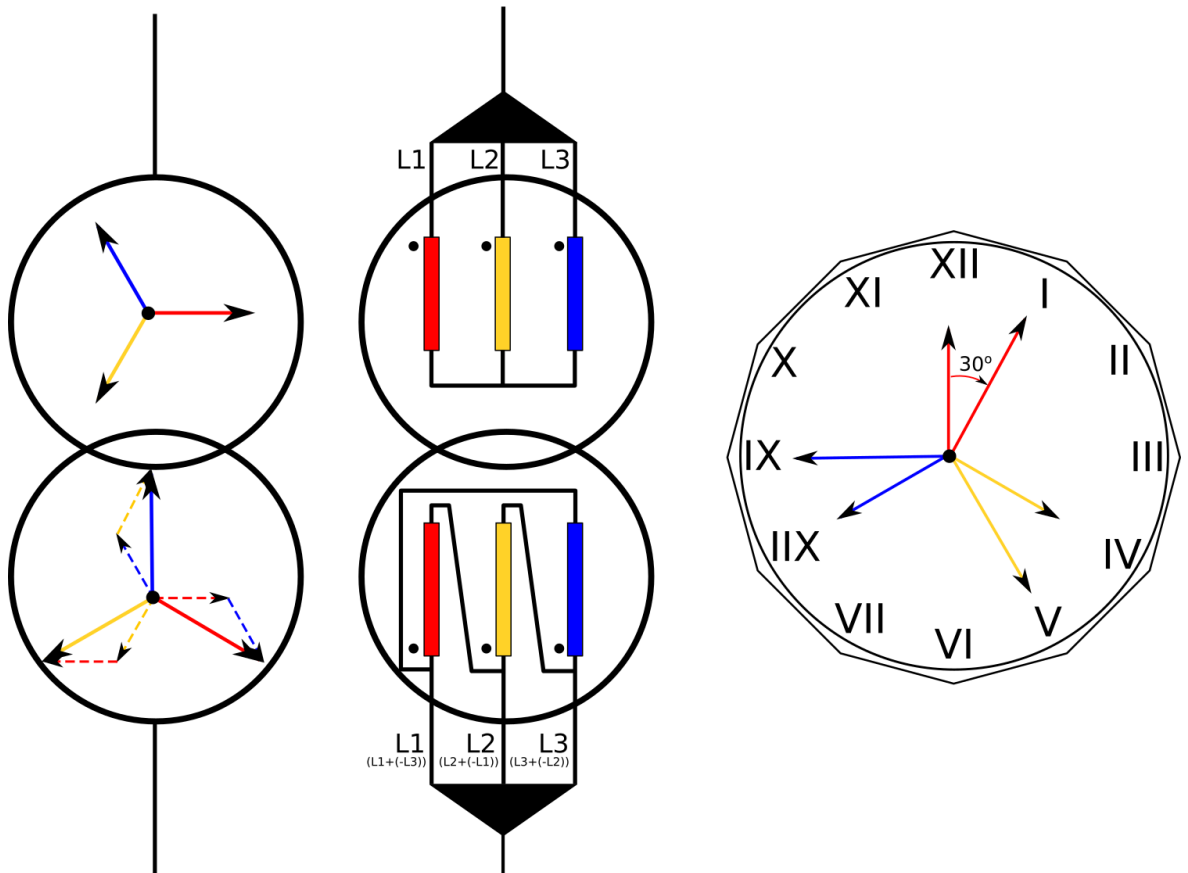

In modern protection relays these standard vector groups (Y or delta, lead or lag) are defined by a setting selection and there is no need for interposing transformers. Even if the transformer's vector group is not standard it should still be settable within the protection relay (such as with zigzag transformers).

In this example, the function translates the delta side currents. The correction applies not only to the angles but also to the amplitudes because the delta side (in p.u.) is relative to the amplitude difference with the Y-connected side.

$$\overline{IL1DS}_{LV} = \frac{(\overline{IL1}_{LV} - \overline{IL2}_{LV})}{\sqrt{3}}$$

$$\overline{IL2DS}_{LV} = \frac{(\overline{IL2}_{LV} - \overline{IL3}_{LV})}{\sqrt{3}}$$

$$\overline{IL3DS}_{LV} = \frac{(\overline{IL3}_{LV} - \overline{IL1}_{LV})}{\sqrt{3}}$$

This process is called vector group matching for the currents (in p.u.) of the transformer. This matching is necessary whenever one side is connected to the delta and another to the Y. Previously in non-numerical relays, this matching was done by interposing CTs which connected the power transformer's Y side to the delta, and the transformer's delta side to the Y. This got the HV and LV side vectors to match each other. Then the currents in the protection relay inputs are summed up. If there is no difference (as the HV and LV side currents negate each other), the pick-up is not triggered. If the currents do have a difference, the current flows to the protection relay input and with enough difference causes a pick-up and a trip. However, as modern differential relays do this transformation by calculating the corrected vector internally, this is also just nice-to-know information not related to the actual operation of the relay.

In Manual Set mode, the differential protection allows adjustment of the angle offset and a magnitude correction factor. If a winding side is configured as delta, the relay automatically applies the inherent 30° phase shift. This means the user must take that into account when calculating the additional manual angle offset. The magnitude correction is used to scale current magnitude's using the set factor. Phase remapping is not supported in this mode, so connection groups that rely on it (e.g. Yy2) cannot be used.

Figure. 4.4.17 - 90. Expected phase shifts from HV side to LV side (a symmetrical situation).

|                                    | Phase angles HV side |     |     |     | Phase angles LV side |      |      |  |
|------------------------------------|----------------------|-----|-----|-----|----------------------|------|------|--|
|                                    | Shift(deg)           | IL1 | IL2 | IL3 | IL1"                 | IL2" | IL3" |  |
| <b>Yy0, Yyn0, YNy0, Dd0</b>        | 0                    | 0   | 240 | 120 | 0                    | 240  | 120  |  |
| <b>Yy6, Yyn6, YNy6, YNyn6, Dd6</b> | 180                  | 0   | 240 | 120 | 180                  | 60   | 300  |  |
| <b>Yd1, YNd1, Dy1, Dyn1</b>        | -30                  | 0   | 240 | 120 | 330                  | 210  | 90   |  |
| <b>Yd11, YNd11, Dy11, Dyn11</b>    | 30                   | 0   | 240 | 120 | 30                   | 270  | 150  |  |
| <b>Yd5, YNd5, Dy5, Dyn5</b>        | -150                 | 0   | 240 | 120 | 210                  | 90   | 330  |  |
| <b>Yd7, YNd7, Dy7, Dyn7</b>        | 150                  | 0   | 240 | 120 | 150                  | 30   | 270  |  |

The direction of the CTs' Y legs on the HV and LV sides affects how the differential calculation method is set. The "add" mode is used when the CT's starpoints are either pointing towards each other or away from each other. The "subtract" mode is used when those points are pointing in the same direction. In this example above the correct setting would be the "add" mode because the CTs in the main circuit are connected to the opposite and thus the measured currents from the CTs are also opposite. The user selects how they want the signals to be shown: the CTs' currents can be negated with the "subtract" option, resulting in a one Y-connected vector diagram.

The images below present the differential algorithm itself; first the "subtract" formulas, then the "add" formulas.

Figure. 4.4.17 - 91. "Subtract" formula.

$$L1DIFF_{Subt} = |\overline{IL1_{HV}} - \overline{IL1_{LV}}|$$

$$L2DIFF_{Subt} = |\overline{IL2_{HV}} - \overline{IL2_{LV}}|$$

$$L3DIFF_{Subt} = |\overline{IL3_{HV}} - \overline{IL3_{LV}}|$$

Figure. 4.4.17 - 92. "Add" formula.

$$L1DIFF_{Add} = |\overline{IL1_{HV}} + \overline{IL1_{LV}}|$$

$$L2DIFF_{Add} = |\overline{IL2_{HV}} + \overline{IL2_{LV}}|$$

$$L3DIFF_{Add} = |\overline{IL3_{HV}} + \overline{IL3_{LV}}|$$

Figure. 4.4.17 - 93. CTs' starpoints requiring the "Add" mode.

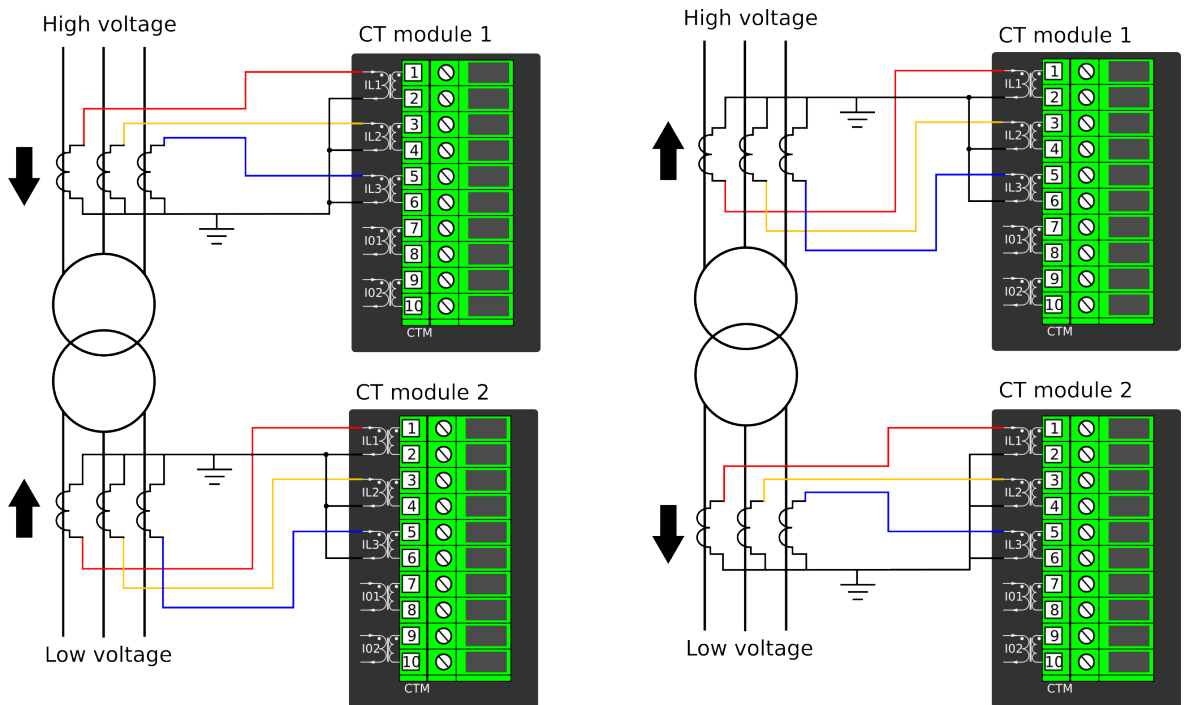
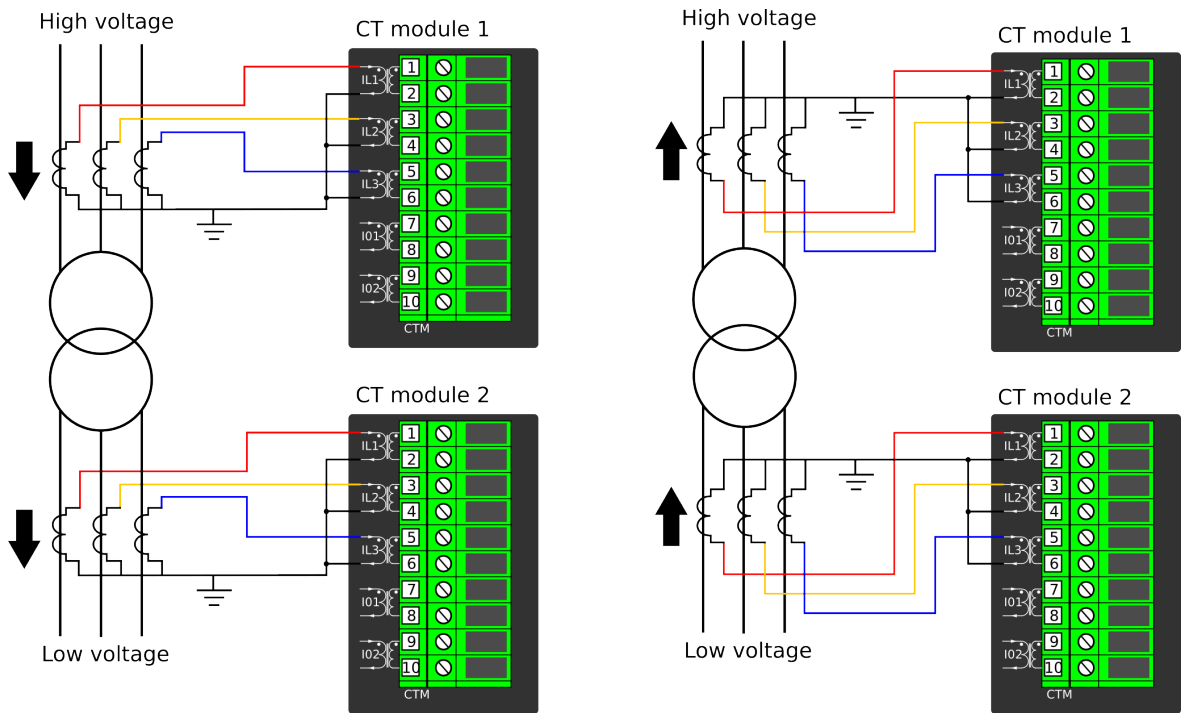

Figure. 4.4.17 - 94. CTs' starpoints requiring the "Subtract" mode.



The differential protection function has two separate operating stages:

- Non-restraint stage: This stage utilizes only the above mentioned comparison formulas as its evaluation basis.
- Restraint stage: In this stage, a *bias calculation* is performed for each phase. The purpose of this calculation is to adapt the sensitivity of the differential element to the magnitude of the measured currents, which improves stability under varying load and fault conditions.

Bias calculation can be sensitive or coarse (see the following formulas).

Figure. 4.4.17 - 95. Average mode (sensitive biasing).

$$L1BIAS_{AVG} = \frac{|IL1_{HV}| + |IL1_{LV}|}{2}$$

$$L2BIAS_{AVG} = \frac{|IL2_{HV}| + |IL2_{LV}|}{2}$$

$$L3BIAS_{AVG} = \frac{|IL3_{HV}| + |IL3_{LV}|}{2}$$

Figure. 4.4.17 - 96. Max mode (coarse biasing).

$$L1BIAS_{MAX} = \max(|IL1_{HV}|, |IL1_{LV}|)$$

$$L2BIAS_{MAX} = \max(|IL2_{HV}|, |IL2_{LV}|)$$

$$L3BIAS_{MAX} = \max(|IL3_{HV}|, |IL3_{LV}|)$$

Next, these two formulas (bias and differential calculation) are combined in a graph: the y-axis presents the measured differential current, and the x-axis presents the calculated bias current. The following graph shows the differential function characteristic, both biased and non-biased.

Figure. 4.4.17 - 97. Differential function characteristic, biased and non-biased.

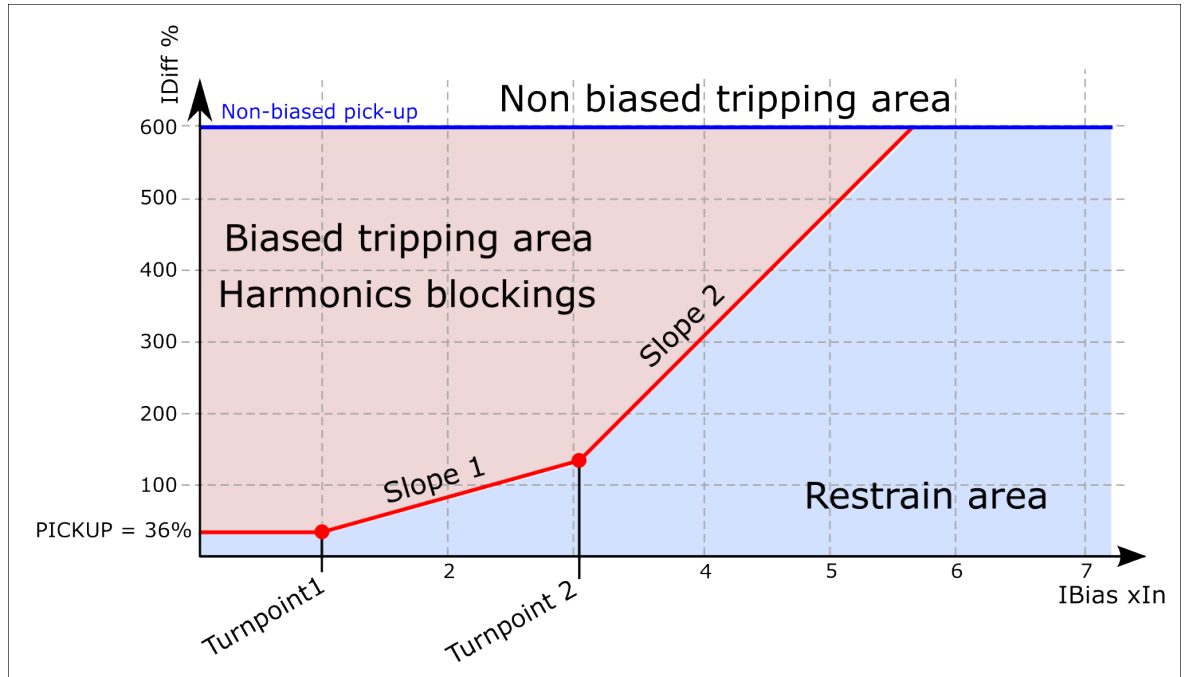

The graph is the function of measured biasing current and the differential protection current. The red line presents the allowed differential current in percentages. In this example the non-biased pick-up is set lower than in a normal transformer application. The settings and the ranges of the differential protection function are presented in the "Settings and signals" section of this topic.

The biasing characteristic is formed with the following formulas:

$$Diff_{bias < TP1} = I_{d > pick-up}$$

$$Diff_{bias TP1...TP2} = SL1 \times (Ix - TP1) + I_{d > pick-up}$$

$$Diff_{bias > TP2} = SL2 \times (Ix - TP2) + SL1 \times (TP2 - TP1) + I_{d > pick-up}$$

These form a straight line from zero current to Turnpoint (TP1). From TP1 to TP2 is the first slope (Slope 1) which causes the set biasing to be coarser when the measured current amplitude increases. When the measured current is higher than the TP2 set value, the second slope (Slope 2) is used.

### Differential characteristics settings

One needs to understand what the various parts of the characteristics mean in order to set the characteristics for the transformer application.

$$Diff_{bias < TP1} = I_{d > pick-up}$$

This is the first straight line which represents the differential current created by the transformer's normal operation. It takes into account measurement errors, possible variations caused by the transformer's tap changer (if available), and the various reasons why the application might have caused a different load inside the protected differential zone. In differential relays this is known as the pick-up current ( $I_{d>pick-up}$ ). It is the basic sensitivity limit: when the measured differential current is below this limit, the transformer still operates normally and the protection does not trigger. In other words, the pick-up current setting must be higher than the combination of all the normal operation factors that cause differential currents.

**Slope 1** settings present the protection relay's restrain characteristics over the transformer's load current range. This slope should be effective up to the maximum transformer loading. This value for power transformers is usually around  $1.0$  to  $2.0 \times I_n$ ; for large power transformer a typical value is  $1.5 \times I_n$ . The purpose is to compensate the measurement errors caused by a relatively high current, including the tap changer effect.

**Slope 2** settings are used for biasing the differential characteristics against heavy faults outside the differential zone that can cause heavy saturation on one or both sides of the CTs causing heavy differential current in the measurements even though the transformer itself does not have a fault.

**Calculating the generated differential current — The non-biased settings  $I_{d>Pick-up}$**

The purpose of this stage is to ensure fast and selective tripping of faults inside the differential zone, and also to ensure a stable operation on heavy outside faults. This stage operates only on the measured absolute differential current and is not blocked by harmonics or bias restraints. The setting of the stage should be based on the weakest full saturation of the CT under worst-case fault conditions because then only the other side current is measured and all current seen is differential current.

Figure. 4.4.17 - 98. Example differential characteristics

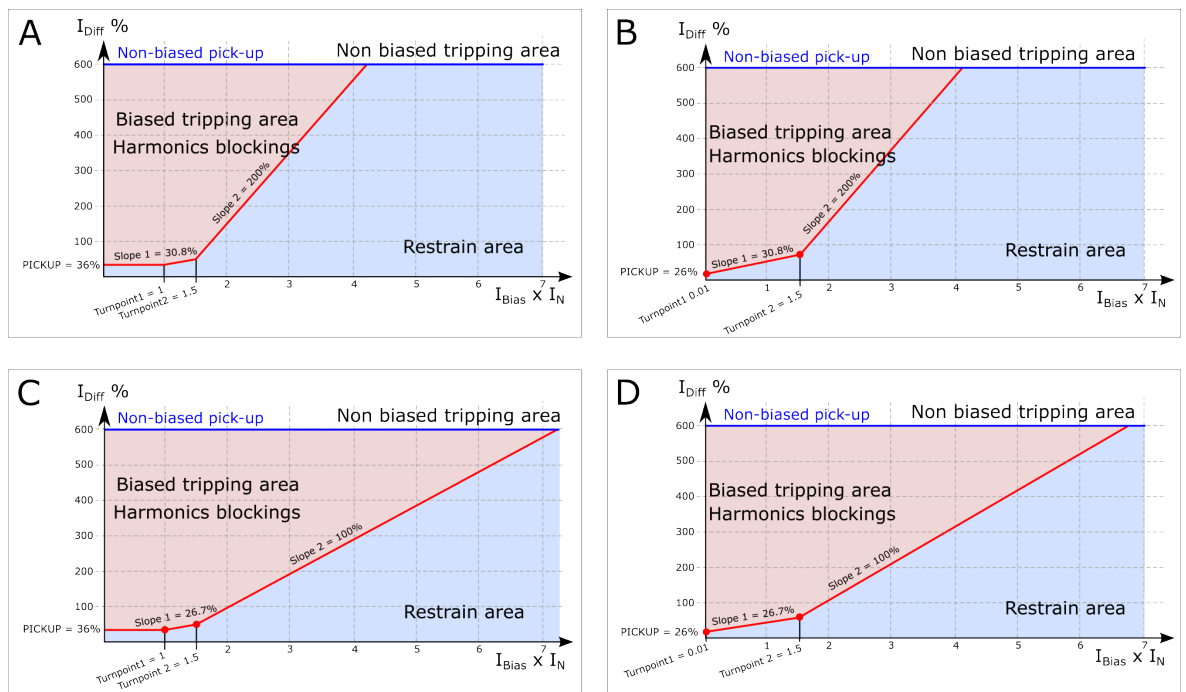

The four characteristics (the image above) present the setting variations based to the Average restraint calculation mode (figures A and B) and the Maximum restraint calculation modes (figures C and D). The characteristics are set to be equally sensitive in each of them. You can also see the variations in Turnpoint 1 settings: in Figures A and C it is set at  $1.0 \times I_n$ , whereas in Figures B and D it is set at  $0.01 \times I_n$ .

## Zero sequence compensation for external earth faults

A very common transformer type is the kind where the star side (HV, LV, or both) is earthed and thus forms a route outside the differential zone (see the image below).

Figure. 4.4.17 - 99. Transformer earthing settings that do not compensate for external earth faults.

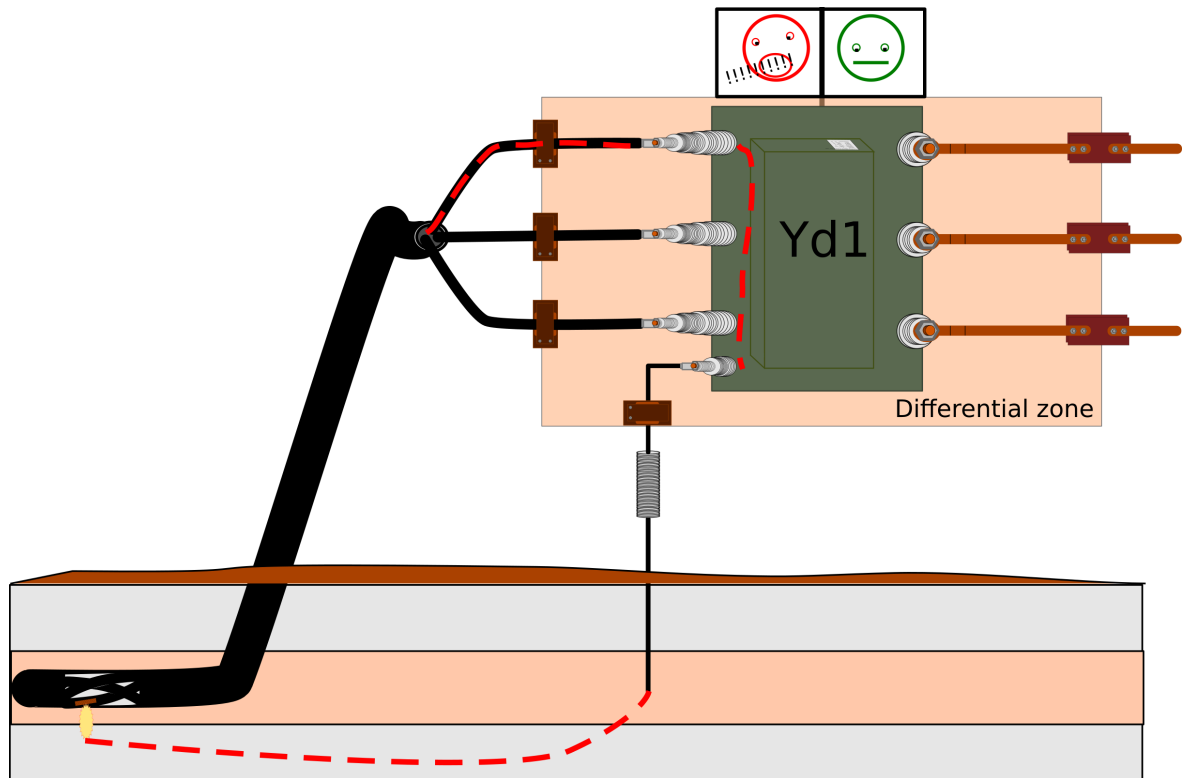

The differential relay looks at this situation and sees a fault inside the differential zone. This is because the other side is not affected at all by the fault (or only very little), and the relay sees a high current entering but not exiting the zone.

In many cases the zero sequence current is monitored by the CT in the earthing.

Earthing (directly or via a resistor) forms a route outside the differential zone.

When an external earth fault happens, only the earthed side of the transformer is involved in the fault.

The differential earthing requires the earthing to be known: if not compensated, any low-impedance earth fault outside the differential zone causes a differential current and possibly trips the differential protection. This is why the calculated zero sequence compensation is used. The vector group selection has either "N" or "n" to signify either HV side or LV side earthing. The selection then deducts the calculated zero sequence current from the currents (in p.u.) before differential calculation and thus negates the effect of an external earth fault. Correctly selected transformer settings prevent the differential function from being tripped by out-of-zone earth faults (see the image below).

Figure. 4.4.17 - 100. Transformer earthing settings that compensates for external earth faults.

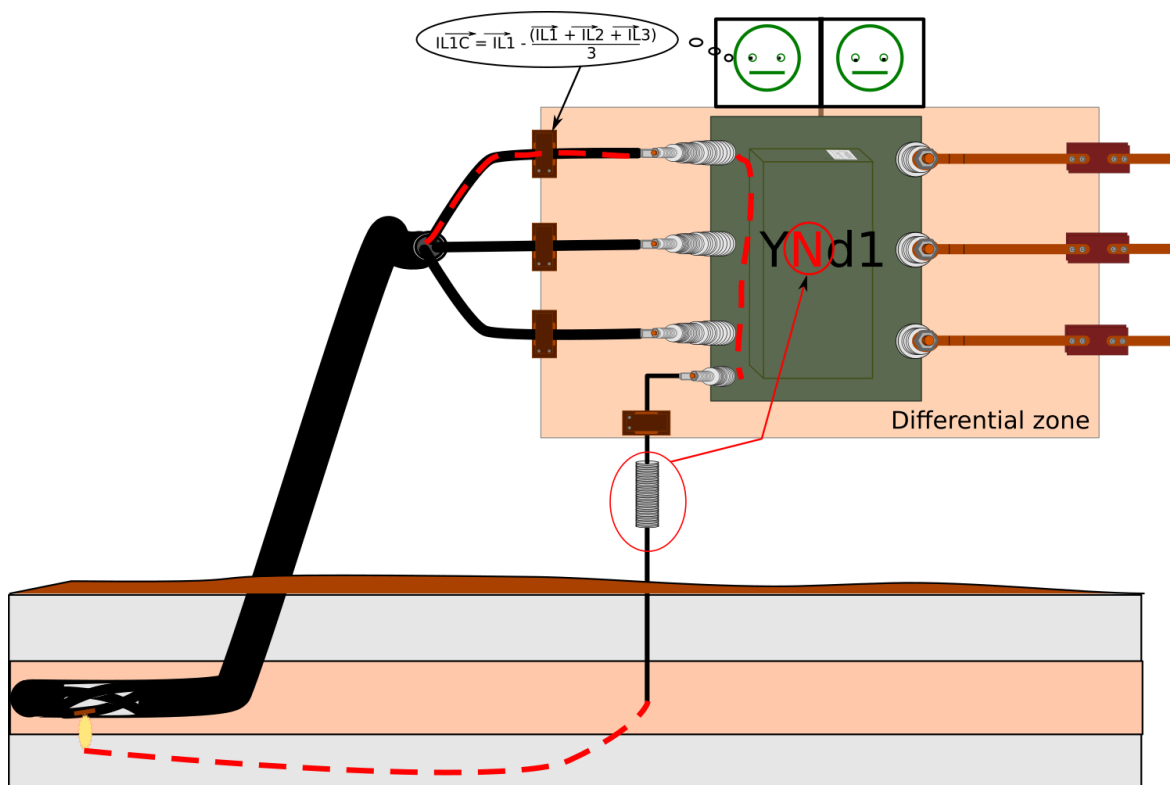

When the transformer settings are correct, the differential relay compensates the zero sequence current and does not trip due to earth faults outside the differential zone.

Earthing (directly or via a resistor) forms a route outside the differential zone.

When an external earth fault happens, only the earthed side of the transformer is involved in the fault.

The "N" or "n" selection applies the correction and eliminates the zero sequence effect with the following formulas:

$$\vec{I}_{L1_{corr}} = \vec{I}_{L1} - \frac{\vec{I}_{L1} + \vec{I}_{L2} + \vec{I}_{L3}}{3}$$

$$\vec{I}_{L2_{corr}} = \vec{I}_{L2} - \frac{\vec{I}_{L1} + \vec{I}_{L2} + \vec{I}_{L3}}{3}$$

$$\vec{I}_{L3_{corr}} = \vec{I}_{L3} - \frac{\vec{I}_{L1} + \vec{I}_{L2} + \vec{I}_{L3}}{3}$$

**Note!** When you enable the zero sequence compensation by selecting the "N" or "n" in the transformer vector group, the sensitivity to single-phase one end fault decreases by a third simultaneously. This is why restricted earth fault protection ( $I_{0>}$ , REF) should be enabled for the side where the zero sequence is compensated. However, enabling the REF protection requires that both the phase current measurements and the starpoint current are available and can be connected to the relay's residual current channel on the corresponding (HV/LV) side measurement.

## Restricted earth fault

When the transformer's earthed side is compensated with afore-mentioned zero sequence compensation, that side will be a third (appr. 33 %) less sensitive in detecting single-phase faults inside the differential zone. For this reason it is advised that the restricted earth fault (REF) stage is activated on the transformer side that compensates the zero sequence current. Additionally, it should be enabled whenever the Y side of the starpoint is earthed; normal phase differential protection cannot be set to provide the maximum sensitivity to detect single-phase (earth) faults within the differential area because the properties dependant on the transformer and the application that were described in the previous section. This differential stage monitors the incoming calculated residual current and compares it to the outgoing starpoint current. If the single-phase (earth) fault occurs outside the differential zone, this function does not operate; if the fault occurs inside the differential zone, this function operates quickly. This protection's sensitivity to earth faults only within the protection zone is referred to as the "restricted earth fault protection".

The transformer differential functions offers two stages of low-impedance, restricted earth fault protection.

The operating characters of the restricted earth fault function (I0d>) on both the high voltage and the low voltage side are more similar to each other than to the percentage characteristics presented by the Idb> function, even though both sides are independent and can be set freely. The calculation of differential and biasing currents on both sides is as follows (the HV side on the left, the LV side on the right).

|   |   |
|---|---|
| $HV_{I0d} \text{ bias avg} = \frac{ (\overline{IL1}_{HV} + \overline{IL2}_{HV} + \overline{IL3}_{HV}) + \overline{I0}_{HV \text{ meas}} }{2}$ | $LV_{I0d} \text{ bias avg} = \frac{ (\overline{IL1}_{LV} + \overline{IL2}_{LV} + \overline{IL3}_{LV}) + \overline{I0}_{LV \text{ meas}} }{2}$ |
| $HV_{I0d} \text{ bias max} = \max((\overline{IL1}_{HV} + \overline{IL2}_{HV} + \overline{IL3}_{HV}), \overline{I0}_{HV \text{ meas}})$        | $LV_{I0d} \text{ bias max} = \max((\overline{IL1}_{LV} + \overline{IL2}_{LV} + \overline{IL3}_{LV}), \overline{I0}_{LV \text{ meas}})$        |
| $HV_{I0d>} \text{ diff add} =  (\overline{IL1}_{HV} + \overline{IL2}_{HV} + \overline{IL3}_{HV}) + \overline{I0}_{HV \text{ meas}} $          | $LV_{I0d>} \text{ diff add} =  (\overline{IL1}_{LV} + \overline{IL2}_{LV} + \overline{IL3}_{LV}) + \overline{I0}_{LV \text{ meas}} $          |
| $HV_{I0d>} \text{ diff subtract} =  (\overline{IL1}_{HV} + \overline{IL2}_{HV} + \overline{IL3}_{HV}) - \overline{I0}_{HV \text{ meas}} $     | $LV_{I0d>} \text{ diff subtract} =  (\overline{IL1}_{LV} + \overline{IL2}_{LV} + \overline{IL3}_{LV}) - \overline{I0}_{LV \text{ meas}} $     |

Similarly to the phase differential stages, both sides with the restricted earth fault stages have options between the average and the maximum bias current calculation, as well as the option between the add and the subtract current calculation. The use of these stages depends on the CTs' installation directions and the desired sensitivity for bias calculation.

In the transformer differential stage the reference current for the REF protection is always the protected side nominal current, which is calculated in the relay's Transformer status monitoring (TRF) module.

## Blockings from harmonics (2<sup>nd</sup> and 5<sup>th</sup>)

In transformer protection harmonics are always present in energizing situations: they are generated by the high current in the transformer inductances when the coils are energized. They are also present in the currents during overfluxing and overvoltage situations. Energizing situations generate even harmonics: the 2<sup>nd</sup> harmonic is the most commonly used harmonic in inrush blocking. Overvoltage (and overexcitation) situations generate odd harmonics: the 5<sup>th</sup> harmonic is mainly used for blocking (the 3<sup>rd</sup> harmonic is also present in Y windings but absent in delta windings which is why the 5<sup>th</sup> harmonic has been chosen for overfluxing and excitation detection). In this chapter 'blocking' refers to the Idb> (the biased differential) stage and it has both these blocking (2<sup>nd</sup> and 5<sup>th</sup>) applied internally. If the Idi> stage (the non-biased differential) needs to be blocked, external blocking must be used.

## Differential function details

Figure. 4.4.17 - 101. Simplified function block diagram of the transformer differential function.

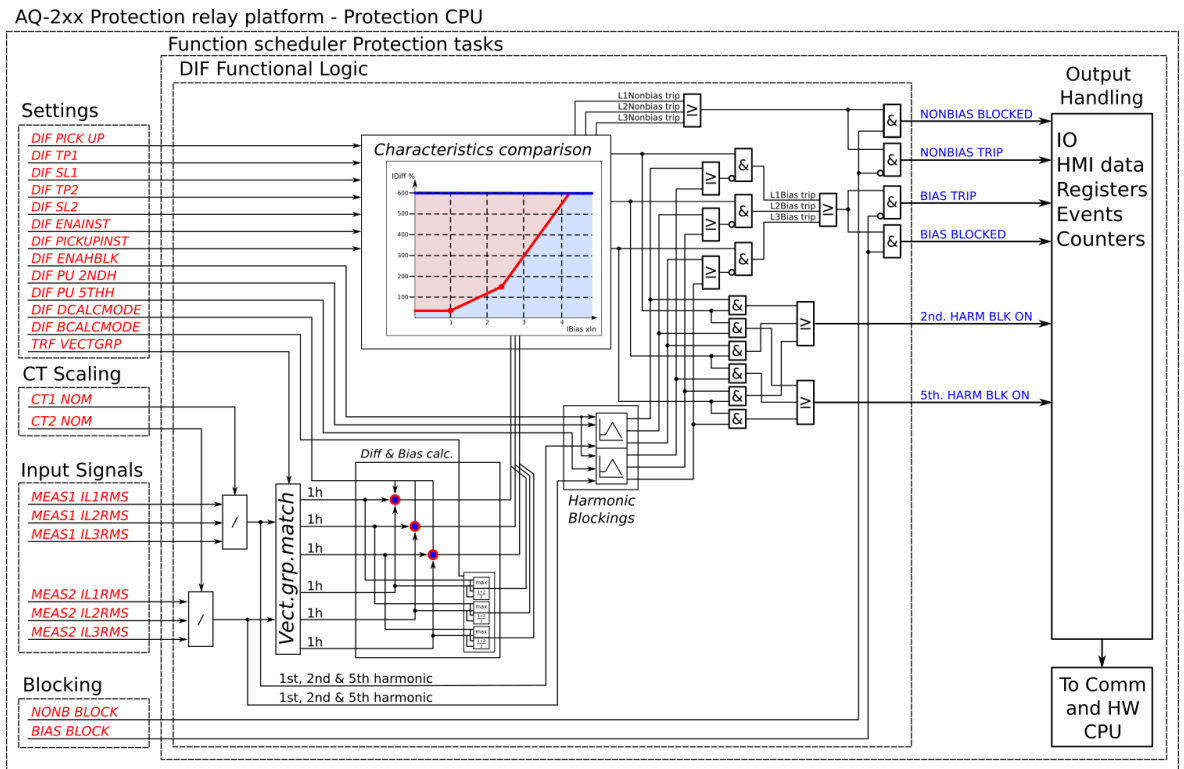

The transformer differential function outputs TRIP and BLOCKED signals from the biased and non-biased functions as well as the 2<sup>nd</sup> and 5<sup>th</sup> harmonic block activation signals. These signals can be used in protection applications.

## Settings and signals

The settings of the differential function are a combination of transformer monitor and differential stage function settings. The following table shows the function's settings, including the general settings (in p.u.) used for pre-calculations.

Table. 4.4.17 - 164. Settings related to the differential function's pre-calculation.

| Name         | Range  | Step | Default | Function | Description  |
|--------------|--|------|---------|----------|--|
| Idx> LN mode | <ul style="list-style-type: none"> <li>On</li> <li>Blocked</li> <li>Test</li> <li>Test/Blocked</li> <li>Off</li> </ul> | -    | On      | -        | Set mode of DIF block. This parameter is visible only when <i>Allow setting of individual LN mode</i> is enabled in <i>General</i> menu. |

| Name                    | Range  | Step   | Default | Function | Description   |
|-------------------------|--|--------|---------|----------|---|
| Idx> force status to    | <ul style="list-style-type: none"> <li>• Normal</li> <li>• ldb Blocked</li> <li>• ldb Trip</li> <li>• ldi Blocked</li> <li>• ldi Trip</li> <li>• H2block On</li> <li>• H5block On</li> <li>• HV I0d&gt; Block On</li> <li>• HV I0d&gt; Trip On</li> <li>• LV I0d&gt; Block On</li> <li>• LV I0d&gt; Trip On</li> </ul> | -      | Normal  | -        | Force the status of the function. Visible only when <i>Enable stage forcing</i> parameter is enabled in <i>General</i> menu.                      |
| Idx> LN behaviour       | <ul style="list-style-type: none"> <li>• On</li> <li>• Blocked</li> <li>• Test</li> <li>• Test/Blocked</li> <li>• Off</li> </ul>   | -      | -       | -        | Displays the mode of DIF block. This parameter is visible only when <i>Allow setting of individual LN mode</i> is enabled in <i>General</i> menu. |
| Transformer nominal     | 0.1...500.0MVA   | 0.1MVA | 1.0MVA  | All      | The nominal MVA of the transformer. This value is used to calculate the nominal currents onf both the HV and the LV side.                         |
| HV side nominal voltage | 0.1...500.0kV  | 0.1kV  | 110.0kV | All      | The HV side nominal voltage of the transformer. This value is used to calculate the nominal currents of the HV side.                              |
| LV side nominal voltage | 0.1...500.0kV  | 0.1kV  | 110.0kV | All      | The LV side nominal voltage of the transformer. This value is used to calculate the nominal currents of the LV side.                              |
| Transformer Zk%         | 0.01...25.00%  | 0.01%  | 3.00%   | Info     | The transformer's short-circuit impedance in percentages. Used for calculating short-circuit current.   |
| Transformer nom. freq.  | 10...75Hz  | 1Hz    | 50Hz    | Info     | The transformer's nominal frequency. Used for calculating the transformer's nominal short-circuit inductance.                                     |

| Name                          | Range  | Step | Default      | Function  | Description   |
|-------------------------------|--|------|--------------|---|---|
| Transf. vect. group           | <ul style="list-style-type: none"> <li>• Manual</li> <li>• Yy0</li> <li>• Yyn0</li> <li>• YNy0</li> <li>• YNyn0</li> <li>• Yy6</li> <li>• Yyn6</li> <li>• YNy6</li> <li>• YNyn6</li> <li>• Yd1</li> <li>• YNd1</li> <li>• Yd7</li> <li>• YNd7</li> <li>• Yd11</li> <li>• YNd11</li> <li>• Yd5</li> <li>• YNd5</li> <li>• Dy1</li> <li>• Dyn1</li> <li>• Dy7</li> <li>• Dyn7</li> <li>• Dy11</li> <li>• Dyn11</li> <li>• Dy5</li> <li>• Dyn5</li> <li>• Dd0</li> <li>• Dd6</li> </ul> | -    | Yy0          | <ul style="list-style-type: none"> <li>- transformer status monitoring</li> <li>- transformer differential</li> </ul> | <p>The selection of the transformer's vector group. The selection values (1–26) are predefined so that the scaling and vector matching are applied in the relay automatically when the correct vector group is selected.</p> <p>The predefinitions assume that the HV side is connected to the CT1 module and that the LV side is connected to the CT2 module.</p> <p>If the protected transformer vector group is not found in the predefined list, it can be manually set by selecting the option "Manual set".</p> |
| HV side Star or Zigzag/ Delta | <ul style="list-style-type: none"> <li>• Star/Zigzag</li> <li>• Delta</li> </ul>   | -    | Star/ Zigzag | <ul style="list-style-type: none"> <li>- transformer status monitoring</li> <li>- transformer differential</li> </ul> | <p>The selection of the HV side connection. Can be selected between star or zigzag and delta. This selection is visible only if the option "Manual set" is selected for the vector group setting.</p>   |
| HV side grounded              | <ul style="list-style-type: none"> <li>• Not grounded</li> <li>• Grounded</li> </ul>   | -    | Not grounded | <ul style="list-style-type: none"> <li>- transformer status monitoring</li> <li>- transformer differential</li> </ul> | <p>The selection of whether or not the zero sequence compensation is applied in the HV side current calculation. The selection is visible only if the option "Manual set" is selected for the vector group setting.</p>   |
| HV side lead or lag LV        | <ul style="list-style-type: none"> <li>• Lead</li> <li>• Lag</li> </ul>  | -    | Lead         | <ul style="list-style-type: none"> <li>- transformer status monitoring</li> <li>- transformer differential</li> </ul> | <p>The selection of whether the HV side leads or lags the LV side. The selection is visible only if the option "Manual set" is selected for the vector group setting.</p>   |
| LV side Star/ Zigzag or Delta | <ul style="list-style-type: none"> <li>• Star/Zigzag</li> <li>• Delta</li> </ul>   | -    | Star/ Zigzag | <ul style="list-style-type: none"> <li>- transformer status monitoring</li> <li>- transformer differential</li> </ul> | <p>The selection of the LV side connection. Can be selected between star or zigzag and delta. This selection is visible only if the option "Manual set" is selected for the vector group setting.</p>   |
| LV side grounded              | <ul style="list-style-type: none"> <li>• Not grounded</li> <li>• Grounded</li> </ul>   | -    | Not grounded | <ul style="list-style-type: none"> <li>- transformer status monitoring</li> <li>- transformer differential</li> </ul> | <p>The selection of whether or not the zero sequence compensation is applied in the LV side current calculation. The selection is visible only if the option "Manual set" is selected for the vector group setting.</p>   |

| Name                             | Range  | Step               | Default            | Function  | Description   |
|----------------------------------|--|--------------------|--------------------|---|---|
| LV side lead or lag HV           | <ul style="list-style-type: none"> <li>Lead</li> <li>Lag</li> </ul>                      | -                  | Lead               | - transformer status monitoring<br>- transformer differential | The selection of whether the LV side leads or lags the HV side. The selection is visible only if the option "Manual set" is selected for the vector group setting.  |
| HV-LV side phase angle           | 0.0...360.00deg  | 0.1deg             | 0.0deg             | - transformer status monitoring<br>- transformer differential | The angle correction factor for HV/LV sides, looked from the HV side. The setting is visible only if the option "Manual set" is selected for the vector group setting.  |
| HV-LV side mag correction        | 0.0...100.0×I <sub>n</sub>   | 0.1×I <sub>n</sub> | 1.0×I <sub>n</sub> | - transformer status monitoring<br>- transformer differential | The magnitude correction for the HV-LV side currents (in p.u.), if the currents are not directly matched through the calculations of the nominal values. The selection is visible only if the option "Manual set" for the vector group setting.   |
| Check online HV-LV configuration | <ul style="list-style-type: none"> <li>-</li> <li>Check</li> </ul>                       | -                  | -                  | - transformer status monitoring<br>- transformer differential | The selection of whether or not the function checks the current going through the transformer and then compares it to the settings. For this to work, the transformer needs to have a current flowing on both sides and "see" no faults. The selection is visible only if the option "Manual set" is selected for the vector group setting. |
| Enable I0d> (REF) HV side        | <ul style="list-style-type: none"> <li>Disabled</li> <li>Enabled</li> </ul>              | -                  | Disabled           | - transformer status monitoring<br>- transformer differential | The selection of whether the restricted earth fault stage on the HV side is enabled or disabled.  |
| HV side starpoint meas.          | <ul style="list-style-type: none"> <li>I<sub>01</sub></li> <li>I<sub>02</sub></li> </ul> | -                  | I <sub>01</sub>    | - transformer status monitoring<br>- transformer differential | The selection of the starpoint measurement channel for the restricted earth fault protection on the HV side. This setting is only visible if the option "Enabled" is selected for the "Enable I0d> (REF) HV side" setting.  |
| Enable I0d> (REF) LV side        | <ul style="list-style-type: none"> <li>Disabled</li> <li>Enabled</li> </ul>              | -                  | Disabled           | - transformer status monitoring<br>- transformer differential | The selection of whether the restricted earth fault stage on the LV side is enabled or disabled.  |
| LV side starpoint meas.          | <ul style="list-style-type: none"> <li>I<sub>01</sub></li> <li>I<sub>02</sub></li> </ul> | -                  | I <sub>01</sub>    | - transformer status monitoring<br>- transformer differential | The selection of the starpoint measurement channel for the restricted earth fault protection on the LV side. This setting is only visible if the option "Enabled" is selected for the "Enable I0d> (REF) LV side" setting.  |

Setting group selection controls the operating characteristics of the function, i.e. the user or user-defined logic can change function parameters while the function is running.

Table. 4.4.17 - 165. Settings for the operating characteristics.

| Name                                      | Range   | Step                | Default                           | Description   |
|---|---|---------------------|-----------------------------------|---|
| Differential calculation mode             | <ul style="list-style-type: none"> <li>Add</li> <li>Subtract</li> </ul>   | -                   | Subtract                          | The calculation mode of the differential current. The mode selection depends on the CTs' installation direction and the desired current directions. If the current flow on both sides is in the same direction, the differential current is subtracted. If the current flows are in the opposite directions, the differential current is added. |
| Bias calculation mode                     | <ul style="list-style-type: none"> <li>Average</li> <li>Maximum</li> </ul>  | -                   | Average                           | The calculation mode of the biasing current. With the average mode the operation may be set to be more sensitive. With the maximum mode the bias is always higher and thus provides a more stable operation.  |
| I <sub>db</sub> > Pick-up                 | 0.01...100.00%  | 0.01%               | 10.00%                            | The base sensitivity for the differential characteristics.  |
| Turnpoint 1                               | 0.01...50.00×I <sub>n</sub>   | 0.01×I <sub>n</sub> | 1.00×I <sub>n</sub>               | Turnpoint 1 for the differential characteristics.   |
| Slope 1                                   | 0.01...250.00%  | 0.01%               | 10.00%                            | Slope 1 for the differential characteristics.   |
| Turnpoint 2                               | 0.01...50.00×I <sub>n</sub>   | 0.01×I <sub>n</sub> | 3.00×I <sub>n</sub>               | Turnpoint 2 for the differential characteristics.   |
| Slope 2                                   | 0.01...250.00%  | 0.01%               | 200.00%                           | Slope 2 of the differential characteristics-  |
| Enable harmonic blocking                  | <ul style="list-style-type: none"> <li>No harmonic blocking</li> <li>2<sup>nd</sup> harmonic blocking</li> <li>5<sup>th</sup> harmonic blocking</li> <li>2<sup>nd</sup> and 5<sup>th</sup> harmonic blocking</li> </ul> | -                   | 2 <sup>nd</sup> harmonic blocking | The selection of the internal blockings to be used for the detection of transformer normal operations that cause differential currents.   |
| 2 <sup>nd</sup> harmonic blocking pick-up | 0.01...50.00%   | 0.01%               | 15.00%                            | The pick-up detection for the 2 <sup>nd</sup> harmonic blocking stage. This setting is only visible if the "Enable harmonic blocking" setting is set to "2nd harm" or "2nd and 5th harm".   |
| 5 <sup>th</sup> harmonic blocking pick-up | 0.01...50.00%   | 0.01%               | 35.00%                            | The pick-up detection for the 5 <sup>th</sup> harmonic blocking stage. This setting is only visible if the "Enable harmonic blocking" setting is set to "5th harm" or "2nd and 5th harm".   |
| 2nd harmonic maximum uptime               | 0.000...10.000 s  | 0.010 s             | 0.000 s                           | Determines the maximum time the detection of 2nd harmonic can block the operation of the function. Not in use when set to zero.   |
| 5th harmonic maximum uptime               | 0.000...10.000 s  | 0.010 s             | 0.000 s                           | Determines the maximum time the detection of 5th harmonic can block the operation of the function. Not in use when set to zero.   |

| Name                                | Range   | Step                | Default             | Description  |
|-------------------------------------|---|---------------------|---------------------|--|
| Enable I <sub>d</sub> > stage       | <ul style="list-style-type: none"> <li>Disabled</li> <li>Enabled</li> </ul> | -                   | Enabled             | The selection of whether the non-biased and the non-blocked differential stage is enabled or disabled.   |
| I <sub>d</sub> > Non-biased pick-up | 200.00...1500.00%   | 0.01%               | 600.00%             | The pick-up setting for the non-biased and non-blocked differential stage. This setting is only visible if the "Enable I <sub>d</sub> > stage" is disabled.                                |
| HV I <sub>0d</sub> > Pick-up        | 0.01...100.00%  | 0.01%               | 10.00%              | The base sensitivity for the HV side restricted earth fault differential characteristics. This setting is only visible if the "Enable I <sub>0d</sub> > (REF) HV side" setting is enabled. |
| HV I <sub>0d</sub> > Turnpoint 1    | 0.01...50.00×I <sub>n</sub>   | 0.01×I <sub>n</sub> | 1.00×I <sub>n</sub> | Turnpoint 1 for the HV side restricted earth fault differential characteristics. This setting is only visible if the "Enable I <sub>0d</sub> > (REF) HV side" setting is enabled.          |
| HV I <sub>0d</sub> > Slope 1        | 0.01...250.00%  | 0.01%               | 10.00%              | Slope 1 of the HV side restricted earth fault differential characteristics. This setting is only visible if the "Enable I <sub>0d</sub> > (REF) HV side" setting is enabled.               |
| HV I <sub>0d</sub> > Turnpoint 2    | 0.01...50.00×I <sub>n</sub>   | 0.01×I <sub>n</sub> | 3.00×I <sub>n</sub> | Turnpoint 2 for the HV side restricted earth fault differential characteristics. This setting is only visible if the "Enable I <sub>0d</sub> > (REF) HV side" setting is enabled.          |
| HV I <sub>0d</sub> > Slope 2        | 0.01...250.00%  | 0.01%               | 200.00%             | Slope 2 of the HV side restricted earth fault differential characteristics. This setting is only visible if the "Enable I <sub>0d</sub> > (REF) HV side" setting is enabled.               |
| LV I <sub>0d</sub> > Pick-up        | 0.01...100.00%  | 0.01%               | 10.00%              | The base sensitivity for the LV side restricted earth fault differential characteristics. This setting is only visible if the "Enable I <sub>0d</sub> > (REF) LV side" setting is enabled. |
| LV I <sub>0d</sub> > Turnpoint 1    | 0.01...50.00×I <sub>n</sub>   | 0.01×I <sub>n</sub> | 1.00×I <sub>n</sub> | Turnpoint 1 for the LV side restricted earth fault differential characteristics. This setting is only visible if the "Enable I <sub>0d</sub> > (REF) LV side" setting is enabled.          |
| LV I <sub>0d</sub> > Slope 1        | 0.01...250.00%  | 0.01%               | 10.00%              | Slope 1 of the LV side restricted earth fault differential characteristics. This setting is only visible if the "Enable I <sub>0d</sub> > (REF) LV side" setting is enabled.               |
| LV I <sub>0d</sub> > Turnpoint2     | 0.01...50.00×I <sub>n</sub>   | 0.01×I <sub>n</sub> | 3.00×I <sub>n</sub> | Turnpoint 2 for the LV side restricted earth fault differential characteristics. This setting is only visible if the "Enable I <sub>0d</sub> > (REF) LV side" setting is enabled.          |
| LV I <sub>0d</sub> > Slope 2        | 0.01...250.00%  | 0.01%               | 200.00%             | Slope 2 of the LV side restricted earth fault differential characteristics. This setting is only visible if the "Enable I <sub>0d</sub> > (REF) LV side" setting is enabled.               |

Table. 4.4.17 - 166. Calculations of the transformer differential function.

| Name   | Description                                  |
|--------|--|
| L1Bias | The calculated phase L1 bias current         |
| L2Bias | The calculated phase L2 bias current         |
| L3Bias | The calculated phase L3 bias current         |
| L1Diff | The calculated phase L1 differential current |

| Name                 | Description  |
|----------------------|--|
| L2Diff               | The calculated phase L2 differential current   |
| L3Diff               | The calculated phase L3 differential current   |
| L1Char               | The calculated phase L1 maximum differential current allowed with current bias level               |
| L2Char               | The calculated phase L1 maximum differential current allowed with current bias level               |
| L3Char               | The calculated phase L1 maximum differential current allowed with current bias level               |
| HV I0d> Bias current | The calculated HV side restricted earth fault bias current   |
| HV I0d> Diff current | The calculated HV side restricted earth fault differential current                                 |
| HV I0d> Char current | The calculated HV side restricted earth fault differential current allowed with current bias level |
| LV I0d> Bias current | The calculated LV side restricted earth fault bias current   |
| LV I0d> Diff current | The calculated LV side restricted earth fault differential current                                 |
| LV I0d> Char current | The calculated LV side restricted earth fault differential current allowed with current bias level |

Table. 4.4.17 - 167. Output signals of the transformer differential function.

| Name                               | Description  |
|------------------------------------|--|
| ldb> Bias Trip                     | The TRIP output signal from the biased differential stage  |
| ldi> Nobias Trip                   | The TRIP output signal from the non-biased and non-blocked differential stage                      |
| ldb> Bias Blocked                  | The BLOCKED output from the biased differential stage (external blocking)                          |
| ldi> Bias Blocked                  | The BLOCKED output from the non-biased and non-blocked differential stage (external blocking)      |
| ldb> 2 <sup>nd</sup> harm block on | The output of the 2 <sup>nd</sup> harmonic activation signal                                       |
| ldb> 5 <sup>th</sup> harm block on | The output of the 5 <sup>th</sup> harmonic activation signal                                       |
| HV I0d> Trip                       | The TRIP output signal from the biased restricted earth fault differential stage on the HV side    |
| HV I0d> Trip                       | The BLOCKED output signal from the biased restricted earth fault differential stage on the HV side |
| LV I0d> Trip                       | The TRIP output signal from the biased restricted earth fault differential stage on the LV side    |
| LV I0d> Trip                       | The BLOCKED output signal from the biased restricted earth fault differential stage on the LV side |

## Function blocking

The blocking signal is evaluated at the start of each program cycle. The blocking signals are connected to the function's dedicated input, which can be configured in the *IO* → *Blocking Input Control* tab of the function.

- When the pick-up element activates and the blocking signal is not active, a TRIP signal is generated.
- When the pick-up element activates and the blocking signal is active, a BLOCKED signal is generated, and the function does not process the event further.

The blocking signal needs to reach the device minimum of 5 ms before the set operating delay has passed in order for the blocking to activate in time.

## Events and registers

The transformer differential function (abbreviated "DIF" in event block names) generates events from the status changes in the events listed below. The user can select which event messages are stored in the main event buffer: ON, OFF, or both. The events triggered by the function are recorded with a time stamp.

The function's outputs can be used for direct I/O controlling and user logic programming. The function also provides a resettable cumulative counter for the TRIP, 2<sup>nd</sup> Harmonic Block, 5<sup>th</sup> Harmonic Block, External Block events.

Table. 4.4.17 - 168. Event messages.

| Event block name | Event names                           |
|------------------|---------------------------------------|
| DIF1             | ldb> Trip ON/OFF                      |
| DIF1             | ldb> Blocked (ext) ON/OFF             |
| DIF1             | ldi> Trip ON/OFF                      |
| DIF1             | ldi> Blocked (ext) ON/OFF             |
| DIF1             | 2 <sup>nd</sup> Harmonic Block ON/OFF |
| DIF1             | 5 <sup>th</sup> Harmonic Block ON/OFF |
| DIF1             | L1 2 <sup>nd</sup> harmonic ON/OFF    |
| DIF1             | L2 2 <sup>nd</sup> harmonic ON/OFF    |
| DIF1             | L3 2 <sup>nd</sup> harmonic ON/OFF    |
| DIF1             | L1 5 <sup>th</sup> harmonic ON/OFF    |
| DIF1             | L2 5 <sup>th</sup> harmonic ON/OFF    |
| DIF1             | L3 5 <sup>th</sup> harmonic ON/OFF    |
| DIF1             | HV I0d> Block ON/OFF                  |
| DIF1             | HV I0d> Trip ON/OFF                   |
| DIF1             | LV I0d> Block ON/OFF                  |

| Event block name | Event names         |
|------------------|---------------------|
| DIF1             | LV I0d> Trip ON/OFF |

The function registers its operation into the last twelve (12) time-stamped registers. The table below presents the structure of the function's register content.

Table. 4.4.17 - 169. Register content.

| Name                            | Description  |
|---------------------------------|--|
| Date and time                   | dd.mm.yyyy hh:mm:ss.mss                            |
| Event                           | Event name   |
| L1 bias current                 | Phase L1 bias current                              |
| L1 diff. current                | Phase L1 maximum differential current              |
| L1 char. current                | Phase L1 maximum differential current with bias    |
| L2 bias current                 | Phase L2 bias current                              |
| L2 diff. current                | Phase L2 maximum differential current              |
| L2 char. current                | Phase L2 maximum differential current with bias    |
| L3 bias current                 | Phase L3 bias current                              |
| L3 diff. current                | Phase L3 maximum differential current              |
| L3 char. current                | Phase L3 maximum differential current with bias    |
| HV I0d> bias current            | HV side REF bias current                           |
| HV I0d> differential current    | HV side REF differential current                   |
| HV I0d> characteristics current | HV side REF maximum differential current with bias |
| LV I0d> bias current            | LV side REF bias current                           |
| LV I0d> differential current    | LV side REF differential current                   |
| LV I0d> characteristics current | LV side REF maximum differential current with bias |
| Setting group in use            | Setting group in use                               |
| Ftype                           | Detected fault type (faulty phases)                |

## 4.4.18 Underimpedance protection ( $Z<$ ; 21U)

Underimpedance protection is an alternative for voltage-restrained overcurrent protection. It can be used to detect short-circuit faults near the generator even when the short-circuit current is small. Additionally, under impedance protection can be used as backup protection for transformer protection.

Figure. 4.4.18 - 102. Operating characteristics of underimpedance protection.

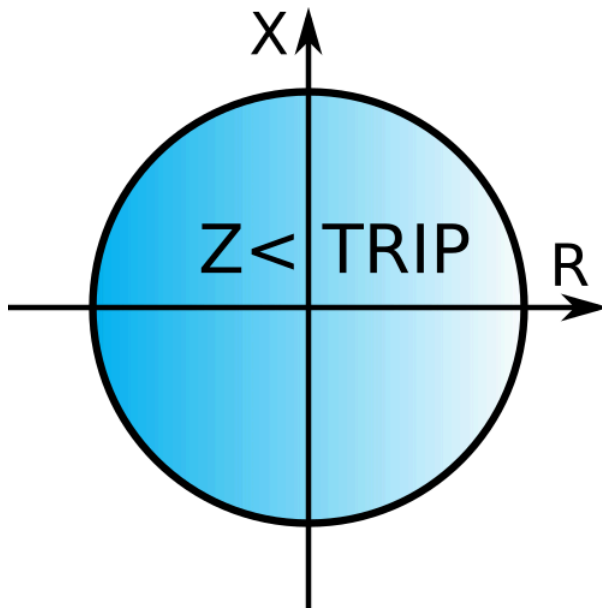
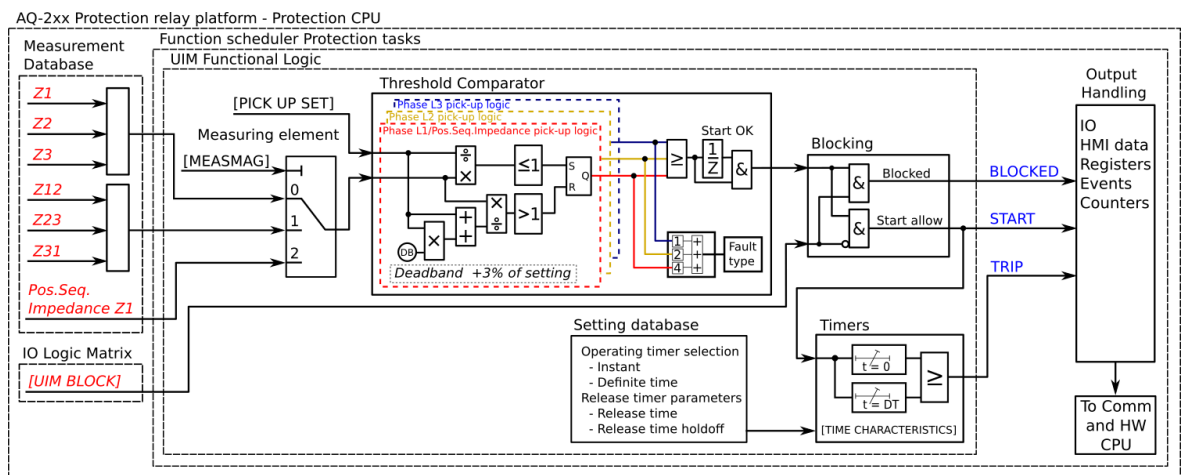

Figure. 4.4.18 - 103. Simplified function block diagram of the Z< function.



### Measured input

The function block uses phase currents and phase-to-phase or phase-to-neutral voltage measurement values. These values are used for calculating impedance.

Table. 4.4.18 - 170. Measurement inputs of the Z< function.

| Signal              | Description  |
|---------------------|--|
| I <sub>L1</sub> RMS | Fundamental frequency component of phase L1 (A) current              |
| I <sub>L2</sub> RMS | Fundamental frequency component of phase L2 (B) current              |
| I <sub>L3</sub> RMS | Fundamental frequency component of phase L3 (C) current              |
| U <sub>1</sub> RMS  | Fundamental frequency component of voltage channel U <sub>1</sub> /V |
| U <sub>2</sub> RMS  | Fundamental frequency component of voltage channel U <sub>2</sub> /V |

| Signal             | Description  |
|--------------------|--|
| U <sub>3</sub> RMS | Fundamental frequency component of voltage channel U <sub>3</sub> /V |
| U <sub>4</sub> RMS | Fundamental frequency component of voltage channel U <sub>4</sub> /V |

## General settings

The following general settings define the general behavior of the function. These settings are static i.e. it is not possible to change them by editing the setting group.

Table. 4.4.18 - 171. General settings of the function.

| Name               | Range  | Default       | Description   |
|--------------------|--|---------------|---|
| Z< LN mode         | <ul style="list-style-type: none"> <li>On</li> <li>Blocked</li> <li>Test</li> <li>Test/Blocked</li> <li>Off</li> </ul> | On            | Set mode of UIM block.<br>This parameter is visible only when <i>Allow setting of individual LN mode</i> is enabled in <i>General</i> menu. |
| Z< force status to | <ul style="list-style-type: none"> <li>Normal</li> <li>Start</li> <li>Trip</li> <li>Blocked</li> </ul>                 | Normal        | Force the status of the function. Visible only when <i>Enable stage forcing</i> parameter is enabled in <i>General</i> menu.                |
| Operation mode     | <ul style="list-style-type: none"> <li>P-E Impedances</li> <li>P-P Impedances</li> <li>Pos. seq. Impedance</li> </ul>  | P-E Impedance | Selects the used impedances.  |

## Pick-up settings

The  $Z_{set}(pri)<$  setting parameter controls the the pick-up of the Z< function. This defines the minimum allowed measured impedance before action from the function. The function constantly calculates the ratio between the impedance pick-up level and the calculated impedance for each of the three stages or the positive sequence impedance. The reset ratio of 103 % is built into the function and is always relative to the current pick-up value.

Setting group selection controls the operating characteristics of the function, i.e. the user or user-defined logic can change function parameters while the function is running.

Table. 4.4.18 - 172. Pick-up settings.

| Name            | Range          | Step  | Default | Description                               |
|-----------------|----------------|-------|---------|---|
| $Z_{set}(pri)<$ | 0.10...150.00Ω | 0.01Ω | 10Ω     | Pick-up setting as primary side impedance |

## Read-only parameters

The function's *Info* page displays useful, real-time information on the state of the protection function. It is accessed either through the device's HMI display, or through the setting tool software when it is connected to the device and its Live Edit mode is active.

Table. 4.4.18 - 173. Information displayed by the function.

| Name  | Range  | Step   | Description  |
|---|--|--------|--|
| Z < LN behaviour                                  | <ul style="list-style-type: none"> <li>On</li> <li>Blocked</li> <li>Test</li> <li>Test/Blocked</li> <li>Off</li> </ul> | -      | Displays the mode of UIM block.<br>This parameter is visible only when <i>Allow setting of individual LN mode</i> is enabled in <i>General</i> menu. |
| Z < condition                                     | <ul style="list-style-type: none"> <li>Normal</li> <li>Start</li> <li>Trip</li> <li>Blocked</li> </ul>                 | -      | Displays status of the protection function.  |
| Expected operating time                           | 0.000...1800.000s  | 0.005s | Displays the expected operating time when a fault occurs.  |
| Time remaining to trip                            | -1800.000...1800.000s  | 0.005s | When the function has detected a fault and counts down time towards a trip, this displays how much time is left before tripping occurs.              |
| Z <sub>meas</sub> /Z <sub>set</sub> at the moment | 0.00...1250.00   | 0.01   | The ratio between the lowest measured impedance and the pick-up value.   |

## Function blocking

The blocking signal is evaluated at the start of each program cycle. The blocking signals are connected to the function's dedicated input, which can be configured in the *IO* → *Blocking Input Control* tab of the function.

- When the pick-up element activates and the blocking signal is not active, a START signal is generated, and the function starts or continues with the trip time countdown.
- When the pick-up element activates and the blocking signal is active, a BLOCKED signal is generated, and the function does not process the event further.
- When a START signal is already active and the blocking input signal becomes active, the START signal is reset and BLOCKED signal is generated. The release time characteristics are then processed in the same way as when the pick-up signal is reset.

The blocking signal needs to reach the device minimum of 5 ms before the set operating delay has passed in order for the blocking to activate in time.

## Operating time characteristics for trip and reset

This function supports definite time delay (DT). For detailed information on these delay types please refer to the chapter "[General properties of a protection function](#)" and its section "[Operating time characteristics](#)".

## Events and registers

The underimpedance protection function (abbreviated "UIM" in event block names) generates events and registers from the status changes in the events listed below. The user can select which event messages are stored in the main event buffer: ON, OFF, or both. The events triggered by the function are recorded with a time stamp.

The function's outputs can be used for direct I/O controlling and user logic programming. The function also provides a resettable cumulative counter for the START, TRIP and BLOCKED events.

The function offers two (2) independent stages; the events are segregated for each stage operation.

Table. 4.4.18 - 174. Event messages.

| Event block name | Event names  |
|------------------|--------------|
| UIM1...UIM2      | Start ON/OFF |
| UIM1...UIM2      | Trip ON/OFF  |
| UIM1...UIM2      | Block ON/OFF |

The function registers its operation into the last twelve (12) time-stamped registers. The register of the function records the ON event process data for START, TRIP or BLOCKED. The table below presents the structure of the function's register content.

Table. 4.4.18 - 175. Register content.

| Register              | Description                |
|-----------------------|----------------------------|
| Date and time         | dd.mm.yyyy hh:mm:ss.mss    |
| Event                 | Event name                 |
| Fault type            | A-E...A-B-C                |
| Pre-trigger impedance | Start/Trip -20ms impedance |
| Fault impedance       | Start/Trip impedance       |
| Pre-fault impedance   | Start -200ms impedance     |
| Trip time remaining   | 0 ms...1800s               |
| Setting group in use  | Setting group 1...8 active |

## 4.4.19 Underexcitation protection (X<; 40)

Synchronous machines require a certain amount of excitation to stay stable. If the excitation drops too low a synchronous machine can drop out of step. One way for the protection relay to sense underexcitation is by measuring the impedance. When the measured impedance enters the defined circle, the function will trip.

Figure. 4.4.19 - 104. Underexcitation protection with impedance measurement.

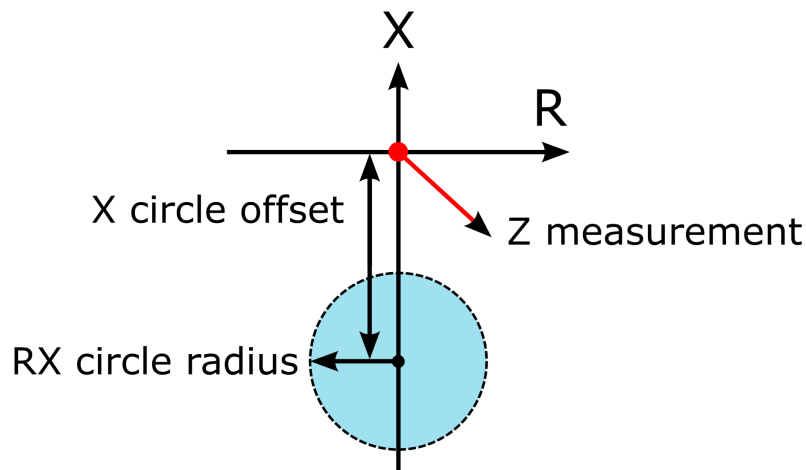

### Measured input

The function block uses phase currents and line-to-line or line-to-neutral voltages to calculate phase-to-phase impedance values, phase-to-neutral impedance values or positive sequence impedance values.

Table. 4.4.19 - 176. Measurement inputs of the X&lt; function.

| Signal                      | Description                                     |
|-----------------------------|---|
| Z1 Impedance loop           | Phase-to-neutral impedance loop                 |
| Z2 Impedance loop           | Phase-to-neutral impedance loop                 |
| Z3 Impedance loop           | Phase-to-neutral impedance loop                 |
| Z12 Impedance loop          | Phase-to-phase impedance loop                   |
| Z23 Impedance loop          | Phase-to-phase impedance loop                   |
| Z31 Impedance loop          | Phase-to-phase impedance loop                   |
| Positive sequence impedance | Pos.seq. impedance calculated from three phases |

### General settings

The following general settings define the general behavior of the function. These settings are static i.e. it is not possible to change them by editing the setting group.

Table. 4.4.19 - 177. General settings of the function.

| Name       | Range  | Default | Description   |
|------------|--|---------|---|
| X< LN mode | <ul style="list-style-type: none"> <li>• On</li> <li>• Blocked</li> <li>• Test</li> <li>• Test/Blocked</li> <li>• Off</li> </ul> | On      | Set mode of URX block.<br>This parameter is visible only when <i>Allow setting of individual LN mode</i> is enabled in <i>General</i> menu. |

| Name               | Range  | Default        | Description  |
|--------------------|--|----------------|--|
| X< force status to | <ul style="list-style-type: none"> <li>Normal</li> <li>Start</li> <li>Trip</li> <li>Blocked</li> </ul>                 | Normal         | Force the status of the function. Visible only when <i>Enable stage forcing</i> parameter is enabled in <i>General</i> menu. |
| Operation mode     | <ul style="list-style-type: none"> <li>P-E impedances</li> <li>Pos. Seq. impedances</li> <li>P-P impedances</li> </ul> | P-E impedances | Defines which available measurement is used by the function.   |

### Pick-up settings

The *X circle offset* and *RX circle radius* setting parameters control the pick-up of the X< function. This defines the tripping area of the function. The function constantly monitors the distance between the defined circle and the measured impedance. The reset ratio of 103 % is built into the function and is always relative to the RX circle radius.

Setting group selection controls the operating characteristics of the function, i.e. the user or user-defined logic can change function parameters while the function is running.

Table. 4.4.19 - 178. Pick-up settings.

| Name                   | Range                | Step     | Default    | Description  |
|------------------------|----------------------|----------|------------|--|
| X circle offset (pri)  | -50 000...50 000 Ohm | 0.01 Ohm | -50.00 Ohm | Sets the distance from origo to the edge of tripping area. |
| RX circle radius (pri) | 0.01...50 000 Ohm    | 0.01 Ohm | 50.00 Ohm  | Sets the radius of tripping area.                          |

### Read-only parameters

The function's *Info* page displays useful, real-time information on the state of the protection function. It is accessed either through the device's HMI display, or through the setting tool software when it is connected to the device and its Live Edit mode is active.

Table. 4.4.19 - 179. Information displayed by the function.

| Name            | Range  | Step | Description   |
|-----------------|--|------|---|
| X< LN behaviour | <ul style="list-style-type: none"> <li>On</li> <li>Blocked</li> <li>Test</li> <li>Test/Blocked</li> <li>Off</li> </ul> | -    | Displays the mode of URX block. This parameter is visible only when <i>Allow setting of individual LN mode</i> is enabled in <i>General</i> menu. |
| X< condition    | <ul style="list-style-type: none"> <li>Normal</li> <li>Start</li> <li>Trip</li> <li>Blocked</li> </ul>                 | -    | Displays the status of the protection function.   |

| Name                             | Range                               | Step              | Description   |
|----------------------------------|-------------------------------------|-------------------|---|
| Expected operating time          | 0.000...1800.000s                   | 0.005s            | Displays the expected operating time when a fault occurs.   |
| Time remaining to trip           | -1800.000...1800.000s               | 0.005s            | When the function has detected a fault and counts down time towards a trip, this displays how much time is left before tripping occurs. |
| $Z_{meas}/Z_{set}$ at the moment | -1250.00...1250.00<br>$Z_m/Z_{set}$ | $0.01Z_m/Z_{set}$ | The ratio between the measured impedance and the pick-up value.   |

### Function blocking

The blocking signal is evaluated at the start of each program cycle. The blocking signals are connected to the function's dedicated input, which can be configured in the *IO → Blocking Input Control* tab of the function.

- When the pick-up element activates and the blocking signal is not active, a START signal is generated, and the function starts or continues with the trip time countdown.
- When the pick-up element activates and the blocking signal is active, a BLOCKED signal is generated, and the function does not process the event further.
- When a START signal is already active and the blocking input signal becomes active, the START signal is reset and BLOCKED signal is generated. The release time characteristics are then processed in the same way as when the pick-up signal is reset.

The blocking signal needs to reach the device minimum of 5 ms before the set operating delay has passed in order for the blocking to activate in time.

### Operating time characteristics for trip and reset

This function supports definite time delay (DT). For detailed information on this delay type please refer to the chapter "[General properties of a protection function](#)" and its section "[Operating time characteristics](#)".

### Events and registers

The underexcitation function (abbreviated "URX" in event block names) generates events and registers from the status changes in the events listed below. The user can select which event messages are stored in the main event buffer: ON, OFF, or both. The events triggered by the function are recorded with a time stamp.

The function's outputs can be used for direct I/O controlling and user logic programming. The function also provides a resettable cumulative counter for the START, TRIP and BLOCKED events.

Table. 4.4.19 - 180. Event messages.

| Event block name | Event names  |
|------------------|--------------|
| URX1...URX2      | Start ON/OFF |
| URX1...URX2      | Trip ON/OFF  |
| URX1...URX2      | Block ON/OFF |

The function registers its operation into the last twelve (12) time-stamped registers. The register of the function records the ON event process data for START, TRIP or BLOCKED. The table below presents the structure of the function's register content.

Table. 4.4.19 - 181. Register content.

| Register                  | Description                |
|---------------------------|----------------------------|
| Date and time             | dd.mm.yyyy hh:mm:ss.mss    |
| Event                     | Event name                 |
| Pre-trigger impedance (Z) | Start/Trip -20ms impedance |
| Fault impedance (Z)       | Start/Trip impedance       |
| Pre-fault impedance (Z)   | Start -200ms impedance     |
| Trip time remaining       | 0 ms...1800s               |
| Setting group in use      | Setting group 1...8 active |

#### 4.4.20 Volts-per-hertz overexcitation protection (V/Hz>; 24)

Generators, transformers, and motors have their own, specific volts-per-hertz ratios under which these machines are expected to operate. Exceeding the V/Hz ratio results in machine overexcitation which causes iron core saturation in generators and transformers. This causes a breakdown of the insulation in the core's interlamination due to excessive voltage and eddy current heating. Additionally, stray flux is induced into non-laminated components which are not designed to carry flux-caused currents. In generators overexcitation typically occurs if the V/Hz ratio goes five percent above the nominal V/Hz ratio, with any possible damage happening within seconds. The most common situation for overexcitation is when a machine is off-line prior to synchronization.

The figure below shows how the pick-up settings and the measured frequency affect the pick-up level of the volts-per-hertz protection function.

Figure. 4.4.20 - 105. Effect of pick-up settings and the measured frequency to the overvoltage function's pick-up level.

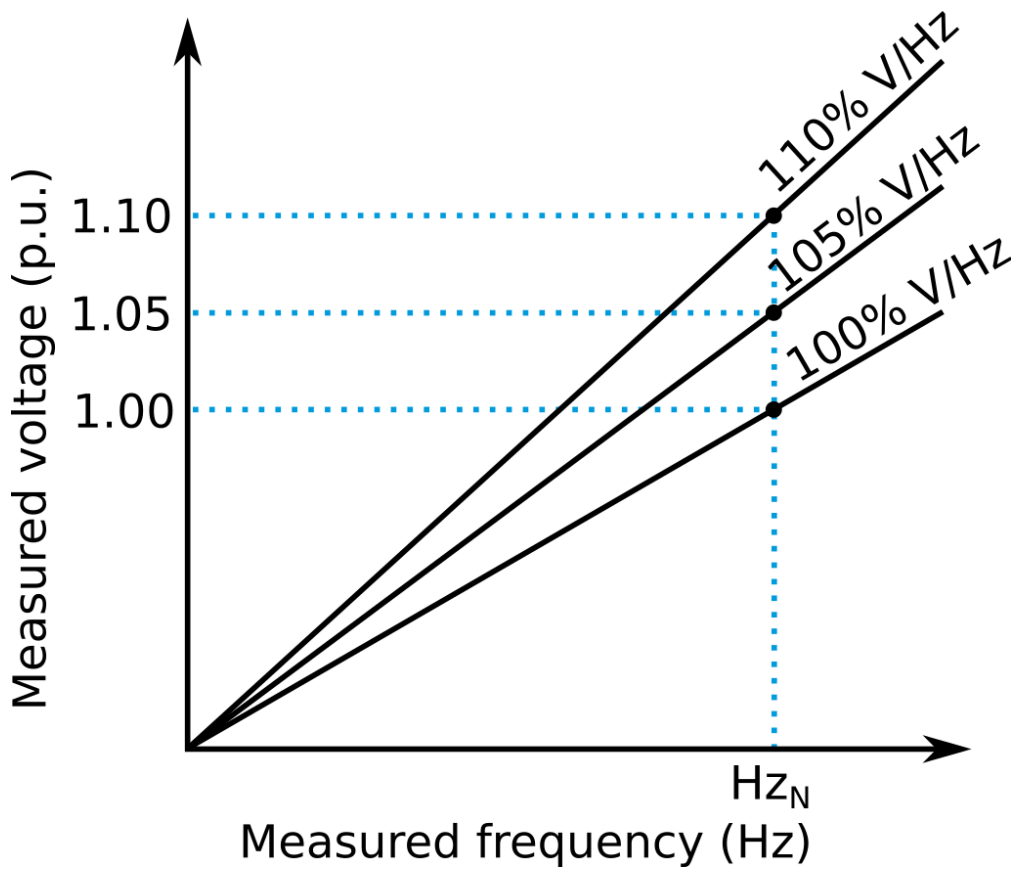
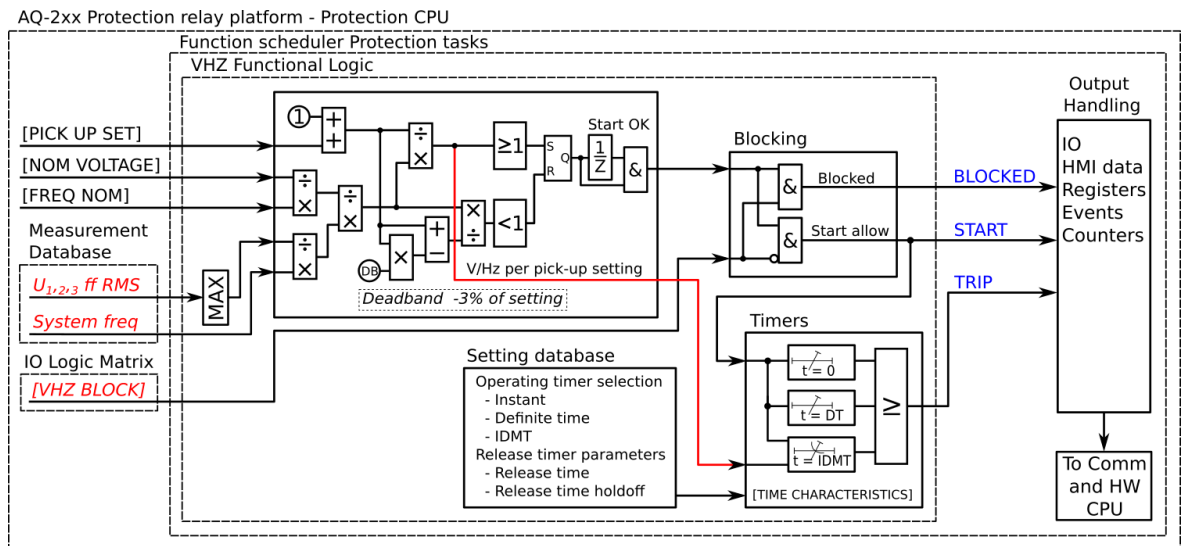



Figure. 4.4.20 - 106. Simplified function block diagram of the V/Hz> function.



### Measured input

The function block uses fundamental frequency component of phase-to-phase voltage measurements. Frequency measurement values is used for determining the overvoltage pick-up level. Please refer to "[Frequency tracking and scaling](#)" chapter for a detailed description of frequency tracking.



**NOTICE!**

The used sampling mode for frequency must be "Tracking".

Table. 4.4.20 - 182. Measurement inputs of the volts-per-hertz function.

| Signal                | Description  |
|-----------------------|--|
| U <sub>1</sub> RMS    | Fundamental frequency component of U <sub>1</sub> /V voltage channel |
| U <sub>2</sub> RMS    | Fundamental frequency component of U <sub>1</sub> /V voltage channel |
| U <sub>3</sub> RMS    | Fundamental frequency component of U <sub>1</sub> /V voltage channel |
| U <sub>4</sub> RMS    | Fundamental frequency component of U <sub>1</sub> /V voltage channel |
| Frequency reference 1 | Primary frequency reference  |
| Frequency reference 2 | Secondary frequency reference  |
| Frequency reference 3 | Tertiary frequency reference   |

### General settings

The following general settings define the general behavior of the function. These settings are static i.e. it is not possible to change them by editing the setting group.

Table. 4.4.20 - 183. General settings of the function.

| Name                   | Range  | Default | Description  |
|------------------------|--|---------|--|
| V/Hz > LN mode         | <ul style="list-style-type: none"> <li>On</li> <li>Blocked</li> <li>Test</li> <li>Test/Blocked</li> <li>Off</li> </ul> | On      | Set mode of VHZ block. This parameter is visible only when <i>Allow setting of individual LN mode</i> is enabled in <i>General</i> menu. |
| V/Hz > force status to | <ul style="list-style-type: none"> <li>Normal</li> <li>Start</li> <li>Trip</li> <li>Blocked</li> </ul>                 | Normal  | Force the status of the function. Visible only when <i>Enable stage forcing</i> parameter is enabled in <i>General</i> menu.             |

### Pick-up settings

Volts-per-hertz protection is based on the ratio between the maximum phase-to-phase voltage and the measured system frequency. The *Pick-up V/Hz > (% of nominal)* setting parameter controls the pick-up of the volts-per-hertz function. This defines the maximum measured voltage allowed in relation to the measured frequency before action from the function. The function constantly calculates the ratio between the *Pick-up V/Hz (% of nominal)* and the calculated  $U_{meas}/f_{meas}$  ratio. The reset ratio of 97 % is built into the function and is always relative to the *Pick-up V/Hz (% of nominal)* value.

Setting group selection controls the operating characteristics of the function, i.e. the user or user-defined logic can change function parameters while the function is running.

Table. 4.4.20 - 184. Pick-up settings.

| Name                          | Range   | Step   | Default | Description  |
|-------------------------------|---|--------|---------|--|
| Pick-up V/Hz > (% of nominal) | 0.01...30.00%   | 0.01%  | 5.00%   | The maximum allowed increase in the measured V/Hz ratio in relation to the nominal V/Hz ratio.   |
| Alarm delay (DT)              | 0.000...1800.000s   | 0.005s | 0.040s  | The definite operation time delay for alarm event.   |
| Delay type                    | <ul style="list-style-type: none"> <li>• DT</li> <li>• Inverse</li> <li>• DT and inverse</li> </ul> | -      | DT      | Selects the delay type(s) for the time counter.  |
| Time dial setting k           | 0.01...65.00  | 0.01   | 0.01    | Defines the time dial/multiplier setting for inverse curve characteristics.<br>This setting is active and visible when the "Delay type" parameter is set to "Inverse" or "DT and inverse".   |
| Definite operating time delay | 0.000...1800.000s   | 0.005s | 0.040s  | The definite operating time delay which is applied no matter how much the V/Hz ratio is exceeded.<br>This setting is only visible, when the selected delay type is "DT" or "DT and inverse". |

Inverse operating time characteristics are calculated according to the following equation:

$$t_{inverse} = DT_{set} + \frac{0.18 \times TimeDial\ k}{\left(\frac{V}{Hz_{measured}} - 1\right)^{IDMT\ multiplier}}$$

Figure. 4.4.20 - 107. Inverse (above) and inverse and DT (below) time characteristics with the TimeDial k setting effect.

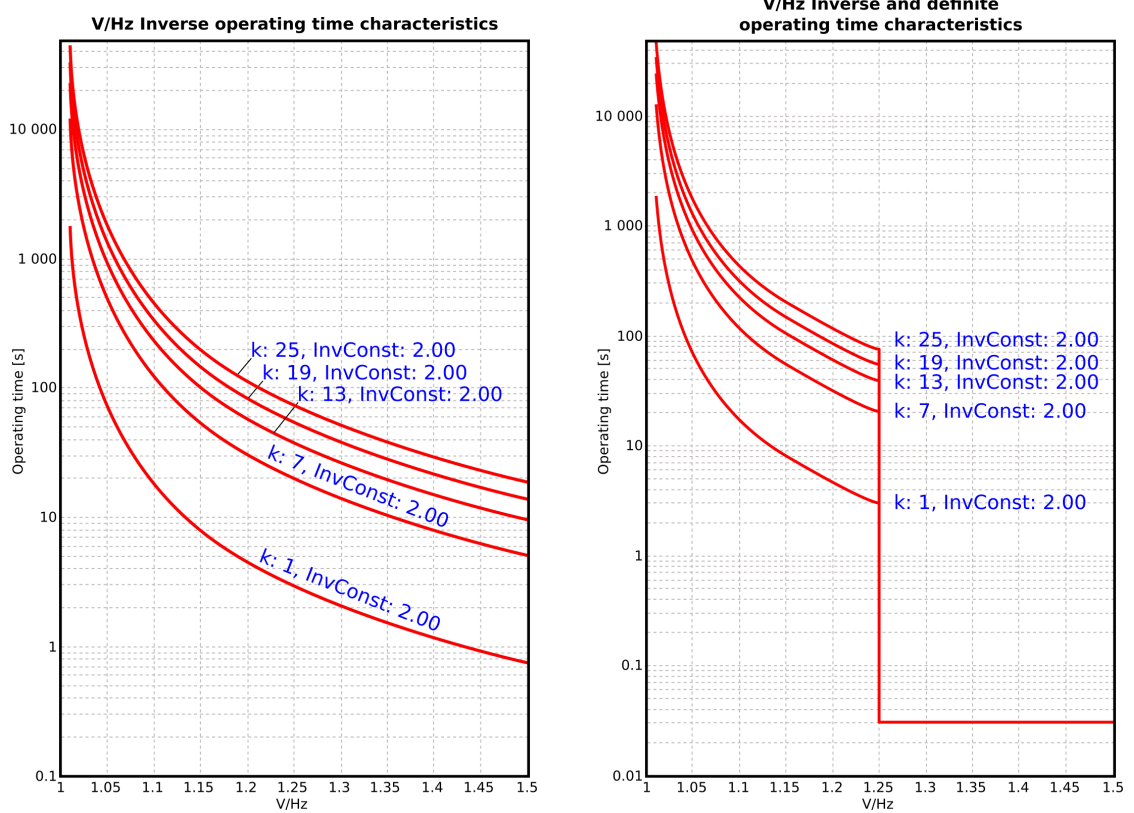
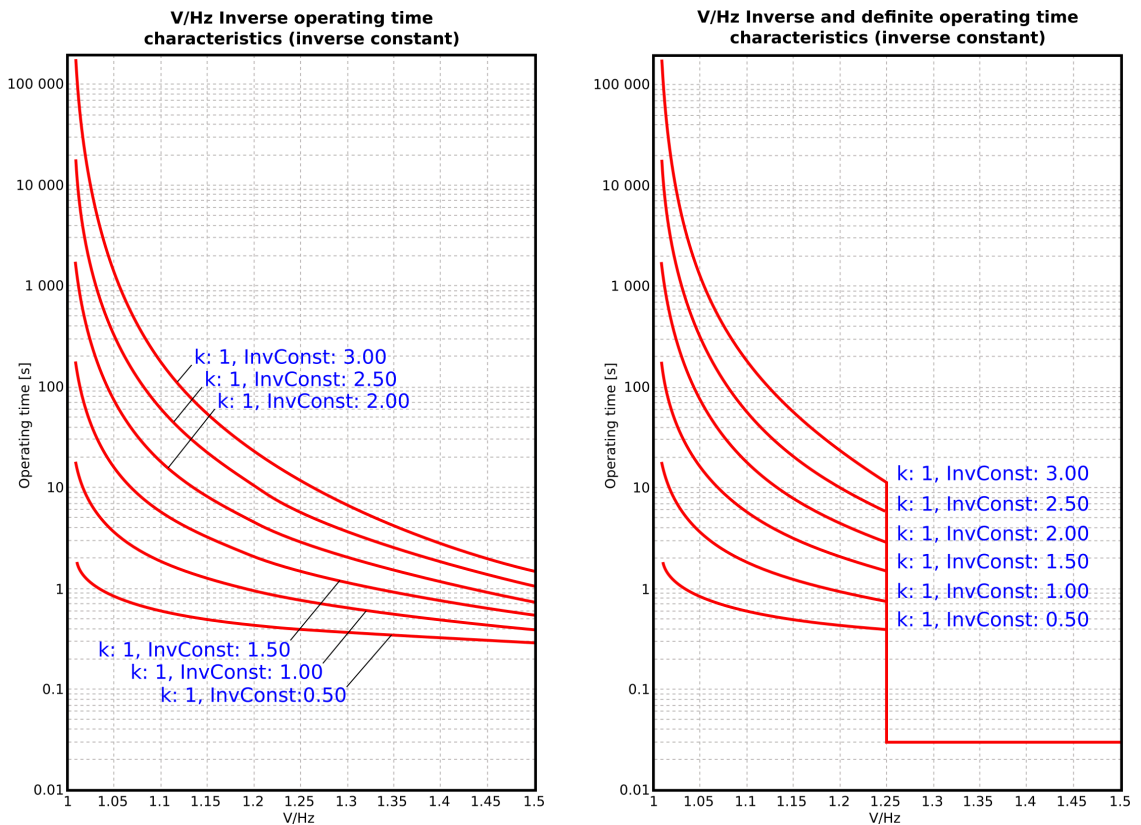

Figure. 4.4.20 - 108. Inverse (above) and inverse and DT (below) time characteristics with the inverse constant setting effect.



## Read-only parameters

The function's *Info* page displays useful, real-time information on the state of the protection function. It is accessed either through the device's HMI display, or through the setting tool software when it is connected to the device and its Live Edit mode is active.

Table. 4.4.20 - 185. Information displayed by the function.

| Name                         | Range  | Step                                 | Description   |
|------------------------------|--|--------------------------------------|---|
| V/Hz> LN behaviour           | <ul style="list-style-type: none"> <li>On</li> <li>Blocked</li> <li>Test</li> <li>Test/Blocked</li> <li>Off</li> </ul> | -                                    | Displays the mode of VHZ block. This parameter is visible only when <i>Allow setting of individual LN mode</i> is enabled in <i>General</i> menu. |
| V/Hz> condition              | <ul style="list-style-type: none"> <li>Normal</li> <li>Start</li> <li>Alarm</li> <li>Trip</li> <li>Blocked</li> </ul>  | -                                    | Displays the status of the protection function.   |
| Expected operating time      | 0.000...1800.000s  | 0.005s                               | Displays the expected operating time when a fault occurs.   |
| Time remaining to trip       | -1800.000...1800.000s  | 0.005s                               | When the function has detected a fault and counts down time towards a trip, this displays how much time is left before tripping occurs.           |
| U/f atm to pick-up U/f ratio | -100.00...100.00%  | 0.01P <sub>m</sub> /P <sub>set</sub> | The ratio between the measured power and the pick-up value.   |
| Nominal U/f                  | -100.000...100.000V/Hz   | 0.001V/Hz                            | Nominal volts-per-hertz ratio (voltage in per-unit value divided by nominal frequency). When 50Hz is used nominal U/f                             |
| U/f at the moment            | -100.000...100.000V/Hz   | 0.001V/Hz                            | Volts-per-hertz at the moment.  |
| U/f atm to nominal U/f ratio | -100.000...100.000V/Hz   | 0.001V/Hz                            | Measured volts-per-hertz ratio divided by nominal volts-per-hertz ratio.  |

## Function blocking

The blocking signal is evaluated at the start of each program cycle. The blocking signals are connected to the function's dedicated input, which can be configured in the *IO* → *Blocking Input Control* tab of the function.

- When the pick-up element activates and the blocking signal is not active, a START signal is generated, and the function starts or continues with the trip time countdown.
- When the pick-up element activates and the blocking signal is active, a BLOCKED signal is generated, and the function does not process the event further.
- When a START signal is already active and the blocking input signal becomes active, the START signal is reset and BLOCKED signal is generated. The release time characteristics are then processed in the same way as when the pick-up signal is reset.

The blocking signal needs to reach the device minimum of 5 ms before the set operating delay has passed in order for the blocking to activate in time.

## Events and registers

The volts-per-hertz overexcitation protection function (abbreviated "VHZ" in event block names) generates events and registers from the status changes in the events listed below. The user can select which event messages are stored in the main event buffer: ON, OFF, or both. The events triggered by the function are recorded with a time stamp.

The function's outputs can be used for direct I/O controlling and user logic programming. The function also provides a resettable cumulative counter for the START, TRIP and BLOCKED events.

The function offers one (1) stage

Table. 4.4.20 - 186. Event messages.

| Event block name | Event names               |
|------------------|---------------------------|
| VHZ1             | V/Hz (1...2) Start ON/OFF |
| VHZ1             | V/Hz (1...2) Alarm ON/OFF |
| VHZ1             | V/Hz (1...2) Trip ON/OFF  |
| VHZ1             | V/Hz (1...2) Block ON/OFF |

The function registers its operation into the last twelve (12) time-stamped registers. The register of the function records the ON event process data for START, TRIP or BLOCKED. The table below presents the structure of the function's register content.

Table. 4.4.20 - 187. Register content.

| Name                          | Description                |
|-------------------------------|----------------------------|
| Date and time                 | dd.mm.yyyy hh:mm:ss.mss    |
| Event                         | Event name                 |
| Voltages (AB/BC/CA) pre-trig  | Start/Trip -20ms voltages  |
| Frequency pre-trig            | Start/Trip -20ms frequency |
| Voltages (AB/BC/AC) fault     | Start/Trip voltages        |
| Frequency fault               | Start/Trip frequency       |
| Voltages (AB/BC/AC) pre-fault | Start -200ms voltages      |
| Frequency pre-fault           | Start -200ms frequency     |
| Trip time remaining           | 0 ms...1800 s              |
| Setting group in use          | Setting group 1...8 active |

### 4.4.21 Pole slip protection (78)

Pole slipping is a phenomenon where synchronism is lost due to power swings. This can happen in extreme fault conditions which cause a transient torque on the machine. Generators might experience this if it has low excitation, because it produces a weak magnetic field. The "slip" occurs when rotor electrically and physically shifts in relation to the stator, after which the field returns the rotor back in sync with the stator. This causes high acceleration and deceleration causes stress on the generator and prime mover, which can cause winding movement, shaft fracture or worse.

Figure. 4.4.21 - 109. Operating characteristics of pole slip protection.

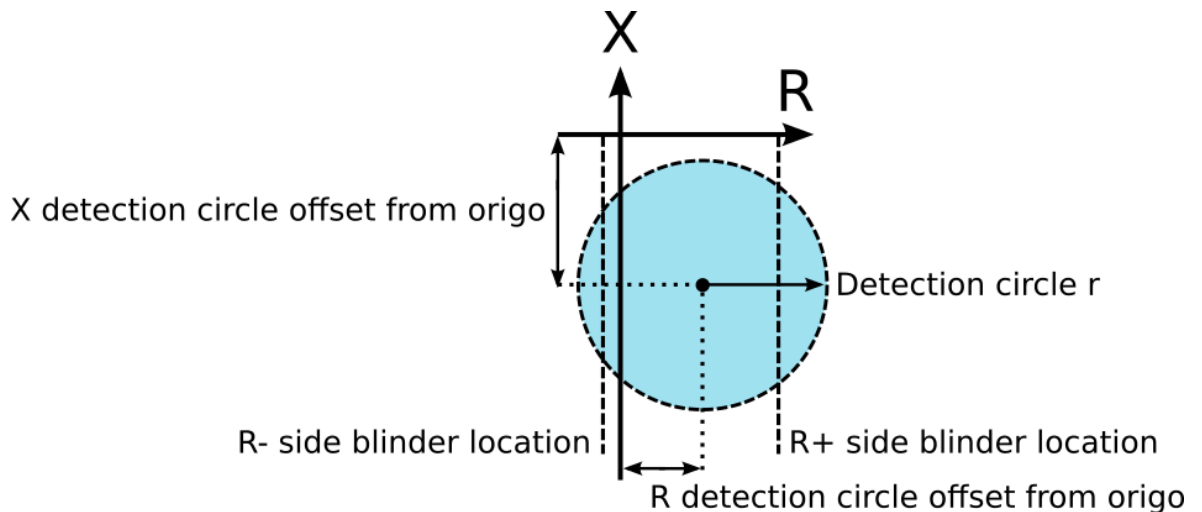

#### Measured input

The function block uses phase currents and phase-to-phase or phase-to-neutral voltage measurement values. These values are used for calculating positive sequence impedance.

Table. 4.4.21 - 188. Measurement inputs of the pole slip protection function.

| Signal      | Description  |
|-------------|--|
| $I_{L1RMS}$ | Fundamental frequency component of phase L1 (A) current    |
| $I_{L2RMS}$ | Fundamental frequency component of phase L2 (B) current    |
| $I_{L3RMS}$ | Fundamental frequency component of phase L3 (C) current    |
| $U_1RMS$    | Fundamental frequency component of voltage channel $U_1/V$ |
| $U_2RMS$    | Fundamental frequency component of voltage channel $U_2/V$ |
| $U_3RMS$    | Fundamental frequency component of voltage channel $U_3/V$ |
| $U_4RMS$    | Fundamental frequency component of voltage channel $U_4/V$ |

#### General settings

The following general settings define the general behavior of the function. These settings are static i.e. it is not possible to change them by editing the setting group.

Table. 4.4.21 - 189. General settings of the function.

| Name                         | Range   | Default | Description   |
|------------------------------|---|---------|---|
| Pole slip [78]<br>LN mode    | <ul style="list-style-type: none"> <li>• On</li> <li>• Blocked</li> <li>• Test</li> <li>• Test/<br/>Blocked</li> <li>• Off</li> </ul> | On      | Set mode of OOS block.<br>This parameter is visible only when <i>Allow setting of individual LN mode</i> is enabled in <i>General</i> menu. |
| Pole slip force<br>status to | <ul style="list-style-type: none"> <li>• Normal</li> <li>• Start</li> <li>• Trip</li> <li>• Blocked</li> </ul>                        | Normal  | Force the status of the function. Visible only when <i>Enable stage forcing</i> parameter is enabled in <i>General</i> menu.                |

### Pick-up settings

Parameters listed below determine the slip detection area. Slip detection area consists of detection circle and two side blinders. For a slip to be counted the impedance must first enter the circle, then while inside the circle the impedance must cross the blinders and then exit the circle. Keep in mind that the impedance must stay between the blinders longer than what is set to *Minimum locus traverse time between blinders* for the function to count the slip. If more than one slips are required for the function to trip the measured impedance must enter the circle from the same side each cycle. If time set to *Reset slip detection after last detected slip* has passed between slips the slip counter is reset.

Setting group selection controls the operating characteristics of the function, i.e. the user or user-defined logic can change function parameters while the function is running.

Table. 4.4.21 - 190. Pick-up settings.

| Name   | Range                         | Step        | Default       | Description  |
|--|-------------------------------|-------------|---------------|--|
| X detection circle<br>offset from origin (pri)     | -50 000.00...50<br>000.00 Ohm | 0.01<br>Ohm | -50.00<br>Ohm | Moves the midpoint of circle in the X-axis (reactance).  |
| R detection circle<br>offset from origo (pri)      | -50 000.00...50<br>000.00 Ohm | 0.01<br>Ohm | 0.00<br>Ohm   | Moves the midpoint of circle in the R-axis (resistance).   |
| Detection circle r (pri)                           | 0.01...50 000.00<br>Ohm       | 0.01<br>Ohm | 50.00<br>Ohm  | Sets the radius of the detection circle.   |
| R+ side blinder<br>location (pri)                  | 0.00...50 000.00<br>Ohm       | 0.01<br>Ohm | 20.00<br>Ohm  | R+ side blinder. Impedance must cross this level after entering the circle for the function to count a slip. |
| R- side blinder<br>location (pri)                  | -50<br>000.00...0.00<br>Ohm   | 0.01<br>Ohm | -20.00<br>Ohm | R- side blinder. Impedance must cross this level after entering the circle for the function to count a slip. |
| Minimum locus<br>traverse time between<br>blinders | 0.000...1800.00<br>s          | 0.005<br>s  | 0.050<br>s    | Minimum time impedance must stay between the blinders so that the function will count a slip.                |
| Pole slip detection<br>limit to trip               | 1...5 slips                   | 1<br>slips  | 1 slips       | How many slips need to be detected for the function to trip.   |
| Reset slip detection<br>after last detected slip   | 0.000...1800.000<br>s         | 0.005<br>s  | 1.000<br>s    | Maximum time between slips before the function resets the slip counter to zero.                              |

Figure. 4.4.21 - 110. Impedance must enter the circle first then cross the blinders and lastly exit the circle for the function to count a slip. Impedance can enter the circle from either side but it must keep entering the circle from the same side for the function to keep counting the slips.

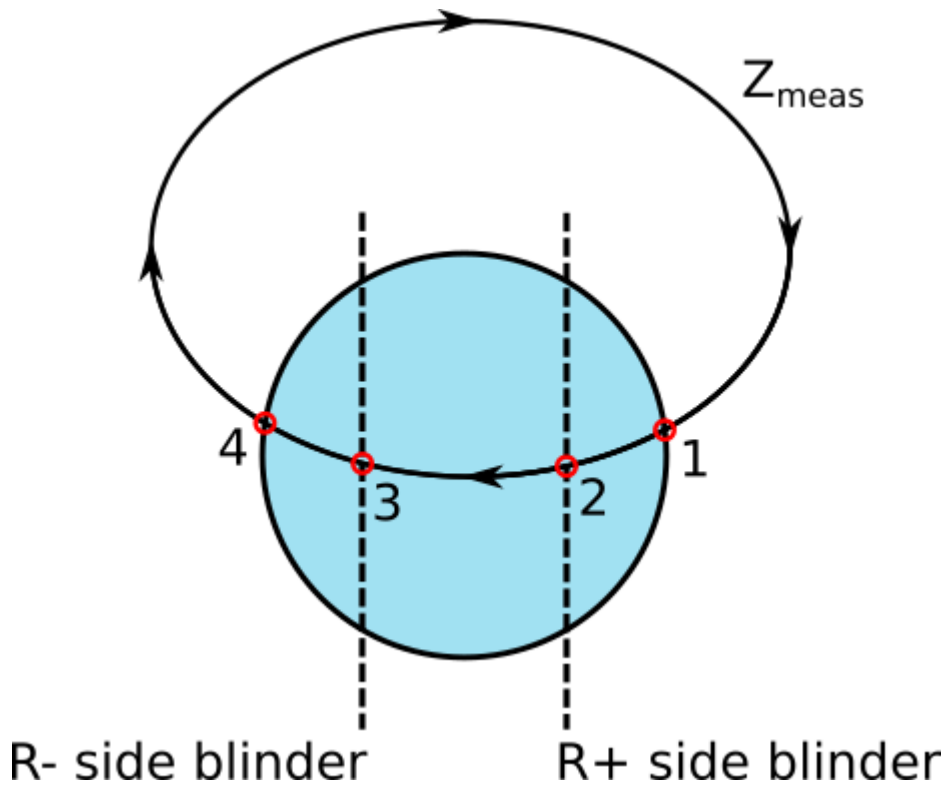

**Read-only parameters**

The function's *Info* page displays useful, real-time information on the state of the protection function. It is accessed either through the device's HMI display, or through the setting tool software when it is connected to the device and its Live Edit mode is active.

Table. 4.4.21 - 191. Information displayed by the function.

| Name                        | Range  | Description  |
|-----------------------------|--|--|
| Pole slip [78] LN behaviour | <ul style="list-style-type: none"> <li>• On</li> <li>• Blocked</li> <li>• Test</li> <li>• Test/Blocked</li> <li>• Off</li> </ul> | Displays the mode of OOS block.<br>This parameter is visible only when <i>Allow setting of individual LN mode</i> is enabled in <i>General</i> menu. |
| Pole slip condition         | <ul style="list-style-type: none"> <li>• Normal</li> <li>• Start</li> <li>• Trip</li> <li>• Blocked</li> </ul>                   | Displays status of the protection function.  |
| Configuration status        | <ul style="list-style-type: none"> <li>• Ok</li> <li>• Incorrect VT set</li> <li>• Incorrect char. Set</li> </ul>                | Displays the status of settings currently in use.  |

## Function blocking

The blocking signal is evaluated at the start of each program cycle. The blocking signals are connected to the function's dedicated input, which can be configured in the *IO → Blocking Input Control* tab of the function.

- When the pick-up element activates and the blocking signal is not active, a START signal is generated, and the function starts or continues with the trip time countdown.
- When the pick-up element activates and the blocking signal is active, a BLOCKED signal is generated, and the function does not process the event further.
- When a START signal is already active and the blocking input signal becomes active, the START signal is reset and BLOCKED signal is generated. The release time characteristics are then processed in the same way as when the pick-up signal is reset.

The blocking signal needs to reach the device minimum of 5 ms before the set operating delay has passed in order for the blocking to activate in time.

## Events and registers

The pole slip protection function (abbreviated "OOS" in event block names) generates events and registers from the status changes in the events listed below. The user can select which event messages are stored in the main event buffer: ON, OFF, or both. The events triggered by the function are recorded with a time stamp.

The function's outputs can be used for direct I/O controlling and user logic programming. The function also provides a resettable cumulative counter for the START, TRIP and BLOCKED events.

Table. 4.4.21 - 192. Event messages.

| Event block name | Event names                       |
|------------------|-----------------------------------|
| OOS1             | Poleslip Detection START ON/OFF   |
| OOS1             | Poleslip Trip ON/OFF              |
| OOS1             | Poleslip Detection BLOCKED ON/OFF |

The function registers its operation into the last twelve (12) time-stamped registers. The register of the function records the ON event process data for START, TRIP or BLOCKED. The table below presents the structure of the function's register content.

Table. 4.4.21 - 193. Register content.

| Register             | Description                                       |
|----------------------|---|
| Date and time        | dd.mm.yyyy hh:mm:ss.mss                           |
| Event                | Event name  |
| In blinder time      | Duration of reactance being between the blinders. |
| Setting group in use | Setting group 1...8 active                        |

## 4.4.22 Transformer thermal overload protection (TT>; 49T)

The transformer thermal overload protection function is used for monitoring and protecting thermal capacity in power transformers.

The function constantly monitors the instant values of phase TRMS currents (including harmonics up to 31<sup>st</sup>) and calculates the set thermal replica status in 5 ms cycles. The function includes a total memory function of the load current conditions according to IEC 60255-8.

The function is based on a thermal replica which represents the protected object's or cable's thermal loading in relation to the current going through the object. The thermal replica includes the calculated thermal capacity that the "memory" uses; it is an integral function which tells this function apart from a normal overcurrent function and its operating principle for overload protection applications.

The thermal image for the function is calculated according to the equation described below:

$$\theta_{t\%} = \left( \left( \theta_{t-1} - \left( \frac{I_{MAX}}{I_N \times k_{SF} \times k_{AMB}} \right)^2 \times e^{-\frac{t}{\tau_1/\tau_2}} \right) + \left( \frac{I_{MAX}}{I_N \times k_{SF} \times k_{AMB}} \right)^2 \right) \times 100\%$$

Where:

- $\theta_{t\%}$  = Thermal image status, percentage of the maximum available thermal capacity
- $\theta_{t-1}$  = Thermal image status, previous calculation cycle (the memory of the function)
- $I_{max}$  = Measured maximum of the three TRMS phase currents
- $I_N$  = Current for the 100 % thermal capacity to be used (pick-up current in p.u.,  $t_{max}$  achieved in  $\tau \times 5$ )
- $k_{SF}$  = Loading factor (service factor), maximum allowed load current (in p.u.) value, dependent on the protected object or cable/line installation
- $k_{amb}$  = Temperature correction factor, either from a linear approximation or from a settable ten-point thermal capacity curve
- $t$  = Calculation time step (0.005 s)
- $e$  = Euler's number
- $\tau_1$  = Thermal heating time constant of the protected object (in minutes)
- $\tau_2$  = Thermal heating time constant of the protected object (in minutes)

The basic operating principle of the thermal replica is based on the nominal temperature rise, which is achieved when the protected object is loaded with a nominal load in a nominal ambient temperature. When the object is loaded with a nominal load for a time equal to its heating constant tau ( $\tau$ ), 63% of the nominal thermal capacity is used. When the loading continues until five times this given constant, the used thermal capacity approaches 100 % indefinitely but never exceeds it. With a single time constant model the cooling of the object follows this same behavior, the reverse of the heating when the current feeding is zero.

Figure. 4.4.22 - 111. Example of thermal image calculation with nominal conditions.

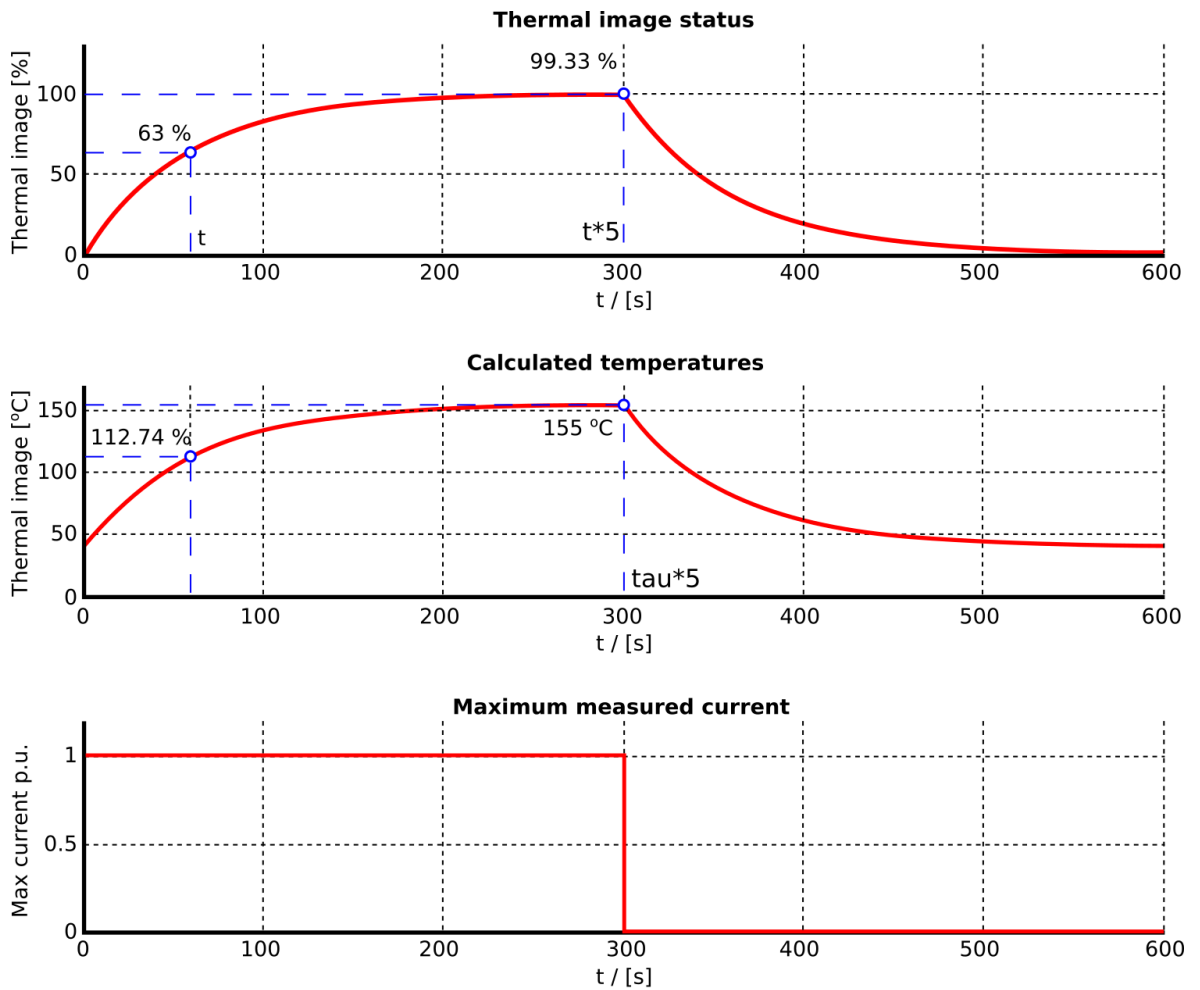

**Settings**

|                       |                                |
|-----------------------|--------------------------------|
| $I_N = 1.00$ p.u.     | Max. temperature rise = 115 °C |
| $Q_{t-1} = 0.01$ %    | Ambient temperature = 40 °C    |
| $\tau = 1$ minutet    | Max end temperature = 155 °C   |
| Service factor = 1.00 | Temperature k factor = 1.00    |

The described behavior is based on the assumption that the monitored object (whether a cable, a line or an electrical device) has a homogenous body which generates and dissipates heat with a rate proportional to the temperature rise caused by the current squared. This is usually the case with cables and other objects while the heat dissipation of overhead lines is dependent on the weather conditions. Weather conditions considering the prevailing conditions in the thermal replica are compensated with the ambient temperature coefficient which is constantly calculated and changing when using RTD sensor for the measurement. When the ambient temperature of the protected object is stable it can be set manually (e.g. underground cables).

The ambient temperature compensation takes into account the set minimum and maximum temperatures and the load capacity of the protected object as well as the measured or set ambient temperature. The calculated coefficient is a linear correction factor, as the following formula shows:

$$t_{Amb < t_{min}} = k_{min}$$

$$t_{Amb < t_{ref}} = \left( \frac{1 - k_{min}}{t_{ref} - t_{min}} \times (t_{AMB} - t_{min}) \right) + k_{min}$$

$$t_{Amb > t_{ref}} = \left( \frac{k_{max} - 1}{t_{max} - t_{ref}} \times (t_{AMB} - t_{ref}) \right) + 1.0$$

$$t_{Amb > t_{max}} = k_{max}$$

Where:

- $t_{amb}$  = Measured (set) ambient temperature (can be set in °C or °F)
- $t_{max}$  = Maximum temperature (can be set in °C or °F) for the protected object
- $k_{max}$  = Ambient temperature correction factor for the maximum temperature
- $t_{min}$  = Minimum temperature (can be set in °C or °F) for the protected object
- $k_{min}$  = Ambient temperature correction factor for the minimum temperature
- $t_{ref}$  = Ambient temperature reference (can be set in °C or °F, the temperature in which the manufacturer's temperature presumptions apply, the temperature correction factor is 1.0)

Figure. 4.4.22 - 112. Ambient temperature coefficient calculation (a three-point linear approximation and a settable correction curve).

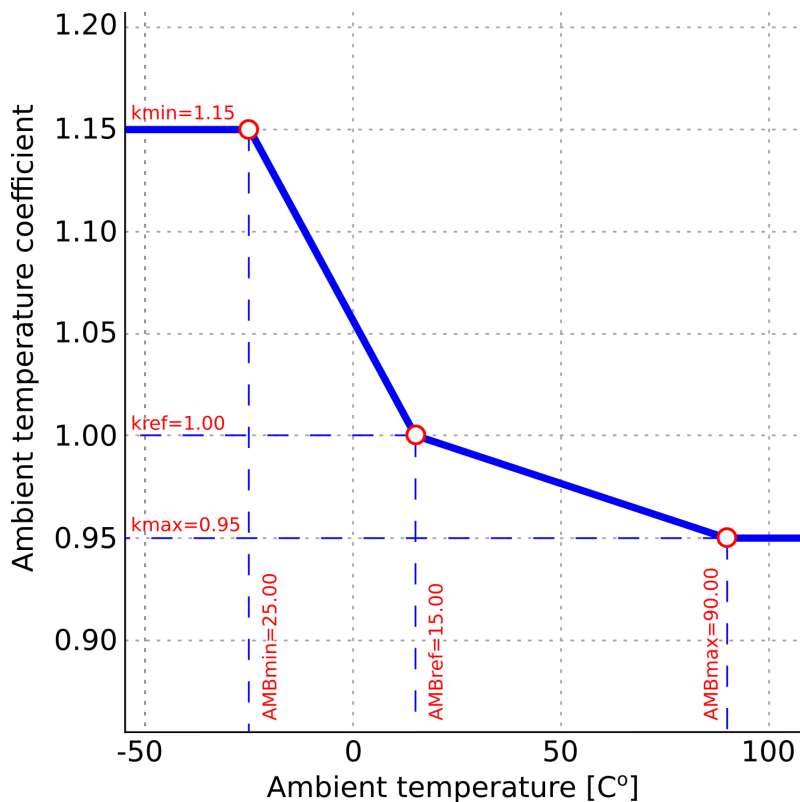

### Function inputs and outputs

The following figure presents a simplified function block diagram of the transformer thermal overload protection function.

Figure. 4.4.22 - 113. Simplified function block diagram of the TT> function.

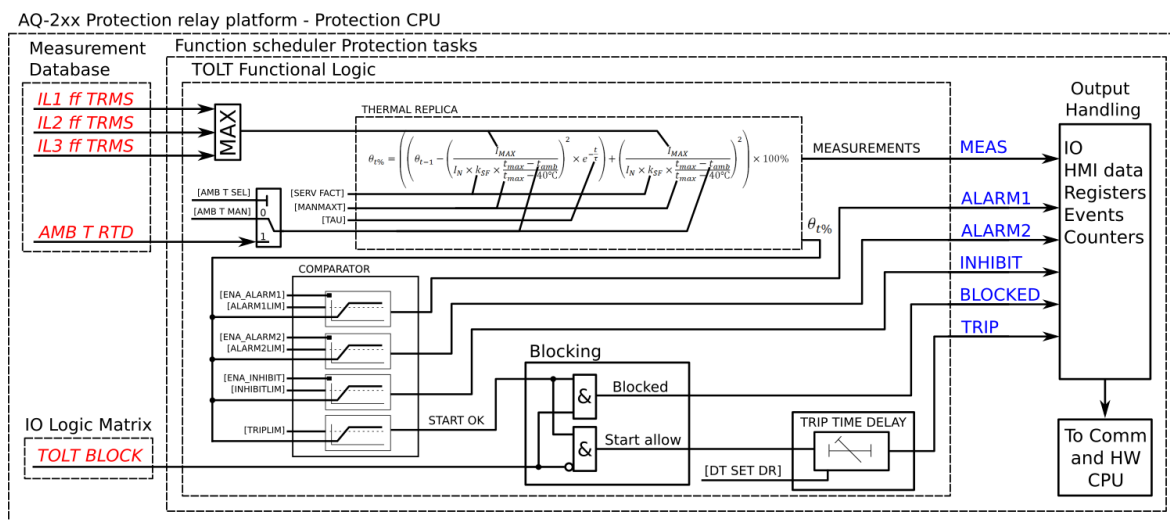

### Measured input

The function block uses phase current measurement values. The function block uses TRMS values from the whole harmonic spectrum of 32 components. RTD input can be used for measuring the ambient temperature.

Table. 4.4.22 - 194. Measurement inputs of the TT> function.

| Signal        | Description  |
|---------------|--|
| $I_{L1}$ TRMS | TRMS measurement of phase L1 (A) current           |
| $I_{L2}$ TRMS | TRMS measurement of phase L2 (B) current           |
| $I_{L3}$ TRMS | TRMS measurement of phase L3 (C) current           |
| RTD           | Temperature measurement for the ambient correction |

Table. 4.4.22 - 195. General settings (not selectable under setting groups)

| Name        | Range  | Default  | Description   |
|-------------|--|----------|---|
| TT> LN mode | <ul style="list-style-type: none"> <li>On</li> <li>Blocked</li> <li>Test</li> <li>Test/Blocked</li> <li>Off</li> </ul> | On       | Set mode of TOLT block. This parameter is visible only when <i>Allow setting of individual LN mode</i> is enabled in <i>General</i> menu. |
| TT> mode    | <ul style="list-style-type: none"> <li>Disabled</li> <li>Activated</li> </ul>  | Disabled | The selection of the function is activated or disabled in the configuration. By default it is not in use.                                 |

| Name                | Range  | Default | Description  |
|---------------------|--|---------|--|
| TT> force status to | <ul style="list-style-type: none"> <li>• Normal</li> <li>• Blocked</li> <li>• Alarm1 On</li> <li>• Alarm2 On</li> <li>• Inhibit On</li> <li>• Trip On</li> </ul> | Normal  | Force the status of the function. Visible only when <i>Enable stage forcing</i> parameter is enabled in <i>General</i> menu.     |
| Temp C or F deg     | <ul style="list-style-type: none"> <li>• C</li> <li>• F</li> </ul>   | C       | The selection of whether the temperature values of the thermal image and RTD compensation are shown in Celsius or in Fahrenheit. |

Table. 4.4.22 - 196. Settings for thermal replica.

| Name                     | Range                       | Step                | Default             | Description  |
|--------------------------|-----------------------------|---------------------|---------------------|--|
| IN thermal cap current   | 0.10...40.00xI <sub>n</sub> | 0.01xI <sub>n</sub> | 1.00xI <sub>n</sub> | The current for the 100 % thermal capacity to be used (the pick-up current in p.u., with t <sub>max</sub> achieved in time τ x 5).   |
| tau h (t const)          | 0.1...500.0min              | 0.1min              | 10.0min             | The τ <sub>h</sub> time constant setting. This time constant is used for the heating of the protected object.  |
| tau c (t const)          | 0.1...500.0min              | 0.1min              | 10.0min             | The τ <sub>c</sub> time constant setting. This time constant is used for the cooling of the protected object.  |
| ksF (service factor)     | 0.01...5.00                 | 0.01                | 1.00                | The service factor which corrects the value of the maximum allowed current according to installation and other conditions varying from the presumptive conditions.   |
| Cold reset default theta | 0.0...150.0%                | 0.1%                | 60.0%               | The thermal image status in the restart of the function or the device. The value is given in percentages of the used thermal capacity of the protected object. It is also possible to reset the thermal element.<br>This parameter can be used when testing the function to manually set the current thermal cap to any value. |

Table. 4.4.22 - 197. Environmental settings

| Name  | Range   | Step | Default    | Description   |
|---|---|------|------------|---|
| Object max. temp. (t <sub>max</sub> = 100%) | 0...500deg  | 1deg | 90deg      | The maximum allowed temperature for the protected object. The default suits for Celsius range and for PEX-insulated cables.   |
| Ambient temp. sel.                          | <ul style="list-style-type: none"> <li>• Manual set</li> <li>• RTD</li> </ul> | -    | Manual set | The selection of whether fixed or measured ambient temperature is used for the thermal image biasing.   |
| Man. amb. temp. set                         | 0...500deg  | 1deg | 15deg      | The manual fixed ambient temperature setting for the thermal image biasing. Underground cables usually use 15 °C. This setting is visible if "Manual set" is selected for the "Ambient temp. sel." setting. |

| Name   | Range  | Step                | Default             | Description  |
|--|--|---------------------|---------------------|--|
| RTD amb. temp. read.   | 0...500deg   | 1deg                | 15deg               | The RTD ambient temperature reading for the thermal image biasing. This setting is visible if "RTD" is selected for the "Ambient temp. sel." setting.  |
| Ambient lin. or curve  | <ul style="list-style-type: none"> <li>Linear est.</li> <li>Set curve</li> </ul> | -                   | Linear est.         | The selection of how to correct the ambient temperature, either by internally calculated compensation based on end temperatures or by a user-settable curve. The default setting is "Linear est." which means the internally calculated correction for ambient temperature.  |
| Temp. reference (t <sub>ref</sub> )<br>k <sub>amb</sub> =1.0 | -60...500deg   | 1deg                | 15deg               | The temperature reference setting. The manufacturer's temperature presumptions apply and the thermal correction factor is 1.00 (rated temperature). For underground cables the set value for this is usually 15 °C and for cables in the air it is usually 25 °C.<br>This setting is visible if "Ambient lin. or curve" is set to "Linear est."  |
| Max. ambient temp.   | 0...500deg   | 1deg                | 45deg               | The maximum ambient temperature setting. If the measured temperature is more than the maximum set temperature, the set correction factor for the maximum temperature is used. This setting is visible if "Ambient lin. or curve" is set to "Linear est."   |
| k at max. amb. temp.   | 0.01...5.00xI <sub>n</sub>   | 0.01xI <sub>n</sub> | 1.00xI <sub>n</sub> | The temperature correction factor for the maximum ambient temperature setting. This setting is visible if "Ambient lin. or curve" is set to "Linear est."  |
| Min. ambient temp.   | -60...500deg   | 1deg                | 0deg                | The minimum ambient temperature setting. If the measured temperature is below the minimum set temperature, the set correction factor for minimum temperature is used. This setting is visible if "Ambient lin. or curve" is set to "Linear est."   |
| k at min. amb. temp.   | 0.01...5.00xI <sub>n</sub>   | 0.01xI <sub>n</sub> | 1.00xI <sub>n</sub> | The temperature correction factor for the minimum ambient temperature setting. This setting is visible if "Ambient lin. or curve" is set to "Linear est."  |
| Amb. temp. ref. 1...10                                       | -50.0...500.0deg   | 0.1deg              | 15deg               | The temperature reference points for the user-settable ambient temperature coefficient curve. This setting is visible if "Ambient lin. or curve" is set to "Set curve".  |
| Amb. temp. k1...k10  | 0.01...5.00  | 1.00                | 0.01                | The coefficient value for the temperature reference point. The coefficient and temperature reference points must be set as pairs. This setting is visible if "Ambient lin. or curve" is set to "Set curve".  |
| Add curvepoint 3...10  | <ul style="list-style-type: none"> <li>Not used</li> <li>Used</li> </ul>         | -                   | Not used            | The selection of whether or not the curve temperature/coefficient pair is in use. The minimum number to be set for the temperature/coefficient curve is two pairs and the maximum is ten pairs. If the measured temperature is below the set minimum temperature reference or above the maximum set temperature reference, the used temperature coefficient is the first or last value in the set curve. This setting is visible if "Ambient lin. or curve" is set to "Set curve". |

## Pick-up settings

The operating characteristics of the machine thermal overload protection function are completely controlled by the thermal image. The thermal capacity value calculated from the thermal image can set the I/O controls with ALARM 1, ALARM 2, INHIBIT and TRIP signals.

Setting group selection controls the operating characteristics of the function, i.e. the user or user-defined logic can change function parameters while the function is running.

Table. 4.4.22 - 198. Pick-up settings.

| Name                             | Range   | Step   | Default  | Description  |
|----------------------------------|---|--------|----------|--|
| Enable<br>TT><br>Alarm<br>1      | <ul style="list-style-type: none"> <li>Disabled</li> <li>Enabled</li> </ul> | -      | Disabled | Enabling/disabling the ALARM 1 signal and the I/O.   |
| TT><br>Alarm<br>1 level          | 0.0...150.0%  | 0.1%   | 40%      | ALARM 1 activation threshold.  |
| Enable<br>TT><br>Alarm<br>2      | <ul style="list-style-type: none"> <li>Disabled</li> <li>Enabled</li> </ul> | -      | Disabled | Enabling/disabling the ALARM 2 signal and the I/O.   |
| TT><br>Alarm<br>2 level          | 0.0...150.0%  | 0.1%   | 40%      | ALARM 2 activation threshold.  |
| Enable<br>TT><br>Rest<br>Inhibit | <ul style="list-style-type: none"> <li>Disabled</li> <li>Enabled</li> </ul> | -      | Disabled | Enabling/disabling the INHIBIT signal and the I/O.   |
| TT><br>Inhibit<br>level          | 0.0...150.0%  | 0.1%   | 80%      | INHIBIT activation threshold.  |
| Enable<br>TT><br>Trip            | <ul style="list-style-type: none"> <li>Disabled</li> <li>Enabled</li> </ul> | -      | Enabled  | Enabling/disabling the TRIP signal and the I/O.  |
| TT><br>Trip<br>level             | 0.0...150.0%  | 0.1%   | 100%     | TRIP activation threshold.<br>This parameter is only visible when "Enable TT> Trip" is Enabled.  |
| TT><br>Trip<br>delay             | 0.000...3600.000s   | 0.005s | 0.000s   | The trip signal's additional delay. This delay delays the trip signal generation by a set time. The default setting is 0.000 s which does not give an added time delay for the trip signal.<br>This parameter is only visible when "Enable TT> Trip" is Enabled. |

## Function blocking

The blocking signal is evaluated at the start of each program cycle. The blocking signals are connected to the function's dedicated input, which can be configured in the *IO* → *Blocking Input Control* tab of the function.

- When the pick-up element activates and the blocking signal is not active, a START signal is generated, and the function starts or continues with the trip time countdown.
- When the pick-up element activates and the blocking signal is active, a BLOCKED signal is generated, and the function does not process the event further.
- When a START signal is already active and the blocking input signal becomes active, the START signal is reset and BLOCKED signal is generated. The release time characteristics are then processed in the same way as when the pick-up signal is reset.

The blocking signal needs to reach the device minimum of 5 ms before the set operating delay has passed in order for the blocking to activate in time.

## Measurements and indications

The function outputs measured process data from the following magnitudes:

Table. 4.4.22 - 199. General status codes.

| Name              | Range  | Description   |
|-------------------|--|---|
| TT> LN behaviour  | <ul style="list-style-type: none"> <li>• On</li> <li>• Blocked</li> <li>• Test</li> <li>• Test/Blocked</li> <li>• Off</li> </ul>                                   | <p>Set mode of TOLT block.</p> <p>This parameter is visible only when <i>Allow setting of individual LN mode</i> is enabled in <i>General</i> menu.</p>   |
| TT> Condition     | <ul style="list-style-type: none"> <li>• Normal</li> <li>• Alarm 1 ON</li> <li>• Alarm 2 ON</li> <li>• Inhibit ON</li> <li>• Trip ON</li> <li>• Blocked</li> </ul> | <p>The function's operating condition at the moment considering binary IO signal status. No outputs are controlled when the status is "Normal".</p>   |
| Thermal status    | <ul style="list-style-type: none"> <li>• Light/No load</li> <li>• High overload</li> <li>• Overloading</li> <li>• Load normal</li> </ul>                           | <p>The function's thermal image status. When the measured current is below 1 % of the nominal current, the status "Light/No load" is shown. When the measured current is below the trip limit, the status "Load normal" is shown. When the measured current is above the pick-up limit but below <math>2 \times I_n</math>, the status "Overloading" is shown. When the measured current is above <math>2 \times I_n</math>, the status "High overload" is shown.</p> |
| TT> Setting alarm | <ul style="list-style-type: none"> <li>• SF setting ok</li> <li>• Service factor set fault. Override to 1.0</li> </ul>   | <p>Indicates if SF setting has been set wrong and the actually used setting is 1.0. Visible only when there is a setting fault.</p>   |
| TT> Setting alarm | <ul style="list-style-type: none"> <li>• Ambient setting ok</li> <li>• Ambient t set fault. Override to 1.0</li> </ul>   | <p>Indicates if ambient temperature settings have been set wrong and actually used setting is 1.0. Visible only when there is a setting fault.</p>  |

| Name                 | Range   | Description   |
|----------------------|---|---|
| TT><br>Setting alarm | <ul style="list-style-type: none"> <li>Nominal current calc ok</li> <li>Nominal current set fault. Override to 1.0</li> </ul> | Indicates if nominal current calculation is set wrong and actually used setting is 1.0. Visible only when there is a setting fault. |
| TT><br>Setting alarm | <ul style="list-style-type: none"> <li>Ambient setting ok</li> <li>Inconsistent setting of ambient k</li> </ul>               | Indicates if ambient k setting has been set wrong. Visible only when there is a setting fault.                                      |

Table. 4.4.22 - 200. Measurements.

| Name          | Range  | Description/values  |
|---------------|--|---|
| Currents      | <ul style="list-style-type: none"> <li>Primary A</li> <li>Secondary A</li> <li>Per unit</li> </ul> | The active phase current measurement from IL1 (A), IL2 (B) and IL3 (C) phases in given scalings.  |
| Thermal image | Thermal image calc.  | <ul style="list-style-type: none"> <li>- TT&gt; Trip expect mode: No trip expected/Trip expected</li> <li>- TT&gt; Time to 100 % theta: Time to reach the 100 % thermal cap</li> <li>- TT&gt; Rreference T curr.: reference/pick-up value (IEQ)</li> <li>- TT&gt; Active meas. curr.: the measured maximum TRMS current at a given moment</li> <li>- TT&gt; T est. with act. curr.: estimation of the used thermal capacity including the current at a given moment</li> <li>- TT&gt; T at a given moment: the thermal capacity used at that moment</li> </ul>                              |
|               | Temp. estimates  | <ul style="list-style-type: none"> <li>- TT&gt; Used k for amb. temp: the ambient correction factor at a given moment</li> <li>- TT&gt; Max. temp. rise all.: the maximum allowed temperature rise</li> <li>- TT&gt; Temp. rise atm: the calculated temperature rise at a given moment</li> <li>- TT&gt; Hot spot estimate: the estimated hot spot temperature including the ambient temperature</li> <li>- TT&gt; Hot spot max. all.: the maximum allowed temperature for the object</li> </ul>  |
|               | Timing status  | <ul style="list-style-type: none"> <li>- TT&gt; Trip delay remaining: the time to reach 100% theta</li> <li>- TT&gt; Trip time to rel.: the time to reach theta while staying below the trip limit during cooling</li> <li>- TT&gt; Alarm 1 time to rel.: the time to reach theta while staying below the Alarm 1 limit during cooling</li> <li>- TT&gt; Alarm 2 time to rel.: the time to reach theta while staying below the Alarm 2 limit during cooling</li> <li>- TT&gt; Inhibit time to rel.: the time to reach theta while staying below the Inhibit limit during cooling</li> </ul> |

Table. 4.4.22 - 201. Counters.

| Name         | Description / values  |
|--------------|---|
| Alarm1 inits | The number of times the function has activated the Alarm 1 output |
| Alarm2 inits | The number of times the function has activated the Alarm 2 output |

| Name             | Description / values  |
|------------------|---|
| Restart inhibits | The number of times the function has activated the Restart inhibit output |
| Trips            | The number of times the function has tripped                              |
| Trips Blocked    | The number of times the function trips has been blocked                   |

## Events and registers

The line thermal overload protection function (abbreviated "TOLT" in event block names) generates events and registers from the status changes in the events listed below. The user can select which event messages are stored in the main event buffer: ON, OFF, or both. The events triggered by the function are recorded with a time stamp.

The function's outputs can be used for direct I/O controlling and user logic programming. The function also provides a resettable cumulative counter for the ALARM, INHIBIT, TRIP and BLOCKED events.

Table. 4.4.22 - 202. Event messages.

| Event block name | Event names    |
|------------------|----------------|
| TOLT1            | Alarm1 ON/OFF  |
| TOLT1            | Alarm2 ON/OFF  |
| TOLT1            | Inhibit ON/OFF |
| TOLT1            | Trip ON/OFF    |
| TOLT1            | Block ON/OFF   |

The function registers its operation into the last twelve (12) time-stamped registers. The register of the function records the ON event process data for TRIP, BLOCKED, etc. signals. The table below presents the structure of the function's register content.

Table. 4.4.22 - 203. Register content.

| Name                         | Description             |
|------------------------------|-------------------------|
| Date and time                | dd.mm.yyyy hh:mm:ss.mss |
| Event                        | Event name              |
| Time to reach 100 % theta    | seconds                 |
| Ref. T current               | $x I_n$                 |
| Active meas. current         | $x I_n$                 |
| T at a given moment          | %                       |
| Max. temp. rise allowed      | degrees                 |
| Temp. rise at a given moment | degrees                 |
| Hot spot estimate            | degrees                 |

| Name                     | Description                |
|--------------------------|----------------------------|
| Hot spot maximum allowed | degrees                    |
| Trip delay rem.          | seconds                    |
| Setting group in use     | Setting group 1...8 active |

### 4.4.23 Resistance temperature detectors (RTD)

Resistance temperature detectors (or RTDs) can be used to measure both temperatures of motors/ generators and ambient temperatures. Typically an RTD is a thermocouple or of type PT100. Up to three (3) separate RTD modules based on an external Modbus are supported; each can hold up to eight (8) measurement elements. Up to two (2) separate RTD option cards are supported by this function. Sixteen (16) individual element monitors can be set for this alarm function, and each of those can be set to alarm two (2) separate alarms from one selected input. The user can set alarms and measurements to be either in degrees Celsius or Fahrenheit.

Figure. 4.4.23 - 114. Simplified function block diagram of the resistance temperature detection function.

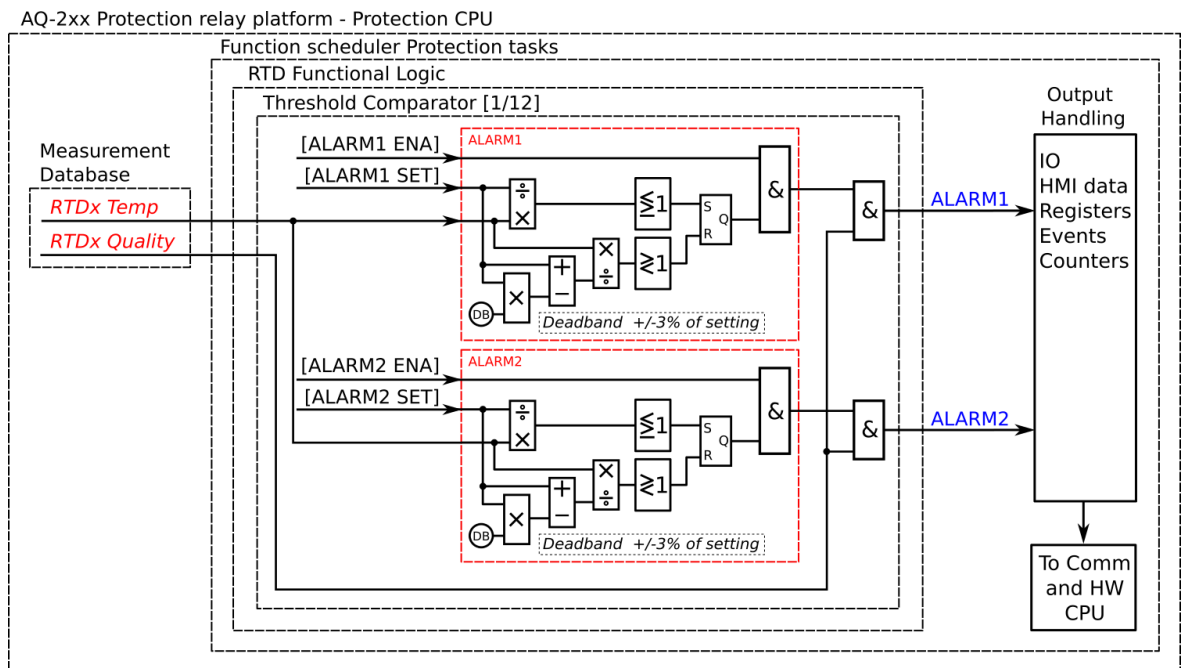

### Settings

Table. 4.4.23 - 204. General settings of the function.

| Name        | Range  | Default | Description  |
|-------------|--|---------|--|
| RTD LN mode | <ul style="list-style-type: none"> <li>On</li> <li>Blocked</li> <li>Test</li> <li>Test/Blocked</li> <li>Off</li> </ul> | On      | Set mode of RTD block. This parameter is visible only when <i>Allow setting of individual LN mode</i> is enabled in <i>General</i> menu. |

| Name             | Range  | Default | Description   |
|------------------|--|---------|---|
| RTD LN behaviour | <ul style="list-style-type: none"> <li>On</li> <li>Blocked</li> <li>Test</li> <li>Test/Blocked</li> <li>Off</li> </ul> | -       | <p>Displays the mode of RTD block.</p> <p>This parameter is visible only when <i>Allow setting of individual LN mode</i> is enabled in <i>General</i> menu.</p> |

Setting up an RTD measurement, the user first needs to set the measurement module to scan the wanted RTD elements. A multitude of Modbus-based modules are supported. Communication requires bitrate, databits, parity, stopbits and Modbus I/O protocol to be set; this is done at *Communication* → *Connections*. Once communication is set, the wanted channels are selected at *Communication* → *Protocols* → *ModbusIO*. Then the user selects the measurement module from the three (3) available modules (A, B and C), as well as the poll address. Additionally, both the module type and the polled channels need to be set. When using a thermocouple module, the thermo element type also needs to be set for each of the measurement channels. Once these settings are done the RTDs are ready for other functions.

Table. 4.4.23 - 205. Function settings for Channel x (Sx).

| Name                    | Range  | Step | Default      | Description   |
|-------------------------|--|------|--------------|---|
| S1...S16 enable         | No<br>Yes  | -    | No           | Enables/disables the selection of sensor measurements and alarms.   |
| S1...S16 module         | <ul style="list-style-type: none"> <li>InternalRTD1</li> <li>InternalRTD2</li> <li>ExtModuleA</li> <li>ExtModuleB</li> <li>ExtModuleC</li> </ul>   | -    | InternalRTD1 | Selects the measurement module. Internal RTD modules are option cards installed to the device. External modules are Modbus based external devices.          |
| S1...S16 channel        | <ul style="list-style-type: none"> <li>Channel 0</li> <li>Channel 1</li> <li>Channel 2</li> <li>Channel 3</li> <li>Channel 4</li> <li>Channel 5</li> <li>Channel 6</li> <li>Channel 7</li> </ul> | -    | Channel 0    | Selects the measurement channel in the selected module.   |
| S1...S16 Deg C/Dec F    | <ul style="list-style-type: none"> <li>Deg C</li> <li>Deg F</li> </ul>   | -    | Deg C        | Selects the measurement temperature scale (Celsius or Fahrenheit).  |
| S1...S16 Measurement    | -  | -    | -            | Displays the measurement value in the selected temperature scale.   |
| S1...S16 Sensor         | <ul style="list-style-type: none"> <li>Ok</li> <li>Invalid</li> </ul>  | -    | -            | Displays the measured sensor's data validity. If the sensor reading has any problems, the sensor data is set to "Invalid" and the alarms are not activated. |
| S1...S16 Enable alarm 1 | <ul style="list-style-type: none"> <li>Disable</li> <li>Enable</li> </ul>  | -    | Disable      | Enables/disables the selection of Alarm 1 for the measurement channel x.  |
| S1...S16 Alarm1 >/<     | <ul style="list-style-type: none"> <li>&gt;</li> <li>&lt;</li> </ul>   | -    | >            | Selects whether the alarm activates when measurement is above or below the pick-up setting value.   |

| Name                          | Range   | Step   | Default | Description  |
|-------------------------------|---|--------|---------|--|
| S1...S16<br>Alarm1            | -101.0...2000.0deg  | 0.1deg | 0.0deg  | Sets the pick-up value for Alarm 1. The alarm is activated if the measurement goes above or below this setting mode (depends on the selected mode in "Sx Alarm1 >/<"). |
| S1...S16<br>sensor            | <ul style="list-style-type: none"> <li>• Ok</li> <li>• Invalid</li> </ul>     | -      | -       | Displays the measured sensor's data validity. If the sensor reading has any problems, the sensor data is set to "Invalid" and the alarms are not activated.            |
| S1...S16<br>Enable alarm<br>2 | <ul style="list-style-type: none"> <li>• Disable</li> <li>• Enable</li> </ul> | -      | Disable | Enables/disables the selection of Alarm 2 for the measurement channel x.   |
| S1...S16<br>Alarm2 >/<        | <ul style="list-style-type: none"> <li>• &gt;</li> <li>• &lt;</li> </ul>      | -      | >       | Selects whether the measurement is above or below the setting value.   |
| S1...S16<br>Alarm2            | -101.0...2000.0deg  | 0.1deg | 0.0deg  | Sets the value for Alarm 2. The alarm is activated if the measurement goes above or below this setting mode (depends on the selected mode in "Sx Alarm2 >/<").         |

Function can be set to monitor the measurement data from previously set RTD channels. A single channel can be set to have several alarms if the user sets the channel to multiple sensor inputs. In each sensor setting the user can select the monitored module and channel, as well as the monitoring and alarm setting units (°C or °F). The alarms can be enabled, given a setting value (in degrees), and be set to trigger either above or below the setting value. There are sixteen (16) available sensor inputs in the function. An active alarm requires a valid channel measurement. It can be invalid if communication is not working or if a sensor is broken.

When the RTDs have been set, the values can be read to SCADA (or some other control system). The alarms can also be used for direct output control as well as in logics.

## Events

The resistance temperature detector function (abbreviated "RTD" in event block names) generates events and registers from the status changes in the events listed below. The user can select which event messages are stored in the main event buffer: ON, OFF, or both. The events triggered by the function are recorded with a time stamp.

The function's outputs can be used for direct I/O controlling and user logic programming. The function also provides a resettable cumulative counter for the ALARM events.

The function offers sixteen (16) independent stages; the events are segregated for each stage operation.

Table. 4.4.23 - 206. Event messages.

| Event block name | Event names              |
|------------------|--------------------------|
| RTD1             | S1...S16 Alarm1 ON/OFF   |
| RTD1             | S1...S16 Alarm2 ON/OFF   |
| RTD1             | S1...S16 Meas Ok/Invalid |

## 4.4.24 Programmable stage (PSx>/<; 99)

The programmable stage is a stage that the user can program to create more advanced applications, either as an individual stage or together with programmable logic. The device has ten programmable stages, and each can be set to follow one to three analog measurements. The programmable stages have three available pick up terms options: overX, underX and rate-of-change of the selected signal. Each stage includes a definite time delay to trip after a pick-up has been triggered.

The programmable stage cycle time is 5 ms. The pick-up delay depends on which analog signal is used as well as its refresh rate (typically under a cycle in a 50 Hz system).

The number of programmable stages to be used is set in the *INFO* tab. When this function has been set as "Activated", the number of programmable stages can be set anywhere between one (1) and ten (10) depending on how many the application needs. In the image below, the number of programmable stages have been set to two which makes PS1 and PS2 to appear. Inactive stages are hidden until they are activated.

Please note that setting the number of available stages does not activate those stages, as they also need to be enabled individually with the *PSx >/< Enabled* parameter. When enabled an active stage shows its current state (condition), the expected operating time and the time remaining to trip under the activation parameters. If a stage is not active the *PSx >/< condition* parameter will merely display "Disabled".

Setting group selection controls the operating characteristics of the function, i.e. the user or user-defined logic can change function parameters while the function is running.

### General settings

The following general settings define the general behavior of the function. These settings are static i.e. it is not possible to change them by editing the setting group.

Table. 4.4.24 - 207. General settings of the function.

| Name                     | Range  | Description  |
|--------------------------|--|--|
| PSx >/< LN mode          | <ul style="list-style-type: none"> <li>• On</li> <li>• Blocked</li> <li>• Test</li> <li>• Test/Blocked</li> <li>• Off</li> </ul> | Set mode of PSx block.<br>This parameter is visible only when <i>Allow setting of individual LN mode</i> is enabled in <i>General</i> menu.          |
| PSx >/< LN behaviour     | <ul style="list-style-type: none"> <li>• On</li> <li>• Blocked</li> <li>• Test</li> <li>• Test/Blocked</li> <li>• Off</li> </ul> | Displays the mode of PSx block.<br>This parameter is visible only when <i>Allow setting of individual LN mode</i> is enabled in <i>General</i> menu. |
| PSx >/< Available stages | 1...10   | Defines the available amount of stages.  |
| PSx >/< Enabled          | <ul style="list-style-type: none"> <li>• Disabled</li> <li>• Enabled</li> </ul>  | Enables the stage.   |
| PSx >/< Force status to  | <ul style="list-style-type: none"> <li>• Normal</li> <li>• Start</li> <li>• Trip</li> <li>• Blocked</li> </ul>                   | Force the status of the function. Visible only when <i>Enable stage forcing</i> parameter is enabled in <i>General</i> menu.                         |

| Name   | Range  | Description   |
|--|--|---|
| PSx >/< Measurement setting                                  | <ul style="list-style-type: none"> <li>• One magnitude comp</li> <li>• Two magnitude comp</li> <li>• Three magnitude comp</li> </ul>                       | Defines how many measurement magnitudes are used by the stage.  |
| PSx >/< Magnitude handling ("Two magnitude comp" selected)   | Mag1 x Mag2  | Multiplies Signal 1 by Signal 2. The comparison uses the product of this calculation.                           |
|  | Mag1 / Mag2  | Divides Signal 1 by Signal 2. The comparison uses the product of this calculation.                              |
|  | Max (Mag1, Mag2)   | The bigger value of the chosen signals is used in the comparison.   |
|  | Min (Mag1, Mag2)   | The smaller value of the chosen signals is used in the comparison.  |
|  | Mag1 OR Mag2   | Either of the chosen signals has to fulfill the pick-up condition. Both signals have their own pick-up setting. |
|  | Mag1 AND Mag2  | Both of the chosen signals have to fulfill the pick-up condition. Both signals have their own pick-up setting.  |
|  | Mag1 – Mag2  | Subtracts Signal 2 from Signal 1. The comparison uses the product of this calculation.                          |
| PSx >/< Magnitude handling ("Three magnitude comp" selected) | Mag1 x Mag2 x Mag3   | Multiplies Signals 1, 2 and 3. The comparison uses the product of this calculation.                             |
|  | Max (Mag1, Mag2, Mag3);  | The biggest value of the chosen signals is used in the comparison.  |
|  | Min (Mag1, Mag2, Mag3)   | The smallest value of the chosen signals is used in the comparison.   |
|  | Mag1 OR Mag2 OR Mag3   | Any of the signals fulfills the pick-up condition. Each signal has their own pick-up setting.                   |
|  | Mag1 AND Mag2 AND Mag3   | All of the signals need to fulfill the pick-up condition. Each signal has their own pick-up setting.            |
|  | (Mag1 OR Mag2) AND Mag3  | Signals 1 OR 2 AND 3 need to fulfill the pick-up condition. Each signal has their own pick-up setting.          |
| PSx Magnitude selection                                      | <ul style="list-style-type: none"> <li>• Currents</li> <li>• Voltages</li> <li>• Powers</li> <li>• Impedances and admittances</li> <li>• Others</li> </ul> | Defines the measurement type used by the stage  |
| PSx MagnitudeX   | See table below.   | Defines the measurement used by the stage. Available parameters depend on selected measurement type.            |

| Name                      | Range                  | Description   |
|---------------------------|------------------------|---|
| PSx MagnitudeX multiplier | -5 000 000...5 000 000 | Multiplies the selected measurement. 1 by default (no multiplication). See section "Magnitude multiplier" for more information. |

## Analog values

The numerous analog signals have been divided into categories to help the user find the desired value.

Table. 4.4.24 - 208. Phase and residual current measurements (IL1, IL2, IL3, Io1 and Io2)

| Name                    | Description                                   |
|-------------------------|---|
| ILx ff (p.u.)           | Fundamental frequency RMS value (in p.u.)     |
| ILx 2 <sup>nd</sup> h.  | ILx 2 <sup>nd</sup> harmonic value (in p.u.)  |
| ILx 3 <sup>rd</sup> h.  | ILx 3 <sup>rd</sup> harmonic value (in p.u.)  |
| ILx 4 <sup>th</sup> h.  | ILx 4 <sup>th</sup> harmonic value (in p.u.)  |
| ILx 5 <sup>th</sup> h.  | ILx 5 <sup>th</sup> harmonic value (in p.u.)  |
| ILx 7 <sup>th</sup> h.  | ILx 7 <sup>th</sup> harmonic value (in p.u.)  |
| ILx 9 <sup>th</sup> h.  | ILx 9 <sup>th</sup> harmonic value (in p.u.)  |
| ILx 11 <sup>th</sup> h. | ILx 11 <sup>th</sup> harmonic value (in p.u.) |
| ILx 13 <sup>th</sup> h. | ILx 13 <sup>th</sup> harmonic value (in p.u.) |
| ILx 15 <sup>th</sup> h. | ILx 15 <sup>th</sup> harmonic value (in p.u.) |
| ILx 17 <sup>th</sup> h. | ILx 17 <sup>th</sup> harmonic value (in p.u.) |
| ILx 19 <sup>th</sup> h. | ILx 19 <sup>th</sup> harmonic value (in p.u.) |
| ILx TRMS                | ILx TRMS value (in p.u.)                      |
| ILx Ang                 | ILx Angle (degrees)                           |

Table. 4.4.24 - 209. Other current measurements

| Name       | Description                                    |
|------------|--|
| IOZ Mag    | Zero sequence current value (in p.u.)          |
| IOCALC Mag | Calculated IO value (in p.u.)                  |
| I1 Mag     | Positive sequence current value (in p.u.)      |
| I2 Mag     | Negative sequence current value (in p.u.)      |
| IOCALC Ang | Angle of calculated residual current (degrees) |

| Name    | Description   |
|---------|---|
| I1 Ang  | Angle of positive sequence current (degrees)            |
| I2 Ang  | Angle of negative sequence current (degrees)            |
| I01ResP | I01 primary current of a current-resistive component    |
| I01CapP | I01 primary current of a current-capacitive component   |
| I01ResS | I01 secondary current of a current-resistive component  |
| I01CapS | I01 secondary current of a current-capacitive component |
| I02ResP | I02 primary current of a current-resistive component    |
| I02CapP | I02 primary current of a current-capacitive component   |
| I02ResS | I02 secondary current of a current-resistive component  |
| I02CapS | I02 secondary current of a current-capacitive component |

Table. 4.4.24 - 210. Voltage measurements

| Name             | Description                                 |
|------------------|---|
| UL12Mag          | UL12 Primary voltage V                      |
| UL23Mag          | UL23 Primary voltage V                      |
| UL31Mag          | UL31 Primary voltage V                      |
| UL1Mag           | UL1 Primary voltage V                       |
| UL2Mag           | UL2 Primary voltage V                       |
| UL3Mag           | UL3 Primary voltage V                       |
| UL12Ang          | UL12 angle (degrees)                        |
| UL23Ang          | UL23 angle (degrees)                        |
| UL31Ang          | UL31 angle (degrees)                        |
| UL1Ang           | UL1 angle (degrees)                         |
| UL2Ang           | UL2 angle (degrees)                         |
| UL3Ang           | UL3 angle (degrees)                         |
| U0Ang            | UL0 angle (degrees)                         |
| U0CalcMag        | Calculated residual voltage                 |
| U1 pos.seq.V Mag | Positive sequence voltage                   |
| U2 neg.seq.V Mag | Negative sequence voltage                   |
| U0CalcAng        | Calculated residual voltage angle (degrees) |
| U1 pos.seq.V Ang | Positive sequence voltage angle (degrees)   |

| Name             | Description  |
|------------------|--|
| U2 neg.seq.V Ang | Negative sequence voltage angle (degrees)  |
| U3SMag           | U3 channel voltage magnitude when the channel is set to "SS" mode                    |
| U3SAng           | U3 channel voltage angle when the channel is set to "SS" mode                        |
| U4SMag           | U4 channel voltage magnitude when the channel is set to "SS" mode                    |
| U4SAng           | U4 channel voltage angle when the channel is set to "SS" mode                        |
| T1 Tap U         | Voltage measured by the AVR function in the T1 device (in parallel tap changer mode) |
| T2 Tap U         | Voltage measured by the AVR function in the T2 device (in parallel tap changer mode) |
| T3 Tap U         | Voltage measured by the AVR function in the T3 device (in parallel tap changer mode) |
| T4 Tap U         | Voltage measured by the AVR function in the T4 device (in parallel tap changer mode) |

Table. 4.4.24 - 211. Power measurements

| Name     | Description                                 |
|----------|---|
| S3PH     | Three-phase apparent power S (kVA)          |
| P3PH     | Three-phase active power P (kW)             |
| Q3PH     | Three-phase reactive power Q (kvar)         |
| tanfi3PH | Three-phase active power direction          |
| cosfi3PH | Three-phase reactive power direction        |
| SLx      | Phase apparent power L1 / L2 / L3 S (kVA)   |
| PLx      | Phase active power L1 / L2 / L3 P (kW)      |
| QLx      | Phase reactive power L1 / L2 / L3 Q (kVar)  |
| tanfiLx  | Phase active power direction L1 / L2 / L3   |
| cosfiLx  | Phase reactive power direction L1 / L2 / L3 |
| PoFaLx   | Phase power factor L1 / L2 / L3             |
| PoFa3PH  | Three-phase power factor                    |

Table. 4.4.24 - 212. Phase-to-phase and phase-to-neutral impedances, resistances and reactances

| Name   | Description   |
|--------|---|
| RLxPri | Resistance R L12, L23, L31, L1, L2, L3 primary ( $\Omega$ )   |
| XLxPri | Reactance X L12, L23, L31, L1, L2, L3 primary ( $\Omega$ )    |
| ZLxPri | Impedance Z L12, L23, L31, L1, L2, L3 primary ( $\Omega$ )    |
| RLxSec | Resistance R L12, L23, L31, L1, L2, L3 secondary ( $\Omega$ ) |

| Name     | Description  |
|----------|--|
| XLxSec   | Reactance X L12, L23, L31, L1, L2, L3 secondary ( $\Omega$ ) |
| ZLxSec   | Impedance Z L12, L23, L31, L1, L2, L3 secondary ( $\Omega$ ) |
| ZLxAngle | Impedance Z L12, L23, L31, L1, L2, L3 angle                  |

Table. 4.4.24 - 213. Other impedances, resistances and reactances

| Name      | Description                                  |
|-----------|--|
| RSeqPri   | Positive Resistance R primary ( $\Omega$ )   |
| XSeqPri   | Positive Reactance X primary ( $\Omega$ )    |
| RSeqSec   | Positive Resistance R secondary ( $\Omega$ ) |
| XSeqSec   | Positive Reactance X secondary ( $\Omega$ )  |
| ZSeqPri   | Positive Impedance Z primary ( $\Omega$ )    |
| ZSeqSec   | Positive Impedance Z secondary ( $\Omega$ )  |
| ZSeqAngle | Positive Impedance Z angle                   |

Table. 4.4.24 - 214. Conductances, susceptances and admittances (L1, L2, L3)

| Name      | Description                             |
|-----------|---|
| GLxPri    | Conductance G L1, L2, L3 primary (mS)   |
| BLxPri    | Susceptance B L1, L2, L3 primary (mS)   |
| YLxPriMag | Admittance Y L1, L2, L3 primary (mS)    |
| GLxSec    | Conductance G L1, L2, L3 secondary (mS) |
| BLxSec    | Susceptance B L1, L2, L3 secondary (mS) |
| YLxSecMag | Admittance Y L1, L2, L3 secondary (mS)  |
| YLxAngle  | Admittance Y L1, L2, L3 angle (degrees) |

Table. 4.4.24 - 215. Other conductances, susceptances and admittances

| Name  | Description                   |
|-------|-------------------------------|
| G0Pri | Conductance G0 primary (mS)   |
| B0Pri | Susceptance B0 primary (mS)   |
| G0Sec | Conductance G0 secondary (mS) |
| B0Sec | Susceptance B0 secondary (mS) |
| Y0Pri | Admittance Y0 primary (mS)    |

| Name    | Description                  |
|---------|------------------------------|
| Y0Sec   | Admittance Y0 secondary (mS) |
| Y0Angle | Admittance Y0 angle          |

Table. 4.4.24 - 216. Other measurements

| Name                 | Description                                    |
|----------------------|--|
| System f.            | System frequency                               |
| Ref f1               | Reference frequency 1                          |
| Ref f2               | Reference frequency 2                          |
| M Thermal T          | Motor thermal temperature                      |
| F Thermal T          | Feeder thermal temperature                     |
| T Thermal T          | Transformer thermal temperature                |
| RTD meas 1...16      | RTD measurement channels 1...16                |
| Ext RTD meas 1...8   | External RTD measurement channels 1...8 (ADAM) |
| mA input 7,8,15,16   | mA input channels 7, 8, 15, 16                 |
| ASC 1...4            | Analog scaled curves 1...4                     |
| mAln1...4 (Tcard1/2) | mA input channels in T option card(s)          |

### Magnitude multiplier

Programmable stages can be set to follow one, two or three analog measurements with the *PSx >/< Measurement setting* parameter. The user must choose a measurement signal value to be compared to the set value, and possibly also set a scaling for the signal. The image below is an example of scaling: a primary zero sequence voltage has been scaled to a percentage value for easier handling when setting up the comparator.

The scaling factor was calculated by taking the inverse value of a 20 kV system:

$$k = \frac{1}{20\,000\text{ V}/\sqrt{3}} = 0.008\,66$$

When this multiplier is in use, the full earth fault zero sequence voltage is 11 547 V primary which is then multiplied with the above-calculated scaling factor, inverting the final result to 100%. This way a pre-processed signal is easier to set, although it is also possible to just use the scaling factor of 1.0 and set the desired pick-up limit as the primary voltage. Similarly, any chosen measurement value can be scaled to the desired form.

### Read-only parameters

The function's *Info* page displays useful, real-time information on the state of the protection function. It is accessed either through the device's HMI display, or through the setting tool software when it is connected to the device and its Live Edit mode is active.

Table. 4.4.24 - 217. Information displayed by the function.

| Name                                      | Range  | Description  |
|---|--|--|
| PSx >/< LN behaviour                      | <ul style="list-style-type: none"> <li>• On</li> <li>• Blocked</li> <li>• Test</li> <li>• Test/Blocked</li> <li>• Off</li> </ul> | Displays the mode of PSx block.<br>This parameter is visible only when <i>Allow setting of individual LN mode</i> is enabled in <i>General</i> menu. |
| Condition                                 | <ul style="list-style-type: none"> <li>• Normal</li> <li>• Start</li> <li>• Trip</li> <li>• Blocked</li> </ul>                   | Displays status of the function.   |
| Expected operating time                   | -1800.000...1800.000s  | Displays the expected operating time when a fault occurs.  |
| Time remaining to trip                    | 0.000...1800.000s  | When the function has detected a fault and counts down time towards a trip, this displays how much time is left before tripping occurs.              |
| PSx Scaled magnitude X                    | -5 000 000...5 000 000   | Displays measurement value after multiplying it the value set to <i>PSx Magnitude multiplier</i> .   |
| PSx >/< MeasMag1/ MagSet1 at the moment   | -5 000 000...5 000 000   | The ratio between measured magnitude and the pick-up setting.  |
| PSx >/< MeasMag2/ MagSet2 at the moment   | -5 000 000...5 000 000   | The ratio between measured magnitude and the pick-up setting.  |
| PSx >/< MeasMag3/ MagSet3 at the moment   | -5 000 000...5 000 000   | The ratio between measured magnitude and the pick-up setting.  |
| PSx >/< CalcMeasMag/ MagSet at the moment | -5 000 000...5 000 000   | The ratio between calculated magnitude and the pick-up setting.  |

### Pick-up settings

The *Pick-up setting Mag* setting parameter controls the pick-up of the PSx>/< function. This defines the maximum or minimum allowed measured magnitude before action from the function. The function constantly calculates the ratio between the set and the measured magnitudes. The user can set the reset hysteresis in the function (by default 3 %). It is always relative to the *Pick-up setting Mag* value.

Table. 4.4.24 - 218. Pick-up settings.

| Name                              | Range  | Step    | Default | Description   |
|-----------------------------------|--|---------|---------|---|
| PS# Pick-up term Mag#             | <ul style="list-style-type: none"> <li>• Over &gt;</li> <li>• Over (abs) &gt;</li> <li>• Under &lt;</li> <li>• Under (abs) &lt;</li> <li>• Delta set (%) +/- &gt;</li> <li>• Delta abs (%) &gt;</li> <li>• Delta +/- measval</li> <li>• Delta abs measval</li> </ul> | -       | Over    | Comparator mode for the magnitude. See "Comparator modes" section below for more information. |
| PS# Pick-up setting Mag#/calc >/< | -5 000<br>000.0000...5 000<br>000.0000   | 0.0001  | 0.01    | Pick-up magnitude   |
| PS# Setting hysteresis Mag#       | 0.0000...50.0000%  | 0.0001% | 3%      | Setting hysteresis  |
| Definite operating time delay     | 0.000...1800.000s  | 0.005s  | 0.04s   | Delay setting   |
| Release time delays               | 0.000...1800.000s  | 0.005s  | 0.06s   | Pick-up release delay   |

## Comparator modes

When setting the comparators, the user must first choose a comparator mode.

Table. 4.4.24 - 219. Comparator modes

| Mode                | Description  |
|---------------------|--|
| Over >              | <b>Greater than.</b> If the measured signal is greater than the set pick-up level, the comparison condition is fulfilled.  |
| Over (abs) >        | <b>Greater than (absolute).</b> If the absolute value of the measured signal is greater than the set pick-up level, the comparison condition is fulfilled.   |
| Under <             | <b>Less than.</b> If the measured signal is less than the set pick-up level, the comparison condition is fulfilled. The user can also set a blocking limit: the comparison is not active when the measured value is less than the set blocking limit.                                  |
| Under (abs) <       | <b>Less than (absolute).</b> If the absolute value of the measured signal is less than the set pick-up level, the comparison condition is fulfilled. The user can also set a blocking limit: the comparison is not active when the measured value is less than the set blocking limit. |
| Delta set (%) +/- > | <b>Relative change over time.</b> If the measured signal changes more than the set relative pick-up value in 20 ms, the comparison condition is fulfilled. The condition is dependent on direction.  |
| Delta abs (%) >     | <b>Relative change over time (absolute).</b> If the measured signal changes more than the set relative pick-up value in 20 ms in either direction, the comparison condition is fulfilled. The condition is not dependent on direction.   |

| Mode              | Description  |
|-------------------|--|
| Delta +/- measval | <b>Change over time.</b> If the measured signal changes more than the set pick-up value in 20 ms, the comparison condition is fulfilled. The condition is dependent on direction.                                    |
| Delta abs measval | <b>Change over time (absolute).</b> If the measured signal changes more than the set pick-up value in 20 ms in either direction, the comparison condition is fulfilled. The condition is not dependent on direction. |

The pick-up level is set individually for each comparison. When setting up the pick-up level, the user needs to take into account the modes in use as well as the desired action. The pick-up limit can be set either as positive or as negative. Each pick-up level has a separate hysteresis setting which is 3 % by default.

The user can set the operating and releasing time delays for each stage.

### Function blocking

The blocking signal is evaluated at the start of each program cycle. The blocking signals are connected to the function's dedicated input, which can be configured in the *IO* → *Blocking Input Control* tab of the function.

- When the pick-up element activates and the blocking signal is not active, a START signal is generated, and the function starts or continues with the trip time countdown.
- When the pick-up element activates and the blocking signal is active, a BLOCKED signal is generated, and the function does not process the event further.
- When a START signal is already active and the blocking input signal becomes active, the START signal is reset and BLOCKED signal is generated. The release time characteristics are then processed in the same way as when the pick-up signal is reset.

The blocking signal needs to reach the device minimum of 5 ms before the set operating delay has passed in order for the blocking to activate in time.

### Events and registers

The programmable stage function (abbreviated "PSx" in event block names) generates events and registers from the status changes in the events listed below. The user can select which event messages are stored in the main event buffer: ON, OFF, or both. The events triggered by the function are recorded with a time stamp.

The function's outputs can be used for direct I/O controlling and user logic programming. The function also provides a resettable cumulative counter for the START, TRIP and BLOCKED events.

Table. 4.4.24 - 220. Event messages.

| Event block name | Event names               |
|------------------|---------------------------|
| PSx              | PS1...10 >/< Start ON/OFF |
| PSx              | PS1...10 >/< Trip ON/OFF  |
| PSx              | PS1...10 >/< Block ON/OFF |

The function registers its operation into the last twelve (12) time-stamped registers. The register of the function records the ON event process data for START, TRIP or BLOCKED. The table below presents the structure of the function's register content.

Table. 4.4.24 - 221. Register content.

| Register             | Description  |
|----------------------|--|
| Date and time        | dd.mm.yyyy hh:mm:ss.mss                                      |
| Event                | Event name   |
| >/< Mag#             | The numerical value of the magnitude                         |
| Mag#/Set#            | Ratio between the measured magnitude and the pick-up setting |
| Trip time remaining  | 0 ms...1800s   |
| Setting group in use | Setting group 1...8 active                                   |

### 4.4.25 Arc fault protection (IArc>/IOArc>; 50Arc/50NArc)

Arc faults occur for a multitude of reasons: e.g. insulation failure, incorrect operation of the protected device, corrosion, overvoltage, dirt, moisture, incorrect wiring, or even because of aging caused by electric load. It is important to detect the arc as fast as possible in order to minimize its effects. Using arc sensors to detect arc faults is much faster than merely measuring currents and voltages. In busbar protection devices with normal protection can be too slow to disconnect arcs within a safe time frame. For example, it may be necessary to delay operation time for hundreds of milliseconds when setting up an overcurrent protection relay to control the feeder breakers to achieve selectivity. This delay can be avoided by using arc protection. The arc protection card has a high-speed output to trip signals faster as well as to extend the speed of arc protection.

The arc protection card has four (4) sensor channels, and up to three (3) arc point sensors can be connected to each channel. The sensor channels support Arc-teq AQ-01 (light detecting) and AQ-02 (pressure and light detecting) sensors. Optionally, the protection function can also be applied with a phase current or a residual current condition: the function trips only if the light and overcurrent conditions are met.

Table. 4.4.25 - 222. Output signals of the IArc>/IOArc> function.

| Outputs  | Activation condition  |
|--|---|
| Channel 1 Light In<br>Channel 2 Light In<br>Channel 3 Light In<br>Channel 4 Light In | The arc protection card's sensor channel detects light.                       |
| ARC Binary input signal  | The arc protection card's binary input is energized.                          |
| I/O Arc> Ph. curr. START<br>I/O Arc> Res. curr. START                                | The measured phase current or the residual current is over the set limit.     |
| I/O Arc> Ph. curr. BLOCKED<br>I/O Arc> Res. curr. BLOCKED                            | The phase current or the residual current measurement is blocked by an input. |

| Outputs  | Activation condition  |
|--|---|
| I/O Arc> Zone 1 TRIP<br>I/O Arc> Zone 2 TRIP<br>I/O Arc> Zone 3 TRIP<br>I/O Arc> Zone 4 TRIP                             | All required conditions for tripping the zone are met (light OR light and current).   |
| I/O Arc> Zone 1<br>BLOCKED<br>I/O Arc> Zone 2<br>BLOCKED<br>I/O Arc> Zone 3<br>BLOCKED<br>I/O Arc> Zone 4<br>BLOCKED     | All required conditions for tripping the zone are met (light OR light and current) but the tripping is blocked by an input. |
| I/O Arc> S1 Sensor<br>fault<br>I/O Arc> S2 Sensor<br>fault<br>I/O Arc> S3 Sensor<br>fault<br>I/O Arc> S4 Sensor<br>fault | The detected number of sensors in the channel does not match the settings.  |
| I/O Arc> IO unit fault   | The number of connected AQ-100 series units does not match the number of units set in the settings.                         |

### Example of scheme setting

The following examples help the user better understand how the arc protection function is set. In the examples AQ-101 models are used to extend the protection of Zone 2 and to protect each outgoing feeder (Zone 3).

This scheme is a single-line diagram with a protection relay equipped with an arc protection option card at the incoming feeder and with AQ-101 arc protection relays installed to the outgoing feeders.

Figure. 4.4.25 - 115. Scheme with AQ-101 arc protection relays.

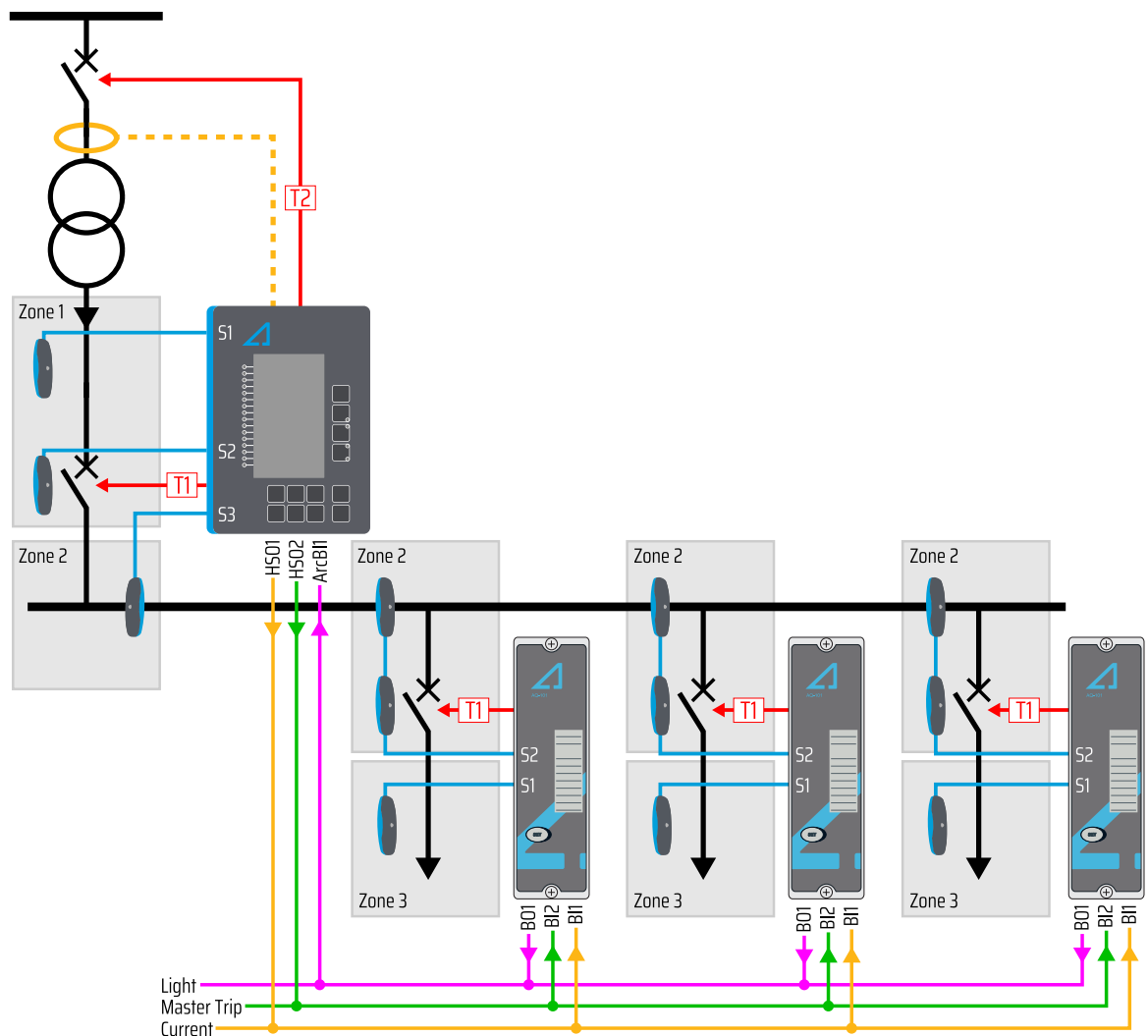

To set the zones for the device installed to the incoming feeder, start by enabling the protected zones (in this case, Zones 1 and 2). Then define which sensor channels are sensing which zones:

- Channel 1: Installed to incoming feeder cable compartment. Enabled in Zone 1.
- Channel 2: Installed to incoming feeder circuit breaker compartment. Enabled in Zone 1.
- Channel 3: Installed to busbar. Enabled in Zone 2.

The high-speed output contacts HSO1 and HSO2 have been set to send overcurrent and master trip signals to the AQ-101 arc protection relays. The AQ 100 series devices binary outputs (BO1) send test pulses once a second to check the health of the wiring between the AQ 100 series units and the binary input "ArcBI1" in the device installed to the incoming feeder. The parameter *I/O Arc > Self supervision test pulse* should be activated when connecting the AQ 100 series units to the main unit to prevent the pulses from activating ArcBI1.

The next example is similar to the previous one. However, this time each outgoing feeder has an AQ 250 protection device instead of an AQ-101 arc protection relay.

Figure. 4.4.25 - 116. Scheme with protection devices.

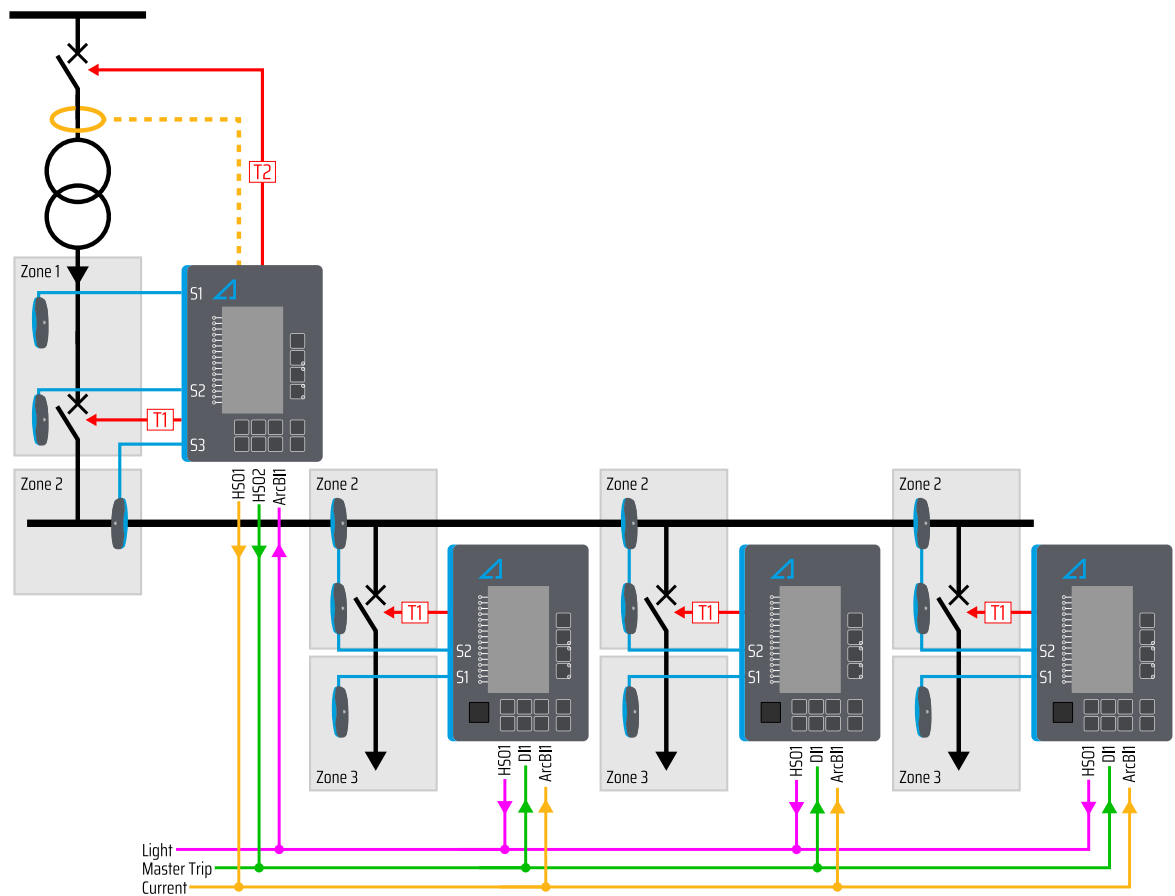

The settings for the device supervising the incoming feeder are the same as in the first example. The devices supervising the busbar and the outgoing feeder, however, use different settings:

- Channel 1: Installed to outgoing feeder cable compartment. Enabled in Zone 3.
- Channel 2: Installed to outgoing feeder circuit breaker compartment and the busbar. Enabled in Zone 2.

If either phase overcurrent or residual overcurrent is needed for the tripping decision, they can be enabled in the same way as light sensors in the zone. When a current channel is enabled, the measured current needs to be above the set current limit in addition to light sensing for the zone to trip.

### Measured input

Arc protection uses samples based on current measurements. If the required number of samples is found to be above the setting limit, the current condition activates. The arc protection can use either phase currents, residual currents or both.

Table. 4.4.25 - 223. Measurement inputs of the U1/U2>/< function.

| Signal                  | Description   |
|-------------------------|---|
| I <sub>L1</sub> samples | Samples received by I <sub>L1</sub> current measurement channel |
| I <sub>L2</sub> samples | Samples received by I <sub>L2</sub> current measurement channel |
| I <sub>L3</sub> samples | Samples received by I <sub>L3</sub> current measurement channel |

| Signal      | Description   |
|-------------|---|
| l01 samples | Samples received by l01 current measurement channel |
| l02 samples | Samples received by l02 current measurement channel |

## General settings

The following general settings define the general behavior of the function. These settings are static i.e. it is not possible to change them by editing the setting group.

Table. 4.4.25 - 224. General settings of the function.

| Name                                  | Range   | Default    | Description   |
|---------------------------------------|---|------------|---|
| I/I0<br>Arc> LN<br>mode               | <ul style="list-style-type: none"> <li>• On</li> <li>• Blocked</li> <li>• Test</li> <li>• Test/Blocked</li> <li>• Off</li> </ul>  | On         | Set mode of ARC block.<br>This parameter is visible only when <i>Allow setting of individual LN mode</i> is enabled in <i>General</i> menu. |
| I/I0<br>Arc><br>force<br>status<br>to | <ul style="list-style-type: none"> <li>• Normal</li> <li>• PH curr blocked</li> <li>• PH curr Start</li> <li>• ResCurr Blocked</li> <li>• ResCurr Start</li> <li>• Zone 1 Trip Blocked</li> <li>• Zone1 Blocked</li> <li>• Zone2 Trip Blocked</li> <li>• Zone2 Blocked</li> <li>• Zone3 Trip Blocked</li> <li>• Zone3 Blocked</li> <li>• Zone4 Trip Blocked</li> <li>• Zone4 Blocked</li> </ul> | Normal     | Force the status of the function. Visible only when <i>Enable stage forcing</i> parameter is enabled in <i>General</i> menu.                |
| Channel 1 sensors                     | <ul style="list-style-type: none"> <li>• No sensors</li> <li>• 1 sensor</li> <li>• 2 sensors</li> <li>• 3 sensors</li> </ul>  | No sensors | Defines the number of sensors connected to the channel (channels 1/2/3/4). Used for supervising the health of the connection.               |
| Channel 2 sensors                     |   |            |   |
| Channel 3 sensors                     |   |            |   |
| Channel 4 sensors                     |   |            |   |

| Name                    | Range   | Default | Description  |
|-------------------------|---|---------|--|
| Channel 1 sensor status | <ul style="list-style-type: none"> <li>Sensors OK</li> <li>Configuration fault state</li> </ul> | -       | Displays the status of the sensor channel. If the number of sensors connected to the channel does not match with the set "Channel 1/2/3/4 sensors" setting, this parameter will go to the "Configuration fault" state. |
| Channel 2 sensor status |   |         |  |
| Channel 3 sensor status |   |         |  |
| Channel 4 sensor status |   |         |  |

### Pick-up settings

The pick-up of each zone of the `Iarc>/I0arc>` function is controlled by one of the following: the phase current pick-up setting, the residual current pick-up setting, or the sensor channels. The pick-up setting depends on which of these are activated in the zone.

Setting group selection controls the operating characteristics of the function, i.e. the user or user-defined logic can change function parameters while the function is running.

Table. 4.4.25 - 225. Enabled Zone pick-up settings.

| Name                     | Range  | Step                    | Default             | Description  |
|--------------------------|--|-------------------------|---------------------|--|
| Phase current pick-up    | 0.05...40.00<br>$\times I_n$   | 0.01<br>$\times I_n$    | 1.2 $\times I_n$    | The phase current measurement's pick-up value (in p.u.).                 |
| I0 input selection       | <ul style="list-style-type: none"> <li>None</li> <li>I01</li> <li>I02</li> </ul> | -                       | None                | Selects the residual current channel (I01 or I02).                       |
| Res.current pick-up      | 0.05...40.00<br>$\times I_{0n}$  | 0.01<br>$\times I_{0n}$ | 1.2 $\times I_{0n}$ | The residual current measurement's pick-up value (in p.u.).              |
| ZoneX Enabled            | <ul style="list-style-type: none"> <li>Disabled</li> <li>Enabled</li> </ul>      | -                       | Disabled            | Enables the chosen zone. Up to 4 zones can be enabled.                   |
| ZoneX Ph. curr. Enabled  | <ul style="list-style-type: none"> <li>Disabled</li> <li>Enabled</li> </ul>      | -                       | Disabled            | The phase overcurrent allows the zone to trip when light is detected.    |
| ZoneX Res. curr. Enabled | <ul style="list-style-type: none"> <li>Disabled</li> <li>Enabled</li> </ul>      | -                       | Disabled            | The residual overcurrent allows the zone to trip when light is detected. |
| ZoneX Light 1 Enabled    | <ul style="list-style-type: none"> <li>Disabled</li> <li>Enabled</li> </ul>      | -                       | Disabled            | Light detected in sensor channel 1 trips the zone.                       |

| Name                        | Range  | Step | Default  | Description  |
|-----------------------------|--|------|----------|--|
| ZoneX<br>Light 2<br>Enabled | <ul style="list-style-type: none"> <li>Disabled</li> <li>Enabled</li> </ul>                      | -    | Disabled | Light detected in sensor channel 2 trips the zone.   |
| ZoneX<br>Light 3<br>Enabled | <ul style="list-style-type: none"> <li>Disabled</li> <li>Enabled</li> </ul>                      | -    | Disabled | Light detected in sensor channel 3 trips the zone.   |
| ZoneX<br>Light 4<br>Enabled | <ul style="list-style-type: none"> <li>Disabled</li> <li>Enabled</li> </ul>                      | -    | Disabled | Light detected in sensor channel 4 trips the zone.   |
| ZoneX DI<br>Enabled         | <ul style="list-style-type: none"> <li>Disabled</li> <li>Light In</li> <li>Current In</li> </ul> | -    | Disabled | Arc protection option card digital input function selection. "Light In" mode trips the zone when digital input is active. In "Current In" mode digital input must be active at the same time as any of the sensor channels for the zone to trip. |

### Read-only parameters

The function's *Info* page displays useful, real-time information on the state of the protection function. It is accessed either through the device's HMI display, or through the setting tool software when it is connected to the device and its Live Edit mode is active.

Table. 4.4.25 - 226. Information displayed by the function.

| Name                     | Range  | Description  |
|--------------------------|--|--|
| I/O Arc> LN<br>behaviour | <ul style="list-style-type: none"> <li>On</li> <li>Blocked</li> <li>Test</li> <li>Test/Blocked</li> <li>Off</li> </ul>   | Displays the mode of ARC block.<br>This parameter is visible only when <i>Allow setting of individual LN mode</i> is enabled in <i>General</i> menu. |
| I/O Arc><br>condition    | <ul style="list-style-type: none"> <li>Z1 Trip</li> <li>Z1 Blocked</li> <li>Z2 Trip</li> <li>Z2 Blocked</li> <li>Z3 Trip</li> <li>Z3 Blocked</li> <li>Z4 Trip</li> <li>Z4 Blocked</li> </ul> | Displays status of the protection function.  |

|               |   |   |
|---------------|---|---|
| Sensor status | <ul style="list-style-type: none"> <li>• Ph Curr Blocked</li> <li>• Ph Curr Start</li> <li>• Res Curr Blocked</li> <li>• Res Curr Start</li> <li>• Channel1 Light</li> <li>• Channel1 Pressure</li> <li>• Channel2 Light</li> <li>• Channel2 Pressure</li> <li>• Channel3 Light</li> <li>• Channel3 Pressure</li> <li>• Channel4 Light</li> <li>• Channel4 Pressure</li> <li>• Digital input</li> <li>• I/O Arc&gt; Sensor 1 Fault</li> <li>• I/O Arc&gt; Sensor 2 Fault</li> <li>• I/O Arc&gt; Sensor 3 Fault</li> <li>• I/O Arc&gt; Sensor 4 Fault</li> <li>• I/O Arc&gt; I/O-unit Fault</li> </ul> | Displays the general status of sensors. |
|---------------|---|---|

### Function blocking

The block signal is checked in the beginning of each program cycle. The blocking signal is received from the blocking matrix in the function's dedicated input. If the blocking signal is not activated when the pick-up element activates, a TRIP signal is generated.

If the blocking signal is active when the pick-up element activates, a BLOCKED signal is generated and the function does not process the situation further.

The variables the user can set are binary signals from the system. The blocking signal needs to reach the device minimum of 5 ms before the set operating delay has passed in order for the blocking to activate in time.

### Events and registers

The arc fault protection function (abbreviated "ARC" in event block names) generates events and registers from the status changes in the events listed below. The user can select which event messages are stored in the main event buffer: ON, OFF, or both. The events triggered by the function are recorded with a time stamp.

The function's outputs can be used for direct I/O controlling and user logic programming. The function also provides a resettable cumulative counter for the events.

Table. 4.4.25 - 227. Event messages.

| Event block name | Event names            |
|------------------|------------------------|
| ARC1             | Zone 1...4 Trip ON/OFF |

| Event block name | Event names                           |
|------------------|---------------------------------------|
| ARC1             | Zone 1...4 Block ON/OFF               |
| ARC1             | Phase current Blocked ON/OFF          |
| ARC1             | Phase current Start ON/OFF            |
| ARC1             | Residual current Blocked ON/OFF       |
| ARC1             | Residual current Start ON/OFF         |
| ARC1             | Channel 1...4 Light ON/OFF            |
| ARC1             | DI Signal ON/OFF                      |
| ARC1             | I/I0 Arc> Sensor 1...4 Fault ON/OFF   |
| ARC1             | I/I0 Arc> sub-unit count error ON/OFF |

The function registers its operation into the last twelve (12) time-stamped registers. The table below presents the structure of the function's register content.

Table. 4.4.25 - 228. Register content.

| Register             | Description                |
|----------------------|----------------------------|
| Date and time        | dd.mm.yyyy hh:mm:ss.mss    |
| Event                | Event name                 |
| Phase A current      | Trip current               |
| Phase B current      |                            |
| Phase C current      |                            |
| Residual current     |                            |
| Active sensors       | 1...4                      |
| Setting group in use | Setting group 1...8 active |

## 4.5 Control functions

### 4.5.1 Common signals

Common signals function has all protection function start and trip signals internally connected to Common START and TRIP output signals. When any of the activated protection functions generate a START or a TRIP signal, Common signals function will also generate the same signal.

#### General settings

The following general settings define the general behavior of the function. These settings are static i.e. it is not possible to change them by editing the setting group.

Table. 4.5.1 - 229. General settings of the function.

| Name                   | Range   | Default | Description  |
|------------------------|---|---------|--|
| Common force status to | <ul style="list-style-type: none"> <li>• Normal</li> <li>• Start</li> <li>• Trip</li> </ul> | Normal  | Force the status of the function. Visible only when <i>Enable stage forcing</i> parameter is enabled in <i>General</i> menu. |

Common signals function has all START and TRIP signals of protection functions internally connected to Common START and TRIP output signals. But it is also possible to assign extra signals to activate Common START and TRIP.

Table. 4.5.1 - 230. Common signals extra inputs.

| Name            | Description   |
|-----------------|---|
| Common Start In | Assign extra signals to activate common START signal. Please note that all protection function START signals are already assigned internally to Common START. |
| Common Trip In  | Assign extra signals to activate common TRIP signal. Please note that all protection function TRIP signals are already assigned internally to Common TRIP.    |

### Read-only parameters

The function's *Info* page displays useful, real-time information on the state of the protection function. It is accessed either through the device's HMI display, or through the setting tool software when it is connected to the device and its Live Edit mode is active.

Table. 4.5.1 - 231. Information displayed by the function.

| Name                     | Range   | Description                      |
|--------------------------|---|----------------------------------|
| Common signals condition | <ul style="list-style-type: none"> <li>• Normal</li> <li>• Start</li> <li>• Trip</li> </ul> | Displays status of the function. |

### Function blocking

Common signals function itself doesn't have blocking input signals. Blocking of tripping should be done in each protection function settings.

### Events

The common signals function (abbreviated "GNSIG" in event block names) generates events from the status changes in the events listed below. The user can select which event messages are stored in the main event buffer: ON, OFF, or both.

The function's outputs can be used for direct I/O controlling and user logic programming. The function also provides a resettable cumulative counter for the START and TRIP events.

The events triggered by the function are recorded with a time stamp.

Table. 4.5.1 - 232. Event messages.

| Event block name | Event names         |
|------------------|---------------------|
| GNSIG            | Common Start ON/OFF |
| GNSIG            | Common Trip ON/OFF  |

## 4.5.2 Automatic voltage regulator (90)

The automatic voltage regulator (abbreviated AVR in this document) is used for controlling secondary side voltage of the transformers that have an on-load tap changer (OLTC). A voltage regulator raises or lowers the secondary voltage based on the bus voltage measurements. Actual controlling takes place in the tap changer: increasing (or decreasing) the secondary winding causes an increase (or a decrease) in the transformer output voltage.

The transformer secondary voltage and bus voltage may vary based on changes and variations in the load, the load power factor, the transmission system, and the resistance and reactance of the load. The aim of using an automatic voltage regulator is to maintain a stable secondary voltage and thus make sure that the distribution voltage does not rise dangerously high or fall unusably low.

Utilities have to follow the regional, national and international regulations that specify the acceptable voltage range. For example, in Finland regulations (SFS-EN 50160) require that the distribution voltage is 230 V (phase-to-earth). Voltage quality measurement is done on a 10-minute average: 95 % of the measured voltages must be  $\pm 10$  % of the nominal voltage and all measured voltages must be +10...-15 % of the nominal voltage. This measurement is usually taken from 20/0.4 kV distribution transformers on MV overhead lines (rural areas) and cable networks (urban areas) so the 20kV medium voltage is the side where the voltage has to be controlled for all distribution transformers behind the feeding transformer by controlling the load tap changer. This control model is commonly called bus regulation.

Other uses for voltage control are, for example, reactive power control and optimization of the transmission lines.

### Features and configuration

The automatic voltage regulator features separate operating windows for voltage raise and lower commands. Both raise and lower commands have two operating stages with different operation voltage levels and operation times. First stage of both voltage raise and lower commands have common definite time delay for operation. Second stage voltage raise and lower commands have a common definite and inverse operating time, whereas undervoltage the in-built overcurrent function blocks all commands to raise or lower the voltage. The target voltage as well as the operating settings for the voltage windows can be changed by editing the setting groups. The tap changer's location is monitored with mA, RTD, or digital input channel voltage measurement. The position of the tap changer can be controlled automatically and manually. The AVR monitors the phase-to-phase voltage of the bus. External commands can block the operation of the AVR either by completely blocking the control algorithm, or by only blocking the control outputs.

The blocking signal and the setting group selection control the operating characteristics of the function, i.e. the user or user-defined logic can change function parameters while the function is running. The function has a total of eight (8) setting groups available.

The following examples present how to configure the automatic voltage regulator.

### General settings

General settings include the selection of the measurement reference voltage. Additionally, the measured phase-to-phase voltage and the measurement input (if U4 is used for voltage measurements) must be selected as well.

The image below two connection options for voltage measurement.

Figure. 4.5.2 - 117. Two connection options for voltage measurement.

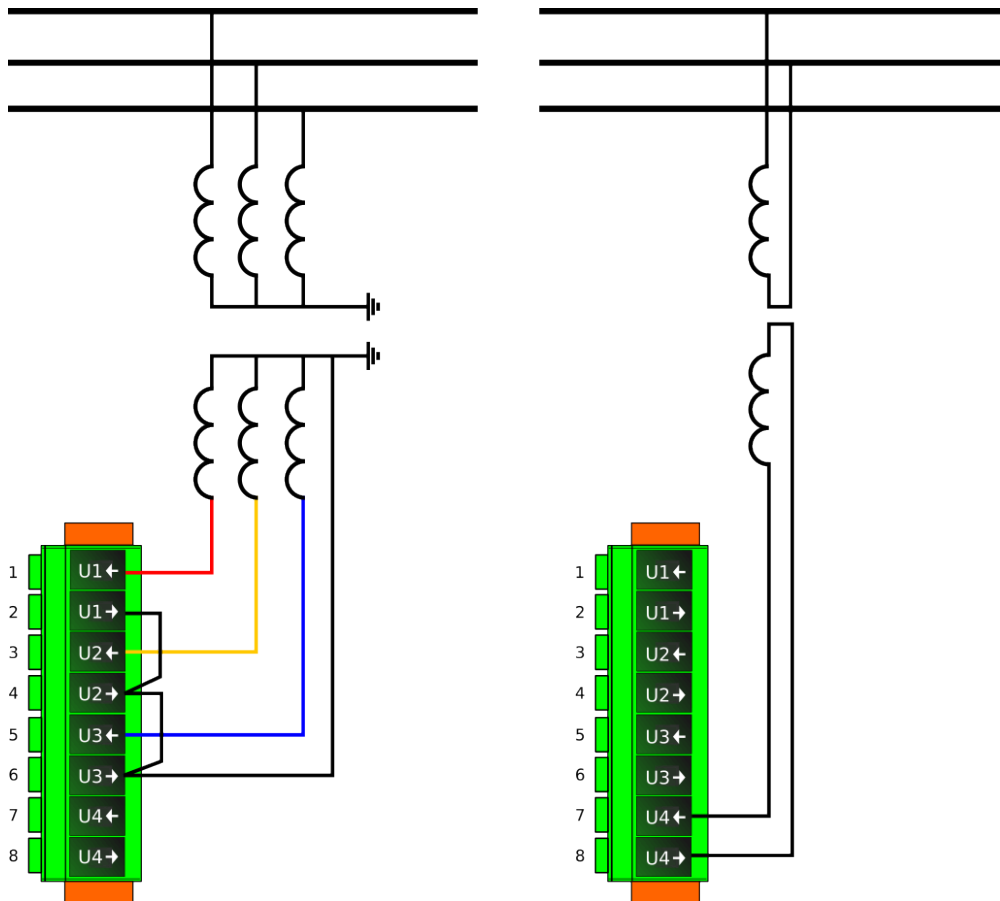

The connection on the left shows the voltage transformer module that has a full voltage connection with complete phase-to-phase or phase-to-earth voltages (3LN+U4; also on modes 3LL + U4 and 2LL+U3+U4); the AVR measurement voltage can be selected to be either U12, U23, or U31. If only one voltage is available for the AVR (the connection on the right), the regulator must be connected to the U4 input, and set to measure both from the U4 channel and from the connected voltage (U12, U23 or U31).

### Control settings

The control settings include the operating mode selection ("Auto" or "Manual") as well as the settings for the maximum and minimum control pulse lengths for the used output contacts. Additionally, the settings include the setting for the minimum instant operation wait time between pulses.

Below is an example of the settings that control pulse timings.

Figure. 4.5.2 - 118. Control pulse timing settings.

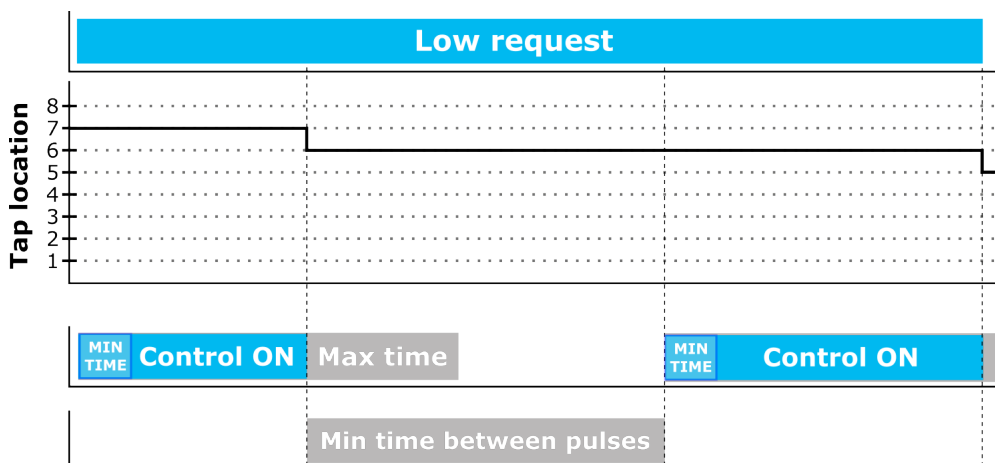

First, the user sets the minimum and maximum times for control pulses. If the tap changes location during the control pulse, and therefore also changing the voltage and the controlled direction, the command is terminated. If the set maximum control time is exceeded, the control signal is terminated even if tap location has not changed. After the termination, the set minimum time between pulses is used to prevent new control pulse outputs (esp. instant low requests) from taking place during this time.

### Tap settings

The properties of the used tap changer are set in the tap settings. They allow users to configure the number of tap changer positions, the middle position, and the position indication message. There are several different ways to connect tap position indication:

- mA input cards installed to the device
- External mA input units (ADAM-4016) connected to devices RS-485 serial port
- Binary coded inputs (with digital inputs)
- BCD coded inputs (with digital inputs)
- Measuring resistance with RTD channel
- Measuring voltage with a digital input

### mA input

For example, let us say a transformer has a tap changer with 19 positions, with position 9 presenting the middle position. The tap changer location is indicated by the mA signal (4...20 mA). Each tap position has a 1.67 % effect on the transformer's output voltage. The highest mA value is expected when the tap is in the highest position.

According to these data, the tap changer properties are set to the AVR as follows:

| Setting                                  | Value    |
|--|----------|
| Tap position indication                  | mA input |
| Tap total positions (absolute value 1-n) | 19 n     |
| Tap center (on absolute scale)           | 10       |
| Tap step effect                          | 1.67 %   |
| mA input low range                       | 4 mA     |
| mA input high range                      | 20 mA    |

| Setting                 | Value          |
|-------------------------|----------------|
| Tap position indication | Max.mA.max.Pos |

Based on these given values, the AVR function calculates the following:

| Calculation             | Value                   |
|-------------------------|-------------------------|
| Tap step voltage effect | 334 V <sub>pri</sub>    |
| Tap maximum decrease    | -15.03 %                |
| Tap maximum increase    | 15.03 %                 |
| Tap control band        | 30.06 %                 |
| Tap step in mA          | 0.889 mA                |
| mA input now            | measured mA input value |

These basic settings define the control area where the AVR must operate.

Either Channel 1 or 2 can be used to connect a mA input to an option card (see the image below).

Figure. 4.5.2 - 119. Connecting mA input to option card.

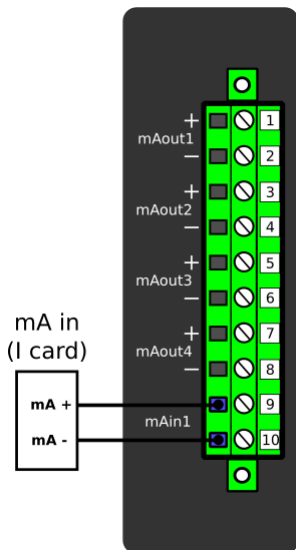
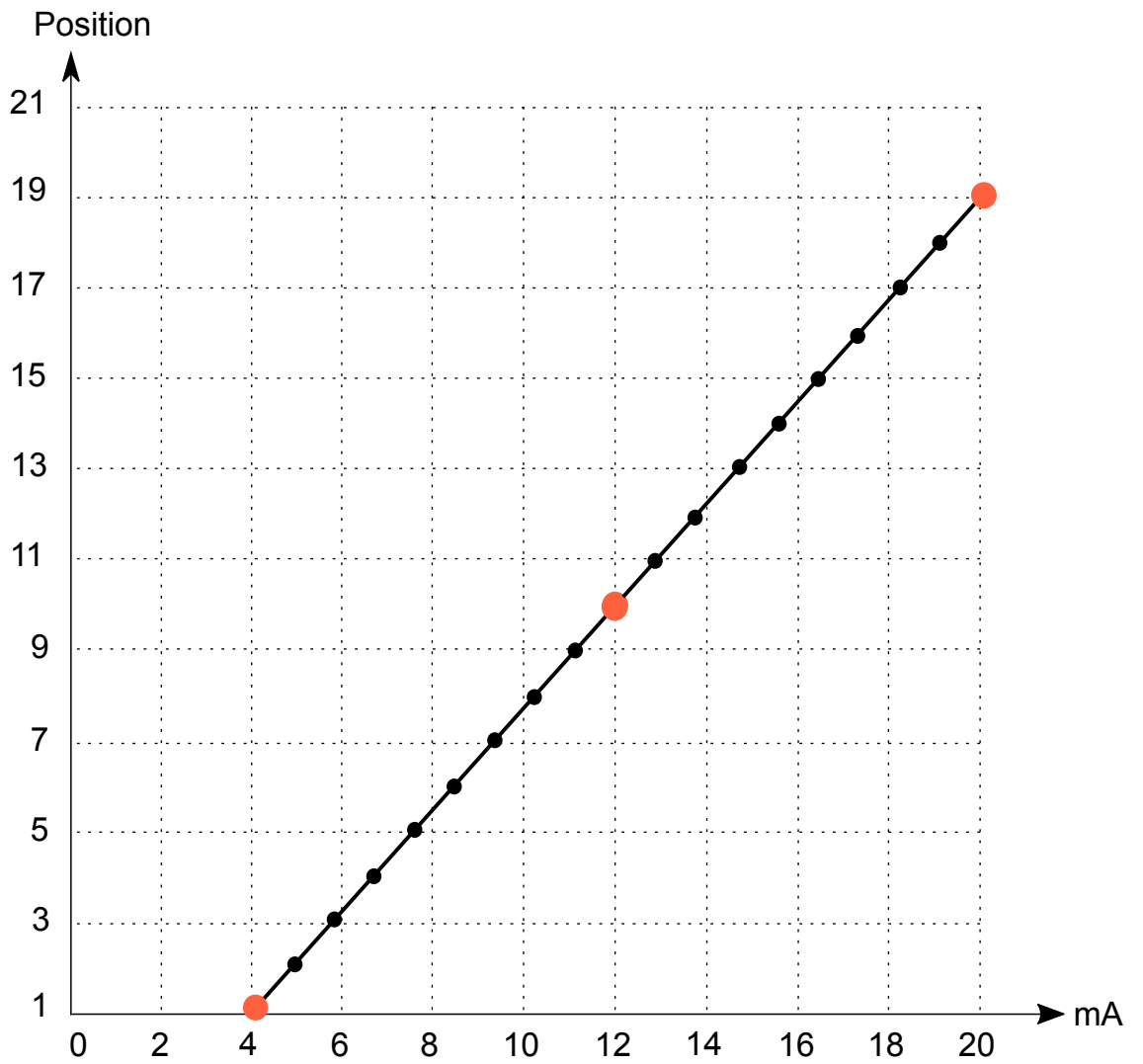
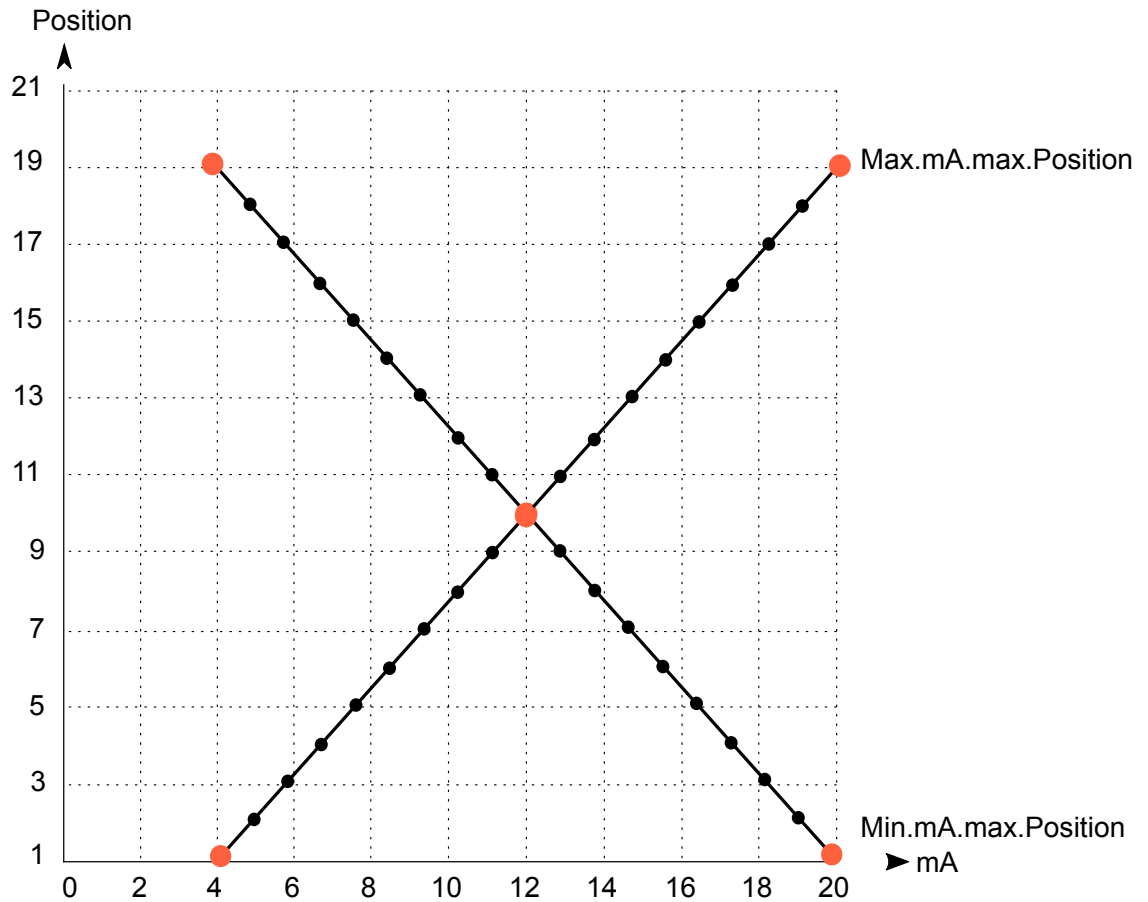

Figure. 4.5.2 - 120. Tap position indication (according to the example settings).



Some tap changers might work “inversely”, meaning that the maximum mA measurement indicates that the tap changer is in the lowest position. If this is the case, this can be switched with the “Tap position indication” parameter, as shown in the image below.

Figure. 4.5.2 - 121. Switching the tap position indication.



#### Correcting non-linear mA tap position indication with current scaling

When setting up the tap changer settings, it would be ideal to have the mA difference between each step be identical. However, this is not how it goes most of the time, and sometimes this non-linear increase can cause the AVR function to assume that the tap position has changed two or zero steps when in actuality the tap changer has been controlled for one step. This problem can be corrected by using the "Scaled input" mode, and then scaling the output value of the tap position that comes from the mA inputs at *Measurement* → *AI (mA, DI volt) scaling*. Below is an example where the tap changer has 19 positions (18 steps) and the mA/position curve has been corrected at two points between the minimum and maximum positions.

Figure. 4.5.2 - 122. Example of scaled input setting.

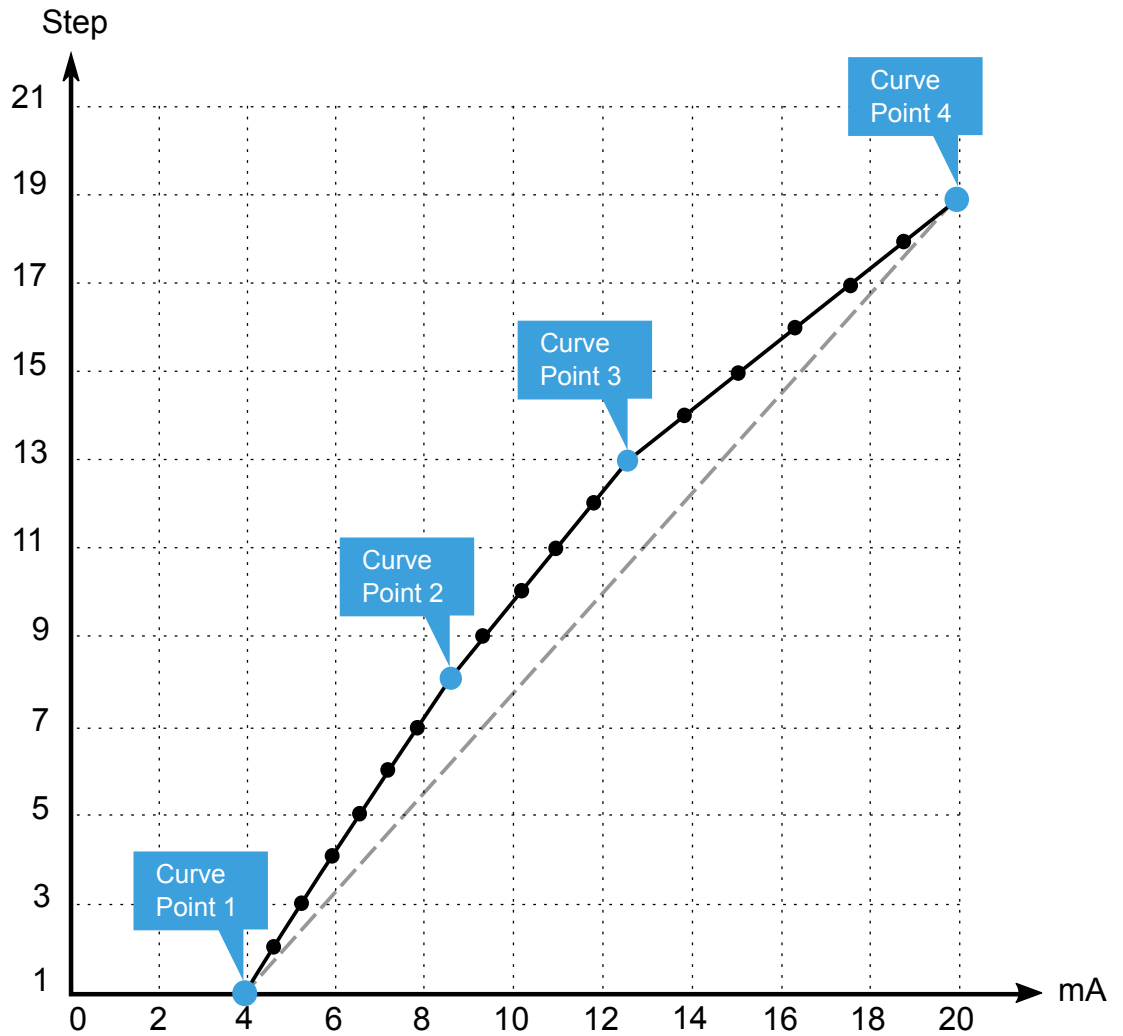

| Parameter             | Setting           |
|-----------------------|-------------------|
| Scaled value handling | Integer (nearest) |
| Input value 1         | 4                 |
| Scaled output value 1 | 1                 |
| Input value 2         | 8.5               |
| Scaled output value 2 | 8                 |
| Add curve point 3     | Used              |
| Input value 3         | 12.5              |
| Scaled output value 3 | 13                |
| Add curve point 4     | Used              |
| Input value 4         | 20                |

| Parameter             | Setting |
|-----------------------|---------|
| Scaled output value 4 | 19      |

External mA input

There is an alternative to using an RTD & mA card: one can also use an external mA unit (ADAM-4016) which connects to the RS-485 port.

Binary coded inputs

Sometimes tap position indication is done by using multiple digital inputs. With binary coded inputs any one decimal numeral can be represented by a six-bit pattern. You can use binary input code by setting the "Tap position indication" to "Binary coded inputs" at the Tap settings. The digital inputs are then defined in the regulator's menu at *Control* → *Control functions* → *Voltage regulator* → *IO* → *Input signal control*. Up to six digital inputs can be set for binary input coding, and up to 63 positions can be indicated with binary coding (see the image below).

| Binary coded input | Bits |   |   |   |   |   | Decimal digit |
|--------------------|------|---|---|---|---|---|---------------|
|                    | 6    | 5 | 4 | 3 | 2 | 1 |               |
|                    | 0    | 0 | 0 | 0 | 0 | 0 | 0             |
|                    | 0    | 0 | 0 | 0 | 0 | 1 | 1             |
|                    | 0    | 0 | 0 | 0 | 1 | 0 | 2             |
|                    | 0    | 0 | 0 | 0 | 1 | 1 | 3             |
|                    | 0    | 0 | 0 | 1 | 0 | 0 | 4             |
|                    | 0    | 0 | 0 | 1 | 0 | 1 | 5             |
|                    | 0    | 0 | 0 | 1 | 1 | 0 | 6             |
|                    | 0    | 0 | 0 | 1 | 1 | 1 | 7             |
|                    | 0    | 0 | 1 | 0 | 0 | 0 | 8             |
|                    | 0    | 0 | 1 | 0 | 0 | 1 | 9             |
|                    | 0    | 0 | 1 | 0 | 1 | 0 | 10            |
|                    | 0    | 0 | 1 | 0 | 1 | 1 | 11            |
|                    | 0    | 0 | 1 | 1 | 0 | 0 | 12            |
|                    | 0    | 0 | 1 | 1 | 0 | 1 | 13            |
|                    | 0    | 0 | 1 | 1 | 1 | 0 | 14            |
|                    | 0    | 0 | 1 | 1 | 1 | 1 | 15            |
|                    | 0    | 1 | 0 | 0 | 0 | 0 | 16            |
|                    | 0    | 1 | 0 | 0 | 0 | 1 | 17            |
|                    | 0    | 1 | 0 | 0 | 1 | 0 | 18            |
|                    | 0    | 1 | 0 | 0 | 1 | 1 | 19            |
|                    | 0    | 1 | 0 | 1 | 0 | 0 | 20            |
|                    | 0    | 1 | 0 | 1 | 0 | 1 | 21            |
|                    | 0    | 1 | 0 | 1 | 1 | 0 | 22            |
|                    | 0    | 1 | 0 | 1 | 1 | 1 | 23            |
|                    | 0    | 1 | 1 | 0 | 0 | 0 | 24            |
|                    | 0    | 1 | 1 | 0 | 0 | 1 | 25            |
|                    | 0    | 1 | 1 | 0 | 1 | 0 | 26            |
|                    | 0    | 1 | 1 | 0 | 1 | 1 | 27            |
|                    | 0    | 1 | 1 | 1 | 0 | 0 | 28            |
|                    | 0    | 1 | 1 | 1 | 0 | 1 | 29            |
|                    | 0    | 1 | 1 | 1 | 1 | 0 | 30            |
|                    | 0    | 1 | 1 | 1 | 1 | 1 | 31            |
|                    | 1    | 0 | 0 | 0 | 0 | 0 | 32            |
|                    | 1    | 0 | 0 | 0 | 0 | 1 | 33            |
|                    | 1    | 0 | 0 | 0 | 1 | 0 | 34            |
|                    | 1    | 0 | 0 | 0 | 1 | 1 | 35            |
|                    | 1    | 0 | 0 | 1 | 0 | 0 | 36            |
|                    | 1    | 0 | 0 | 1 | 0 | 1 | 37            |
|                    | 1    | 0 | 0 | 1 | 1 | 0 | 38            |
|                    | 1    | 0 | 0 | 1 | 1 | 1 | 39            |
|                    | 1    | 0 | 1 | 0 | 0 | 0 | 40            |
|                    | 1    | 0 | 1 | 0 | 0 | 1 | 41            |
|                    | 1    | 0 | 1 | 0 | 1 | 0 | 42            |
|                    | 1    | 0 | 1 | 0 | 1 | 1 | 43            |
|                    | 1    | 0 | 1 | 1 | 0 | 0 | 44            |
|                    | 1    | 0 | 1 | 1 | 0 | 1 | 45            |
|                    | 1    | 0 | 1 | 1 | 1 | 0 | 46            |
|                    | 1    | 0 | 1 | 1 | 1 | 1 | 47            |
|                    | 1    | 1 | 0 | 0 | 0 | 0 | 48            |
|                    | 1    | 1 | 0 | 0 | 0 | 1 | 49            |
|                    | 1    | 1 | 0 | 0 | 1 | 0 | 50            |
|                    | 1    | 1 | 0 | 0 | 1 | 1 | 51            |
|                    | 1    | 1 | 0 | 1 | 0 | 0 | 52            |
|                    | 1    | 1 | 0 | 1 | 0 | 1 | 53            |
|                    | 1    | 1 | 0 | 1 | 1 | 0 | 54            |
|                    | 1    | 1 | 0 | 1 | 1 | 1 | 55            |
|                    | 1    | 1 | 1 | 0 | 0 | 0 | 56            |
|                    | 1    | 1 | 1 | 0 | 0 | 1 | 57            |
|                    | 1    | 1 | 1 | 0 | 1 | 0 | 58            |
|                    | 1    | 1 | 1 | 0 | 1 | 1 | 59            |
|                    | 1    | 1 | 1 | 1 | 0 | 0 | 60            |
|                    | 1    | 1 | 1 | 1 | 0 | 1 | 61            |
|                    | 1    | 1 | 1 | 1 | 1 | 0 | 62            |
|                    | 1    | 1 | 1 | 1 | 1 | 1 | 63            |

BCD-coded digital inputs

Just like binary coded input position indication, "Binary coded decimal" (BCD) position indication also uses multiple digital inputs. But they are not interchangeable. Difference between the two is the numbering format. Whereas binary coded mode 4-bit hexadecimal number is valid up to  $F_{16}$  representing binary  $1111_2$  (decimal 15), BCD numbers stop at decimal 9 ( $1001_2$  in binary). Because of this decimal 10 is  $1\ 0000_2$  in binary. You can use BCD inputs by setting the "Tap position indication" to "BCD-coded inputs" at the Tap settings. The digital inputs are then defined in the regulator's menu at *Control* → *Control functions* → *Voltage regulator* → *IO* → *Input signal control*. Up to five digital inputs can be set for BCD coding, and up to 39 positions can be indicated with BCD coding (see the image below).

| BCD coded input | Bits |   |   |   |   |   | Decimal digit |
|-----------------|------|---|---|---|---|---|---------------|
|                 | 6    | 5 | 4 | 3 | 2 | 1 |               |
| 0 0 0 0 0 0     | 0    | 0 | 0 | 0 | 0 | 0 | 0             |
| 0 0 0 0 0 1     | 0    | 0 | 0 | 0 | 0 | 1 | 1             |
| 0 0 0 0 1 0     | 0    | 0 | 0 | 0 | 1 | 0 | 2             |
| 0 0 0 0 1 1     | 0    | 0 | 0 | 0 | 1 | 1 | 3             |
| 0 0 0 1 0 0     | 0    | 0 | 0 | 1 | 0 | 0 | 4             |
| 0 0 0 1 0 1     | 0    | 0 | 0 | 1 | 0 | 1 | 5             |
| 0 0 0 1 1 0     | 0    | 0 | 0 | 1 | 1 | 0 | 6             |
| 0 0 0 1 1 1     | 0    | 0 | 0 | 1 | 1 | 1 | 7             |
| 0 0 1 0 0 0     | 0    | 0 | 1 | 0 | 0 | 0 | 8             |
| 0 0 1 0 0 1     | 0    | 0 | 1 | 0 | 0 | 1 | 9             |
| 0 0 1 0 1 0     | 0    | 0 | 1 | 0 | 1 | 0 | 10            |
| 0 0 1 0 1 1     | 0    | 0 | 1 | 0 | 1 | 1 | 11            |
| 0 0 1 1 0 0     | 0    | 0 | 1 | 1 | 0 | 0 | 12            |
| 0 0 1 1 0 1     | 0    | 0 | 1 | 1 | 0 | 1 | 13            |
| 0 0 1 1 1 0     | 0    | 0 | 1 | 1 | 1 | 0 | 14            |
| 0 0 1 1 1 1     | 0    | 0 | 1 | 1 | 1 | 1 | 15            |
| 0 1 0 0 0 0     | 0    | 1 | 0 | 0 | 0 | 0 | 16            |
| 0 1 0 0 0 1     | 0    | 1 | 0 | 0 | 0 | 1 | 17            |
| 0 1 0 0 1 0     | 0    | 1 | 0 | 0 | 1 | 0 | 18            |
| 0 1 0 0 1 1     | 0    | 1 | 0 | 0 | 1 | 1 | 19            |

| BCD coded input | Bits |   |   |   |   |   | Decimal digit |
|-----------------|------|---|---|---|---|---|---------------|
|                 | 6    | 5 | 4 | 3 | 2 | 1 |               |
| 0 1 0 1 0 0     | 0    | 1 | 0 | 1 | 0 | 0 | 20            |
| 0 1 0 1 0 1     | 0    | 1 | 0 | 1 | 0 | 1 | 21            |
| 0 1 0 1 1 0     | 0    | 1 | 0 | 1 | 1 | 0 | 22            |
| 0 1 0 1 1 1     | 0    | 1 | 0 | 1 | 1 | 1 | 23            |
| 0 1 1 0 0 0     | 0    | 1 | 1 | 0 | 0 | 0 | 24            |
| 0 1 1 0 0 1     | 0    | 1 | 1 | 0 | 0 | 1 | 25            |
| 0 1 1 0 1 0     | 0    | 1 | 1 | 0 | 1 | 0 | 26            |
| 0 1 1 0 1 1     | 0    | 1 | 1 | 0 | 1 | 1 | 27            |
| 0 1 1 1 0 0     | 0    | 1 | 1 | 1 | 0 | 0 | 28            |
| 0 1 1 1 0 1     | 0    | 1 | 1 | 1 | 0 | 1 | 29            |
| 0 1 1 1 1 0     | 0    | 1 | 1 | 1 | 1 | 0 | 30            |
| 0 1 1 1 1 1     | 0    | 1 | 1 | 1 | 1 | 1 | 31            |
| 1 0 0 0 0 0     | 1    | 0 | 0 | 0 | 0 | 0 | 32            |
| 1 0 0 0 0 1     | 1    | 0 | 0 | 0 | 0 | 1 | 33            |
| 1 0 0 0 1 0     | 1    | 0 | 0 | 0 | 1 | 0 | 34            |
| 1 0 0 0 1 1     | 1    | 0 | 0 | 0 | 1 | 1 | 35            |
| 1 0 0 1 0 0     | 1    | 0 | 0 | 1 | 0 | 0 | 36            |
| 1 0 0 1 0 1     | 1    | 0 | 0 | 1 | 0 | 1 | 37            |
| 1 0 0 1 1 0     | 1    | 0 | 0 | 1 | 1 | 0 | 38            |
| 1 0 0 1 1 1     | 1    | 0 | 0 | 1 | 1 | 1 | 39            |

Tap position measured from resistance

Instead of mA measurement, RTD resistance is also an applicable option. To use RTD measurement the position indication needs to be scaled in *Measurement* → *AI (mA, DI volt) scaling* (see the image below).

| Parameter             | Setting           |
|-----------------------|-------------------|
| Scaled value handling | Integer (nearest) |
| Input value 1         | 4                 |
| Scaled output value 1 | 1                 |
| Input value 2         | 8.5               |
| Scaled output value 2 | 8                 |
| Add curve point 3     | Used              |
| Input value 3         | 12.5              |
| Scaled output value 3 | 13                |
| Add curve point 4     | Used              |

| Parameter             | Setting |
|-----------------------|---------|
| Input value 4         | 20      |
| Scaled output value 4 | 19      |

In the example figure above, the RTD card's Sensor 1 is used for tap position indication. With these settings the measured resistance (0...180  $\Omega$ ) is transferred to the tap position 1...19. To use this scaling setting, please select the option "Scaled input" for the "Tap position status" parameter.

#### Tap position measured from digital input voltage

If none of the above possibilities (RTD, mA, binary coding or BCD coding) are available, it is also possible to use a digital input channel to measure the voltage over the tap changer through a resistor and then use this to indicate the tap changer position. The setup procedure is nearly identical to the RTD measurement option setup (as described above), except the desired digital input voltage is selected as the tap position source.

#### Voltage regulation settings ("Active settings")

The settings presented in this subsection can be changed online by changing the setting group.

The target voltage and the control window where the voltage should be kept need to be set for the regulator in percentage of the nominal value. When setting up the parameters for the voltage window one should consider the regulating sensitivity and the minimizing of control operations. An unnecessarily tight voltage window may cause excessive control operations which in turn cause the network voltage to fluctuate. The target should be a calm network that only causes necessary control operations. A correctly set voltage window is kind to the physical tap changer and keeps the network voltage stable during normal network events.

There are a few basic rules that apply to the setting of the parameters for the first voltage window. First, the window should never be set below the value of the tap step effect setting, and the window should never exceed the allowed variation loads.

Therefore, the minimum voltage window size can be calculated as follows:

$$U_{>/<window} = 1.2 \times \text{tap step effect \%}$$

This gives 20 % more total band for regulating, and this setting ensures that the voltage remains within the voltage window after a tap change operation. You can increase the regulating sensitivity by setting a smaller window; however, this is not advised.

Next, the window must be set into the voltage regulator: divide the calculated  $U_{>/<window}$  by two, and then set the result as the value for the parameters  $U_{>}$  setting ( $+U_{TGT}$ ) and  $U_{<}$  setting ( $-U_{TGT}$ ). If the values for both window settings are equal, the regulator has same sensitivity for both overvoltage and undervoltage situations. The voltage windows as well as all other setting parameters are in relation to the set target voltage  $U_{TGT}$ . If the target voltage is changed, the voltage window setting parameters change as well to follow the new target voltage.

The following three images present various situations with the setting of the voltage window.

Figure. 4.5.2 - 123. Tight voltage window (window not reached).

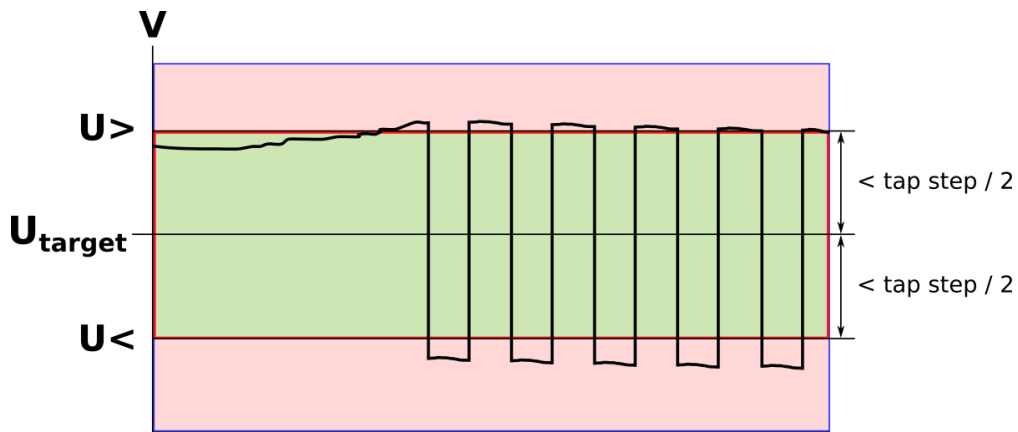

In this example situation the set voltage window is too tight compared to the tap effect. The AVR cannot reach the target window and thus lowers the voltage. Eventually a stable voltage may be found but the next tap change request will cause similar fluctuation and the cycle begins again.

Figure. 4.5.2 - 124. Tight voltage window (window reached but voltage near the limit).

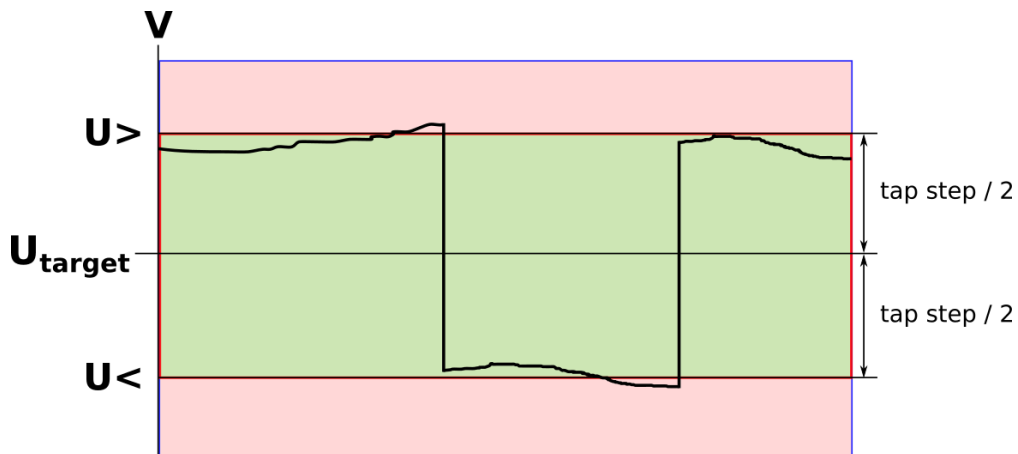

In this example situation the set voltage window is still too tight compared to the tap effect. This time the AVR reaches the target window with one tap change, but afterwards the voltage is very close to the limit. If the voltage goes back to the original value, another tap change is needed. This may cause an excessive number of tap operations, and the quality of the network voltage is not significantly improved.

Figure. 4.5.2 - 125. Voltage window according to the recommendation.

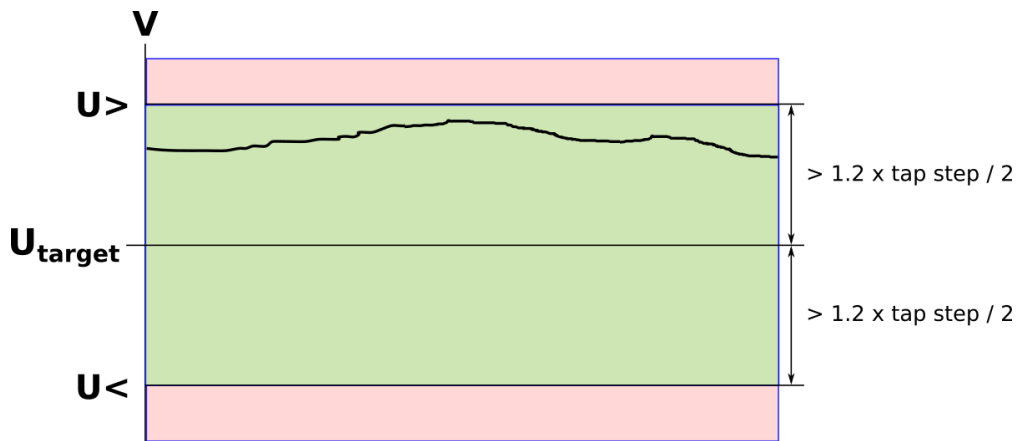

In this example the voltage window limits are set according to the recommendation: the set window is 20 % bigger than the tap step effect. This ensures that after tap changing the voltage it's not too near the opposite voltage window limit. If the user wants more sensitivity, the voltage window can be set lower; however, it is not recommended that the set window is less than 5 % bigger than the tap step effect.

In automatic voltage regulator applications the first window ( $U>/<_{window}$ ) is usually used for slower operation with a definite set operating time and small deviations. Typically this operating time is 30...120 seconds. The function starts counting the operating time when the measured voltage exceeds either of the set window limits. If the voltage remains beyond the limits until the set operating time has passed, a tap change operation is applied. If the measured voltage returns to within the target voltage window, the operating time counter is reset. A 3 % hysteresis is applied for the U> and U< pick-up resets in the voltage window.

When defining the setting limits for the second (fast operation) voltage window, it must be ensured that one tap change cannot bring the voltage within the first voltage window. See the image below, where the first window is 20 % bigger than the tap step effect and the second window is increased by two tap steps from the first window. When the voltage exceeds the higher limit of the second voltage window, one tap change operation is applied and it brings the voltage down. However, the voltage stays within the second window limits. Only when a second tap change is applied does the voltage drop within the limits of the first voltage window.

Figure. 4.5.2 - 126. Second voltage window two tap steps from the first voltage window.

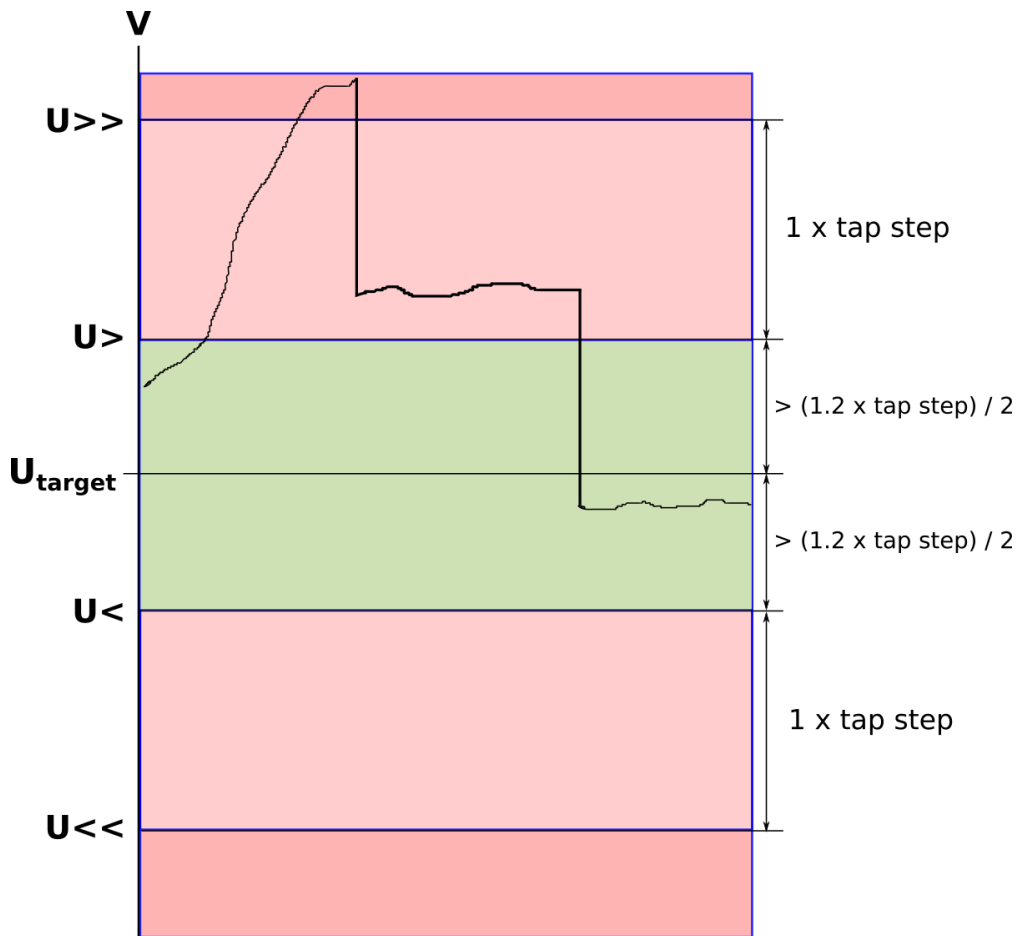

It is recommended that the operating time for the second (fast) window is in inverse mode, although it can also be set to the definite operating mode. Therefore, the more the measured voltage exceeds the threshold, the faster the operating time will be.

The AVR inverse operating time is calculated with the following equation:

$$\text{Operating time} = \frac{U_{>>/<<} \text{ time delay} * \text{Tap effect}\%}{|\Delta U\%|}$$

For example, if  $U_{>>/<<} \text{ time delay}$  has been set to 40 seconds and the measured voltage difference from the set target is 4 %, using the formula above the operating time can be determined to be 10 seconds (40s / 4)

Figure. 4.5.2 - 127. Inverse operating time characteristics for the second voltage window ( $U > > / < < \text{window}$ ).

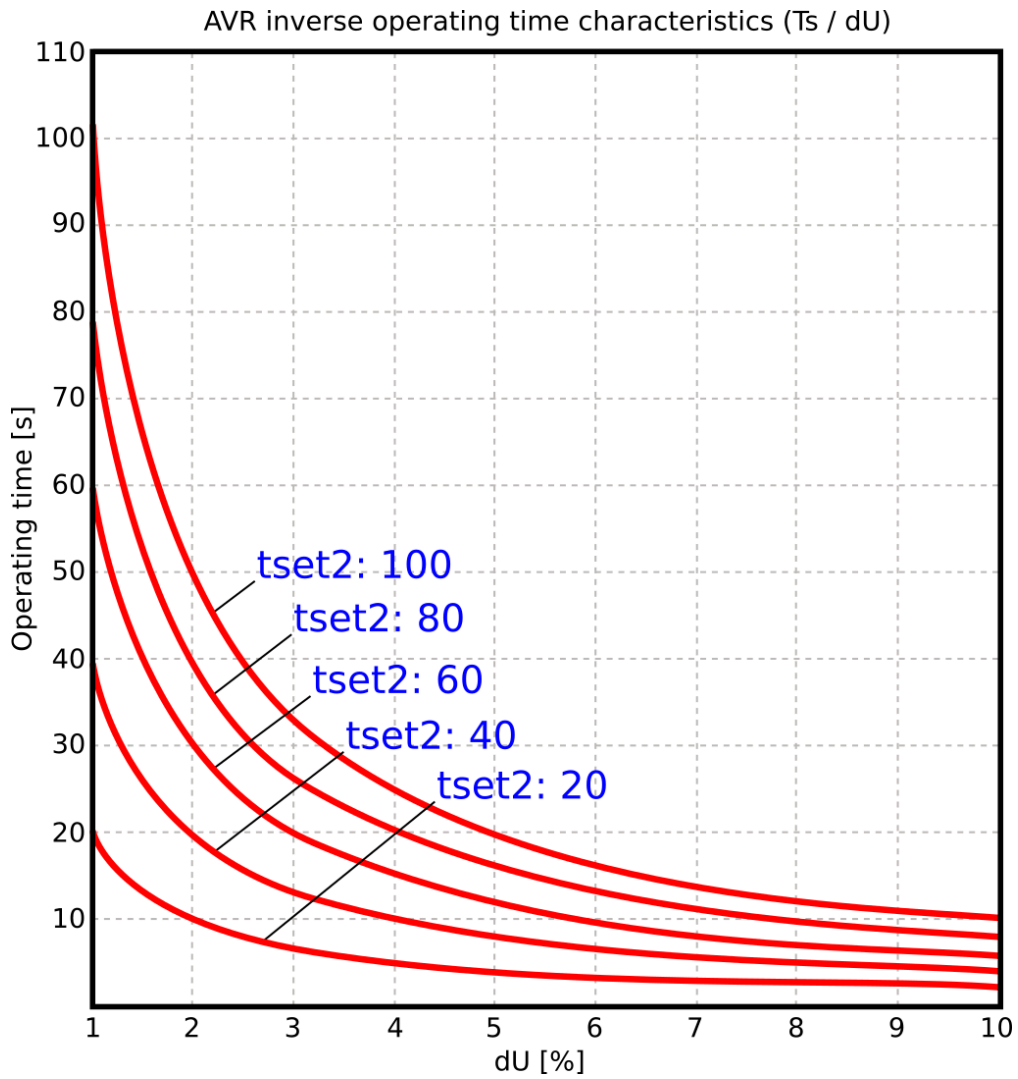

The inverse operating time controls the voltage back to the set target window: the bigger the deviation ( $dU$  [%]) is, the smaller the operating time to get the voltage within the target window.

Figure. 4.5.2 - 128. Combined operating time characteristics of both voltage windows.

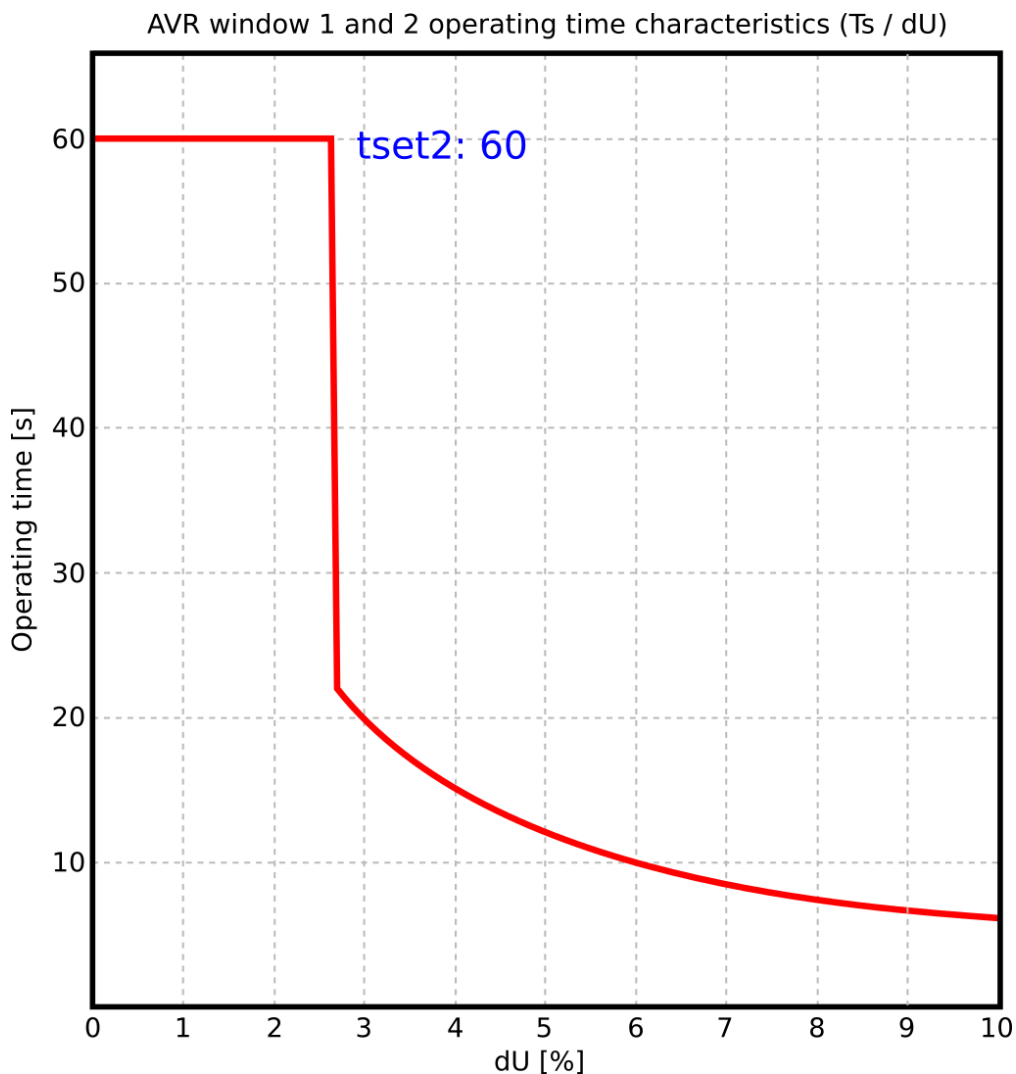

The figure above presents the combined operating time characteristics of both voltage windows as a function of the voltage deviation. As it shows, the faster inverse operation time characteristics are in effect until the voltage deviation hits the  $U >> / <<$  window threshold. After hitting the  $U > / <$  window threshold the graph follows the definite operating time characteristics.

Settings for this example are:

$$U > / < \text{ pick-up} = \frac{(1.2 \times \text{tap step effect})}{2} = \frac{(1.2 \times 1.67\%)}{2} \approx 1\%$$

→ operating time is 60 seconds

$$U >> / << \text{ pick-up} = U > / < \text{ pick-up} + \text{tap step effect} = 1\% + 1.67\% \approx 2.67\%$$

→ operating time is 60 seconds

When a very high overvoltage occurs, the regulator instantly lowers the voltage without any other delays but the given minimum time between control pulses. This lowering function remains in use until the measured voltage is below the set instant low threshold level ( $U >>>$  Instant setting). After this level is reached, the time characteristics of the corresponding window calculate the consecutive time delays until the desired target window is reached.

Figure. 4.5.2 - 129. Instant low command with two time-delayed windows.

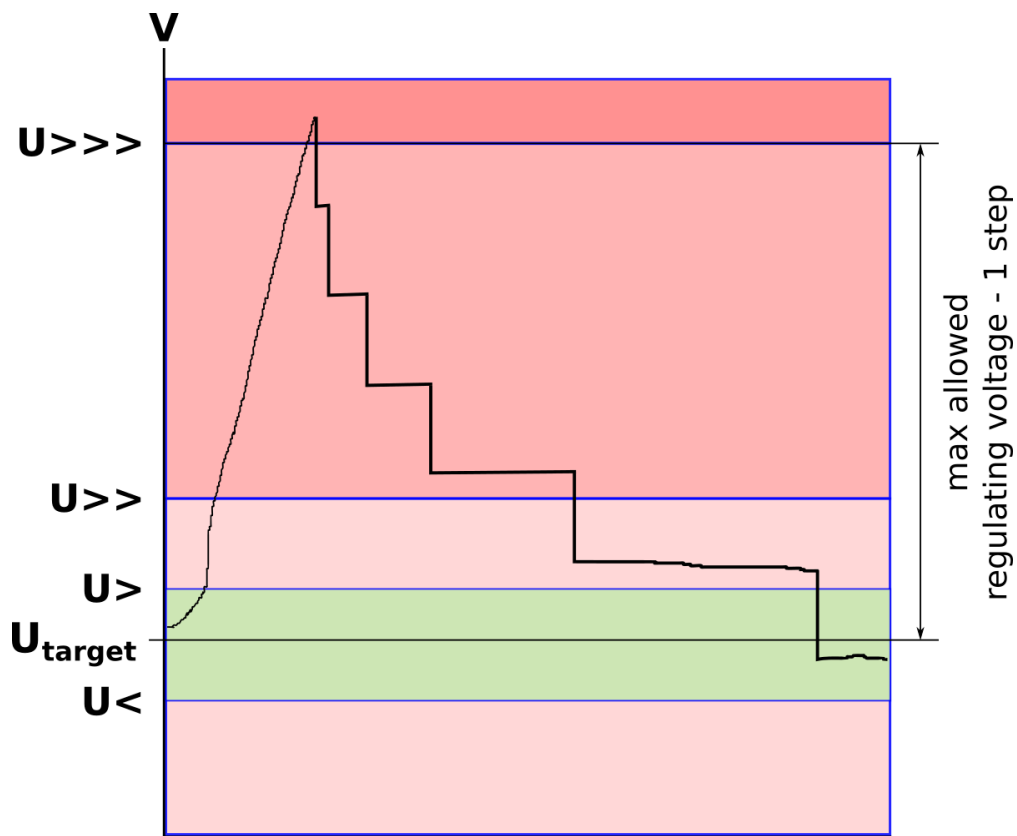

The pick-up setting recommendation for the instant low function is equal to the the maximum allowed overvoltage subtracted by the tap effect. This way there should not be situations where the voltage is allowed to stay above the maximum allowed voltage for a long time. For example, if the maximum allowed overvoltage is 10 % by local standards and the tap effect for the transformer is 1.67 %, the pick-up for the instant low function should be set to 8.33 % (10 % – 1.67 %).

Figure. 4.5.2 - 130. Effect of the Instant low setting on time characteristics.

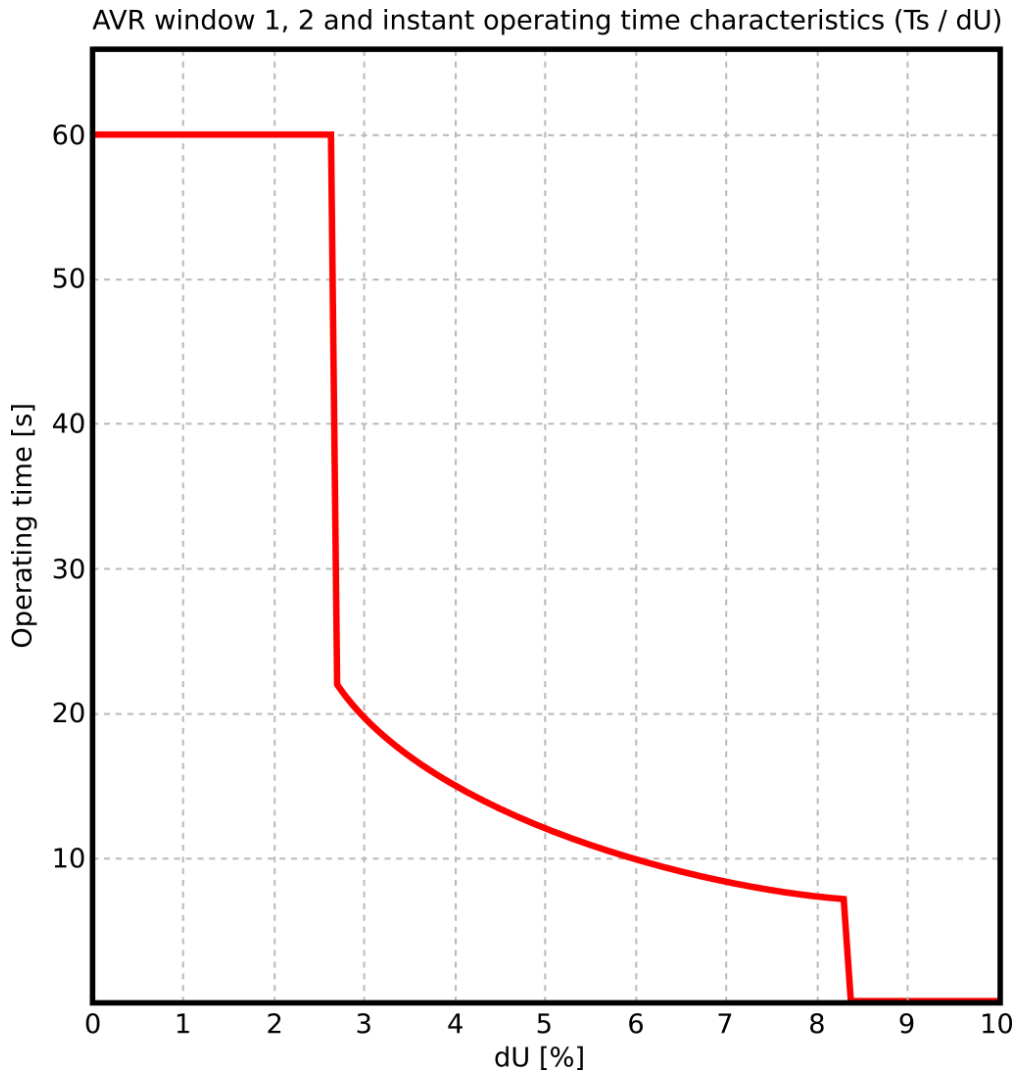

The AVR's low voltage blocking prevents the tap changer's operations to avoid the control to the maximum position when the feeding voltage returns to the nominal level (see the image below). This can occur in various power-off situations, such as when there is a heavy short-circuit fault in the feeding network side, or when the tap drifts towards the maximum voltage.

Figure. 4.5.2 - 131. Low voltage blocking.

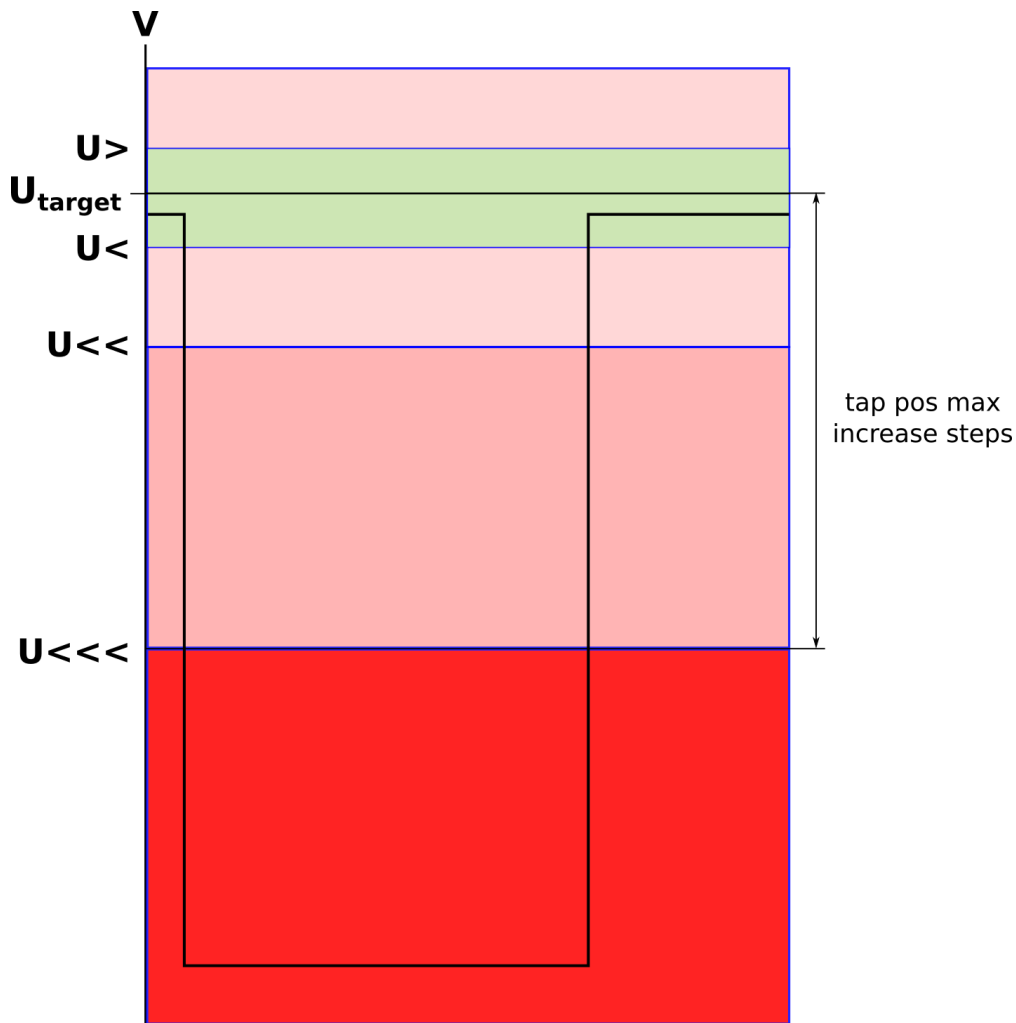

The recommended setting for low voltage blocking is the maximum tap increase positions effect. For example, if the tap changer has a  $\pm 9 \times 1.67\%$  control range, the undervoltage blocking should be set to  $15\%$  ( $9 \times 1.67\%$ ).

The last part of the AVR configuration is to make sure that an overcurrent or a short-circuit fault on the load side does not cause a tap change operation due to the load-side voltage drop. If the regulator's operation is not blocked during the short-circuit fault when the transformer is under heavy overcurrent, the tap changer controls the voltage up to compensate for the voltage drop; this most probably ends up causing damage to the tap changer equipment. However, the blocking can also be achieved by internal overcurrent blocking (if the phase currents are measured with the AVR) or by a pick-up signal from the external overcurrent protection device or transformer protection device (GOOSE or a wired signal to the AVR's digital input).

### Measured input

The AVR measures fundamental frequency component of phase-to-phase voltages for supervising the voltage level. Fundamental frequency component of phase currents can be used for overcurrent blocking.

Table. 4.5.2 - 233. Measurement inputs of the automatic voltage regulator function.

| Signal              | Description  |
|---------------------|--|
| U <sub>1</sub> RMS  | Fundamental frequency component of voltage channel U <sub>1</sub> /V |
| U <sub>2</sub> RMS  | Fundamental frequency component of voltage channel U <sub>2</sub> /V |
| U <sub>3</sub> RMS  | Fundamental frequency component of voltage channel U <sub>3</sub> /V |
| U <sub>4</sub> RMS  | Fundamental frequency component of voltage channel U <sub>4</sub> /V |
| I <sub>L1</sub> RMS | Fundamental frequency component of phase L1 (A) current              |
| I <sub>L2</sub> RMS | Fundamental frequency component of phase L2 (B) current              |
| I <sub>L3</sub> RMS | Fundamental frequency component of phase L1 (C) current              |

## General settings

The general settings define the basic control settings for the voltage measurement configuration. The settings give general information about the AV regulator's condition and status. The general settings also include indications and measurements.

Table. 4.5.2 - 234. General setting parameters.

| Name                    | Range  | Step | Default | Description  |
|-------------------------|--|------|---------|--|
| Vreg LN mode            | <ul style="list-style-type: none"> <li>On</li> <li>Blocked</li> <li>Test</li> <li>Test/Blocked</li> <li>Off</li> </ul>   | -    | On      | Set mode of VRG block.<br>This parameter is visible only when <i>Allow setting of individual LN mode</i> is enabled in <i>General</i> menu.          |
| Vreg LN behaviour       | <ul style="list-style-type: none"> <li>On</li> <li>Blocked</li> <li>Test</li> <li>Test/Blocked</li> <li>Off</li> </ul>   | -    | -       | Displays the mode of VRG block.<br>This parameter is visible only when <i>Allow setting of individual LN mode</i> is enabled in <i>General</i> menu. |
| Vreg settings condition | <ul style="list-style-type: none"> <li>U&gt;&gt; set too low</li> <li>U&lt; set too high</li> <li>U&gt; set higher than U&gt;&gt;</li> <li>U&lt; set lower than U&lt;&lt;</li> <li>U&gt;&gt;&gt; set too low</li> <li>U&lt;&lt;&lt; set too high</li> <li>VT selection not ok</li> </ul> | -    | -       | When opened displays the internal information about the settings. If the value differs from 0, the settings are not correct.                         |

| Name                             | Range   | Step                 | Default | Description   |
|----------------------------------|---|----------------------|---------|---|
| Vreg condition                   | <ul style="list-style-type: none"> <li>• Raise command on</li> <li>• Lower command on</li> <li>• Operation blocked</li> <li>• Output control blocked</li> <li>• U&lt;&lt;&lt; block on</li> <li>• I&gt; block on</li> <li>• Tap on highlimit</li> <li>• Tap on lowlimit</li> <li>• Operation blocked</li> <li>• U&gt;/&lt; pick-up on</li> <li>• U&gt;&gt;/&lt;&lt; pick-up on</li> <li>• Control wait time on</li> <li>• Manual control mode on</li> </ul> | -                    | -       | When opened displays the internal information about the automatic voltage regulator's current status. When the value is 0, nothing is happening.          |
| Vreg timer active                | <ul style="list-style-type: none"> <li>• -</li> <li>• Fine tune decrease</li> <li>• Fine tune increase</li> <li>• Low set decrease</li> <li>• High set decrease</li> <li>• Instant decrease</li> <li>• Low set increase</li> <li>• High set increase</li> </ul>   | -                    | -       | Displays the timer, when the AVR is counting time. Time left to operation is indicated by the "Time left to operation" parameter.                         |
| Time left to operation           | 0.000...1800.000s   | 0.005s               | -       | Displays the time the counter has left before action. The "Vreg timer active" parameter displays which timer is counting down.                            |
| Voltage now                      | 0.00...140.00%U <sub>n</sub>  | 0.01%U <sub>n</sub>  | -       | Displays the measured reference voltage.  |
| Voltage difference to set target | 0.00...140.00%U <sub>n</sub>  | 0.01%U <sub>n</sub>  | -       | Displays the difference between the measured reference voltage and the set target voltage.  |
| Voltage set now to               | -50 000...50 000V <sub>pri</sub>  | 0.01V <sub>pri</sub> | -       | Displays the primary voltage deviation. Based on the location of the tap changer. Calculation formula is "Absolute tap location" times "Tap step effect". |
| U>>> (instant) setting           | 0.00...140.00%  | 0.01%                | -       | Displays the set instant stage (compared to the nominal 100 % level).   |

| Name                          | Range   | Step  | Default | Description   |
|-------------------------------|---|-------|---------|---|
| U>> setting                   | 0.00...140.00%  | 0.01% | -       | Displays the set upper limit of the second window (compared to the nominal 100 % level).    |
| U> setting                    | 0.00...140.00%  | 0.01% | -       | Displays the set upper limit of the first window (compared to the nominal 100 % level).     |
| U< setting                    | 0.00...140.00%  | 0.01% | -       | Displays the set lower limit of the first window (compared to the nominal 100 % level).     |
| U<< setting                   | 0.00...140.00%  | 0.01% | -       | Displays the set lower limit of the second window (compared to the nominal 100 % level).    |
| U<<< (block) setting          | 0.00...140.00%  | 0.01% | -       | Displays the set undervoltage blocking limit.   |
| Voltage measurement           | <ul style="list-style-type: none"> <li>• U12</li> <li>• U23</li> <li>• U31</li> <li>• U4 input</li> </ul>   | -     | U12     | Displays the selected voltage. Please check that the selected voltage input is correct.     |
| Voltage measurement condition | <ul style="list-style-type: none"> <li>• Not configured</li> <li>• System U12</li> <li>• System U23</li> <li>• System U31</li> <li>• VT4 meas U12</li> <li>• VT4 meas U23</li> <li>• VT4 meas U31</li> <li>• VT4 conf not ok</li> </ul> | -     | -       | Displays which voltage is used by the function.   |
| Tap location (- 0 +)          | -30...30  | 1     | 0       | The tap location in the tap changer, in relation to the middle point.                       |
| Absolute tap location         | 0...50  | 1     | 0       | The tap location in the tap changer, in relation to the whole range (0...max) of tap steps. |
| Tap changer on high border    | <ul style="list-style-type: none"> <li>• No</li> <li>• Yes</li> </ul>   | -     | No      | Indicates when the tap changer has reached the maximum voltage high position.               |
| Tap changer on low border     | <ul style="list-style-type: none"> <li>• No</li> <li>• Yes</li> </ul>   | -     | No      | Indicators when the tap changer has reached the minimum voltage low position.               |

## Control settings

The control settings define the control model as well as the manual increasing and decreasing commands from the HMI. The timing controls are here as well.

Table. 4.5.2 - 235. Control settings parameters.

| Name                     | Range  | Step   | Default | Description  |
|--------------------------|--|--------|---------|--|
| Control mode             | <ul style="list-style-type: none"> <li>Auto</li> <li>Manual</li> </ul> | -      | Auto    | Displays the control mode: automatic or manual.                          |
| Max control pulse length | 0.000...1800.000s  | 0.005s | 2.000s  | Sets the maximum time the tap control's output contact can be closed.    |
| Min control pulse length | 0.000...1800.000s  | 0.005s | 2.000s  | Sets the minimum time the tap control's output contact must be closed.   |
| Min time between pulses  | 0.000...1800.000s  | 0.005s | 0.500s  | Sets the minimum time between the separate consecutive control commands. |

## Tap settings

The tap settings define the tap changer equipment properties and the connection for position indication to the regulator. The tap settings also include indicators and measurements.

Table. 4.5.2 - 236. Tap settings parameters.

| Name                            | Range  | Step | Default      | Description  |
|---------------------------------|--|------|--------------|--|
| Tap position indication         | <ul style="list-style-type: none"> <li>Select</li> <li>mA internal input 7</li> <li>mA internal input 8</li> <li>mA external input</li> <li>Scaled input</li> <li>Binary coded inputs</li> <li>mAln1 (I card 1)</li> <li>mAln2 (I card 2)</li> <li>BCD coded inputs</li> <li>mAln1 (T card 1)</li> <li>mAln2 (T card 1)</li> <li>mAln3 (T card 1)</li> <li>mAln4 (T card 1)</li> <li>mAln1 (T card 2)</li> <li>mAln2 (T card 2)</li> <li>mAln3 (T card 2)</li> <li>mAln4 (T card 2)</li> </ul> | -    | Select       | Selects the tap changer's input mode. The "mA internal input x" options are the mA inputs found in the RTD and mA input cards. The "mA external input" option is an external ADAM mA input device connected to the RS-458 port. The "Scaled input" option is an input that has been scaled at <i>Measurements</i> → <i>AI(mA, DI volt) scaling</i> . The "BCD coded inputs" and "Binary coded inputs" options refer to the digital inputs. The "mAln x" options are the mA inputs included in the mA input card. |
| Tap position indication setting | <ul style="list-style-type: none"> <li>Not selected</li> <li>Set Ok</li> <li>Wrong setting</li> <li>Meas.Quality Fault.</li> </ul>   | -    | Not selected | Displays the health of tap position status setting. Informs if the chosen measurement is not available or the quality of the measurement is not good.  |

| Name                                     | Range  | Step                 | Default              | Description  |
|--|--|----------------------|----------------------|--|
| External mA input channel                | <ul style="list-style-type: none"> <li>• CH0</li> <li>• CH1</li> <li>• CH2</li> <li>• CH3</li> <li>• CH4</li> <li>• CH5</li> <li>• CH6</li> <li>• CH7</li> </ul>   | -                    | CH0                  | Selects the external mA input channel. This setting is only visible when "mA external input" is the selected input mode. |
| Scaled input signal                      | <ul style="list-style-type: none"> <li>• Scaling curve 1 (mA)</li> <li>• Scaling curve 2 (mA)</li> <li>• Scaling curve 3 (mA)</li> <li>• Scaling curve 4 (mA)</li> <li>• Scaling curve 1 (position)</li> <li>• Scaling curve 2 (position)</li> <li>• Scaling curve 3 (position)</li> <li>• Scaling curve 4 (position)</li> </ul> | -                    | Scaling curve 1 (mA) | Selects the scaled input signal. This setting is only visible when "Scaled input" is the selected input mode.            |
| Tap position ind. setting                | <ul style="list-style-type: none"> <li>• Not selected</li> <li>• Set Ok</li> <li>• Wrong setting</li> <li>• Meas.Quality Fault.</li> </ul>   | -                    | -                    | Indicates the status of tap position indication settings. A read-only parameter.   |
| Tap total positions (absolute value 1-n) | 1...70n  | 1n                   | 18n                  | Defines the number of tap positions.   |
| Tap center (on absolute scale)           | 1...35 position  | 1 position           | 10 position          | Defines the center tap location on the absolute scale.   |
| Tap step effect                          | 0.01...10.00%  | 0.01%                | 1.67%                | Defines the effect of a step (in percentage based on the nominal voltage).   |
| Tap step voltage effect                  | 0.00...5000.00V <sub>pri</sub>   | 0.01V <sub>pri</sub> | 0V <sub>pri</sub>    | Displays the effect of one tap step on the primary voltage.  |
| Tap maximum decrease                     | -140.00...0.00%  | 0.01%                | 0%                   | Displays the maximum voltage decrease from the nominal position.   |
| Tap maximum increase                     | 0.00...140.00%   | 0.01%                | 0%                   | Displays the maximum voltage increase from the nominal position.   |
| Tap control band                         | 0.00...140.00%   | 0.01%                | 0%                   | Displays the tap changer's control band.   |

| Name                                | Range   | Step    | Default        | Description  |
|-------------------------------------|---|---------|----------------|--|
| Tap position indication             | <ul style="list-style-type: none"> <li>Max.mA.max.Pos.</li> <li>Min.mA.max.Pos</li> </ul> | -       | Max.mA.max.Pos | Selects the highest tap position, the maximum or the minimum value of mA measurement.<br>This setting is not visible when "BCD coded inputs" or "Binary coded inputs" is the selected input mode.  |
| mA input low range                  | 0.000...20.000mA  | 0.001mA | 4.000mA        | Sets the minimum tap position measurement value.<br>This setting is not visible when "BCD coded inputs" or "Binary coded inputs" is the selected input mode.   |
| mA input high range                 | 0.010...20.000mA  | 0.001mA | 20.000mA       | Sets the maximum tap position measurement value.<br>This setting is not visible when "BCD coded inputs" or "Binary coded inputs" is the selected input mode.   |
| Tap step in mA                      | 0.000...20.000mA  | 0.001mA | 0mA            | Sets the effect of one tap step on the mA measurement.<br>This setting is not visible when "BCD coded inputs" or "Binary coded inputs" is the selected input mode.   |
| mA input now (from the measurement) | 0.000...20.000mA  | 0.001mA | -              | Displays the mA input measurement value at the moment.<br>This setting is visible, when any of the mA inputs is selected.  |
| mA input now (in the set range)     | 0.000...20.000mA  | 0.001mA | -              | Displays the mA input measurement value at the moment in the location indication range. For example, if the indication range is 4...20 mA and 6 mA is measured by the chosen channel, this parameter displays "2 mA".<br>This setting is visible, when any of the mA inputs is selected. |

## Statistics

These parameters display the counters of the AVR's common operations and statuses.

Table. 4.5.2 - 237. Counters of the automatic voltage regulator function.

| Name                | Range   | Description  |
|---------------------|---|--|
| AVR raised voltage  | One tap control operation increases cumulative sum by 1 | Displays how many times the regulator has increased the bus voltage.               |
| AVR reduced voltage | One tap control operation increases cumulative sum by 1 | Displays how many times the regulator has decreased the bus voltage.               |
| AVR control blocked | One blocking operation increases cumulative sum by 1    | Displays how many times the AVR operation has been blocked by an external command. |

| Name                     | Range  | Description  |
|--------------------------|--|--|
| AVR undervoltage blocked | One blocking operation increases cumulative sum by 1                   | Displays how many times the AVR operation has been blocked by a detected undervoltage condition. |
| AVR overcurrent blocked  | One blocking operation increases cumulative sum by 1                   | Displays how many times the AVR operation has been blocked by a detected overcurrent condition.  |
| Clear statistics         | <ul style="list-style-type: none"> <li>• -</li> <li>• Clear</li> </ul> | Clears the statistics and resets the counters to zero.   |

## Active settings

These settings define the AVR's regulating behavior.

Table. 4.5.2 - 238. Active setting parameters.

| Name                  | Range   | Step                | Default               | Description   |
|-----------------------|---|---------------------|-----------------------|---|
| Voltage measurement   | <ul style="list-style-type: none"> <li>• U12</li> <li>• U23</li> <li>• U31</li> <li>• U4</li> </ul> | -                   | U12                   | Selects the measured system voltage from the UL12, UL23, UL31 and U4 inputs.  |
| Target voltage (UTGT) | 70.00...140.00%U <sub>n</sub>   | 0.01%U <sub>n</sub> | 100.00%U <sub>n</sub> | Sets the optimal regulating target voltage.   |
| U>/< window in use    | <ul style="list-style-type: none"> <li>• Not in use</li> <li>• In use</li> </ul>                    | -                   | Not in use            | Selects whether or not the low-set definite time voltage window is in use.  |
| U> setting (+UTGT)    | 0.10...30.00%U <sub>n</sub>   | 0.01%U <sub>n</sub> | 0.88%U <sub>n</sub>   | Sets the "voltage high" limit for the low-set voltage window. This setting is only visible, when the "U>/< window in use" parameter is activated.   |
| U< setting (-UTGT)    | 0.10...30.00%U <sub>n</sub>   | 0.01%U <sub>n</sub> | 0.88%U <sub>n</sub>   | Sets the "voltage low" limit for the low-set voltage window. This setting is only visible, when the "U>/< window in use" parameter is activated.  |
| U>/< time delay (DT)  | 0.000...1800.000s   | 0.005s              | 60.000s               | Sets the operating time delay before a regulating command is sent for the low-set voltage window's threshold deviation. This setting is only visible, when the "U>/< window in use" parameter is activated. |
| U>>/<< window in use  | <ul style="list-style-type: none"> <li>• Not in use</li> <li>• In use</li> </ul>                    | -                   | Not in use            | Selects whether or not the high-set definite/inverse time voltage window is in use.   |
| U>> setting (+UTGT)   | 0.10...30.00%U <sub>n</sub>   | 0.01%U <sub>n</sub> | 2.67%U <sub>n</sub>   | Sets the "voltage high" limit for the high-set voltage window. This setting is only visible, when the "U>>/<< window in use" parameter is activated.  |

| Name                               | Range  | Step                | Default              | Description  |
|------------------------------------|--|---------------------|----------------------|--|
| U<< setting (-UTGT)                | 0.10...30.00%U <sub>n</sub>  | 0.01%U <sub>n</sub> | 2.67%U <sub>n</sub>  | Sets the "voltage low" limit for the high-set voltage window.<br>This setting is only visible, when the "U>>/<< window in use" parameter is activated.   |
| U>>/<< time delay mode             | <ul style="list-style-type: none"> <li>Definite</li> <li>Integral</li> </ul> | -                   | Integral             | Selects the time delay mode for the high-set voltage window.   |
| U>>/<< time delay (DT/ Multiplier) | 0.000...1800.000s  | 0.005s              | 60.000s              | Sets the operating time delay before a regulating command is sent for the high-set voltage window's threshold deviation.<br>If the "Definite" time delay mode is selected, this value is equal to the set delay time. If the "Integral" time delay mode is selected, this setting is the inverse operating time multiplier.<br>This setting is only visible, when the "U>>/<< window in use" parameter is activated. |
| U>>> instant in use                | <ul style="list-style-type: none"> <li>Not in use</li> <li>In use</li> </ul> | -                   | Not in use           | Selects whether or not the instant low stage is in use.  |
| U>>> setting (+UTGT)               | 0.10...30.00%U <sub>n</sub>  | 0.01%U <sub>n</sub> | 8.33%U <sub>n</sub>  | Sets the overvoltage threshold for the U>>> instant low stage.<br>This setting is only visible, when the "U>>> instant in use" parameter is activated.   |
| U<<< block setting (-UTGT)         | 0.00...80.00%U <sub>n</sub>  | 0.01%U <sub>n</sub> | 15.00%U <sub>n</sub> | Sets the undervoltage blocking threshold. When measured voltage is under this level, tap control is blocked.   |
| Internal OC blocking               | <ul style="list-style-type: none"> <li>Not in use</li> <li>In use</li> </ul> | -                   | Not in use           | Selects whether or not the internal overcurrent detection blocks the AVR operation.  |
| Internal OC pick-up >              | 0.00...40.00×I <sub>n</sub>  | 0.01×I <sub>n</sub> | 2.00×I <sub>n</sub>  | Sets the pick-up threshold for the internal overcurrent blocking.<br>This setting is only visible, when the "Internal OC blocking" is activated.   |

## External blocking

The operation of the automatic voltage regulator can be blocked by either internal or external input commands. If the operation needs to be blocked externally, it can be done with digital inputs, logical signals or GOOSE messages. The AVR function provides two separate inputs for blocking. The first blocking input blocks the control algorithm's operation and the output contacts. This type of blocking is intended to be used for blocking tap changer that is in active use. The second one only blocks the output contacts while the control algorithm is still operational. This type of blocking can be used to test the operation of algorithm and event recording without physically controlling the tap changer.

Table. 4.5.2 - 239. Blocking inputs.

| Name                  | Description  |
|-----------------------|--|
| AVR Block op and outs | The application block for the AVR function. This block should be used for all external blockings of the AVR operation. Blocks the output contacts and prevents the algorithm from operating. |

| Name                   | Description   |
|------------------------|---|
| AVR block control outs | The commissioning block for the actual controlling of the output contacts. Blocks only the output contacts of the AVR function. |

## Output signals

The AVR function has the following available output signals.

Table. 4.5.2 - 240. Output signals.

| Name                  | Description   |
|-----------------------|---|
| AVR raise tap CMD     | The output command to raise the tap by one step.  |
| AVR lower tap CMD     | The output command to lower the tap by one step.  |
| AVR in manual control | Indicates that the automatic voltage regulation mode is overridden by a manual control.   |
| AVR U>/< started      | Indicates that the threshold of the first voltage window has been exceeded, and that the AVR is counting time towards the tap change operation.     |
| AVR U>>/<< started    | Indicates that the threshold of the second voltage window has been exceeded, and that the AVR is counting time towards the tap change operation.    |
| AVR outputs blocked   | Indicates that the output contact control is blocked, and that the actual output signals and events are not given to the tap changer.               |
| AVR operation blocked | Indicates that the AVR algorithms and measurements are blocked.   |
| AVR control wait on   | Indicates that the time delay of the AVR's consecutive controls is activated. Further output commands are suppressed until this signal is released. |
| AVR U< block active   | Indicates that the internal undervoltage blocking of the tap change operation is active.  |
| AVR I> block active   | Indicates that the internal overcurrent blocking of the tap change operation is active.   |
| AVR tap in highlimit  | Indicates that no further voltage increase commands can be given because the tap changer is on the high limit.                                      |
| AVR tap in lowlimit   | Indicates that no further voltage decrease commands can be given because the tap changer is on the low limit.                                       |

## Switching between automatic and manual control modes remotely and locally

If the user wants to switch between the manual and automatic control modes remotely and locally, the most practical way to do it is to use a logical input. Connect the logical input of your choice at *Control* → *Control functions* → *Voltage regulator* → *I/O* → *Input signal control* → "AVR to manual control". After the input has been set and the logic has been loaded to the device, the user can switch between manual and automatic control modes through a SCADA connection. If the user requires local control for the mode switching, one needs to set a virtual button in the mimic to control the chosen logical input. In the mimic editor (*Tools* → *Mimic editor*) set an item in the mimic and click the button "From library", and then select one of the control button icons. Next, choose which logical input this button controls, and make sure that the two images in the item are following the status of the correct logical input (see the image below).

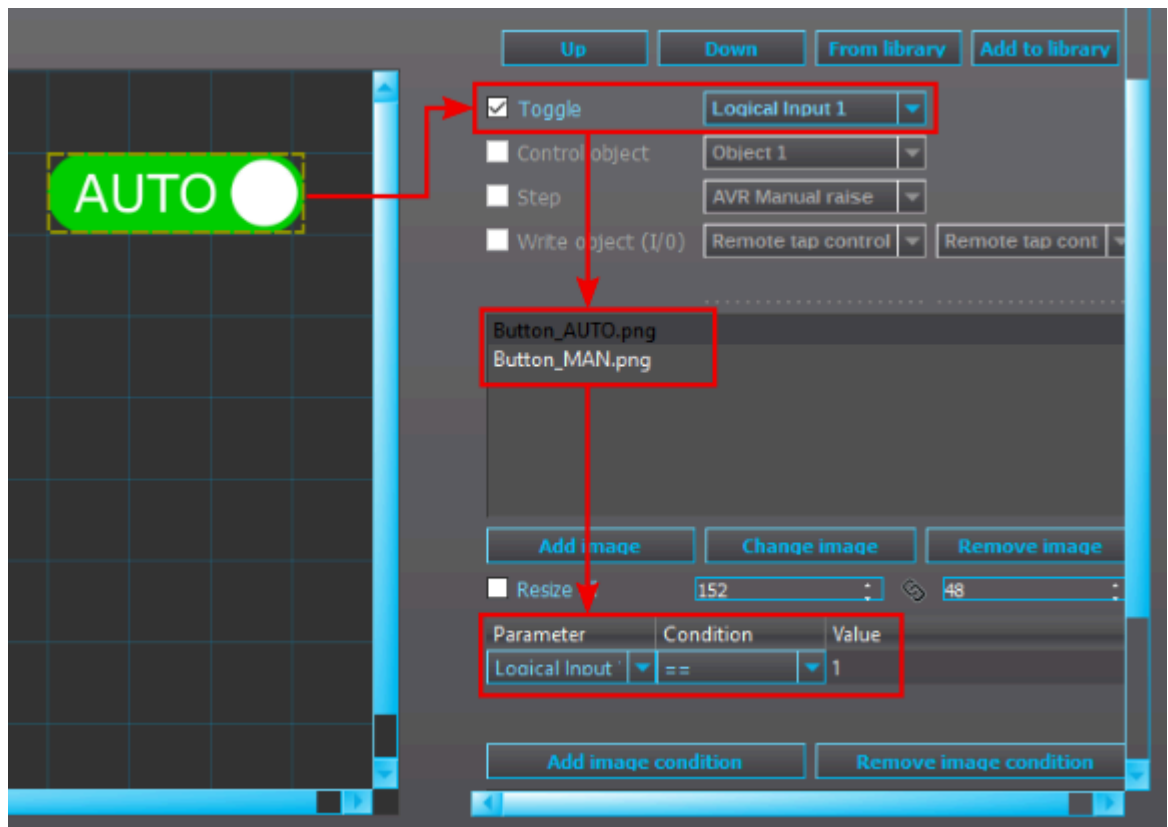

When the mimic is loaded to the device, this virtual button can be controlled in through the device HMI panel: choose it with the **Ctrl** button and then use the **I** and **O** buttons to activate the manual and automatic modes.

## Controlling the tap changer in manual mode with User-buttons

The twelve function buttons next to display can be used to manually control the tap changer. To do this, simply set the desired push buttons at *Control* → *Control Functions* → *Voltage regulator* → *I/O* → *Input Signal Control* → "AVR Manual raise" or "AVR Manual lower". Please make sure that the chosen push buttons are in the Press release mode (*Control* → *User-button Settings* → *User-button Description Settings*). Please note that unit has to be in the manual mode for these button presses to take effect.

### WARNING!



It is not recommended to connect push buttons directly to the tap changer's raising and lowering output contacts at *Control* → *Device IO* → *Device IO matrix*. If they are, the device is not capable of prohibiting manual control when the voltage regulator function is in the automatic mode.

## Controlling the voltage regulator remotely with IEC 61850

The automatic voltage regulator can also be controlled both locally and remotely with the IEC 61850 communication protocol. This requires that the voltage regulator is added to a dataset. Then the regulator can be controlled at *VRG AVCO/TapChg/Oper.* where "0" means "Stop", "1" means "Raise", and "2" means "Lower".

## Events and registers

The automatic voltage regulator function (abbreviated "VRG" in event block names) generates events and registers from the status changes in the events listed below. The user can select which event messages are stored in the main event buffer: ON, OFF, or both. The events triggered by the function are recorded with a time stamp.

Table. 4.5.2 - 241. Event messages.

| Event block name | Description                           |
|------------------|---------------------------------------|
| VRG1             | Tap Raise command ON/OFF              |
| VRG1             | Tap Lower command ON/OFF              |
| VRG1             | Block operation ON/OFF                |
| VRG1             | Block Output commands ON/OFF          |
| VRG1             | Low voltage blocking ON/OFF           |
| VRG1             | Overcurrent blocking ON/OFF           |
| VRG1             | Tap on highlimit ON/OFF               |
| VRG1             | Tap on lowlimit ON/OFF                |
| VRG1             | Operation blocked ON/OFF              |
| VRG1             | U>/< Start ON/OFF                     |
| VRG1             | U>>/<< Start ON/OFF                   |
| VRG1             | Control wait time ON/OFF              |
| VRG1             | Manual control mode                   |
| VRG1             | Automatic control mode                |
| VRG1             | Tap raise request ON/OFF              |
| VRG1             | Tap lower request ON/OFF              |
| VRG1             | Tap control circuit failure ON/OFF    |
| VRG1             | Tap difference failure ON/OFF         |
| VRG1             | Parallel communication failure ON/OFF |
| VRG1             | Transformer independent control mode  |
| VRG1             | Transformer parallel control mode     |
| VRG1             | Transformer operates as Master        |

|      |                                   |
|------|-----------------------------------|
| VRG1 | Transformer operates as Follower  |
| VRG1 | Circulating reactive current mode |
| VRG1 | Master and follower mode          |

The function registers its operation into the last twelve (12) time-stamped registers; this information is available for all provided instances separately. The register of the function records the ON event process data for Tap raise/lower, low voltage blocking, overcurrent blocking and other events. The table below presents the structure of the function's register content.

Table. 4.5.2 - 242. Register content.

| Register             | Description  |
|----------------------|--|
| Date and time        | dd.mm.yyyy hh:mm:ss.mss  |
| Event                | Event name   |
| Voltage now          | Voltage at the moment of event   |
| Tap now              | Target voltage   |
| Target volt          | Target voltage   |
| Control mode         | <ul style="list-style-type: none"> <li>• Auto</li> <li>• Manual</li> </ul> |
| Setting group in use | Setting group 1...8 active   |

### 4.5.3 Parallel voltage regulator

Automatic voltage regulator function is able to control up to four transformer tap changers in parallel with plug and play GOOSE configuration. Tap control can be switched between parallel and independent control modes. Mimic can be set up to display feedback from each transformer. Tap control can be either in "Master & follower" mode or "Circulating current" control mode.

#### Setting up communication between the devices

Enable IEC61850 at *Communication* → *Protocols* → *IEC61580/GOOSE* → *IEC61850* with *Enable IEC61850* parameter. Then enable GOOSE subscriber at *Communication* → *Protocols* → *IEC61580/GOOSE* → *GOOSE* with *GOOSE subscriber enable* parameter.

Each voltage regulating device must have a unique ID number chosen. This can be done at *Control* → *Control functions* → *Voltage regulator* menu with *Local parallel transformer ID* parameter. Define the total number of voltage regulating devices with *Parallel group relays* parameter. If the number of detected voltage regulating devices doesn't match with *Parallel group relays* setting, an alarm will be issued. If there are four voltage regulating devices, the devices must be given an ID from 1 to 4.



#### NOTICE!

Each time a device ID or parallel group setting is changed, the GOOSE subscriber restarts and updates automatically.

For the GOOSE communication to become operational, the following conditions need to be met:

- Voltage regulator function is enabled

- "Transformer parallel operation" parameter is set to "On"
- Local parallel transformer ID is set.

## General settings

This chapter describes parameters and settings for parallel tap changer applications. Basic settings for single tap changer applications are described in chapter titled "[Automatic voltage regulator \(90\)](#)".

Table. 4.5.3 - 243. General setting parameters.

| Name                           | Range  | Step | Default                              | Description  |
|--------------------------------|--|------|--------------------------------------|--|
| CT selection                   | <ul style="list-style-type: none"> <li>• CT1</li> <li>• CT2</li> </ul>   | -    | CT1                                  | Circulating current measurement mode requires current negative sequence component measurement, which is achieved by connecting three phase currents to the device CT inputs. It is necessary to choose which side CT is used for tap changer circulating current measurement.  |
| Transformer parallel operation | <ul style="list-style-type: none"> <li>• Off</li> <li>• On</li> </ul>  | -    | Off                                  | As a default, the device operates as an independent tap controller unit. For parallel operation use choose "On" instead. This activates all hidden parallel tap control menus.   |
| Parallel operation             | <ul style="list-style-type: none"> <li>• Parallel mode</li> <li>• Independent mode</li> </ul>                                | -    | Independent mode                     | By setting a transformer to "Independent mode", it is possible to isolate it from the parallel operation, allowing the remaining transformers to continue operating in parallel mode. This flexibility is crucial for the efficient and reliable management of power systems.  |
| Control mode                   | <ul style="list-style-type: none"> <li>• Auto</li> <li>• Manual</li> </ul>   | -    | Auto                                 | Whether automatic tap control is in use or not. This setting can be bypassed with logic programming.   |
| Local parallel hierarchy       | <ul style="list-style-type: none"> <li>• Master &amp; follower</li> <li>• Circulating reactive current</li> </ul>            | -    | Master & follower                    | Parallel control method selection. In "master follower" mode, the master operates as an independent transformer and the follower operates based on leading device operations.<br>In "circulating reactive current" mode, all devices are controlling based on a formula that is trying to minimize the circulating current and voltage difference between parallel controlled transformers.                              |
| Status                         | <ul style="list-style-type: none"> <li>• Follower</li> <li>• Master</li> </ul>   | -    | -                                    | Follower device is trying to mimic either master device tap position or tap +/- control pulses. There can be only one master device selected at a time. When communication is operational between the devices, "only one master" is monitored automatically and it is not possible to choose two masters simultaneously.<br>This parameter is only displayed when the function has been set to "Master & follower" mode. |
| Follow operation               | <ul style="list-style-type: none"> <li>• Follow master raise/lower commands</li> <li>• Follow master tap position</li> </ul> | -    | Follow master raise / lower commands | Follower devices are giving tap +/- commands based on either master tap position or master raise/lower commands.   |

| Name   | Range   | Step    | Default         | Description   |
|--|---|---------|-----------------|---|
| Allowed tap difference                       | <ul style="list-style-type: none"> <li>No diff</li> <li>1-8 steps</li> </ul>  | -       | 1 steps         | In case master device operates and following device leaves behind for more than allowed tap difference, a tap difference error will take place if maximum allowed tap difference time is exceeded.  |
| Maximum allowed tap difference time          | 0.0...1800.0 s  | 0.1 s   | 60 s            |   |
| Transformer rated apparent power (Sn)        | 1.0...400.0 MVA   | 0.1 MVA | 40.0 MVA        | These values are used for calculating transformer Xk value. Xk value is used in circulating current control mode.<br>Transformer rated voltage displays the rated voltage defined in <i>Measurements</i> → <i>Transformers</i> → <i>VT module</i> .     |
| Transformer rated voltage (Un)               | 1.0...400.0 kV  | 0.1 kV  | 20.0 kV         |   |
| Transformer short circuit impedance (Zk%)    | 1.0...20.0 %  | 0.1 %   | 3.0 %           |   |
| Local parallel transformer ID                | 1...9   | 1       | N/A             | Device ID. Each voltage regulating device must have a unique ID number to operate correctly and without communication errors.<br>Always start choosing device IDs from 1 and proceed accordingly with second, and then third optional third device etc. |
| Parallel group relays                        | <ul style="list-style-type: none"> <li>Relay IDs 1 - 2</li> <li>Relay IDs 1 - 3</li> <li>Relay IDs 1 - 4</li> </ul> | -       | Relay IDs 1 - 2 | Choose how many parallel voltage regulating devices are used in application. If more or less, than the actual used amount is selected, communication alarm will activate.   |
| Tap low/high limit blocking                  | <ul style="list-style-type: none"> <li>Disabled</li> <li>Enabled</li> </ul>   | -       | Disabled        | Once tap has reached the bottom or the top limit, control towards outside the control range is blocked. Once low or high limit is reached a corresponding alarm can be associated in output matrix and logic.   |
| Tap control failure blocking                 | <ul style="list-style-type: none"> <li>Disabled</li> <li>Enabled</li> </ul>   | -       | Disabled        | Once enabled, a possible tap control failure will disable automatic tap control in "Master & follower" mode.  |
| Clear tap control failure                    | <ul style="list-style-type: none"> <li>-</li> <li>Clear</li> </ul>  | -       | -               | Clear active tap control failure alarm.   |
| Tap control failure blocking (send remote)   | <ul style="list-style-type: none"> <li>Disabled</li> <li>Enabled</li> </ul>   | -       | Disabled        | Sends tap control failure indication to remote devices. Activates "AVR/block: remote block active" logical input in receiving devices.  |
| Communication failure blocking (send remote) | <ul style="list-style-type: none"> <li>Disabled</li> <li>Enabled</li> </ul>   | -       | Disabled        | Sends communication failure indication to remote devices. Activates "AVR/block: parallel communication failure" logical input in receiving devices.   |
| No master selected blocking (send remote)    | <ul style="list-style-type: none"> <li>Disabled</li> <li>Enabled</li> </ul>   | -       | Disabled        | Sends no master selected failure indication to remote devices. Activates "AVR/block: no master selected" logical input in receiving devices.  |

| Name                                    | Range   | Step | Default  | Description  |
|---|---|------|----------|--|
| Tap differential blocking (send remote) | <ul style="list-style-type: none"> <li>Disabled</li> <li>Enabled</li> </ul> | -    | Disabled | Sends tap differential failure indication to remote devices. Activates "AVR/block: tap differential failure" logical input in receiving devices. |

## Settings

Table. 4.5.3 - 244. General setting parameters.

| Name                                     | Range   | Step     | Default    | Description   |
|--|---|----------|------------|---|
| Tap voltage measurement                  | <ul style="list-style-type: none"> <li>U12</li> <li>U23</li> <li>U31</li> <li>U4 input</li> </ul> | -        | U12        | Select tap voltage measurement input.   |
| U>/< fast tap recontrol delay T2 in use  | <ul style="list-style-type: none"> <li>Not in use</li> <li>In use</li> </ul>                      | -        | Not in use | Activate fast tap re-control for independent and master follower schemes. Fast re-control delay is used if first control command is not sufficient to achieve proper system voltage level.  |
| U> setting (+UTGT)                       | 0.10...30.00 %Un  | 0.01 %Un | 1.50 %Un   | UTGT setting window operates as a pickup for an independent transformer. In master/follower mode, the master device operates as an independent transformer device and uses UTGT setting for operation. Follower device follows master activity. Same U>/U< setting is also used in circulating reactive current mode. |
| U< setting (-UTGT)                       |   |          |            |   |
| U>/< T1 time delay (DT)                  | 0.000...1800.000 s  | 0.001 s  | 6.000 s    | This time delay is used in master/follower mode and when transformer operates as an independent unit.   |
| U>/< T2 fast recontrol delay (DT)        | 0.000...1800.000 s  | 0.001 s  | 30.000 s   | This time delay is used in master/follower mode and when transformer operates as an independent unit.   |
| Reactive control factor k                | 0.1...10.0  | 0.1      | 1.0        | Reactive control factor for circulating reactive current mode.  |
| Circulating current time delay (Slow T1) | 0.000...1800.000 s  | 0.001 s  | 20.0 s     | Primary tap control time delay in circulating reactive current mode. Runs when pickup conditions for ICRC mode are fulfilled.   |
| Circulating current time delay (Fast T2) | 0.000...1800.000 s  | 0.001 s  | 10.0 s     | Faster secondary time delay for ICRC mode. Follows T1 delay in case conditions are met.   |

## Measurements

The following measurements are available in the function menus.

Table. 4.5.3 - 245. Measurements used by the parallel voltage regulator function.

| Name                                | Range                       | Step     | Description   |
|-------------------------------------|-----------------------------|----------|---|
| Circulating current (A)             | -50000.00...50000.00<br>A   | 0.01 A   | Measured circulating reactive current amplitude and direction (+/-) from our device perspective                                     |
| Circulating current deviation (%Un) | -50000.00...50000.00<br>%Un | 0.01 %Un | Measured circulating reactive current amplitude and direction (+/-) <u>converted to voltage</u> from our device perspective. [Idev] |
| Voltage deviation (%Un)             | -50000.00...50000.00<br>%Un | 0.01 %Un | Voltage deviation indicates the difference between measured bus voltage level and nominal bus voltage. [Udev]                       |
| Total deviation (%Un)               | -50000.00...50000.00<br>%Un | 0.01 %Un | Total deviation combines the measured voltage deviation together with circulating current (voltage) deviation. [Dtot]               |

The following measurements can be added to the device display mimic:

- Transformer ID status to mimic, own transformer ID to display (variable number)
- Circulating current (A), circulating current Amperage
- Circulating current deviation (%Un), circulating current amplitude as per voltage
- Voltage deviation (%Un), bus voltage deviation to nominal
- Total deviation (%Un), bus voltage + circulating current total deviation
- Tap voltage (kV), measured tap voltage (kV)
- Voltage difference (kV), measured voltage difference to nominal bus voltage level (kV)
- Time left to operation (s), estimated time left to tap control
- Voltage now (kV), measured bus voltage (kV)
- Voltage difference to set target, indicates the difference between measured voltage and target voltage
- Voltage set now to, indicates the tap control activation limit
- Tap location now (- 0 +), tap position (own transformer)
- Absolute tap location, absolute tap position (own transformer)
- T1-T4 tap location now (- 0 +), from GOOSE, tap position (other transformers)
- T1-T4 voltage deviation, from GOOSE, voltage deviation (other transformers)
- T1-T4 circulating current deviation, from GOOSE, circ. curr. %Un (other transformers)
- T1-T4 total deviation, from GOOSE, total deviation (other transformers)

Following visibility conditions are available in the mimic editor:

- Follower operation status to mimic, follow master raise/lower or tap
- AVR tap control status, when tap is controlled up or down
- T1-T4 Auto/Manual, from GOOSE, auto/manual status (other transformers)
- T1-T4 Independent/parallel, from GOOSE, independent/parallel status (other transformers)
- AVR Independent/parallel status to mimic, independent/parallel status (own transformer)
- AVR Follower/Master status to mimic, follower/master status
- AVR no master selected, no master selected among any parallel device
- No parallel communication, no parallel communication failure
- AVR tap differential failure, tap differential failure
- Tap high limit reached, tap high limit reached alarm
- Tap low limit reached, tap low limit reached alarm
- AVR circulating current mode failure, circulating reactive current failure
- Current master, which parallel device is currently master (ID value)
- Hierarchy status to mimic, single/parallel status
- Auto/Manual status to mimic

You can adjust premade default mimic for up to four parallel transformers based on application needs.

## Device internal logic VRG> signals

Following logical signals are available in parallel tap changer function (on top of independent use):

- AVR independent, parallel, master, follower, circulating reactive current, master & follower, manual, auto and tap control status input statuses are available in logic
- T1-T4 Auto/Manual
- T1-T4 Independent/Parallel
- T1-T4 tap voltage
- AVR no master selected
- AVR parallel communication failure
- AVR tap differential failure
- AVR circulating current mode failure

## Circulating reactive current operating mode

In circulating reactive current mode, the tap control is decided based on several criteria's:

- Current tap position value
- Bus/tap voltage level compared to the nominal value ( $U_{dev}$ )
- Measured circulating reactive current amplitude and direction ( $I_{dev}$ )

Once above-mentioned terms are fulfilled, tap control takes place after deviation delay T1 has passed. In case one control step will not resolve the matter, another step is taken with faster time delay T2.

In master & follower mode, the tap control operation is based on  $UTGT$  +/- voltage windows. Once voltage drops or increases the set limit, master device controls and following device will follow. Few basic operating principles are presented below:

Figure. 4.5.3 - 132. VRG> circulating reactive current mode operating principle.

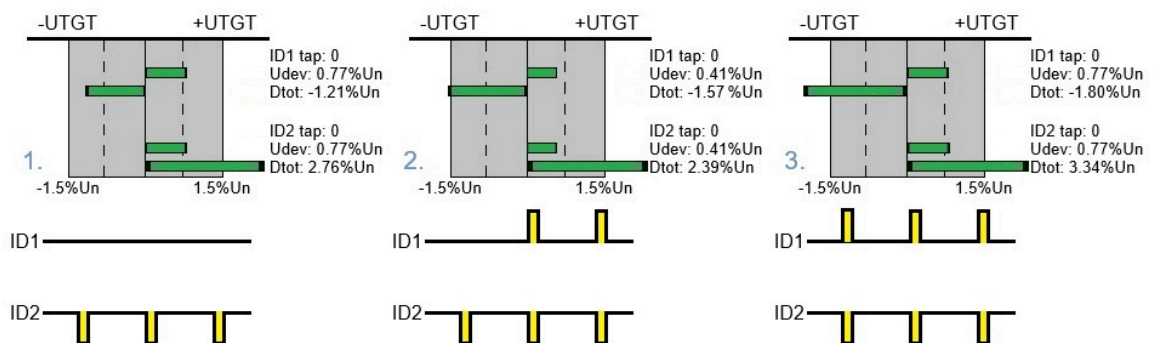

1. Example 1: Voltage deviation ( $U_{DEV}$ ) is higher than 50% of the  $UTGT$  setting (1.50%  $U_n$ ). Circulating current creates its own effect on the total deviation, causing transformer ID1's deviation to drop to  $-1.21\% U_n$ , which is less than the  $UTGT$  setting. The total deviation of transformer ID2 is  $+2.76\% U_n$ , and, as shown in the picture above, ID2 controls the tap downward.
2. Example 2: The voltage deviation ( $U_{DEV}$ ) is less than 50% of the  $UTGT$  setting of 1.50%  $U_n$ . The circulating current creates its own effect on the total deviation, causing transformer ID1's total deviation to drop to  $-1.57\% U_n$ , which is higher than the  $UTGT$  setting. The total deviation of transformer ID2 is  $+2.39\% U_n$  and, as shown in the picture above, ID2 controls the tap downward. However, if the situation persists, ID2 will attempt another downward tap control while transformer ID1 controls the tap upward.

3. Example 3: The voltage deviation ( $U_{DEV}$ ) is less than 50% of the UTGT setting ( $1.50\% U_n$ ). Transformer ID1's total deviation drops to  $-1.80\% U_n$ , which is higher than the UTGT setting. The total deviation for Transformer ID2 is  $+3.34\% U_n$ , and, as shown in the figure above, ID2 controls the tap downwards at the same time that Transformer ID1 controls the tap upwards.

**NOTICE!**

Circulating current mode follows "Max control pulse length" and "Minimum time between pulses" time delays. In case maximum control pulse length is 2 seconds and time between is 5 seconds, there is total of 7 second delay between T1 timer control command and starting of timer T2. The same applies if T2 timer is rerun multiple times.

Figure. 4.5.3 - 133. VRG> circulating reactive current mode

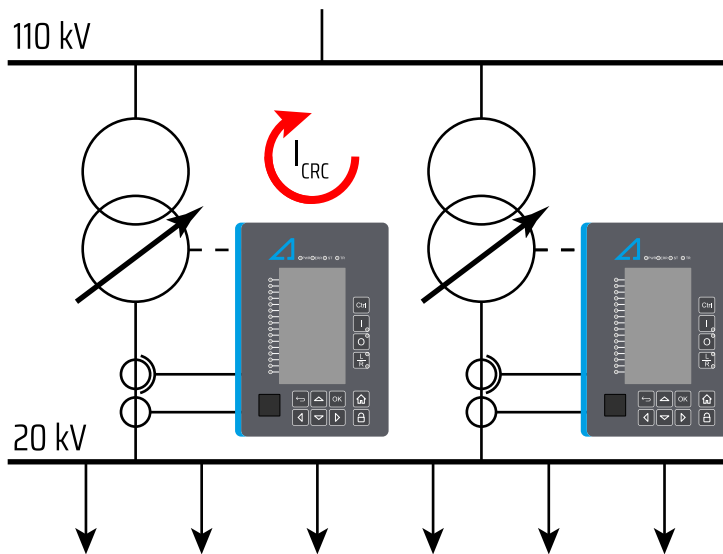

To run circulating reactive current mode properly, some transformer nameplate values such as transformer rated apparent power  $S_n$ , transformer rated voltage  $U_n$  and transformer short circuit impedance  $Z_k$  is required. All other data comes automatically via GOOSE messaging once communication between the devices has been established.

Figure. 4.5.3 - 134. Circulating reactive current mathematical formulas below:

$$X_k = \frac{U_n^2 / \sqrt{3}}{S_n} \times Z_k$$

$$I_L = \sum_{k=1}^N I_k$$

$$B_P = \sum_{K=1}^N \frac{1}{X_k}$$

$$I_{Lm} = \text{Im}(I_L) \frac{1}{X_k \times B_P}$$

$$I_{CRC} = -1 \times (\text{Im}(I_k) - I_{Lk\text{Imag}})$$

$$D_{tot} = k \times \frac{(I_{CRCk} + \frac{1}{B_P - B_k}) \times \sqrt{3}}{U_n} \times 100\%$$

- $X_k$  is transformer reactance
- $I_L$  is total combined current amplitude
- $B_P$  is total combined susceptance
- $\text{Im}(I_L)$  = current amplitude imaginary part
- $I_{Lm}$  is total imaginary current amplitude
- $I_{CRC}$  is circulating reactive current amperage
- $D_{tot}$  is circulating current as per voltage
- $K$  is circulating current reactive control factor

### Master & follower operating mode

In master & follower mode, when transformers operate in parallel, one of them has to be selected as a master and the other ones follow masters decisions. There are two ways to follow the master device.

- Follow master raise and lower commands mode: When the master device is controlling tap up or down, a signal is sent between all parallel devices and follower devices will control tap similarly to master.
- Follow master tap position mode: Following devices control tap up or down based on own tap position compared to master device tap position.

Tap differential alarm is available in case master and follower tap difference increases too much in set time.

## I/O and function blocking

Following conditions can be altered from AQtivate -setting tool, local device settings, with digital inputs and logical nodes/outputs. It is possible to control an input simultaneously with logic or digital input, since operation of stage uses non-volatile SR-latch. Device logic can be controlled through SCADA or device local MIMIC in case programmable function buttons are configured.

Table. 4.5.3 - 246. Logical inputs of the function.

| Setting                              | Description  |
|--------------------------------------|--|
| AVR independent                      | Change voltage regulator status to independent transformer.  |
| AVR parallel                         | Change transformer to operate in parallel with other transformer units.  |
| AVR master                           | Change parallel operating transformer to work as a master. Only one master can be selected at a time, in case communication is properly set. |
| AVR follower                         | Change parallel operating transformer to work as a follower. Once all parallel devices are followers, a new master can be selected.          |
| AVR circulating reactive current     | Change parallel operating device operation mode to circulating reactive current.   |
| AVR master & follower                | Change parallel operating device operation mode to master & follower.  |
| AVR manual                           | Change AVR tap control to manual mode.   |
| AVR auto                             | Change AVR tap control to auto mode.   |
| Tap control status                   | Indicates if tap controller is in normal state or in fail state after unsuccessful tap control.  |
| AVR manual raise                     | Raise transformer tap position manually while operating in manual mode.  |
| AVR manual lower                     | Lower transformer tap position manually while operating in manual mode.  |
| T1-T4 Auto/Manual                    | Parallel transformers 1-4 control auto or manual.  |
| T1-T4 Independent/Parallel           | Parallel transformers 1-4 mode independent or parallel.  |
| T1-T4 tap voltage                    | Parallel transformers 1-4 tap voltage level.   |
| AVR no master selected               | None of parallel transformers operates as master.  |
| AVR parallel communication failure   | One or several transformers are not communicating properly due to setting error or failure in system.  |
| AVR tap differential failure         | Follower device was not able to achieve master devices tap position in set time.   |
| AVR circulating current mode failure | Circulating current mode is in failure state.  |

Automatic voltage regulator can be blocked internally with two inputs. "AVR Block control outs" blocks output relay controls but doesn't block event activations. "AVR Block op and outs" blocks all operation.

Table. 4.5.3 - 247. Suggested signals to use for blocking the AVR function.

| Signal                                     | Description   |
|--|---|
| AVR no Master selected                     | This signal activates when function is in parallel mode, master&follower local parallel hierarchy is selected and when there is no master selected between any of the parallel device.                  |
| AVR no parallel communication              | Signal activates in case communication is unplugged or interrupted for any reason or device ID/group is set wrong.  |
| AVR tap differential failure               | Tap differential failure activates when master and follower unit tap difference is greater than set limit "allowed tap difference" and operating time "maximum allowed tap difference time" has passed. |
| AVR circulating current mode failure: ICRC | ICRC mode failure is not yet implemented and signal is forced to stay active (1).   |

### 4.5.4 Setting group selection

All device types support up to eight (8) separate setting groups. The Setting group selection function block controls the availability and selection of the setting groups. By default, only Setting group 1 (SG1) is active and therefore the selection logic is idle. When more than one setting group is enabled, the setting group selector logic takes control of the setting group activations based on the logic and conditions the user has programmed.

Figure. 4.5.4 - 135. Simplified function block diagram of the setting group selection function.

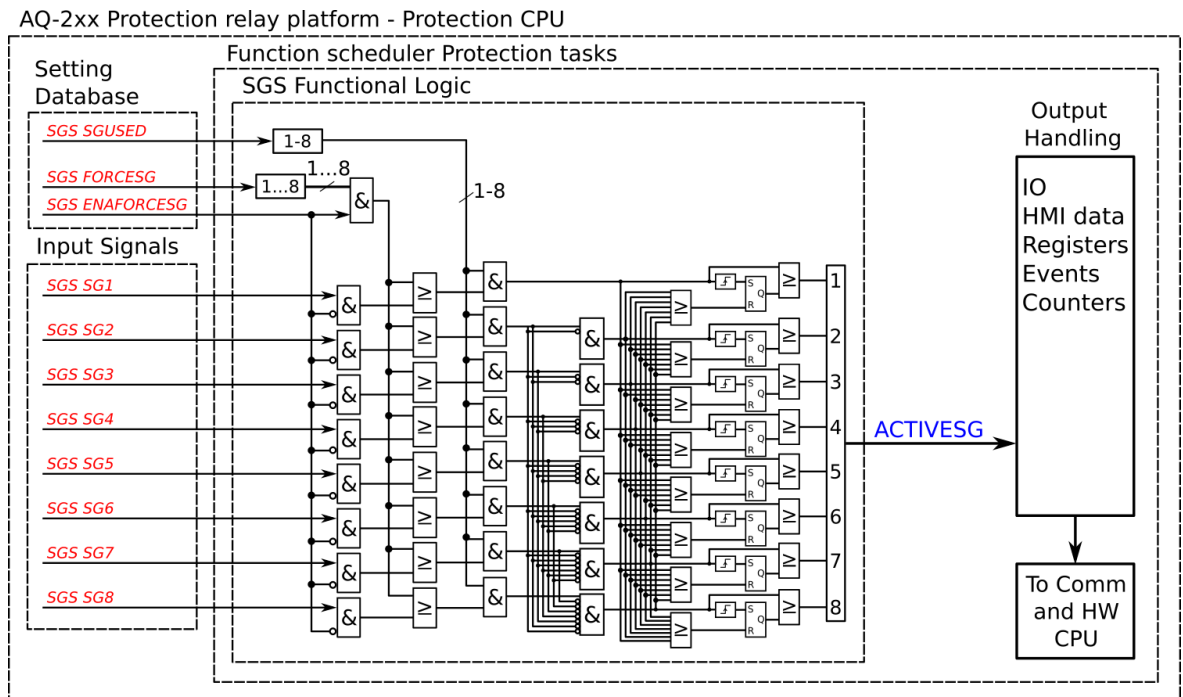

Setting group selection can be applied to each of the setting groups individually by activating one of the various internal logic inputs and connected digital inputs. The user can also force any of the setting groups on when the "Force SG change" setting is enabled by giving the wanted quantity of setting groups as a number in the communication bus or in the local HMI, or by selecting the wanted setting group from *Control* → *Setting groups*. When the forcing parameter is enabled, the automatic control of the local device is overridden and the full control of the setting groups is given to the user until the "Force SG change" is disabled again.

Setting groups can be controlled either by pulses or by signal levels. The setting group controller block gives setting groups priority values for situations when more than one setting group is controlled at the same time: the request from a higher-priority setting group is taken into use.

Setting groups follow a hierarchy in which setting group 1 has the highest priority, setting group 2 has second highest priority etc. If a static activation signal is given for two setting groups, the setting group with higher priority will be active. If setting groups are controlled by pulses, the setting group activated by pulse will stay active until another setting groups receives an activation signal.

Figure. 4.5.4 - 136. Example sequences of group changing (control with pulse only, or with both pulses and static signals).

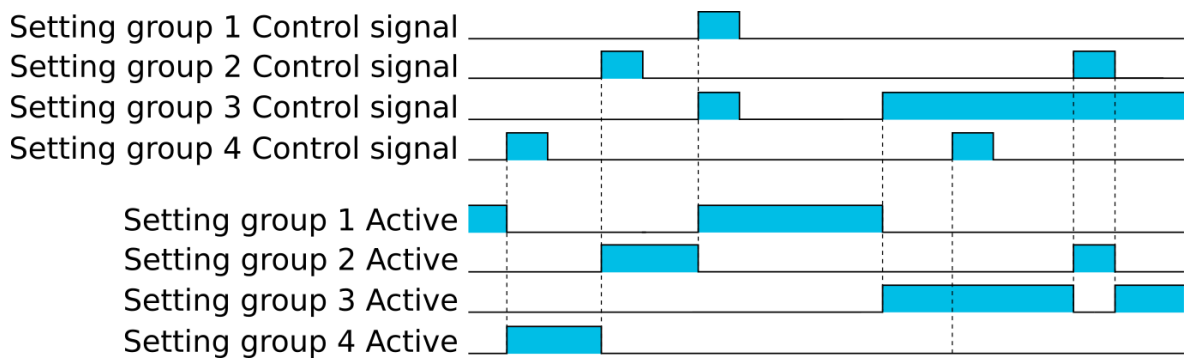

### Settings and signals

The settings of the setting group control function include the active setting group selection, the forced setting group selection, the enabling (or disabling) of the forced change, the selection of the number of active setting groups in the application, as well as the selection of the setting group changed remotely. If the setting group is forced to change, the corresponding setting group must be enabled and the force change must be enabled. Then, the setting group can be set from communications or from HMI to any available group. If the setting group control is applied with static signals right after the "Force SG" parameter is released, the application takes control of the setting group selection.

Table. 4.5.4 - 248. Settings of the setting group selection function.

| Name                 | Range  | Default | Description                             |
|----------------------|--|---------|---|
| Active setting group | <ul style="list-style-type: none"> <li>• SG1</li> <li>• SG2</li> <li>• SG3</li> <li>• SG4</li> <li>• SG5</li> <li>• SG6</li> <li>• SG7</li> <li>• SG8</li> </ul> | SG1     | Displays which setting group is active. |

| Name                        | Range  | Default  | Description   |
|-----------------------------|--|----------|---|
| Force setting group         | <ul style="list-style-type: none"> <li>• None</li> <li>• SG1</li> <li>• SG2</li> <li>• SG3</li> <li>• SG4</li> <li>• SG5</li> <li>• SG6</li> <li>• SG7</li> <li>• SG8</li> </ul>             | None     | The selection of the overriding setting group. After "Force SG change" is enabled, any of the configured setting groups in the device can be overridden. This control is always based on the pulse operating mode. It also requires that the selected setting group is specifically controlled to ON after "Force SG" is disabled. If there are no other controls, the last set setting group remains active. |
| Force setting group change  | <ul style="list-style-type: none"> <li>• Disabled</li> <li>• Enabled</li> </ul>  | Disabled | The selection of whether the setting group forcing is enabled or disabled. This setting has to be active before the setting group can be changed remotely or from a local HMI. This parameter overrides the local control of the setting groups and it remains on until the user disables it.   |
| Used setting groups         | <ul style="list-style-type: none"> <li>• SG1</li> <li>• SG1...2</li> <li>• SG1...3</li> <li>• SG1...4</li> <li>• SG1...5</li> <li>• SG1...6</li> <li>• SG1...7</li> <li>• SG1...8</li> </ul> | SG1      | The selection of the activated setting groups in the application. Newly-enabled setting groups use default parameter values.  |
| Remote setting group change | <ul style="list-style-type: none"> <li>• None</li> <li>• SG1</li> <li>• SG2</li> <li>• SG3</li> <li>• SG4</li> <li>• SG5</li> <li>• SG6</li> <li>• SG7</li> <li>• SG8</li> </ul>             | None     | This parameter can be controlled through SCADA to change the setting group remotely. Please note that if a higher priority setting group is being controlled by a signal, a lower priority setting group cannot be activated with this parameter.   |

Table. 4.5.4 - 249. Signals of the setting group selection function.

| Name            | Description  |
|-----------------|--|
| Setting group 1 | The selection of Setting group 1 ("SG1"). Has the highest priority input in setting group control. Can be controlled with pulses or static signals. If static signal control is applied, no other SG requests will be processed.   |
| Setting group 2 | The selection of Setting group 2 ("SG2"). Has the second highest priority input in setting group control. Can be controlled with pulses or static signals. If static signal control is applied, no requests with a lower priority than SG1 will be processed.              |
| Setting group 3 | The selection of Setting group 3 ("SG3"). Has the third highest priority input in setting group control. Can be controlled with pulses or static signals. If static signal control is applied, no requests with a lower priority than SG1 and SG2 will be processed.       |
| Setting group 4 | The selection of Setting group 4 ("SG4"). Has the fourth highest priority input in setting group control. Can be controlled with pulses or static signals. If static signal control is applied, no requests with a lower priority than SG1, SG2 and SG3 will be processed. |
| Setting group 5 | The selection of Setting group 5 ("SG5"). Has the fourth lowest priority input in setting group control. Can be controlled with pulses or static signals. If static signal control is applied, SG6, SG7 and SG8 requests will not be processed.                            |

| Name            | Description  |
|-----------------|--|
| Setting group 6 | The selection of Setting group 6 ("SG6"). Has the third lowest priority input in setting group control. Can be controlled with pulses or static signals. If static signal control is applied, SG7 and SG8 requests will not be processed.  |
| Setting group 7 | The selection of Setting group 7 ("SG7"). Has the second lowest priority input in setting group control. Can be controlled with pulses or static signals. If static signal control is applied, only SG8 requests will not be processed.  |
| Setting group 8 | The selection of Setting group 8 ("SG8"). Has the lowest priority input in setting group control. Can be controlled with pulses or static signals. If static signal control is applied, all other SG requests will be processed regardless of the signal status of this setting group. |

## Events

The setting group selection function block (abbreviated "SGS" in event block names) generates events from the status changes in the events listed below. The user can select which event messages are stored in the main event buffer: ON, OFF, or both. The events triggered by the function are recorded with a time stamp.

Table. 4.5.4 - 250. Event messages.

| Event block name | Event names                                |
|------------------|--|
| SGS              | SG2...8 Enabled/Disabled                   |
| SGS              | SG1...8 Request ON/OFF                     |
| SGS              | Remote Change SG Request ON/OFF            |
| SGS              | Local Change SG Request ON/OFF             |
| SGS              | Force Change SG ON/OFF                     |
| SGS              | SG Request Fail Not configured SG ON/OFF   |
| SGS              | Force Request Fail Force ON/OFF            |
| SGS              | SG Req. Fail Lower priority Request ON/OFF |
| SGS              | SG1...8 Active ON/OFF                      |

### 4.5.5 Object control and monitoring

The object control and monitoring function takes care of both for circuit breakers and disconnectors. The monitoring and controlling are based on the statuses of the device's configured digital inputs and outputs. The number of controllable and monitored objects in each device depends on the device type and amount of digital inputs. One controllable object requires a minimum of two (2) output contacts. The status monitoring of one monitored object usually requires two (2) digital inputs. Alternatively, object status monitoring can be performed with a single digital input: the input's active state and its zero state (switched to 1 with a NOT gate in the Logic editor).

An object can be controlled manually or automatically. Manual control can be done by local control, or by remote control. Local manual control can be done by devices front panel (HMI) or by external push buttons connected to devices digital inputs. Manual remote control can be done through one of the various communication protocols available (Modbus, IEC101/103/104 etc.). The function supports the modes "Direct control" and "Select before execute" while controlled remotely. Automatic controlling can be done with functions like auto-reclosing function (ANSI 79).

The main outputs of the function are the OBJECT OPEN and OBJECT CLOSE control signals. Additionally, the function reports the monitored object's status and applied operations. The setting parameters are static inputs for the function, which can only be changed by the user in the function's setup phase.

Figure. 4.5.5 - 137. Simplified function block diagram of the object control and monitoring function.

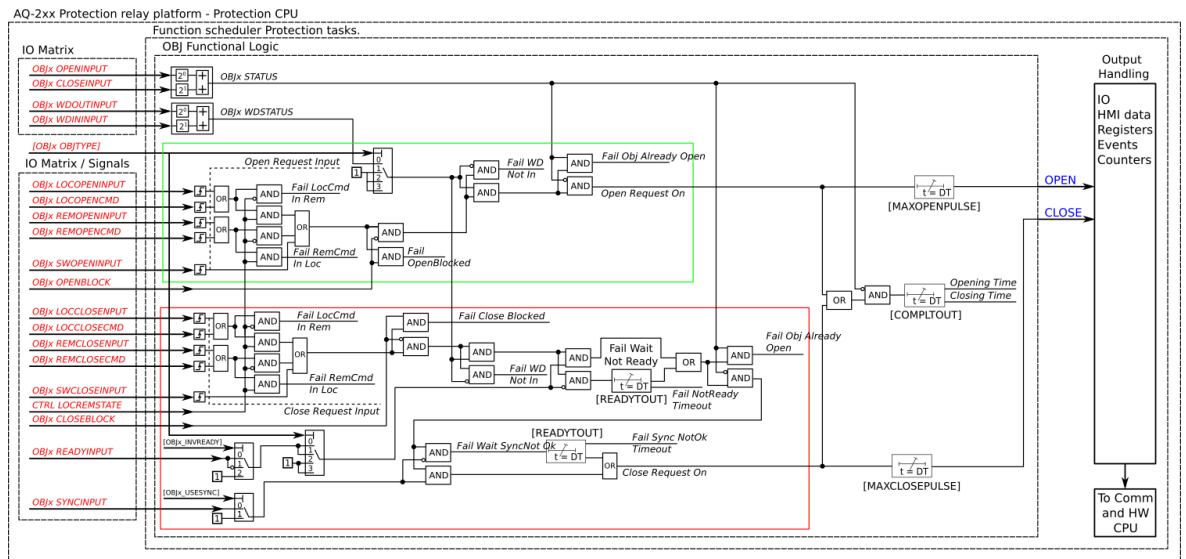

## Settings

The following parameters help the user to define the object. The operation of the function varies based on these settings and the selected object type. The selected object type determines how much control is needed and which setting parameters are required to meet those needs.

Table. 4.5.5 - 251. Object settings and status parameters.

| Name                | Range   | Default | Description  |
|---------------------|---|---------|--|
| Local/Remote status | <ul style="list-style-type: none"> <li>Local</li> <li>Remote</li> </ul> | Remote  | Displays the status of the device's "local/remote" switch. Local controls cannot override the open and close commands while device is in "Remote" status. The remote controls cannot override the open and close commands while device is in "Local" status. |

| Name                          | Range  | Default         | Description  |
|-------------------------------|--|-----------------|--|
| Object status force to        | <ul style="list-style-type: none"> <li>• Normal</li> <li>• Openreq On</li> <li>• Closereq On</li> <li>• Opensignal On</li> <li>• Closesignal On</li> <li>• WaitNoRdy On</li> <li>• WaitNoSnc On</li> <li>• NotrdyFail On</li> <li>• NosyncFail On</li> <li>• Opentout On</li> <li>• Clotout On</li> <li>• OpenreqUSR On</li> <li>• CloreqUSR On</li> </ul> | Normal          | Force the status of the function. Visible only when <i>Enable stage forcing</i> parameter is enabled in <i>General</i> menu.   |
| OBJ LN mode                   | <ul style="list-style-type: none"> <li>• On</li> <li>• Blocked</li> <li>• Test</li> <li>• Test/Blocked</li> <li>• Off</li> </ul>   | On              | Set mode of OBJ block.<br>This parameter is visible only when <i>Allow setting of individual LN mode</i> is enabled in <i>General</i> menu.  |
| OBJ LN behaviour              | <ul style="list-style-type: none"> <li>• On</li> <li>• Blocked</li> <li>• Test</li> <li>• Test/Blocked</li> <li>• Off</li> </ul>   | -               | Displays the mode of OBJ block.<br>This parameter is visible only when <i>Allow setting of individual LN mode</i> is enabled in <i>General</i> menu.   |
| Object name                   | -  | Objectx         | The user-set name of the object, at maximum 32 characters long.  |
| Object type                   | <ul style="list-style-type: none"> <li>• Withdrawable circuit breaker</li> <li>• Circuit breaker</li> <li>• Disconnecter (MC)</li> <li>• Disconnecter (GND)</li> </ul>   | Circuit breaker | The selection of the object type. This selection defines the number of required digital inputs for the monitored object. This affects the symbol displayed in the HMI and the monitoring of the circuit breaker. It also affects whether the withdrawable cart is in/out status is monitored. See the next table ("Object types") for a more detailed look at which functionalities each of the object types have. |
| Objectx Breaker status        | <ul style="list-style-type: none"> <li>• Intermediate</li> <li>• Open</li> <li>• Closed</li> <li>• Bad</li> </ul>  | -               | Displays the status of breaker. Intermediate is displayed when neither of the status signals (open or close) are active. Bad status is displayed when both status signals (open and close) are active.   |
| Objectx Withdraw status       | <ul style="list-style-type: none"> <li>• WDIntermediate</li> <li>• WDCartOut</li> <li>• WDCart In</li> <li>• WDBad</li> <li>• Not in use</li> </ul>  | -               | Displays the status of circuit breaker cart. WDIntermediate is displayed when neither of the status signals (in or out) are active. WDBad status is displayed when both status signals (in and out) are active. If the selected object type is not set to "Withdrawable circuit breaker", this setting displays the "No in use" option.  |
| Additional status information | <ul style="list-style-type: none"> <li>• Open Blocked</li> <li>• Open Allowed</li> <li>• Close Blocked</li> <li>• Close Allowed</li> <li>• Object Ready</li> <li>• Object Not Ready</li> <li>• Sync Ok</li> <li>• Sync Not Ok</li> </ul>   | -               | Displays additional information about the status of the object.  |

| Name                  | Range   | Default    | Description  |
|-----------------------|---|------------|--|
| Use Synchrocheck      | <ul style="list-style-type: none"> <li>Not in use</li> <li>Synchrocheck in use</li> </ul>           | Not in use | <p>Selects whether the "Synchrocheck" condition is in use for the circuit breaker close command. If "In use" is selected the input chosen to "Sync.check status in" has to be active to be able to close circuit breaker.</p> <p>Synchrocheck status can be either an internal signal generated by synchrocheck function or digital input activation with an external synchrocheck device.</p> |
| Use Object ready      | <ul style="list-style-type: none"> <li>Ready High</li> <li>Ready Low</li> <li>Not in use</li> </ul> | Not in use | <p>Selects whether the "Object ready" condition is in use for the circuit breaker close command. If in use the signal connected to "Object ready status In" has to be high or low to be able to close the breaker (depending on "Ready High or Low" selection).</p>  |
| Open requests         | 0...2 <sup>32</sup> -1  | -          | Displays the number of successful "Open" requests.   |
| Close requests        | 0...2 <sup>32</sup> -1  | -          | Displays the number of successful "Close" requests.  |
| Open requests failed  | 0...2 <sup>32</sup> -1  | -          | Displays the number of failed "Open" requests.   |
| Close requests failed | 0...2 <sup>32</sup> -1  | -          | Displays the number of failed "Close" requests.  |
| Clear statistics      | <ul style="list-style-type: none"> <li>-</li> <li>Clear</li> </ul>                                  | -          | <p>Clears the request statistics, setting them back to zero (0). Automatically returns to "-" after the clearing is finished.</p>  |

Table. 4.5.5 - 252. Object types.

| Name                         | Functionalities   | Description  |
|------------------------------|---|--|
| Withdrawable circuit breaker | Breaker cart position<br>Circuit breaker position<br>Circuit breaker control<br>Object ready check before closing breaker<br>Synchrochecking before closing breaker<br>Interlocks | The monitor and control configuration of the withdrawable circuit breaker. |
| Circuit breaker              | Position indication<br>Control<br>Object ready check before closing breaker<br>Synchrochecking before closing breaker<br>Interlocks   | The monitor and control configuration of the circuit breaker.              |
| Disconnecter (MC)            | Position indication<br>Control  | The position monitoring and control of the disconnecter.                   |
| Disconnecter (GND)           | Position indication   | The position indication of the earth switch.                               |

Table. 4.5.5 - 253. I/O.

| Signal                    | Range  | Description  |
|---------------------------|--|--|
| Objectx Open Status In    | Digital input or other logical signal selected by the user (SWx) | A link to a physical digital input. The monitored object's OPEN status. "1" refers to the active open state of the monitored object.                                 |
| Objectx Close Status In   |  | A link to a physical digital input. The monitored object's CLOSE status. "1" refers to the active close state of the monitored object.                               |
| Withdrw.CartIn.Status In  |  | A link to a physical digital input. The monitored withdrawable object's position is IN. "1" means that the withdrawable object cart is in.                           |
| Withdrw.CartOut.Status In |  | A link to a physical digital input. The monitored withdrawable object's position is OUT. "1" means that the withdrawable object cart is pulled out.                  |
| Objectx Ready status In   |  | A link to a physical digital input. Indicates that status of the monitored object. "1" means that the object is ready and the spring is charged for a close command. |
| Sync.Check status In      |  | A link to a physical digital input or a synchrocheck function. "1" means that the synchrocheck conditions are met and the object can be closed.                      |
| Objectx Open Command      | OUT1...OUTx  | The physical "Open" command pulse to the device's output relay.  |
| Objectx Close Command     |  | The physical "Close" command pulse to the device's output relay.   |

Table. 4.5.5 - 254. Operation settings.

| Name                               | Range           | Step   | Default | Description  |
|------------------------------------|-----------------|--------|---------|--|
| Breaker traverse time              | 0.02...500.00 s | 0.02 s | 0.2 s   | Determines the maximum time between open and close statuses when the breaker switches. If this set time is exceeded and both open and closed status inputs are active, the status "Bad" is activated in the "Objectx Breaker status" setting. If neither of the status inputs are active after this delay, the status "Intermediate" is activated. |
| Sync wait timeout                  | 0.02...500.00 s | 0.02 s | 0.2 s   | If synchrocheck is used, the object will wait for a "synchrocheck ok" signal before giving the closing command. This parameter will cancel the command if synchronization is not achieved on time.   |
| Maximum Close command pulse length | 0.02...500.00 s | 0.02 s | 0.2 s   | Determines the maximum length for a Close pulse from the output relay to the controlled object. If the object operates faster than this set time, the control pulse is reset and a status change is detected.  |
| Maximum Open command pulse length  | 0.02...500.00 s | 0.02 s | 0.2 s   | Determines the maximum length for a Open pulse from the output relay to the controlled object. If the object operates faster than this set time, the control pulse is reset and a status change is detected.   |

| Name                        | Range           | Step   | Default | Description  |
|-----------------------------|-----------------|--------|---------|--|
| Control termination timeout | 0.02...500.00 s | 0.02 s | 10 s    | Determines the control pulse termination timeout. If the object has not changed its status in this given time the function will issue an error event and the control is ended. This parameter is common for both open and close commands.  |
| Final trip pulse length     | 0.00...500.00 s | 0.02 s | 0.2 s   | Determines the length of the final trip pulse length. When the object has executed the final trip, this signal activates. If set to 0 s, the signal is continuous. If the auto-recloser function controls the object, "final trip" signal is activated only when there are no automatic reclosings expected after opening the breaker. |

Table. 4.5.5 - 255. Control settings (DI and Application).

| Signal                             | Range  | Description  |
|------------------------------------|--|--|
| Access level for MIMIC control     | <ul style="list-style-type: none"> <li>User</li> <li>Operator</li> <li>Configurator</li> <li>Super user</li> </ul> | Defines what level of access is required for MIMIC control. The default is the "Configurator" level. |
| Objectx LOCAL Close control input  | Digital input or other logical signal selected by the user   | The local Close command from a physical digital input (e.g. a push button).                          |
| Objectx LOCAL Open control input   |  | The local Open command from a physical digital input (e.g. a push button).                           |
| Objectx REMOTE Close control input |  | The remote Close command from a physical digital input (e.g. RTU).                                   |
| Objectx REMOTE Open control input  |  | The remote Open command from a physical digital input (e.g. RTU).                                    |
| Objectx Application Close          |  | The Close command from the application. Can be any logical signal.                                   |
| Objectx Application Open           |  | The Close command from the application. Can be any logical signal.                                   |

## Blocking and interlocking

The interlocking and blocking conditions can be set for each controllable object, with Open and Close set separately. Blocking and interlocking can be based on any of the following: other object statuses, a software function or a digital input.

In order for the blocking signal to be received on time, it has to reach the function 5 ms before the control command.

## Trip circuit supervision

Trip circuit supervision monitors the wiring from auxiliary power supply, through the device's digital output, and all the way to the open coil of the breaker. It is recommended to supervise the health of the trip circuit when the breaker is closed.

The figure below presents an application scheme for trip circuit supervision with one digital input and a non-latched trip output. With this connection the current keeps flowing to the open coil of the breaker via the breaker's closing auxiliary contacts (52b) even after the circuit breaker is opened. This requires a resistor which reduces the current: this way the coil is not energized and the relay output does not need to cut off the coil's inductive current.

Figure. 4.5.5 - 138. Trip circuit supervision with one DI and one non-latched trip output.

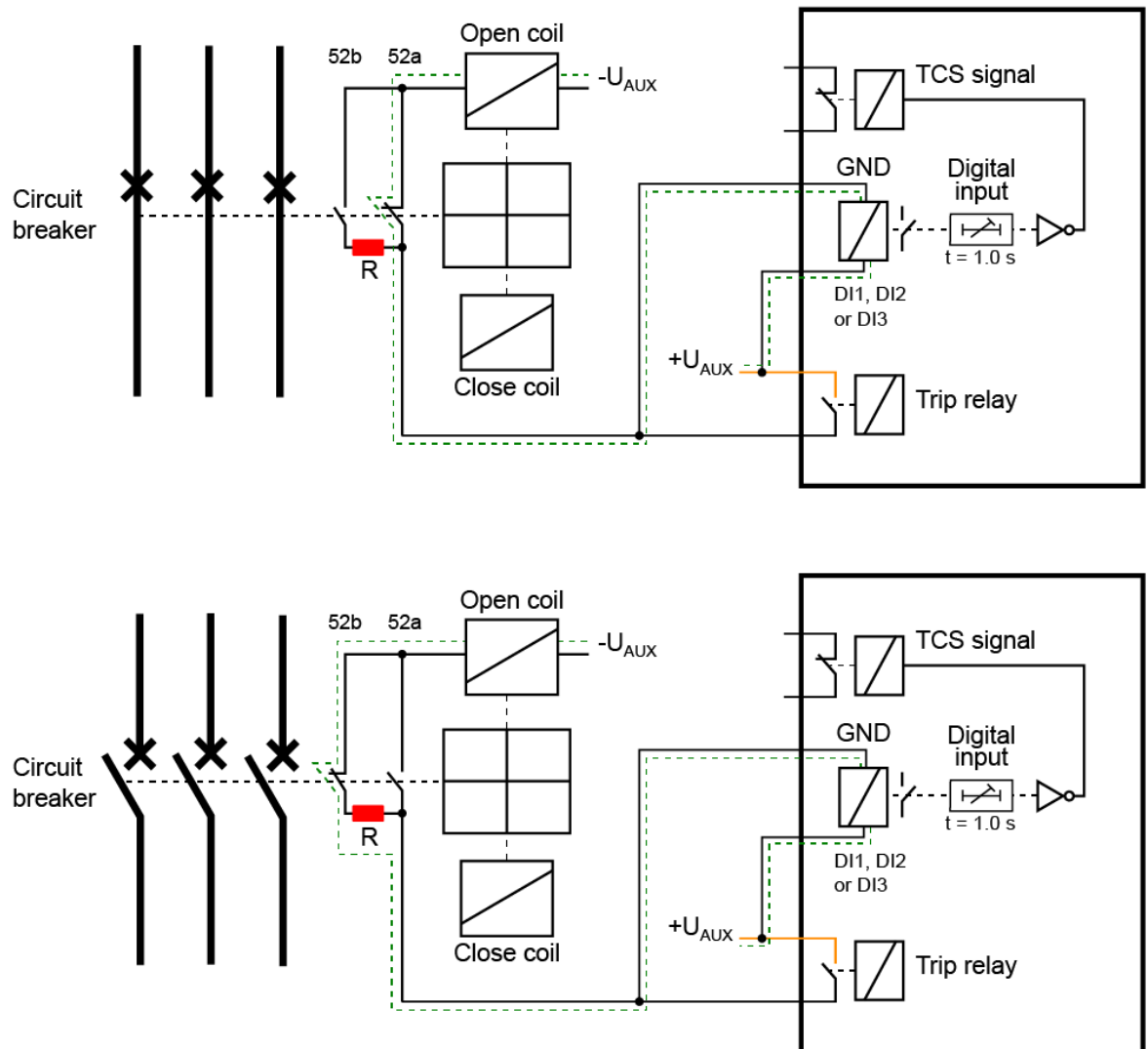

Note that the digital input that monitors the circuit is normally closed, and the same applies to the alarm relay if one is used. For monitoring and especially trip circuit supervision purposes it is recommended to use a normally closed contact to confirm the wiring's condition. An active digital input generates a less than 2 mA current to the circuit, which is usually small enough not to make the breaker's open coil operate.

When the trip relay is controlled and the circuit breaker is opening, the digital input is shorted by the trip contact as long as the breaker opens. Normally, this takes about 100 ms if the relay is non-latched. A one second activation delay should, therefore, be added to the digital input. An activation delay that is slightly longer than the circuit breaker's operations time should be enough. When circuit breaker failure protection (CBFP) is used, adding its operation time to the digital input activation time is useful. The whole digital input activation time is, therefore,  $t_{DI} = t_{CB} + t_{IEDrelease} + t_{CBFP}$ .

Figure. 4.5.5 - 139. Trip circuit supervision with high-speed output. High-speed outputs have an internal input for trip circuit supervision.

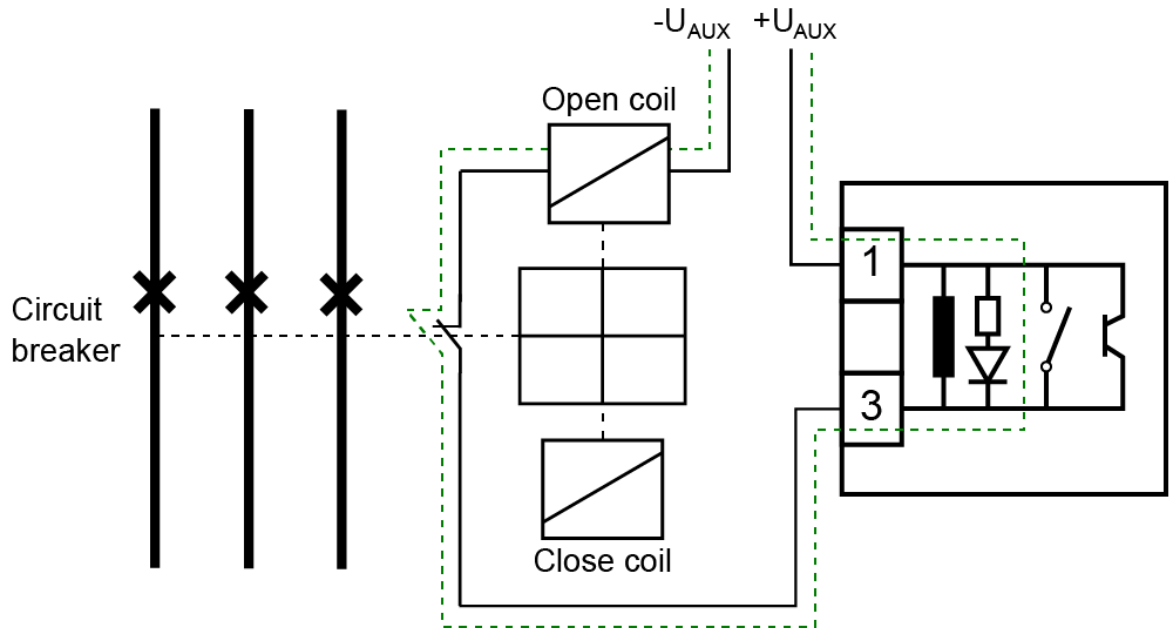

Table. 4.5.5 - 256. Trip circuit supervision settings (Control → Objects → Object X → APP CONTR → Condition monitoring).

| Name                               | Range   | Default  | Description  |
|------------------------------------|---|----------|--|
| ObjectX Trip circuit supervision   | <ul style="list-style-type: none"> <li>Disabled</li> <li>Enabled</li> </ul> | Disabled | Enables the trip circuit supervision function.                           |
| ObjectX TCS Alarm activation delay | 0.02...500.00 s   | 0.20 s   | Time delay before TCS alarm is activated.                                |
| Object1 TCS input                  | -   | -        | Defines the supervised digital input, high-speed output or other signal. |

### Object condition monitoring (circuit breaker wear monitor)

Each object has integrated circuit breaker wear monitor. The circuit breaker wear function is used for monitoring the circuit breaker's lifetime and its maintenance needs caused by interrupting currents and mechanical wear. The function uses the circuit breaker's manufacturer-supplied data for the breaker operating cycles in relation to the interrupted current magnitudes.

Figure. 4.5.5 - 140. Example of the circuit breaker interrupting life operations. Points 1 and 2 are user settable.

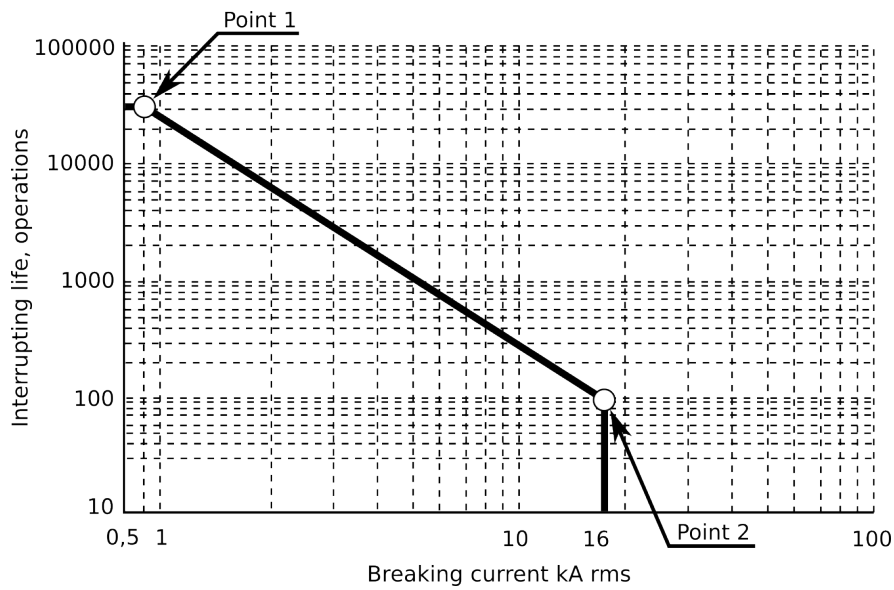

The function is triggered from the circuit breaker's "Open" command output and it monitors the three-phase current values in both the tripping moment and the normal breaker opening moment. The maximum value of interrupting life operations for each phase is calculated from these currents. The value is cumulatively deducted from the starting operations starting value. The user can set up two separate alarm levels, which are activated when the value of interrupting life operations is below the setting limit. The "Trip contact" setting defines the output that triggers the current monitoring at the breaker's "Open" command. The function's outputs are ALARM 1 and ALARM 2 signals which can be used for direct I/O controlling and user logic programming.

Figure above indicates that the circuit breaker is capable of 30 000 operations at its rated operating current of 630 A, and 100 operations at its rated fault current of 16 kA. Based on this, a single operation at 5 kA corresponds to  $30\,000/1000 = 30$  operations at the rated current. If the breaker had 20 000 operations of life remaining before this trip, then one 5 kA operation reduces its remaining life by 30 operations. Therefore, after the 5 kA trip, the breaker has 19 970 rated-current operations left.

The function block uses analog current measurement values and always uses the RMS magnitude of the current measurement input.

Table. 4.5.5 - 257. Measurement inputs of the circuit breaker wear function.

| Signal | Description                             |
|--------|---|
| IL1RMS | RMS measurement of phase L1 (A) current |
| IL2RMS | RMS measurement of phase L2 (B) current |
| IL3RMS | RMS measurement of phase L3 (C) current |

Condition monitoring parameters can be found from *Control* → *Objects* → *Object X* → *APP CONTR* → *Condition Monitoring*.

Table. 4.5.5 - 258. Breaker supervision settings and status indications.

| Name                                    | Range  | Default  | Description   |
|---|--|----------|---|
| Condition monitoring                    | <ul style="list-style-type: none"> <li>Disabled</li> <li>Enabled</li> </ul>                    | Disabled | Enables the breaker condition monitoring function.  |
| Monitoring CT side                      | <ul style="list-style-type: none"> <li>CT1</li> <li>CT2</li> </ul>                             | CT1      | Defines which current measurement module is used by the function.                               |
| Condition monitor status                | <ul style="list-style-type: none"> <li>Normal</li> <li>Alarm1 On</li> <li>Alarm2 On</li> </ul> | -        | Displays the status of the monitor.   |
| Open operations                         | 0...4 294 967 295  | -        | Displays the total number of breaker open operations.   |
| Operation time open                     | 0...4 294 967 295 ms   | -        | Displays the latest breaker opening time.   |
| Close operations                        | 0...4 294 967 295  | -        | Displays the total number of breaker close operations.  |
| Operation time close                    | 0...4 294 967 295 ms   | -        | Displays the latest breaker closing time.   |
| L1 Operations Left                      | 0...4 294 967 295  | -        | Displays the number of operations left in each phase.   |
| L2 Operations Left                      |  |          |   |
| L3 Operations Left                      |  |          |   |
| L1 Cumulative abrasion                  | 0...4 294 967 295 kA <sup>2</sup> t  | -        | Displays the amount of abrasion in each phase. See contact abraction calculation formula below. |
| L2 Cumulative abrasion                  |  |          |   |
| L3 Cumulative abrasion                  |  |          |   |
| Maximum cumulative abrasion             | 0...4 294 967 295 kA <sup>2</sup> t  | -        | Displays the value of the phase with most cumulated abrasion.                                   |
| Object Cumulated operations             | 0...4 294 967 295  | -        | Displays the total number of operations.  |
| Clear condition monitoring statistics   | <ul style="list-style-type: none"> <li>-</li> <li>Clear</li> </ul>                             | -        | Clears the operation statistics.  |
| Operations with Current 1 Value allowed | 0...200 000  | 50000    | Defines the number of operations with lower current values. See figure above.                   |
| Current 1 Value                         | 0.00...100.00 kA   | 1.00 kA  | Defines the lower current turnpoint. See figure above.  |
| Operations with Current 2 Value allowed | 0...200 000  | 100      | Defines number of operations with higher current values. See figure above.                      |
| Current 2 Value                         | 0.00...100.00 kA   | 20.00 kA | Defines the higher current turnpoint. See figure above.   |

| Name  | Range   | Default                   | Description  |
|---|---|---------------------------|--|
| Condition Alarm 1 Enable                    | <ul style="list-style-type: none"> <li>Disabled</li> <li>Enabled</li> </ul> | Disabled                  | Enables Alarm 1.   |
| Condition Alarm 1 when operations less than | 0...200 000   | 1000                      | When the number of operations left is less than value set here, Alarm 1 will activate.       |
| Abrasion sum threshold alarm                | 0...1 000 000 kA <sup>2</sup> t   | 200 000 kA <sup>2</sup> t | When the cumulated abrasion exceeds this value, contact abrasion alarm signal is activated   |
| Condition Alarm 2 Enable                    | <ul style="list-style-type: none"> <li>Disabled</li> <li>Enabled</li> </ul> | Disabled                  | Enables Alarm 2.   |
| Condition Alarm 2 when operations less than | 0...200 000   | 100                       | When the number of operations left is less than value set here, Alarm 2 will activate.       |
| Abrasion sum threshold warning              | 0...1 000 000 kA <sup>2</sup> t   | 200 000 kA <sup>2</sup> t | When the cumulated abrasion exceeds this value, contact abrasion warning signal is activated |

Contact abrasion is often approximated as being proportional to the arc energy during interruption. AQ-200 series devices calculate contact abrasion for each breaker opening using the following formula:

Figure. 4.5.5 - 141. Contact abrasion calculation formula.

$$\textit{Contact abrasion} = I^2 * t$$

Where:

- I is the measured current at the moment the device receives the open command.
- t is the measured opening time of the breaker.

The breaker opening time starts when the open command is issued and ends when the device receives the breaker open status input. For the abrasion calculation to start from a fault-initiated trip, the TRIP signals must be connected to the "Object application open" input, instead of the matrix.

If the fault current at the time of starting the circuit breaker opening is 5 kA and the total time difference between the open command and the circuit breaker open status is 100 ms, the contact abrasion for that circuit breaking will be calculated as follows:

Figure. 4.5.5 - 142. Contact abrasion example calculation.

$$\textit{Contact abrasion} = 5kA^2 * 0,1s = 2,5kA^2 * s$$

The total abrasion cumulates each time the object is opened. Abrasion is calculated separately for each phase.

- When the cumulative abrasion of any phase exceeds the "Object abrasion sum threshold alarm" setting, the "Object contact abrasion alarm" output activates.
- When the cumulative abrasion of any phase exceeds the "Object abrasion sum threshold warning" setting, the "Object contact abrasion warning" output activates.

## Events and registers

The object control and monitoring function (abbreviated "OBJ" in event block names) generates events and registers from the status changes in the events listed below. The user can select which event messages are stored in the main event buffer: ON, OFF, or both. The events triggered by the function are recorded with a time stamp.

The function also provides a resettable cumulative counter for OPEN, CLOSE, OPEN FAILED, and CLOSE FAILED events.

Table. 4.5.5 - 259. Event messages of the OBJ function.

| Event block name | Description                           |
|------------------|---------------------------------------|
| OBJX             | Object Intermediate                   |
| OBJX             | Object Open                           |
| OBJX             | Object Close                          |
| OBJX             | Object Bad                            |
| OBJX             | WD Intermediate                       |
| OBJX             | WD Out                                |
| OBJX             | WD in                                 |
| OBJX             | WD Bad                                |
| OBJX             | Open Request ON/OFF                   |
| OBJX             | Open Command ON/OFF                   |
| OBJX             | Close Request ON/OFF                  |
| OBJX             | Close Command ON/OFF                  |
| OBJX             | Open Blocked ON/OFF                   |
| OBJX             | Close Blocked ON/OFF                  |
| OBJX             | Object Ready                          |
| OBJX             | Object Not Ready                      |
| OBJX             | Sync Ok                               |
| OBJX             | Sync Not Ok                           |
| OBJX             | Open Command Fail                     |
| OBJX             | Close Command Fail                    |
| OBJX             | Final trip ON/OFF                     |
| OBJX             | Contact Abrasion Alarm ON/OFF         |
| OBJX             | Switch Operating Time Exceeded ON/OFF |
| OBJX             | XCBR Loc ON/OFF                       |

| Event block name | Description                          |
|------------------|--------------------------------------|
| OBJX             | XSWI Loc ON/OFF                      |
| OBJX             | OBJX Cond monitoring alarm 1 ON/OFF  |
| OBJX             | OBJX Cond monitoring alarm 2 ON/OFF  |
| OBJX             | OBJX Trip Circuit Supervision ON/OFF |

The function registers its operation into the last twelve (12) time-stamped registers. The table below presents the structure of the function's register content.

Table. 4.5.5 - 260. Register content.

| Name                         | Description  |
|------------------------------|--|
| Date and time                | dd.mm.yyyy hh:mm:ss.mss  |
| Event                        | Event name   |
| Recorded Object opening time | Time difference between the object receiving an "Open" command and the object receiving the "Open" status. |
| Recorded Object closing time | Time difference between the object receiving a "Close" command and object receiving the "Closed" status.   |
| Object status                | The status of the object.  |
| WD status                    | The status of the withdrawable circuit breaker.  |
| Open fail                    | The cause of an "Open" command's failure.  |
| Close fail                   | The cause of a "Close" command's failure.  |
| Open command                 | The source of an "Open" command.   |
| Close command                | The source of an "Open" command.   |
| General status               | The general status of the function.  |

### 4.5.6 Indicator object monitoring

The indicator object monitoring function takes care of the status monitoring of disconnectors. The function's sole purpose is indication and does not therefore have any control functionality. To control circuit breakers and/or disconnectors, please use the Object control and monitoring function. The monitoring is based on the statuses of the configured device's digital inputs. The number of monitored indicators in a device depends on the device type and available inputs. The status monitoring of one monitored object usually requires two (2) digital inputs. Alternatively, object status monitoring can be performed with a single digital input: the input's active state and its zero state (switched to 1 with a NOT gate in the Logic editor).

The outputs of the function are the monitored indicator statuses (Open, Close, Intermediate and Bad). The setting parameters are static inputs for the function, which can only be changed by the use in the function's setup phase.

The inputs of the function are the binary status indications. The function generates general time stamped ON/OFF events to the common event buffer from each of the following signals: OPEN, CLOSE, BAD and INTERMEDIATE event signals. The time stamp resolution is 1 ms.

## Settings

Function uses available hardware and software digital signal statuses. These input signals are also setting parameters for the function.

Table. 4.5.6 - 261. Indicator status.

| Name   | Range   | Default | Description   |
|--|---|---------|---|
| Indicator name ("Ind. Name")                     | -   | IndX    | The user-set name of the object, at maximum 32 characters long.   |
| IndicatorX Object status ("Ind.X Object Status") | <ul style="list-style-type: none"> <li>Intermediate</li> <li>Open</li> <li>Closed</li> <li>Bad</li> </ul> | -       | Displays the status of the indicator object. Intermediate status is displayed when neither of the status conditions (open or close) are active. Bad status is displayed when both of the status conditions (open and close) are active. |

Table. 4.5.6 - 262. Indicator I/O.

| Signal   | Range  | Description  |
|--|--|--|
| IndicatorX Open input ("Ind.X Open Status In")   | Digital input or other logical signal selected by the user (SWx) | A link to a physical digital input. The monitored indicator's OPEN status. "1" refers to the active "Open" state of the monitored indicator.   |
| IndicatorX Close input ("Ind.X Close Status In") | Digital input or other logical signal selected by the user (SWx) | A link to a physical digital input. The monitored indicator's CLOSE status. "1" refers to the active "Close" state of the monitored indicator. |

## Events

The indicator object monitoring function (abbreviated "CIN" in event block names) generates events from the status changes in the events listed below. The user can select which event messages are stored in the main event buffer: ON, OFF, or both. The events triggered by the function are recorded with a time stamp.

Table. 4.5.6 - 263. Event messages (instances 1-10).

| Event block name | Event names  |
|------------------|--------------|
| CIN1...10        | Intermediate |
| CIN1...10        | Open         |
| CIN1...10        | Close        |
| CIN1...10        | Bad          |

### 4.5.7 Cold load pick-up (CLPU)

The cold load pick-up function is used for detecting so-called cold load situations, where a loss of load diversity has occurred after distribution has been re-energized. The characteristics of cold load situations vary according to the types of loads individual feeders have. This means that this function needs to be set specifically according to the load type of the feeder it is monitoring. For example, in residential areas there are relatively many thermostat-controlled devices (such as heating and cooling machinery) which normally run in asynchronous cycles. When restoring power after a longer power outage, these devices demand the full start-up power which can cause the inrush current to be significantly higher than what the load current was before the outage. This is uncommon in industrial environments since the restoring of the production process takes several hours, or even days, and the power level goes back to the level it was before the outage. However, some areas of the industrial network may find the cold load pick-up function useful.

Figure. 4.5.7 - 143. Simplified function block diagram of the cold load pick-up function.

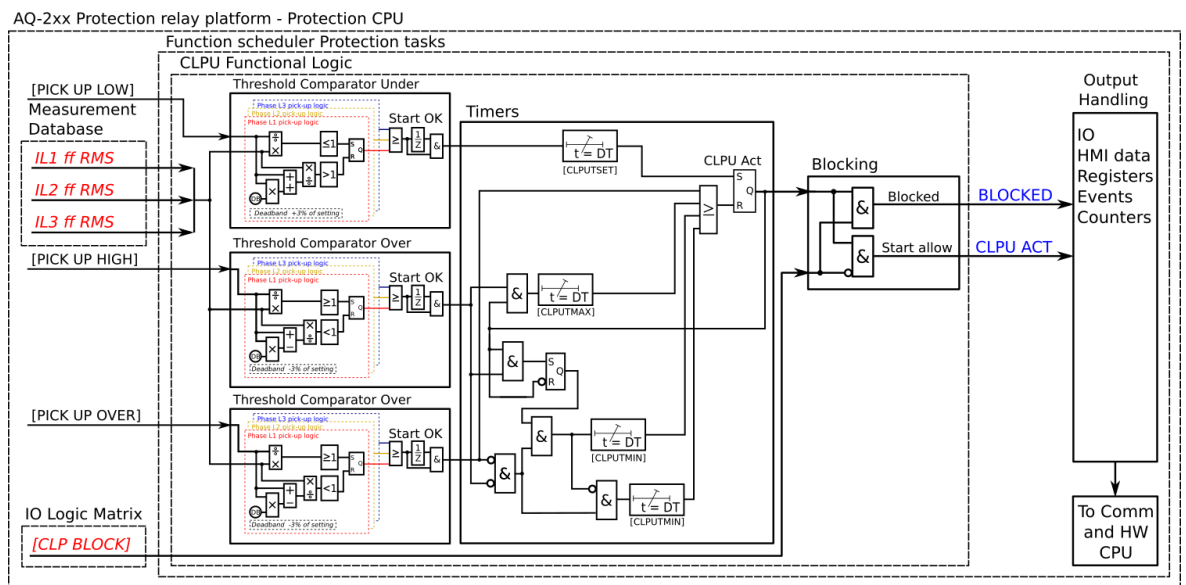

#### Measured input

The function block uses fundamental frequency component of phase current measurement values.

Table. 4.5.7 - 264. Measurement inputs of the cold load pick-up function.

| Signal               | Description   |
|----------------------|---|
| $I_{L1} \text{ RMS}$ | Fundamental frequency component of phase L1 (A) current |
| $I_{L2} \text{ RMS}$ | Fundamental frequency component of phase L2 (B) current |
| $I_{L3} \text{ RMS}$ | Fundamental frequency component of phase L3 (C) current |

#### General settings

The following general settings define the general behavior of the function. These settings are static i.e. it is not possible change them by editing the setting group.

Table. 4.5.7 - 265. General settings.

| Name             | Range  | Default | Description   |
|------------------|--|---------|---|
| CLPU LN mode     | <ul style="list-style-type: none"> <li>On</li> <li>Blocked</li> <li>Test</li> <li>Test/Blocked</li> <li>Off</li> </ul>                             | On      | Set mode of CLP block.<br>This parameter is visible only when <i>Allow setting of individual LN mode</i> is enabled in <i>General</i> menu. |
| Measurement side | <ul style="list-style-type: none"> <li>Side 1</li> <li>Side 2</li> </ul>   | Side 1  | Defines which current measurement module is used by the function.<br>Only visible when there is more than one module.                       |
| Condition        | <ul style="list-style-type: none"> <li>Normal</li> <li>Curr low</li> <li>Overcurrent</li> <li>On</li> <li>CLPU On</li> <li>CLPU blocked</li> </ul> | Normal  | Displays the status of the function.  |

### Pick-up settings

The  $I_{low}$ ,  $I_{high}$  and  $I_{over}$  setting parameters control the the pick-up and activation of the cold load pick-up function. They define the maximum and minimum allowed measured current before action from the function. The function constantly calculates the ratio between the setting values and the measured magnitude ( $I_m$ ) for each of the three phases. The reset ratio of 97 % is built into the function and is always relative to the setting value. The setting value is common for all measured phases. When the  $I_m$  exceeds the setting value (in single, dual or all phases) it triggers the pick-up operation of the function.

Setting group selection controls the operating characteristics of the function, i.e. the user or user-defined logic can change function parameters while the function is running.

Table. 4.5.7 - 266. Pick-up settings.

| Name       | Range               | Step        | Default     | Description   |
|------------|---------------------|-------------|-------------|---|
| $I_{low}$  | 0.01...40.00× $I_n$ | 0.01× $I_n$ | 0.20× $I_n$ | The pick-up setting for low current detection. All measured currents must be below this setting in order for the cold load pick-up signal to be activated.        |
| $I_{high}$ | 0.01...40.00× $I_n$ | 0.01× $I_n$ | 1.20× $I_n$ | The pick-up setting for high current detection. All measured currents must exceed this setting in order for the cold load pick-up signal to be activated.         |
| $I_{over}$ | 0.01...40.00× $I_n$ | 0.01× $I_n$ | 2.00× $I_n$ | The pick-up setting for overcurrent detection. If this setting is exceeded by any of the measured currents, the cold load pick-up signal is released immediately. |

### Read-only parameters

The function's *Info* page displays useful, real-time information on the state of the protection function. It is accessed either through the device's HMI display, or through the setting tool software when it is connected to the device and its Live Edit mode is active.

Table. 4.5.7 - 267. Information displayed by the function.

| Name              | Range   | Description   |
|-------------------|---|---|
| CLPU LN behaviour | <ul style="list-style-type: none"> <li>• On</li> <li>• Blocked</li> <li>• Test</li> <li>• Test/Blocked</li> <li>• Off</li> </ul>                    | <p>Displays the mode of CLP block.</p> <p>This parameter is visible only when <i>Allow setting of individual LN mode</i> is enabled in <i>General</i> menu.</p> |
| CLP condition     | <ul style="list-style-type: none"> <li>• Normal</li> <li>• Curr low</li> <li>• Overcurrent On</li> <li>• CLPU On</li> <li>• CLPU blocked</li> </ul> | <p>Displays status of the control function.</p>   |

### Function blocking

The blocking signal is evaluated at the start of each program cycle. The blocking signals are connected to the function's dedicated input, which can be configured in the *IO → Blocking Input Control* tab of the function.

- When the pick-up element activates and the blocking signal is not active, a CLPU ACT signal is generated, and the function starts or continues with the trip time countdown.
- When the pick-up element activates and the blocking signal is active, a BLOCKED signal is generated, and the function does not process the event further.
- When CLPU ACT signal is already active and the blocking input signal becomes active, the CLPU ACT signal is reset and BLOCKED signal is generated. The release time characteristics are then processed in the same way as when the pick-up signal is reset.

The blocking signal needs to reach the device minimum of 5 ms before the set operating delay has passed in order for the blocking to activate in time.

### Operating time characteristics

The behavior of the function's operating timers can be set for activation as well as for the situation monitoring and release of the cold load pick-up.

The table below presents the setting parameters for the function's time characteristics.

Table. 4.5.7 - 268. Setting parameters for operating time characteristics.

| Name             | Range             | Step   | Default | Description   |
|------------------|-------------------|--------|---------|---|
| T <sub>set</sub> | 0.000...1800.000s | 0.005s | 10.000s | The function's start timer which defines how long the <i>I<sub>low</sub></i> condition has to last before the cold load pick-up is activated.   |
| T <sub>max</sub> | 0.000...1800.000s | 0.005s | 30.000s | The function's maximum timer which defines how long the starting condition can last and for how long the current is allowed to be over <i>I<sub>high</sub></i> .  |
| T <sub>min</sub> | 0.000...1800.000s | 0.005s | 0.040s  | The function's minimum timer which defines how long the starting condition has to last at the minimum. If the start-up sequence includes more than one inrush situation, this parameter may be used to prolong the cold load pick-up time over the first inrush. Additionally, this parameter operates as the "reclaim" time for the function in case the inrush current is not immediately initiated in the start-up sequence. |

The six examples below showcase some typical cases with the cold load pick-up function.

Figure. 4.5.7 - 144. Example of timers and pick-up parameters (normal CLPU situation).

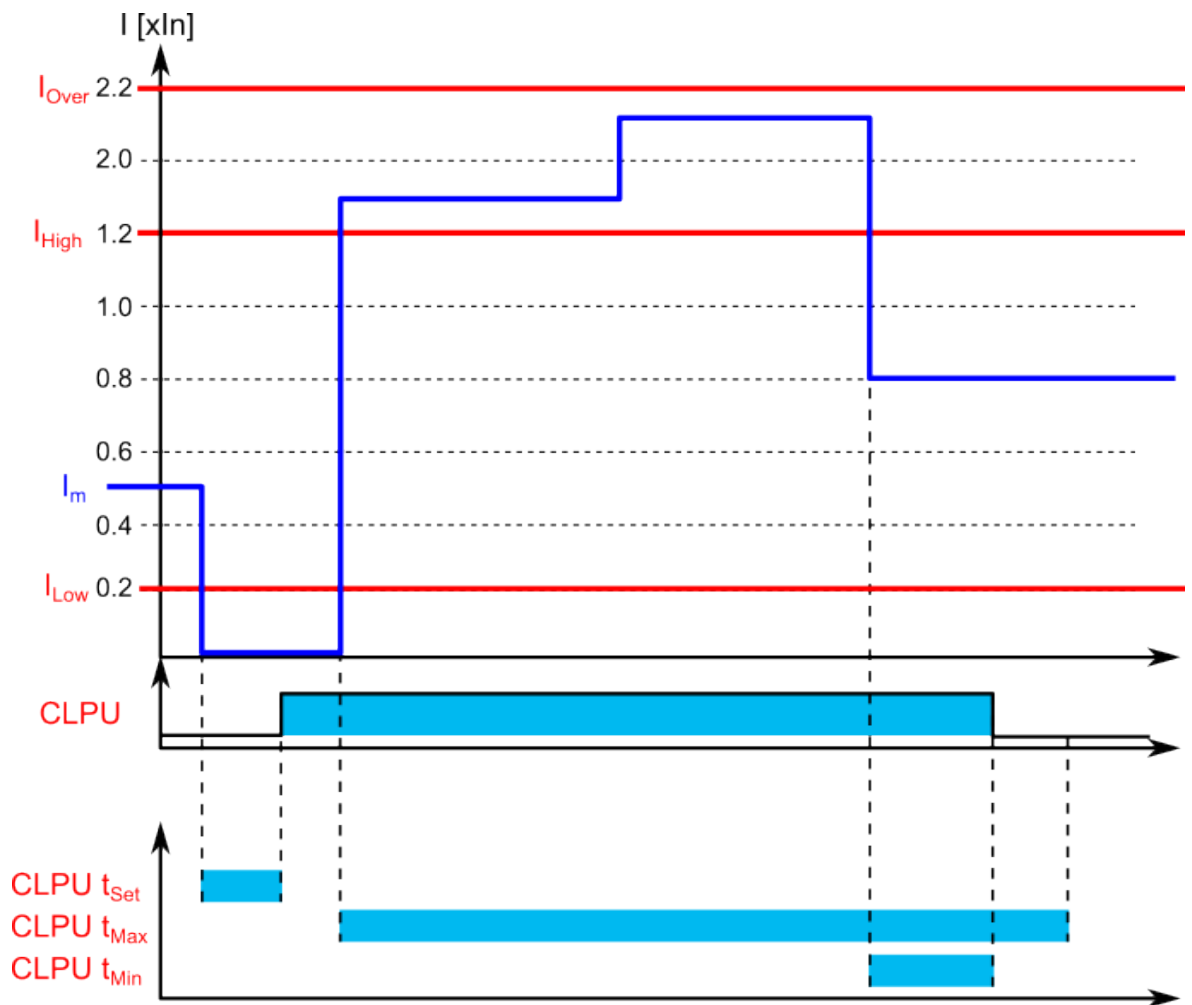

In the example above, the cold load pick-up function activates after the measured current dips below the  $I_{low}$  setting and has been there for  $T_{set}$  amount of time. When the current exceeds the  $I_{high}$  setting value, a timer starts counting towards the  $T_{max}$  time. The pick-up current is cleared before the the counter reaches the  $T_{max}$  time, when the measured current goes between of  $I_{low}$  and the  $I_{high}$ . This is when the start-up condition is considered to be over. The cold load pick-up signal can be prolonged beyond this time by setting the  $T_{min}$  to a value higher than 0.000 s.

Figure. 4.5.7 - 145. Example of timers and pick-up parameters (no cold load pick-up,  $I_{low}$  too short).

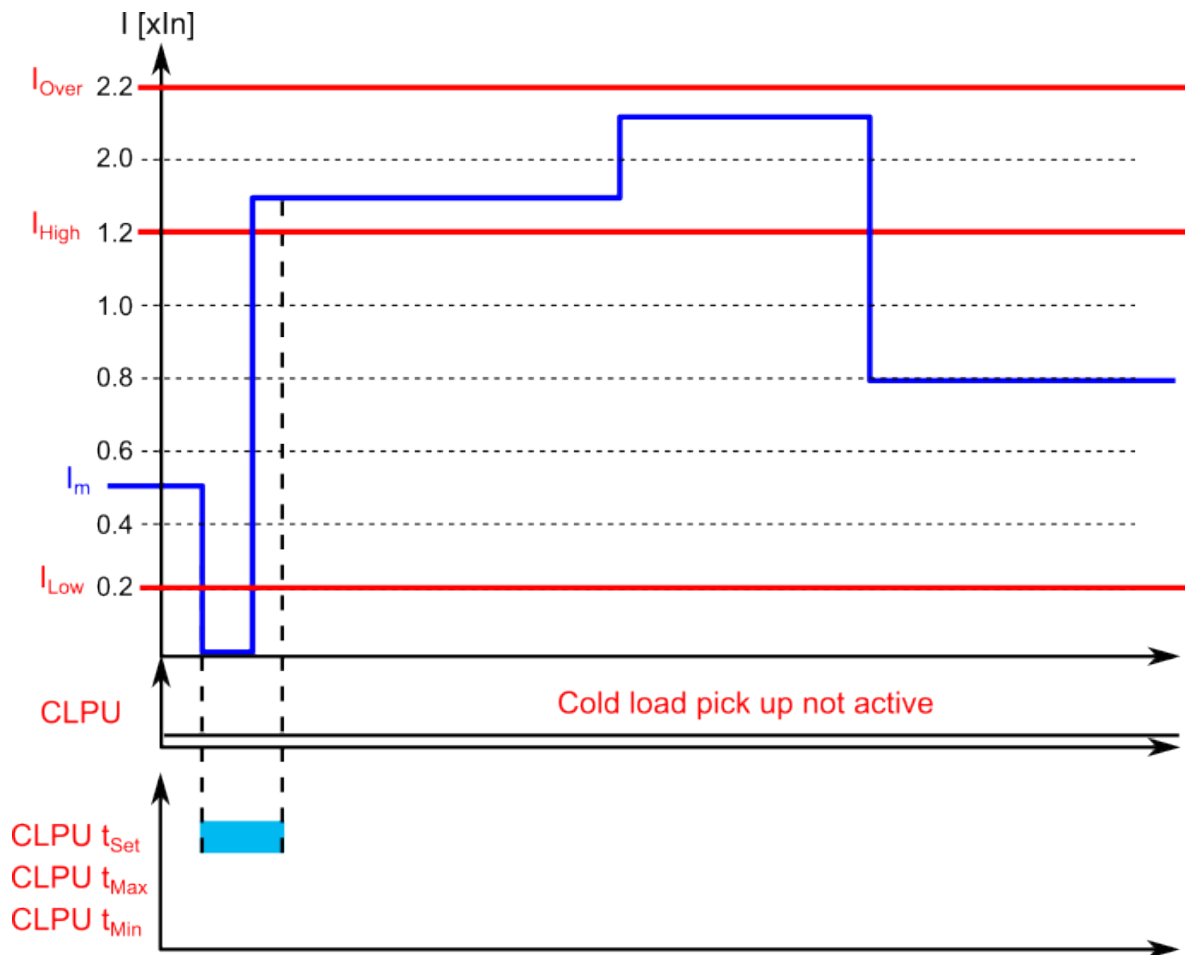

In the example above, the cold load pick-up function does not activate even when the measured current dips below the  $I_{low}$  setting, because the  $T_{set}$  is not exceeded and therefore no cold load pick-up signal is issued. If the user wants the function to activate within a shorter period of time, the  $T_{set}$  parameter can be set to a lower value. If the user wants no delay, the  $T_{set}$  can be zero seconds and the operation will be immediate.

Figure. 4.5.7 - 146. Example of timers and pick-up parameters (activated pick-up and instant release due to overcurrent).

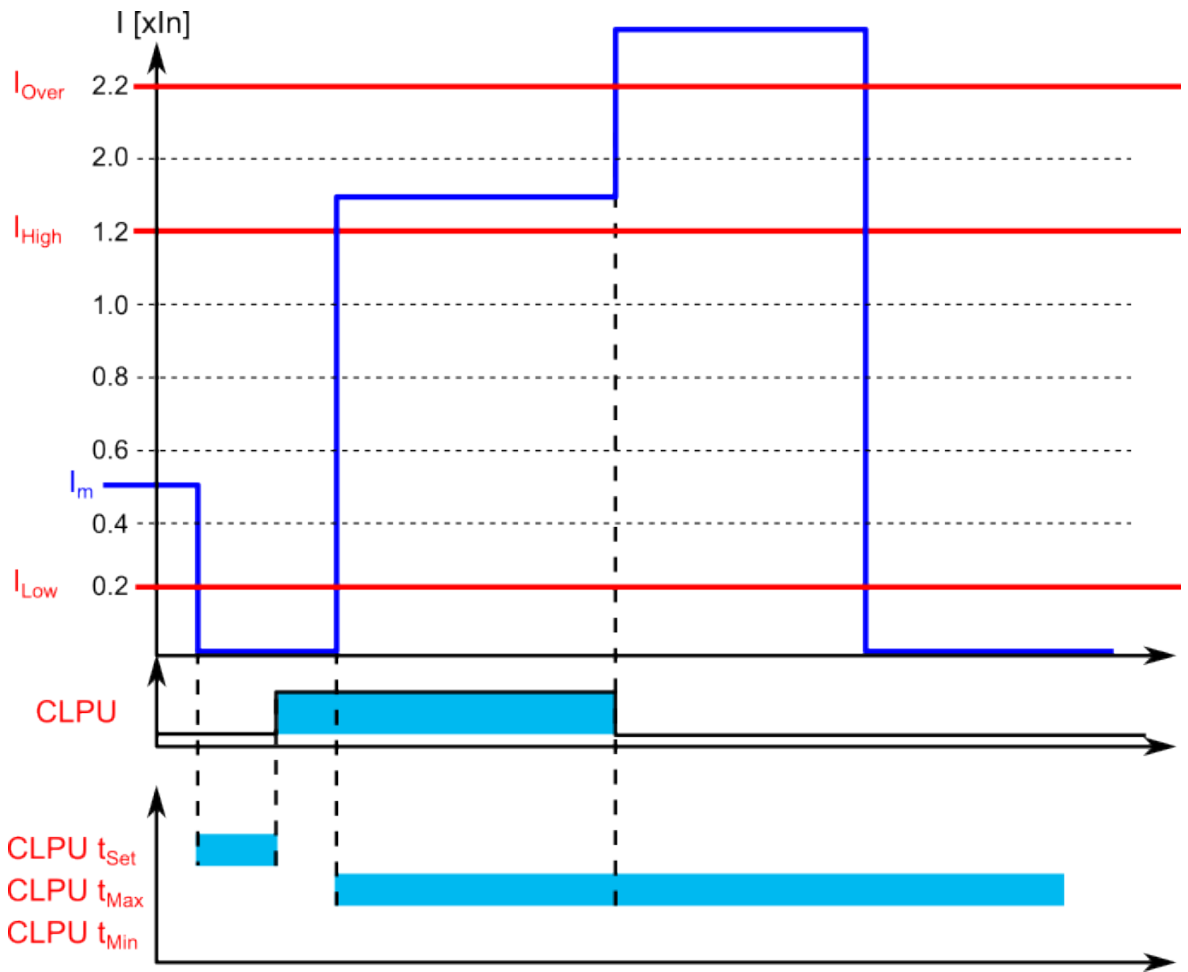

In the example above, the cold load pick-up function activates after the measured current dips below the  $I_{low}$  setting and has been there for  $T_{set}$  amount of time. When the  $I_m$  exceeds the  $I_{high}$  setting, a counter starts counting towards the  $T_{max}$  time. The measured current exceeds the  $I_{over}$  setting during the start-up situation and causes the cold load pick-up signal to be released immediately.

Figure. 4.5.7 - 147. Example of timers and pick-up parameters (activated pick-up and instant release due to too long starting).

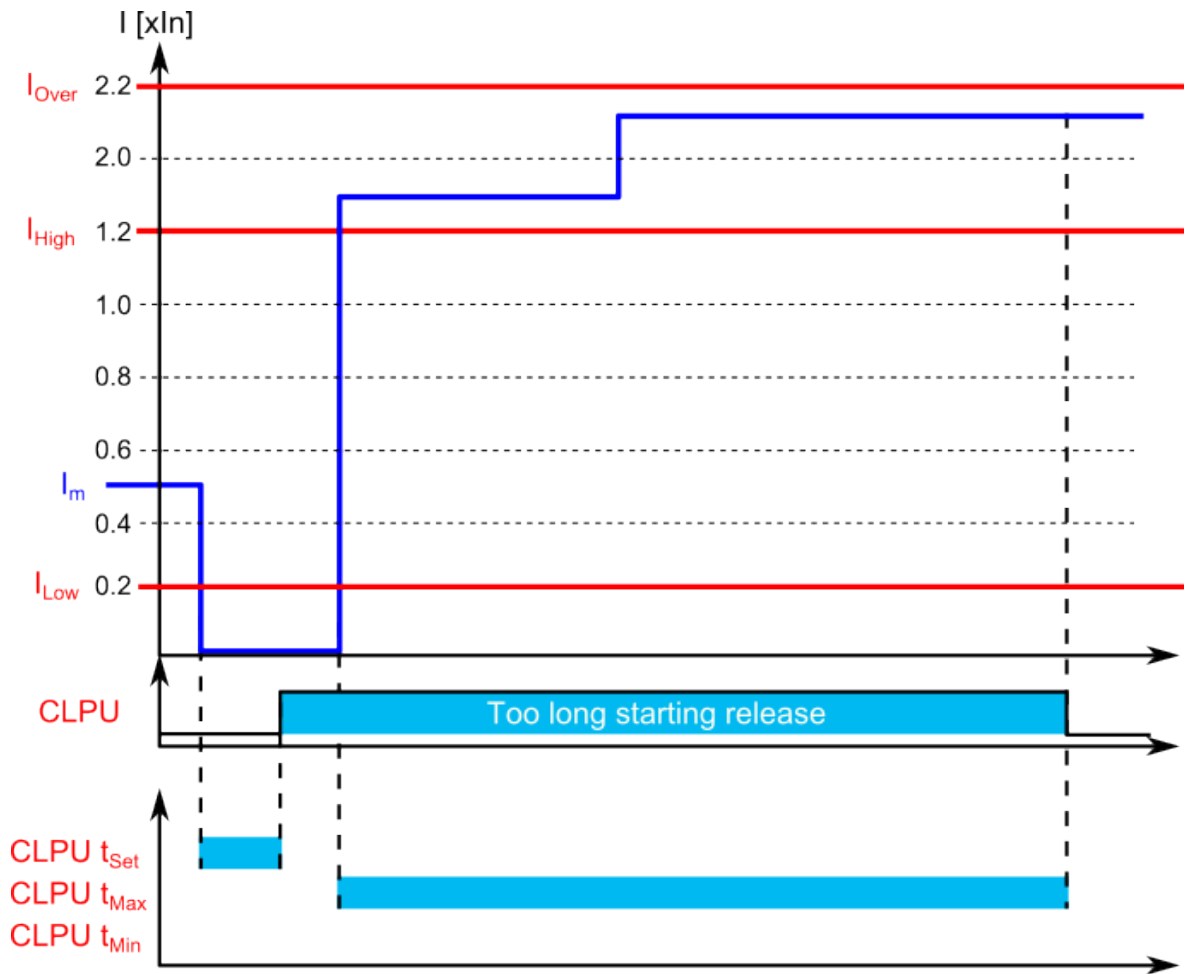

In the example above, the cold load pick-up function activates after the measured current has stayed below the  $I_{low}$  setting for a  $T_{set}$  amount of time. When the current exceeds the  $I_{high}$  setting, a timer starts counting towards the  $T_{max}$  time. The measured current stays above the  $I_{high}$  setting until the  $T_{max}$  is reached, which causes the release of the cold load pick-up signal.

Figure. 4.5.7 - 148. Example of timers and pick-up parameters (no inrush current detected in the starting).

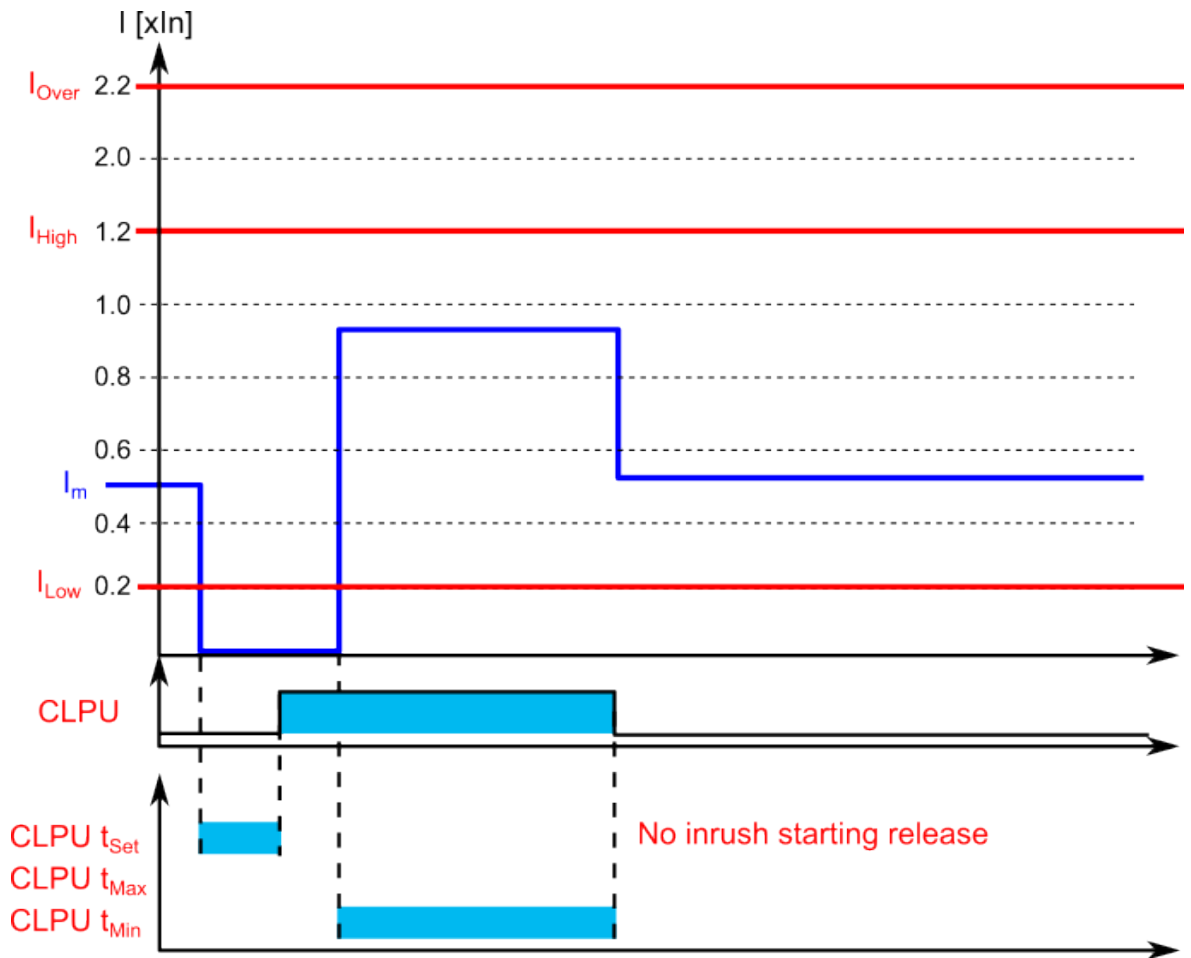

In the example above, the cold load pick-up function activates after the measured current has stayed below the  $I_{Low}$  setting for a  $T_{set}$  amount of time. The current stays between the  $I_{Low}$  setting and the  $I_{High}$  setting, so the cold load pick-up signal is active for  $T_{min}$  time. As no inrush current is detected during that time, the signal is released.

Figure. 4.5.7 - 149. Example of timers and pick-up parameters (an inrush current detected during  $T_{min}$  time).

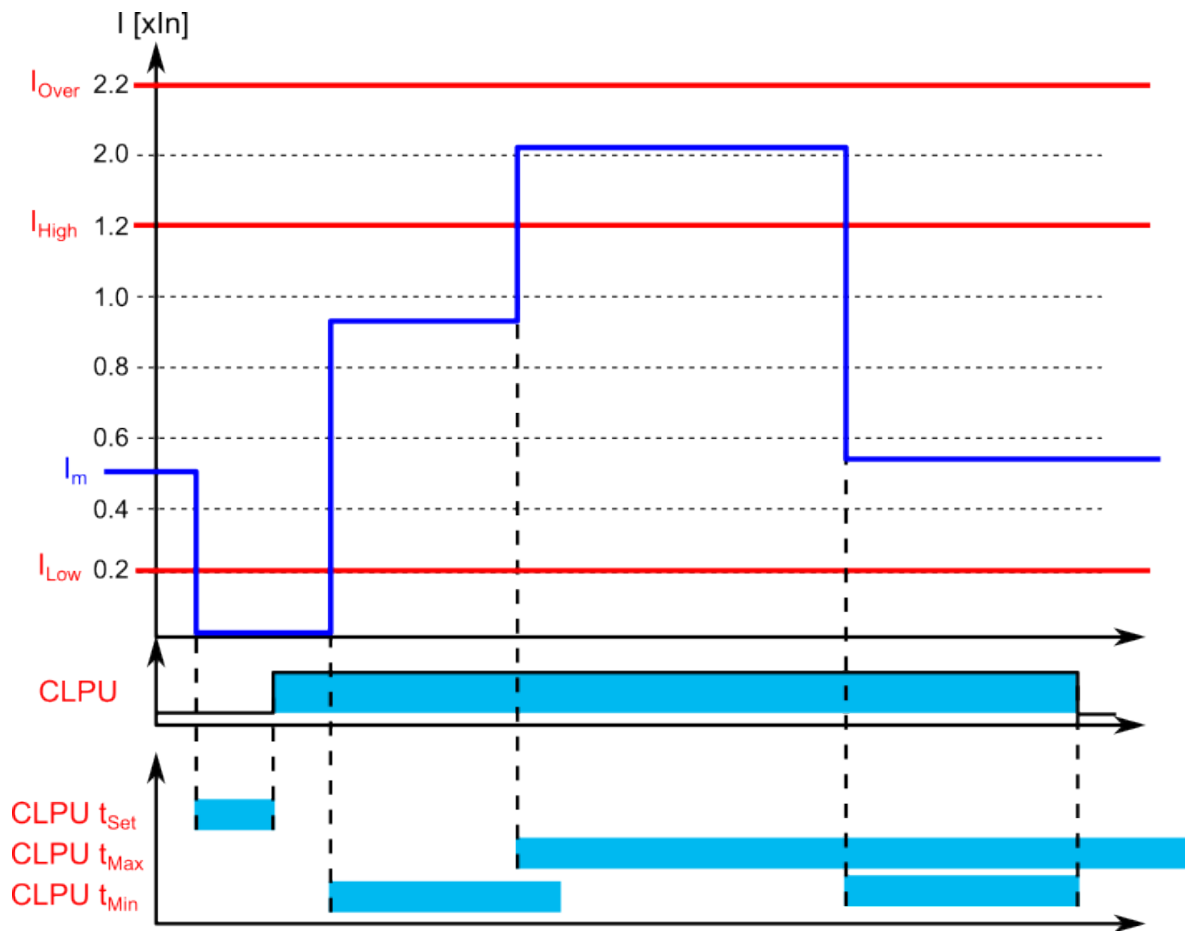

In the example above, the cold load pick-up function activates after the measured current has stayed below the  $I_{low}$  setting for a  $T_{set}$  amount of time. The current increases to between the  $I_{low}$  setting and the  $I_{high}$  setting, which causes a counter to start counting towards the  $T_{min}$  time. Before the counter reaches  $T_{min}$ , the current exceeds the  $I_{high}$  setting, which causes a counter to start counting towards the  $T_{max}$  time. The cold load pick-up signal remains active until the  $T_{max}$  has been reached, or until the start-up is over and the  $T_{min}$  time is over.

### Events and registers

The cold load pick-up function (abbreviated "CLP" in event block names) generates events and registers from the status changes in the events listed below. The user can select which event messages are stored in the main event buffer: ON, OFF, or both. The events triggered by the function are recorded with a time stamp.

The function's outputs can be used for direct I/O controlling and user logic programming. The function also provides a resettable cumulative counter for the CLPU ACT and BLOCKED events.

Table. 4.5.7 - 269. Event messages.

| Event block name | Event names       |
|------------------|-------------------|
| CLP1             | LowStart ON/OFF   |
| CLP1             | HighStart ON/OFF  |
| CLP1             | LoadNormal ON/OFF |

| Event block name | Event names          |
|------------------|----------------------|
| CLP1             | Overcurrent ON/OFF   |
| CLP1             | CLPUActivated ON/OFF |
| CLP1             | Block ON/OFF         |

The function registers its operation into the last twelve (12) time-stamped registers. The register of the function records the ON event process data for ACTIVATED, BLOCKED, etc. The table below presents the structure of the function's register content.

Table. 4.5.7 - 270. Register content.

| Register               | Description   |
|------------------------|---|
| Date and time          | dd.mm.yyyy hh:mm:ss.mss                               |
| Event                  | Event name  |
| L1/L2/L3 current       | Phase currents on trigger time                        |
| Time to CLPUact        | Time remaining before the function is active          |
| CLPU active time       | The time the function has been active before starting |
| Start-up time          | Recorded starting time                                |
| Releasing time of CLPU | Reclaim time counter                                  |
| Setting group in use   | Setting group 1...8 active                            |

## 4.5.8 Switch-on-to-fault (SOTF)

The switch-on-to-fault (SOTF) function is used for speeding up the tripping when the breaker is closed towards a fault or forgotten earthing to reduce the damage in the fault location. The function can be used to control protection functions, or it can be used to directly trip a breaker if any of the connected protection functions starts during the set SOTF time. The operation of the function is instant after the conditions are met and any one signal connected to the "*Function input*" input activates.

The function can be initiated by a digital input, or by a circuit breaker "Close" command connected to the "*SOTF activate input*" input. The duration of the SOTF-armed condition can be set by the "Release time for SOTF" setting parameter; it can be changed if the application so requires through setting group selection.

Figure. 4.5.8 - 150. Simplified function block diagram of the switch-on-to-fault function.

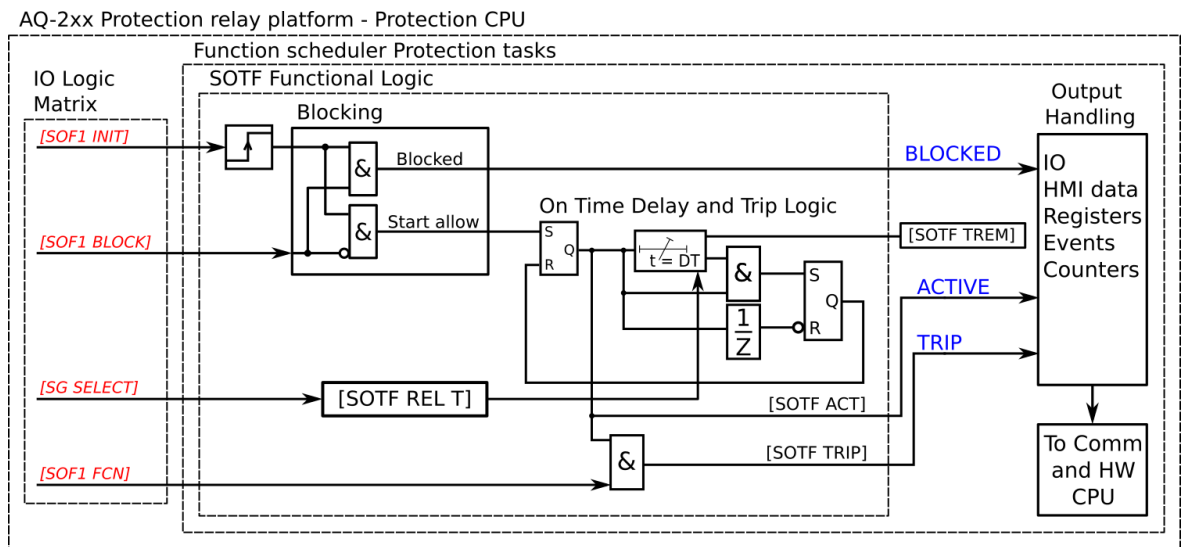

### Input signals

The function block does not use analog measurement inputs. Instead, its operation is based entirely on binary signal statuses.

Table. 4.5.8 - 271. Input signals.

| Input          | Description  |
|----------------|--|
| Activate input | The digital input or logic signal for the function to arm and start calculating the SOTF time. Any binary signal can be used to activate the function and start the calculation. The rising edge of the signal is considered as the start of the function. |
| Block input    | The input for blocking the function. Any binary signal can be used to block the function from starting.  |
| Function input | The function input activates the function's instant trip if applied when the function is calculating the SOTF time.  |

### Settings

The switch-on-to-fault function has one setting and it determines how long the function remains active after it has been triggered. If the inputs receive any of the set signals during this time, the function's trip is activated.

Setting group selection controls the operating characteristics of the function, i.e. the user or user-defined logic can change function parameters while the function is running.

Table. 4.5.8 - 272. Settings of the function.

| Name         | Range  | Default | Description  |
|--------------|--|---------|--|
| SOTF LN mode | <ul style="list-style-type: none"> <li>On</li> <li>Blocked</li> <li>Test</li> <li>Test/Blocked</li> <li>Off</li> </ul> | On      | Set mode of SOF block. This parameter is visible only when <i>Allow setting of individual LN mode</i> is enabled in <i>General</i> menu. |

| Name                  | Range   | Default | Description  |
|-----------------------|---|---------|--|
| SOTF force status to  | <ul style="list-style-type: none"> <li>• Normal</li> <li>• Blocked</li> <li>• Active</li> <li>• Trip</li> </ul> | Normal  | Force the status of the function. Visible only when <i>Enable stage forcing</i> parameter is enabled in <i>General</i> menu. |
| Release time for SOTF | 0.000...1800.000s   | 1.000s  | The time the function is active after triggering.  |

### Read-only parameters

The function's *Info* page displays useful, real-time information on the state of the protection function. It is accessed either through the device's HMI display, or through the setting tool software when it is connected to the device and its Live Edit mode is active.

Table. 4.5.8 - 273. Information displayed by the function.

| Name              | Range  | Description   |
|-------------------|--|---|
| SOTF LN behaviour | <ul style="list-style-type: none"> <li>• On</li> <li>• Blocked</li> <li>• Test</li> <li>• Test/Blocked</li> <li>• Off</li> </ul> | Displays the mode of SOTF block.<br>This parameter is visible only when <i>Allow setting of individual LN mode</i> is enabled in <i>General</i> menu. |
| SOTF condition    | <ul style="list-style-type: none"> <li>• Normal</li> <li>• Init</li> <li>• Active</li> <li>• Trip</li> <li>• Blocked</li> </ul>  | Displays status of the control function.  |

### Function blocking

The function can be blocked by activating the BLOCK input. This prevents the function's active time from starting.

### Events and registers

The switch-on-to-fault function (abbreviated "SOF" in event block names) generates events and registers from the status changes in the events listed below. The user can select which event messages are stored in the main event buffer: ON, OFF, or both. The events triggered by the function are recorded with a time stamp.

The function's outputs can be used for direct I/O controlling and user logic programming. The function also provides a resettable cumulative counter for the INIT, BLOCKED, ACTIVE and TRIP events.

Table. 4.5.8 - 274. Event messages.

| Event block name | Event names       |
|------------------|-------------------|
| SOF1             | SOTF Init ON/OFF  |
| SOF1             | SOTF Block ON/OFF |

| Event block name | Event names        |
|------------------|--------------------|
| SOF1             | SOTF Active ON/OFF |
| SOF1             | SOTF Trip ON/OFF   |

The function registers its operation into the last twelve (12) time-stamped registers. The register of the function records the ON process data of ACTIVATED events. The table below presents the structure of the function's register content.

Table. 4.5.8 - 275. Register content.

| Register              | Description                                 |
|-----------------------|---|
| Date and time         | dd.mm.yyyy hh:mm:ss.mss                     |
| Event                 | Event name                                  |
| Used SG               | Setting group 1...8 active                  |
| SOTF remaining time   | The time remaining of the set release time. |
| SOTF been active time | The time the function has been active.      |

### 4.5.9 Vector jump ( $\Delta\phi$ ; 78)

Distribution systems may include different kinds of distributed power generation sources, such as wind farms and diesel or fuel generators. When a fault occurs in the distribution system, it is usually detected and isolated by the protection system closest to the faulty point, resulting in the electrical power system shutting down either partially or completely. The remaining distributed generators try to deliver the power to the part of the distribution system that has been disconnected from the grid, and usually an overload condition can be expected. Under such overload conditions, it is normal to have a drop in voltage and frequency. This overload results in the final system disconnection from the islanding generator(s). The disconnection depends greatly on the ratio between the power generation and the demand of the islanded system. When any power is supplied to a load only from distributed generators, (due to the opening of the main switch), the situation is called an isolated island operation or an islanded operation of the electrical distribution network.

The vector jump control function is suitable to detect most islanding situations and to switch off the mains breaker in order to let the generator only supply loads according to their rated power value. Therefore, an overload does not cause any mechanical stress to the generator unit(s). The vector jump function should be located either on the mains side of the operated breaker or on the islanding generator side.

The vector jump function is used for instant tripping and has only one operating stage. The function has an algorithm which follows the samples of chosen measured voltages (64 samples/cycle). The reference voltage used can be all or any of the phase-to-phase or phase-to-neutral voltages.

Figure. 4.5.9 - 151. Simplified function block diagram of the  $\Delta\phi$  function.

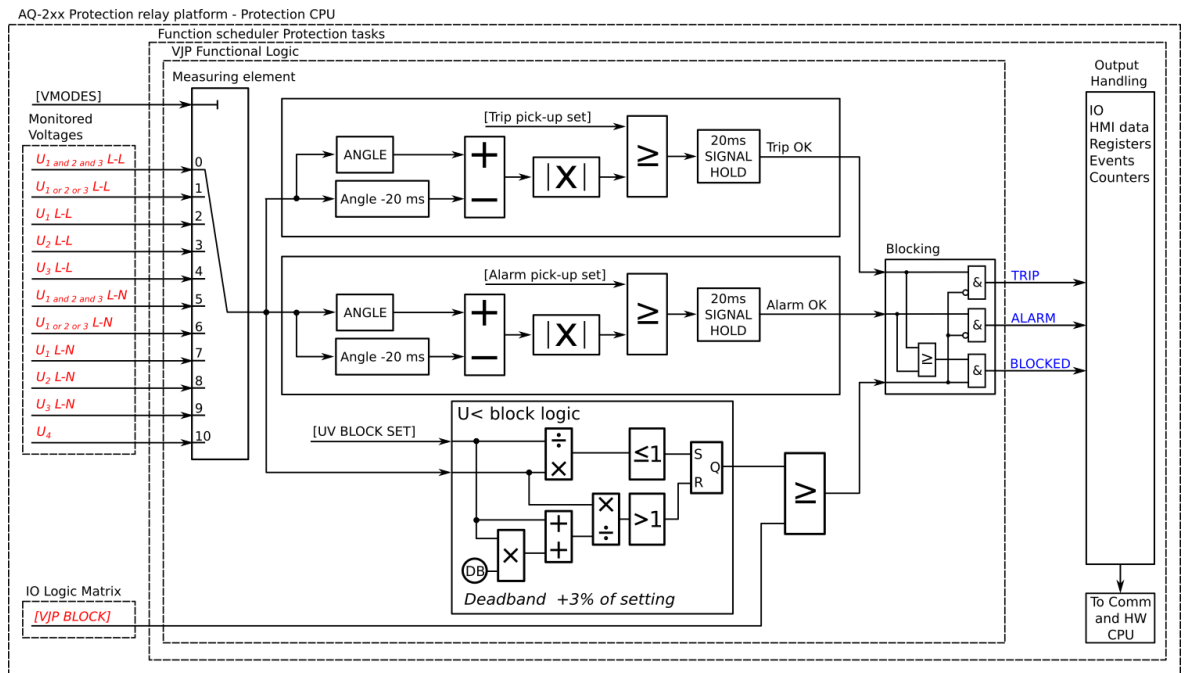

### Measured input

The function block uses phase-to-phase or phase-to-neutral voltages and always uses complex measurement from samples.

Table. 4.5.9 - 276. Measurement inputs of the vector jump function.

| Signal               | Description   |
|----------------------|---|
| U <sub>1</sub> CMLPX | The complex vector of U <sub>1</sub> /V voltage channel |
| U <sub>2</sub> CMLPX | The complex vector of U <sub>2</sub> /V voltage channel |
| U <sub>3</sub> CMLPX | The complex vector of U <sub>3</sub> /V voltage channel |
| U <sub>4</sub> CMLPX | The complex vector of U <sub>4</sub> /V voltage channel |

### Pick-up settings

Setting group selection controls the operating characteristics of the function, i.e. the user or user-defined logic can change function parameters while the function is running.

When a fault appears in the power system and some areas are disconnected, normally the remaining generators connected to the network must supply the area disconnected from the utility side supply. This results in an instantaneous demand of power that the generators must tackle. The excitation and the mechanical systems cannot answer such a huge demand of power quickly even if there were enough reserve power. The worst of the situation is received by the rotors of the generator units: they suffer a torsion torque that can even break the rotor and cause subsequent damage not only for the generator but for the entire power plant too.

Figure. 4.5.9 - 152. Generator islanding.

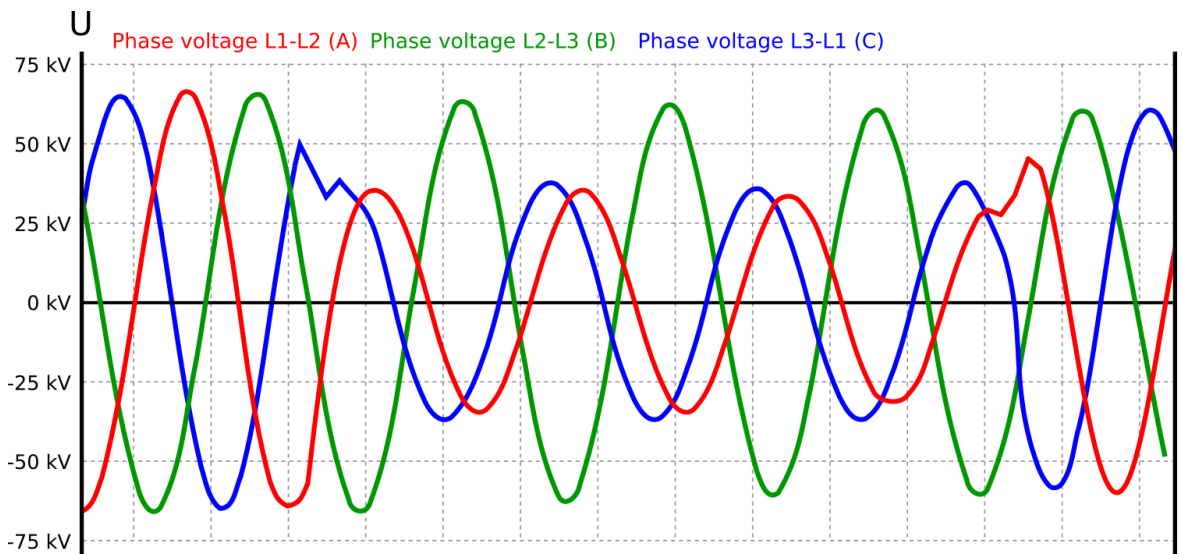

As can be seen in the example above, only phase-to-phase voltages L1-L2 and L3-L1 have been reduced, while voltage L2-L3 remains the same. This means that the problem occurred in phase L1 of the network. The voltage level is not reduced to zero, nor is the voltage in any phase is totally lost. The phases without the fault condition remain normal with the same value. On the other hand, the frequency can sag as can be seen in the figure above.

The  $\Delta\alpha$  setting parameter controls the pick-up of the vector jump function. This defines the minimum allowed rapid measured voltage angle change before action from the function. The function constantly calculates the ratio between the  $\Delta\alpha_{set}$  and the measured magnitude ( $\Delta\alpha_m$ ) for each of the selected voltages. The function's stage trip signal lasts for 20 ms and automatically resets after that time has passed. The setting value is common for all measured amplitudes.

Figure. 4.5.9 - 153. Vector jump from the function's point of view.

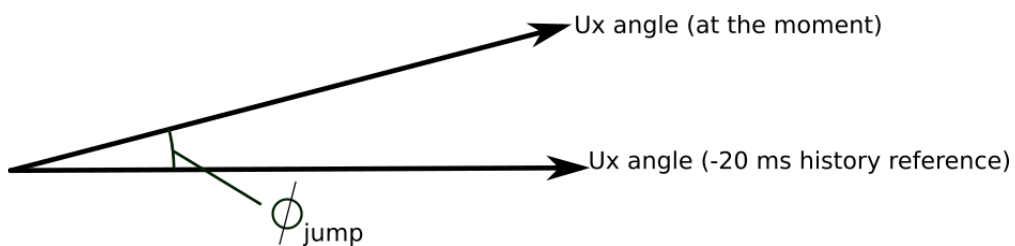

The following general settings define the general behavior of the function. These settings are static i.e. it is not possible to change them by editing the setting group.

Table. 4.5.9 - 277. General settings of the function.

| Name                   | Range  | Default | Description  |
|------------------------|--|---------|--|
| $\Delta\alpha$ LN mode | <ul style="list-style-type: none"> <li>• On</li> <li>• Blocked</li> <li>• Test</li> <li>• Test/Blocked</li> <li>• Off</li> </ul> | On      | Set mode of VJP block. This parameter is visible only when <i>Allow setting of individual LN mode</i> is enabled in <i>General</i> menu. |

| Name                           | Range   | Default                | Description  |
|--------------------------------|---|------------------------|--|
| $\Delta\alpha$ force status to | <ul style="list-style-type: none"> <li>• Normal</li> <li>• Blocked</li> <li>• Trip</li> <li>• Alarm</li> </ul>  | Normal                 | Force the status of the function. Visible only when <i>Enable stage forcing</i> parameter is enabled in <i>General</i> menu. |
| Available stages               | <ul style="list-style-type: none"> <li>• Trip</li> <li>• Trip and alarm</li> </ul>  | Trip                   | Defines if alarm is included with trip or not.   |
| Monitored voltages             | <ul style="list-style-type: none"> <li>• System all P-P Voltages</li> <li>• System any P-P Voltage</li> <li>• System L12 Voltage</li> <li>• System L23 Voltage</li> <li>• System L31 Voltage</li> <li>• System all P-E voltages</li> <li>• System any P-E voltage</li> <li>• System L1 Voltage</li> <li>• System L2 Voltage</li> <li>• System L3 Voltage</li> <li>• U4 Voltage</li> </ul> | System any P-P Voltage | Defines the monitored voltage channel(s)   |

Table. 4.5.9 - 278. Pick-up settings.

| Name   | Range                | Step        | Default   | Description   |
|--|----------------------|-------------|-----------|---|
| Pick-up setting $\Delta\alpha$ (lead or lag) Trip  | 0.05...30.00°        | 0.01°       | 5°        | Pick-up setting for trip signal   |
| Pick-up setting $\Delta\alpha$ (lead or lag) Alarm | 0.05...30.00°        | 0.01°       | 5°        | Pick-up setting for alarm signal  |
| Undervoltage block limit % < $U_n$                 | 0.01...100.00% $U_n$ | 0.01% $U_n$ | 95% $U_n$ | Block setting. When measured voltage is below this setting the function is blocked. |

### Read-only parameters

The function's *Info* page displays useful, real-time information on the state of the protection function. It is accessed either through the device's HMI display, or through the setting tool software when it is connected to the device and its Live Edit mode is active.

Table. 4.5.9 - 279. Information displayed by the function.

| Name  | Range  | Step     | Description  |
|---|--|----------|--|
| $\Delta\alpha > \text{LN}$ behaviour        | <ul style="list-style-type: none"> <li>On</li> <li>Blocked</li> <li>Test</li> <li>Test/Blocked</li> <li>Off</li> </ul> | -        | Displays the mode of UEX block.<br>This parameter is visible only when <i>Allow setting of individual LN mode</i> is enabled in <i>General</i> menu. |
| $\Delta\alpha > \text{condition}$           | <ul style="list-style-type: none"> <li>Normal</li> <li>Blocked</li> <li>Trip</li> <li>Alarm</li> </ul>                 | -        | Displays status of the protection function.  |
| Voltage meas selected                       | <ul style="list-style-type: none"> <li>Selection Ok</li> <li>Selection not available</li> </ul>                        | -        | Displays validity of the voltage channel(s) selected in "Monitored voltages" parameter.  |
| $\Delta\alpha > \text{U1 Angle difference}$ | -360...360deg  | 0.01deg  | Displays the angle difference between present time and 20 ms ago.  |
| $\Delta\alpha > \text{U2 Angle difference}$ |  |          |  |
| $\Delta\alpha > \text{U3 Angle difference}$ |  |          |  |
| $\Delta\alpha > \text{U1meas/set}$          | -360...360p.u.   | 0.01p.u. | Displays the ratio between the measured voltage and undervoltage block limit setting.  |
| $\Delta\alpha > \text{U2meas/set}$          |  |          |  |
| $\Delta\alpha > \text{U3meas/set}$          |  |          |  |

## Function blocking

The blocking signal is evaluated at the start of each program cycle. The blocking signals are connected to the function's dedicated input, which can be configured in the *IO* → *Blocking Input Control* tab of the function.

- When the pick-up element activates and the blocking signal is not active, a ALARM or TRIP signal is generated, and the function starts or continues with the trip time countdown.
- When the pick-up element activates and the blocking signal is active, a BLOCKED signal is generated, and the function does not process the event further.
- When an ALARM or TRIP signal is already active and the blocking input signal becomes active, the signal is reset and BLOCKED signal is generated. The release time characteristics are then processed in the same way as when the pick-up signal is reset.

The blocking signal needs to reach the device minimum of 5 ms before the set operating delay has passed in order for the blocking to activate in time.

## Events and registers

The vector jump function (abbreviated "VJP" in event block names) generates events and registers from the status changes in the events listed below. The user can select which event messages are stored in the main event buffer: ON, OFF, or both. The events triggered by the function are recorded with a time stamp.

The function's outputs can be used for direct I/O controlling and user logic programming. The function also provides a resettable cumulative counter for the ALARM, TRIP and BLOCKED events.

Table. 4.5.9 - 280. Event messages.

| Event block name | Event names  |
|------------------|--------------|
| VJP1             | Block ON/OFF |
| VJP1             | Trip ON/OFF  |
| VJP1             | Alarm ON/OFF |

The function registers its operation into the last twelve (12) time-stamped registers. The register of the function records the ON event process data for ALARM, TRIP or BLOCKED. The table below presents the structure of the function's register content.

Table. 4.5.9 - 281. Register content.

| Register                            | Description                |
|-------------------------------------|----------------------------|
| Date and time                       | dd.mm.yyyy hh:mm:ss.mss    |
| Event                               | Event name                 |
| Fault type                          | L1(2), L2(3), L3(1) and U4 |
| Trip $\Delta\alpha$ meas / dataset  | Trip angle difference      |
| Alarm $\Delta\alpha$ meas / dataset | Alarm angle difference     |
| Setting group in use                | Setting group 1...8 active |

### 4.5.10 Synchrocheck ( $\Delta V/\Delta a/\Delta f$ ; 25)

Checking the synchronization is important to ensure the safe closing of the circuit breaker between two systems. Closing the circuit breaker when the systems are not synchronized can cause several problems such as current surges which damage the interconnecting elements. The synchrocheck function has three stages: SYN1, SYN2 and SYN3. Their function and availability of these stages depend on which voltage channels are set to "SS" mode or not. Voltage measurement settings are located at *Measurements* → *Transformers* → *VT module*. When synchroswitching is used, the function automatically closes the breaker when both sides of the breaker are synchronized.

When only U3 or U4 voltage measurement channel has been set to "SS" mode:

- SYN1 – Supervises the synchronization condition between the channel set to "SS" mode and the selected system voltage (UL1, UL2, UL3, UL12, UL23 or UL31).
- SYN2 – Not active and not visible.
- SYN3 – Not active and not visible.

When both U3 and U4 have been set to "SS" mode:

- SYN1 – Supervises the synchronization condition between the U3 channel and the selected system voltage (UL12, UL23 or UL31).
- SYN2 – Supervises the synchronization condition between the U4 channel and the selected system voltage (UL12, UL23 or UL31).
- SYN3 – Supervises the synchronization condition between the channels U3 and U4.

The seven images below present three different example connections and four example applications of the synchrocheck function.

Figure. 4.5.10 - 154. Example connection of the synchrocheck function (3LN+U4 mode, SYN1 in use, UL1 as reference voltage).

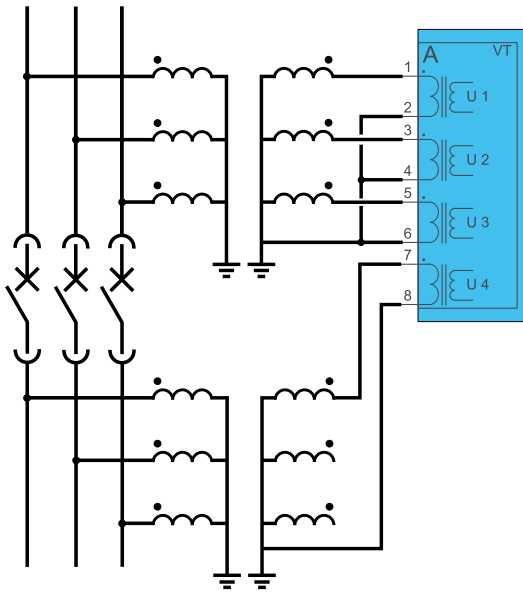

Figure. 4.5.10 - 155. Example connection of the synchrocheck function (2LL+U0+U4 mode, SYN1 in use, UL12 as reference voltage).

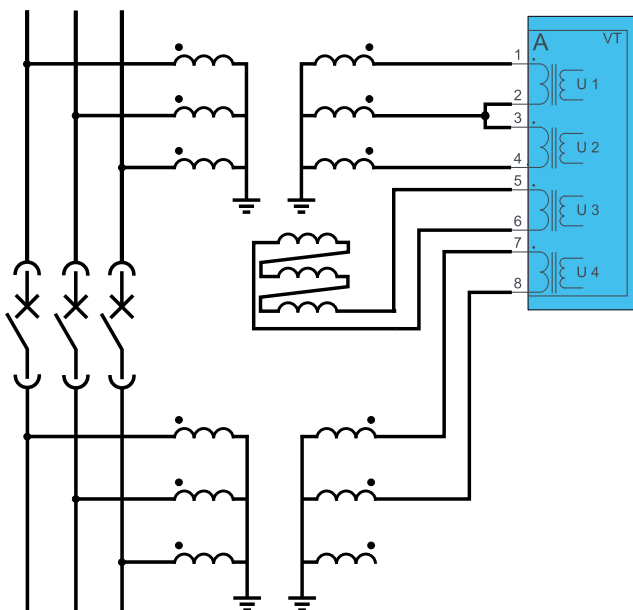

Figure. 4.5.10 - 156. Example connection of the synchrocheck function (2LL+U3+U4 mode, SYN3 in use, UL12 as reference voltage).

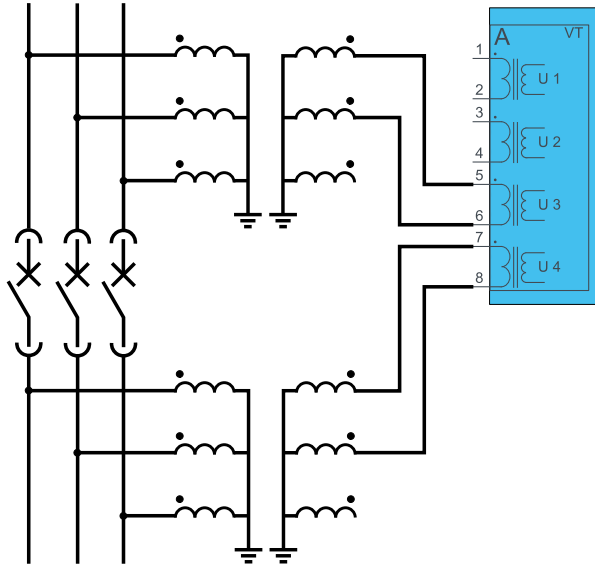

Figure. 4.5.10 - 157. Example application (synchrocheck over one breaker, with 3LL and 3LN VT connections).

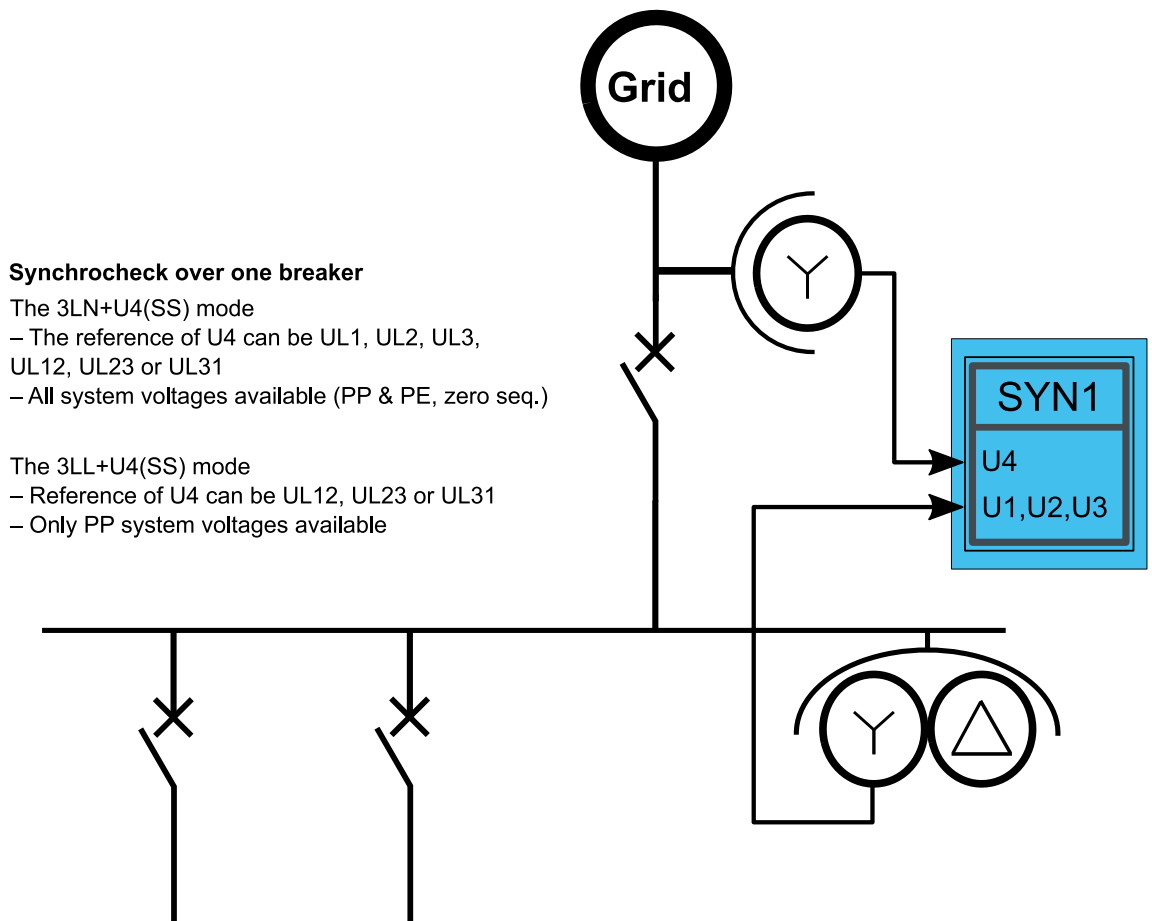

Figure. 4.5.10 - 158. Example application (synchrocheck over one breaker, with 2LL VT connection).

**Synchrocheck over one breaker**

Mode 2LL+U3(U0)+U4(SS)

– Reference of U4 can be UL1, UL2,

UL3, UL12, UL23 or UL31

– All system voltages available  
(PP & PE, zero seq.)

Figure. 4.5.10 - 159. Example application (synchrocheck over two breakers, with 2LL VT connection).

## Synchrocheck over two breakers

Mode 2LL+U3(SS)+U4(SS)

- Reference of U3 and U4 can be UL12, UL23 or UL31
- PP system voltages available

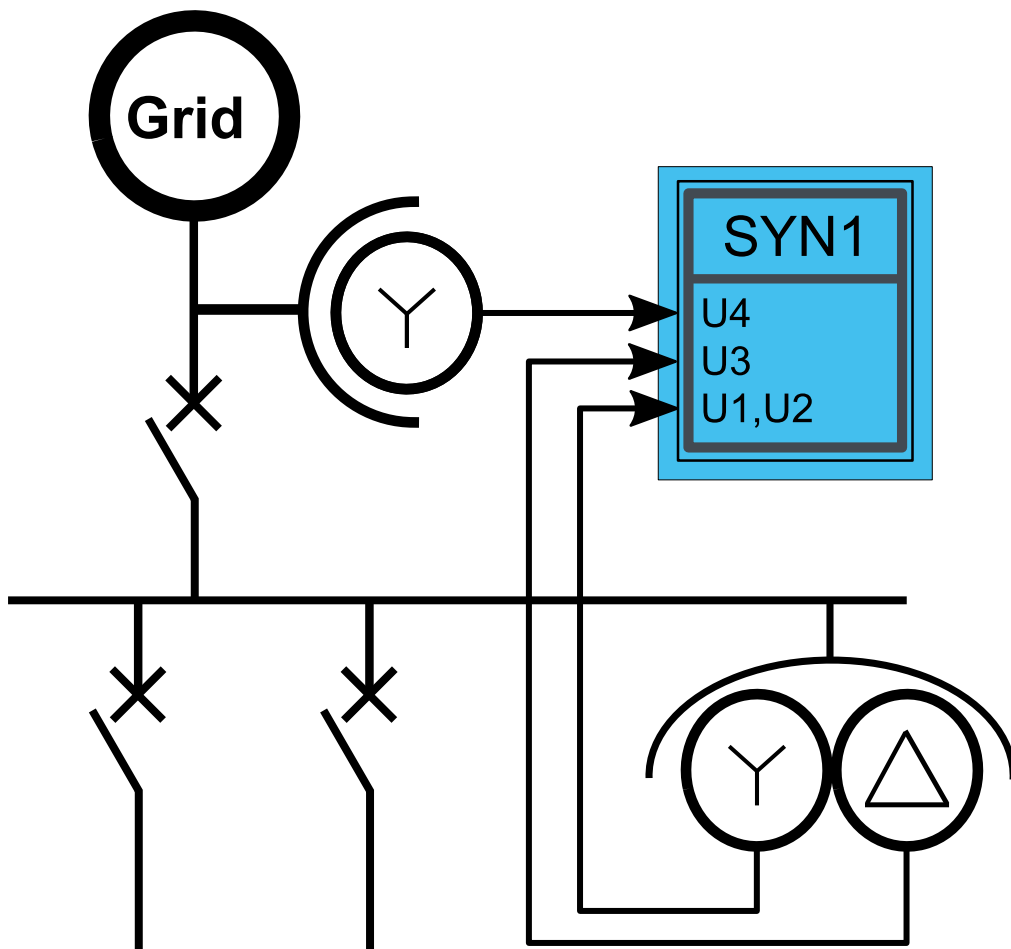
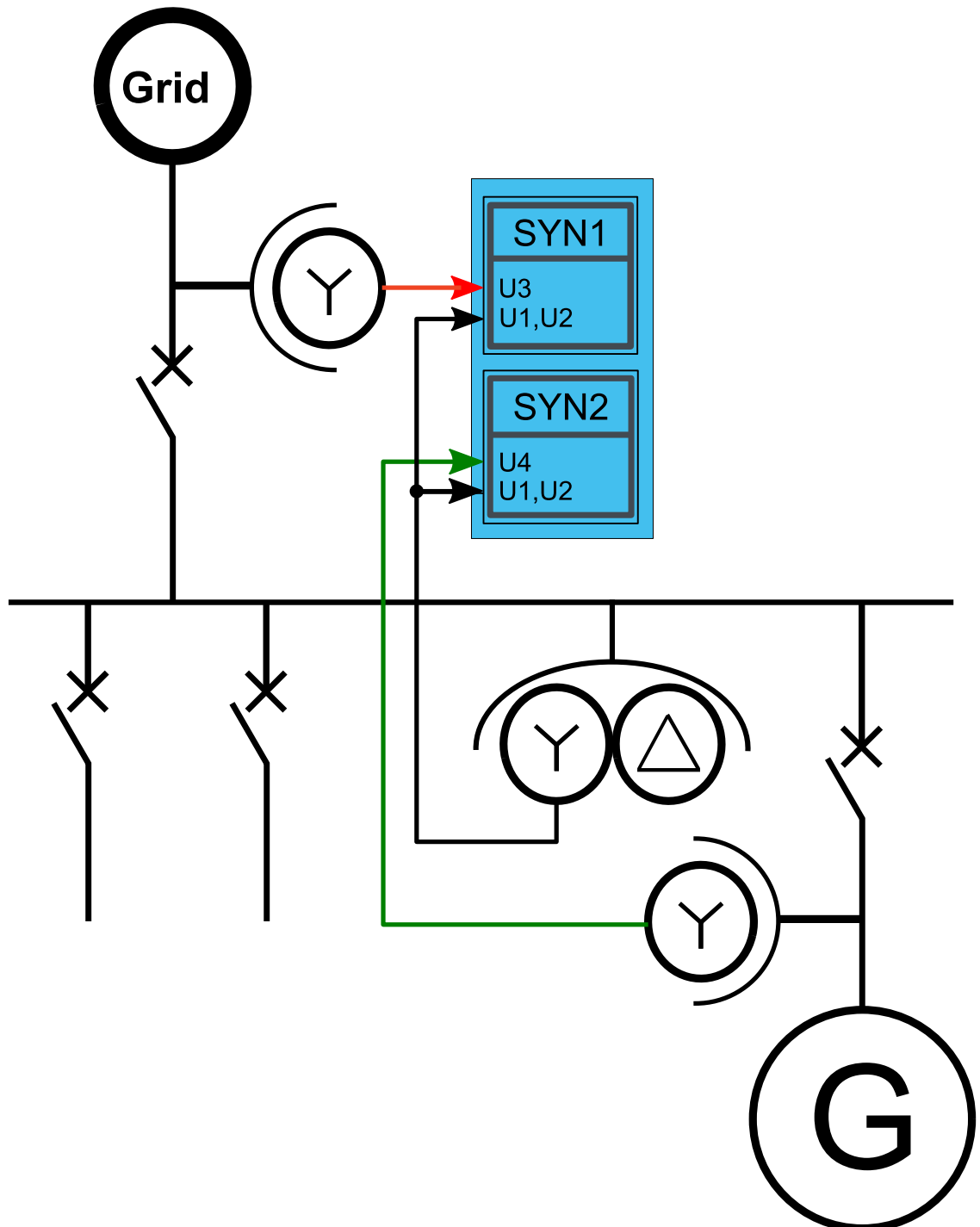
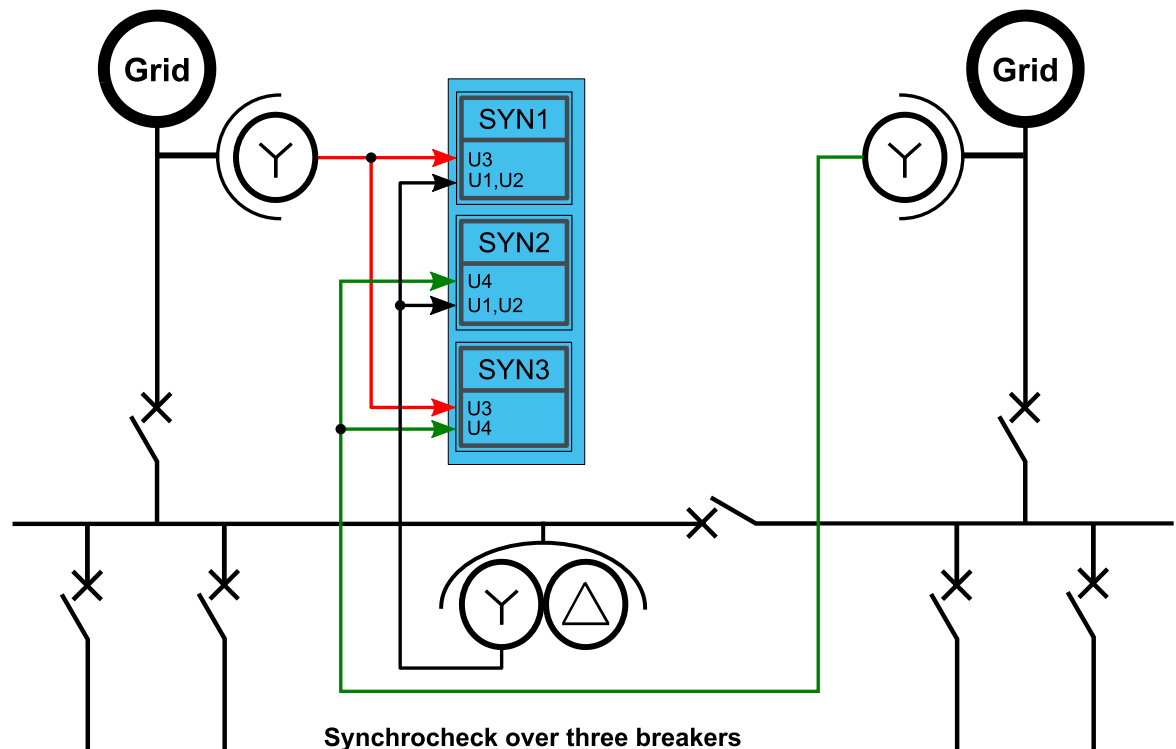

Figure. 4.5.10 - 160. Example application (synchrocheck over three breakers, with 2LL+U3+U4 connection).

**Synchrocheck over three breakers**

Mode 2LL+U3(SS)+U4(SS)

– Reference of U3 and U4 can be UL12, UL23 or UL31.

U3 and U4 References must be the same

– PP system voltages available

**NOTICE!**

When synchrocheck is used over three breakers, SYN1 and SYN2 must have the same reference voltage.

The following aspects of the compared voltages are used in synchrocheck:

- voltage magnitudes
- voltage frequencies
- voltage phase angles

The two systems are synchronized when these three aspects are matched. All three cannot, of course, ever be exactly the same so the function requires the user to set the maximum difference between the measured voltages.

Depending on how the measured voltage compares to the set  $U_{live}$  and  $U_{dead}$  parameters, either system can be in a "live" or a "dead" state. The parameter  $SYN_x U_{conditions}$  is used to determine the conditions (in addition to the three aspects) which are required for the systems to be considered synchronized.

The image below shows the different states the systems can be in.

Figure. 4.5.10 - 161. System states.

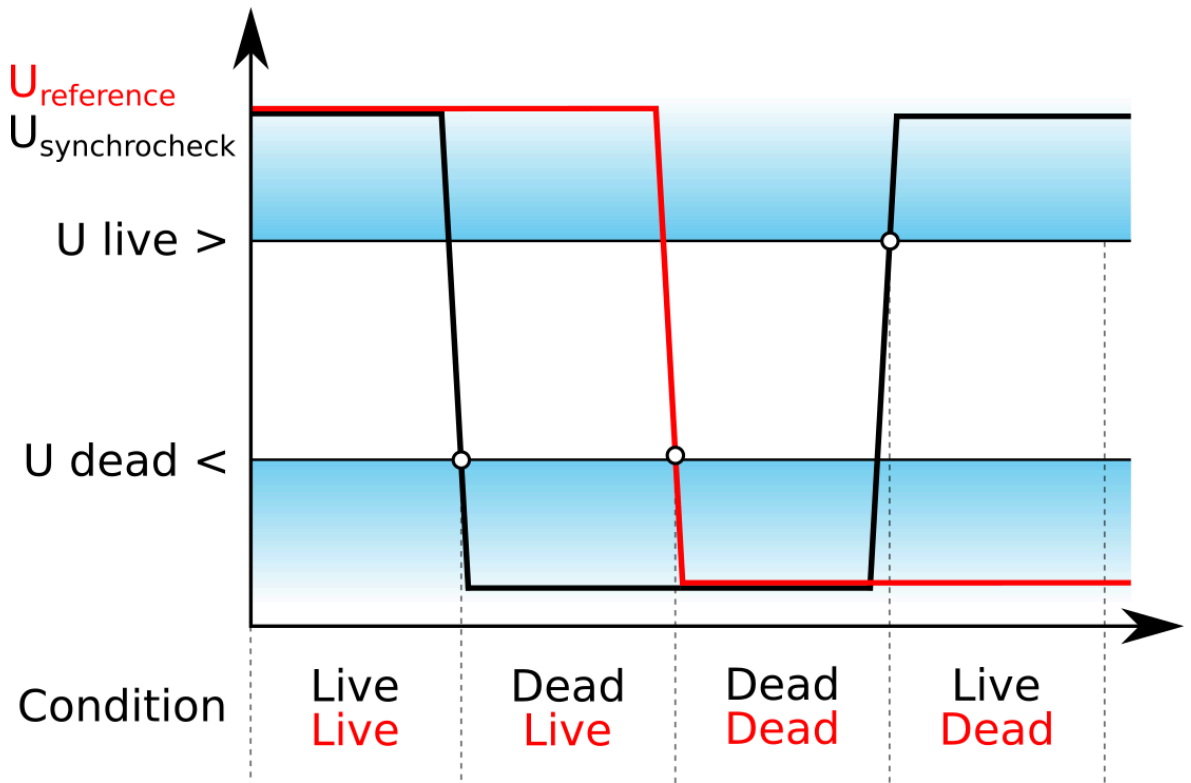

Figure. 4.5.10 - 162. Simplified function block diagram of the SYN1 and SYN2 function.

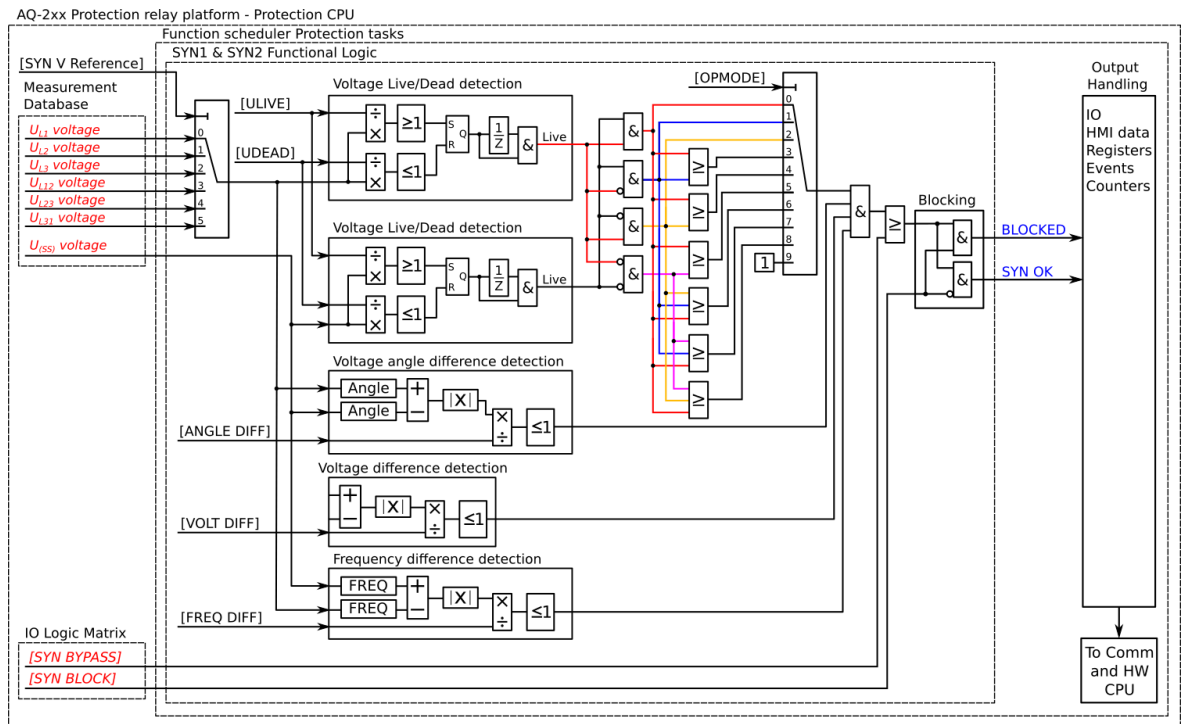
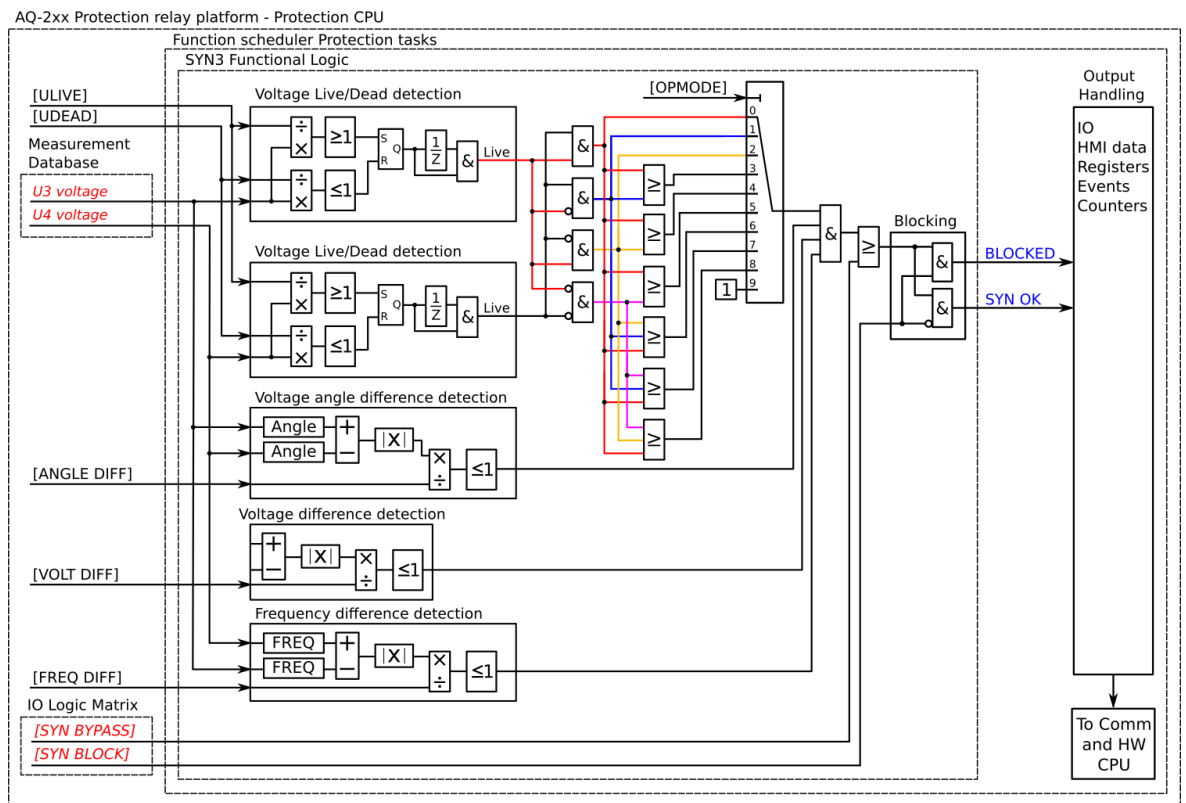

Figure. 4.5.10 - 163. Simplified function block diagram of the SYN3 function.



### Measured input

The function block uses user selected voltage channels. The function monitors frequency, angle and fundamental frequency component value of the selected channels.

Table. 4.5.10 - 282. Measurement inputs of the synchrocheck function.

| Signal             | Description  |
|--------------------|--|
| U <sub>1</sub> RMS | Fundamental frequency component of U <sub>1</sub> /V voltage channel |
| U <sub>2</sub> RMS | Fundamental frequency component of U <sub>2</sub> /V voltage channel |
| U <sub>3</sub> RMS | Fundamental frequency component of U <sub>3</sub> /V voltage channel |
| U <sub>4</sub> RMS | Fundamental frequency component of U <sub>4</sub> /V voltage channel |

### Read-only parameters

The function's *Info* page displays useful, real-time information on the state of the protection function. It is accessed either through the device's HMI display, or through the setting tool software when it is connected to the device and its Live Edit mode is active.

Table. 4.5.10 - 283. Information displayed by the function.

| Name                       | Range  | Step     | Description  |
|----------------------------|--|----------|--|
| dV / da / df LN behaviour  | <ul style="list-style-type: none"> <li>• On</li> <li>• Blocked</li> <li>• Test</li> <li>• Test/Blocked</li> <li>• Off</li> </ul>   | -        | Displays the mode of SYN block.<br>This parameter is visible only when <i>Allow setting of individual LN mode</i> is enabled in <i>General</i> menu. |
| SYN condition              | <ul style="list-style-type: none"> <li>• SYN1 Blocked</li> <li>• SYN1 Ok</li> <li>• SYN1 Bypass</li> <li>• SYN1 Vcond Ok</li> <li>• SYN1 Vdiff Ok</li> <li>• SYN1 Adiff Ok</li> <li>• SYN1 fdiff Ok</li> </ul> | -        | Displays status of the control function.   |
| SYN volt status            | <ul style="list-style-type: none"> <li>• Dead Dead</li> <li>• Live Dead</li> <li>• Dead Live</li> <li>• Live Live</li> <li>• Undefined</li> <li>• Not monitored</li> </ul>                                     | -        | Displays the voltage status of both sides.   |
| SYN Mag diff               | -120...120%Un  | 0.01%Un  | Displays voltage difference between the two measured voltages.   |
| SYN Ang diff               | -360'...360deg   | 0.01deg  | Displays angle difference between the two measured voltages.   |
| SYN Freq diff              | -75...75Hz   | 0.001Hz  | Displays frequency difference between the two measured voltages.   |
| SYN Switch status          | <ul style="list-style-type: none"> <li>• Still</li> <li>• Departing</li> <li>• Enclosing</li> </ul>  | -        | Displays the synchroswitching status.<br>This parameter is visible when "SYN Switching" parameter has been set to "Use SynSW".                       |
| Estimated BRK closing time | 0...360s   | 0.005s   | Estimated time left to breaker closing.  |
| Networks rotating time     | 0...360s   | 0.005s   | Estimated time how long it takes for the network to rotate fully.  |
| Networks placement atm     | -360...360deg  | 0.001deg | Networks placement in degrees.   |

### Function blocking

The block signal is checked in the beginning of each program cycle. The blocking signal is received from the blocking matrix in the function's dedicated input. If the blocking signal is not activated when the synchronization is OK, a SYN OK signal is generated.

If the blocking signal is active when the SYN OK activates, a BLOCKED signal is generated and the function does not process the situation further. If the SYN OK function has been activated before the blocking signal, it resets.

## Setting parameters

**NOTE!** Before these settings can be accessed, a voltage channel (U3 or U4) must be set into the synchrocheck mode ("SS") in the voltage transformer settings (*Measurements* → *VT Module*).

The general settings can be found at the synchrocheck function's *INFO* tab, while the synchrocheck stage settings can be found in the *Settings* tab (*Control* → *Control functions* → *Synchrocheck*).

Table. 4.5.10 - 284. General settings.

| Name  | Range   | Step    | Default                | Description   |
|---|---|---------|------------------------|---|
| dV / da / df<br>LN mode                     | <ul style="list-style-type: none"> <li>On</li> <li>Blocked</li> <li>Test</li> <li>Test/Blocked</li> <li>Off</li> </ul>  | -       | On                     | Set mode of SYN block.<br>This parameter is visible only when <i>Allow setting of individual LN mode</i> is enabled in <i>General</i> menu.   |
| SYN(1,2,3)<br>Status<br>Force to            | <ul style="list-style-type: none"> <li>Normal</li> <li>SYN1 Blocked</li> <li>SYN1 Ok</li> <li>SYN2 Blocked</li> <li>SYN2 Ok</li> <li>SYN3 Blocked</li> <li>SYN3 Ok</li> </ul> | -       | Normal                 | Force the status of the function. Visible only when <i>Enable stage forcing</i> parameter is enabled in <i>General</i> menu.  |
| System<br>voltages<br>are<br>measured<br>on | <ul style="list-style-type: none"> <li>Bus, Line is reference</li> <li>Line, Bus is reference</li> </ul>  | -       | Bus, Line is reference | Defines which voltage is the reference when determining dead/live status of voltages.   |
| SYN OK<br>signal<br>behaviour               | <ul style="list-style-type: none"> <li>Continuous</li> <li>Delayed continuous</li> <li>Delayed pulse</li> </ul>   | -       | Continuous             | Defines the "SYN OK" signal behaviour. When set to "Delayed continuous" there is a user defined delay before the "SYN OK" signal is activated after synchronization is achieved. When set to "Delayed pulse" the "SYN OK" signal is deactivated after user defined delay.                                 |
| SYN OK<br>delay                             | 0.000...1800.000 s  | 0.005 s | 0.050 s                |   |
| SYN OK<br>pulse<br>length                   | 0.000...1800.000 s  | 0.005 s | 0.050 s                |   |
| Use SYNx                                    | <ul style="list-style-type: none"> <li>No</li> <li>Yes</li> </ul>   | -       | No                     | Activated/de-activates the individual stages (SYN1, 2, and 3) of the synchrocheck function. Activating a stage reveals the parameter settings for the configuration.  |
| SYNx Start<br>check                         | <ul style="list-style-type: none"> <li>Always</li> <li>On start</li> </ul>  | -       | Always                 | Selects synchrocheck start behaviour. If "On start" is selected "SYNx START" input must be active for synchrochecking to begin. "SYNx START" input signal can be defined at <i>IO</i> → <i>Input control</i> menu. If "Always" is selected "SYNx START" input is not needed for synchrochecking to start. |

| Name                       | Range   | Step     | Default    | Description  |
|----------------------------|---|----------|------------|--|
| SYN1 V Reference           | <ul style="list-style-type: none"> <li>• Not in use</li> <li>• UL12</li> <li>• UL23</li> <li>• UL31</li> <li>• UL1</li> <li>• UL2</li> <li>• UL3</li> </ul> | -        | Not in use | <p>Selects the reference voltage of the stage. Please note that the available references depend on the selected mode.</p> <p>All references available:</p> <ul style="list-style-type: none"> <li>- 3LN+U4(SS)</li> <li>- 2LL+U3(U0)+U4(SS)</li> <li>- 2LL+U3(SS)+U4(U0)</li> </ul> <p>Reference options 0...3 available:</p> <ul style="list-style-type: none"> <li>- 3LL+U4(SS)</li> <li>- 2LL+U3(Not in use)+U4(SS)</li> <li>- 2LL+U3(SS)+U4(Not in use)</li> </ul> |
| SYN2 V Reference           | <ul style="list-style-type: none"> <li>• Not in use</li> <li>• UL12</li> <li>• UL23</li> <li>• UL31</li> </ul>  | -        | Not in use | <p>Selects the reference voltage of the stage. SYN2 is available when both U3 and U4 have been set to SS mode.</p>   |
| SYN3 V Reference           | <ul style="list-style-type: none"> <li>• Not in use</li> <li>• U3–U4</li> </ul>   | -        | Not in use | <p>Enables and disables the SYN3 stage. Operable in the 2LL+U3+U4 mode, with references UL12, UL23 and UL31 can be connected to the channels.</p>  |
| SYNx Switching             | <ul style="list-style-type: none"> <li>• Not in use</li> <li>• Use SynSW</li> </ul>   | -        | Not in use | <p>Disables or enables synchroswitching. Synchroswitching is available only for SYN1. When synchroswitching is used, the function automatically closes the breaker when both sides of the breaker are synchronized. This setting is only visible when "Use SYN1" is activated.</p>   |
| SYNx Switch bk time        | 0.000...1800.000s   | 0.005s   | 0.05s      | <p>Estimated time between a close command given to a breaker and the breaker entering the closed state. This setting is used to time the closing of the breaker so that both sides are as synchronized as possible when the breaker is actually closed.</p> <p>This setting is only visible when "SYN1 switching" is activated.</p>  |
| SYNx Switching object      | <ul style="list-style-type: none"> <li>• Object 1</li> <li>• Object 2</li> <li>• Object 3</li> <li>• Object 4</li> <li>• Object 5</li> </ul>                | -        | Object 1   | <p>When synchroswitching is enabled, this parameter defines which object receives the breaker's closing command. This setting is only visible when "SYNx Switching" is activated.</p>  |
| Estimated BRK closing time | 0.000...360.000s  | 0.005s   | -          | <p>Displays the estimated time until networks are synchronized.</p>  |
| Networks rotating time     | 0.000...360.000s  | 0.005s   | -          | <p>Displays the time it takes for both sides of the network to fully rotate.</p>   |
| Networks placement atm     | -360.000...360.000deg   | 0.001deg | -          | <p>Indicates the angle difference between the two sides of the breaker at the moment.</p>  |

Setting group selection controls the operating characteristics of the function, i.e. the user or user-defined logic can change function parameters while the function is running.

Table. 4.5.10 - 285. Synchrocheck stage settings.

| Name              | Range  | Step    | Default | Description  |
|-------------------|--|---------|---------|--|
| SYNx U conditions | <ul style="list-style-type: none"> <li>• LL only</li> <li>• LD only</li> <li>• DL only</li> <li>• LL &amp; LD</li> <li>• LL &amp; DL</li> <li>• LL &amp; DD</li> <li>• LL &amp; LD &amp; DL</li> <li>• LL &amp; LD &amp; DD</li> <li>• LL &amp; DL &amp; DD</li> <li>• Bypass</li> </ul> | -       | LL only | Determines the allowed states of the supervised systems.<br>L = Live<br>D = Dead |
| SYNx U live >     | 0.10...100.00%Un   | 0.01%Un | 20%Un   | The voltage limit of the live state.   |
| SYNx U dead <     | 0.00...100.00%Un   | 0.01%Un | 20%Un   | The voltage limit of the dead state. Not in use when set to 0%Un                 |
| SYNx U diff <     | 2.00...50.00%Un  | 0.01%Un | 2.00%Un | The maximum allowed voltage difference between the systems.                      |
| SYNx angle diff < | 3.00...90.00deg  | 0.01deg | 3deg    | The maximum allowed angle difference between the systems.                        |
| SYNx freq diff <  | 0.05...0.50Hz  | 0.01Hz  | 0.1Hz   | The maximum allowed frequency difference between the systems.                    |

## Events and registers

The synchrocheck function (abbreviated "SYN" in event block names) generates events and registers from the status changes in the events listed below. The user can select which event messages are stored in the main event buffer: ON, OFF, or both. The events triggered by the function are recorded with a time stamp.

The function's outputs can be used for direct I/O controlling and user logic programming.

The function offers three (3) independent stages; the events are segregated for each stage operation.

Table. 4.5.10 - 286. Event messages.

| Event block name | Event names                   |
|------------------|-------------------------------|
| SYN1             | SYN1 Blocked ON/OFF           |
| SYN1             | SYN1 Ok ON/OFF                |
| SYN1             | SYN1 Bypass ON/OFF            |
| SYN1             | SYN1 Volt condition OK        |
| SYN1             | SYN1 Volt cond not match      |
| SYN1             | SYN1 Volt diff Ok             |
| SYN1             | SYN1 Volt diff out of setting |
| SYN1             | SYN1 Angle diff Ok            |

| Event block name | Event names  |
|------------------|--|
| SYN1             | SYN1 Angle diff out of setting                           |
| SYN1             | SYN1 Frequency diff Ok                                   |
| SYN1             | SYN1 Frequency diff out of setting                       |
| SYNX1            | SYN1 Voltage difference Ok ON/OFF                        |
| SYNX1            | SYN1 Angle difference Ok ON/OFF                          |
| SYNX1            | SYN1 Frequency difference Ok ON/OFF                      |
| SYNX1            | SYN1 Live Live Condition ON/OFF                          |
| SYNX1            | SYN1 Live Dead Condition ON/OFF                          |
| SYNX1            | SYN1 Dead Live Condition ON/OFF                          |
| SYNX1            | SYN1 Dead Dead Condition ON/OFF                          |
| SYNX1            | SYN1 Voltage Difference too high Vbus > Vline ON/OFF     |
| SYNX1            | SYN1 Voltage Difference too high Vline > Vbus ON/OFF     |
| SYNX1            | SYN1 Frequency Difference too high fbus > fline ON/OFF   |
| SYNX1            | SYN1 Frequency Difference too high fline > fbus ON/OFF   |
| SYNX1            | SYN1 Angle Difference too high a bus leads a line ON/OFF |
| SYNX1            | SYN1 Angle Difference too high a line leads a bus ON/OFF |
| SYNX1            | SYN1 Bus voltage Live ON/OFF                             |
| SYNX1            | SYN1 Bus voltage Dead ON/OFF                             |
| SYNX1            | SYN1 Line voltage Live ON/OFF                            |
| SYNX1            | SYN1 Line voltage Dead ON/OFF                            |

The function registers its operation into the last twelve (12) time-stamped registers. The table below presents the structure of the function's register content.

Table. 4.5.10 - 287. Register content.

| Name              | Range  |
|-------------------|--|
| Date and time     | dd.mm.yyyy hh:mm:ss.mss                      |
| Event             | Event name                                   |
| SYNx Ref1 voltage | The reference voltage of the selected stage. |
| SYNx Ref2 voltage | The reference voltage of the selected stage. |
| SYNx Volt Cond    | The voltage condition of the selected stage. |
| SYNx Volt status  | The voltage status of the selected stage.    |

| Name                 | Range  |
|----------------------|--|
| SYNx Vdiff           | The voltage difference of the selected stage.                        |
| SYNx Vdiff cond      | The set condition of the voltage difference of the selected stage.   |
| SYNx Adiff           | The angle difference of the selected stage.                          |
| SYNx Adiff cond      | The set condition of the angle difference of the selected stage.     |
| SYNx fdiff           | The frequency difference of the selected stage.                      |
| SYNx fdiff cond      | The set condition of the frequency difference of the selected stage. |
| Setting group in use | Setting group 1...8 active.  |

### 4.5.11 Milliampere output control

The milliamp current loop is the prevailing process control signal in many industries. It is an ideal method of transferring process information because a current does not change as it travels from a transmitter to a receiver. It is also much more simple and cost-effective.

The benefits of 4...20 mA loops:

- the dominant standard in many industries
- the simplest option to connect and configure
- uses less wiring and connections than other signals, thus greatly reducing initial setup costs
- good for travelling long distances, as current does not degrade over long connections like voltage does
- less sensitive to background electrical noise
- detects a fault in the system incredibly easily since 4 mA is equal to 0 % output.

#### Milliampere (mA) outputs

The device supports up to two (2) independent mA option cards. Each card has four (4) mA output channels and one (1) mA input channel. If the device has an mA option card, enable mA outputs at *Control* → *Device IO* → *mA outputs*. The outputs are activated in groups of two: channels 1 and 2 are activated together, as are channels 3 and 4.

Table. 4.5.11 - 288. Main settings (output channels).

| Name             |                                   | Range   | Default  | Description   |
|------------------|-----------------------------------|---|----------|---|
| mA option card 1 | Enable mA output channels 1 and 2 | <ul style="list-style-type: none"> <li>• Disabled</li> <li>• Enabled</li> </ul> | Disabled | Enables and disables the outputs of the mA output card 1. |
|                  | Enable mA output channels 3 and 4 |   |          |   |
| mA option card 2 | Enable mA output channels 5 and 6 | <ul style="list-style-type: none"> <li>• Disabled</li> <li>• Enabled</li> </ul> | Disabled | Enables and disables the outputs of the mA output card 2. |
|                  | Enable mA output channels 7 and 8 |   |          |   |

Table. 4.5.11 - 289. Settings for mA output channels.

| Name                                      | Range   | Step     | Default   | Description  |
|---|---|----------|---|--|
| Enable mA output channel                  | <ul style="list-style-type: none"> <li>Disabled</li> <li>Enabled</li> </ul>   | -        | Disabled  | Enables and disables the selected mA output channel. If the channel is disabled, the channel settings are hidden.  |
| Magnitude selection for mA output channel | <ul style="list-style-type: none"> <li>Currents</li> <li>Voltages</li> <li>Powers</li> <li>Impedance and admittance</li> <li>Other</li> </ul> | -        | Currents  | Defines the measurement category that is used for mA output control.   |
| Magnitude of mA output channel            | (dependent on the measurement category selection)   | -        | (dependent on the measurement category selection) | Defines the measurement magnitude used for mA output control. The available measurements depend on the selection of the "Magnitude selection for mA output channel" parameter. |
| Input value 1                             | $-10^7 \dots 10^7$  | 0.001    | 0   | The first input point in the mA output control curve.  |
| Scaled mA output value 1                  | 0.0000...24.0000mA  | 0.0001mA | 0mA   | The mA output value when the measured value is equal to or less than Input value 1.  |
| Input value 2                             | $-10^7 \dots 10^7$  | 0.001    | 1   | The second input point in the mA output control curve.   |
| Scaled mA output value 2                  | 0.0000...24.0000mA  | 0.0001mA | 0mA   | The mA output value when the measured value is equal to or greater than Input value 2.   |

Figure. 4.5.11 - 164. Example of the effects of mA output channel settings.

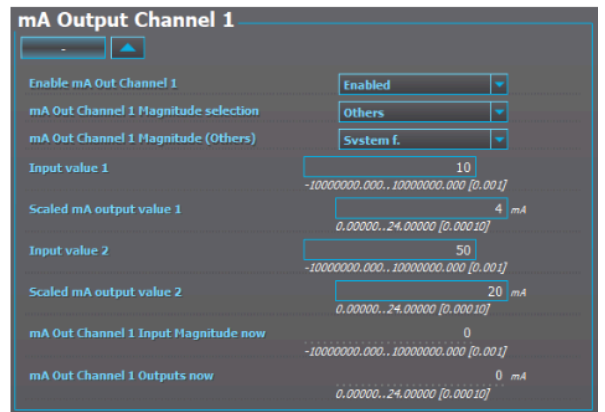
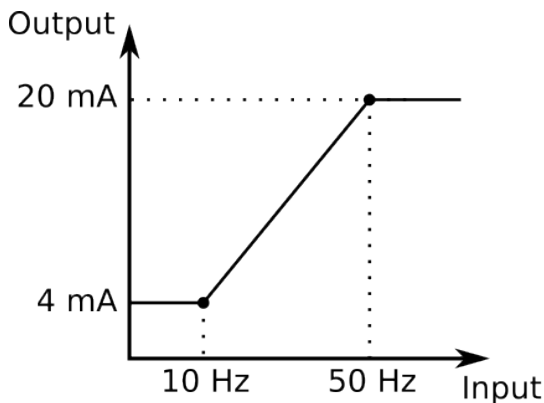

Table. 4.5.11 - 290. Hardware indications.

| Name                                 | Range  | Description   |
|--------------------------------------|--|---|
| Hardware in mA output channels 1...4 | <ul style="list-style-type: none"> <li>• None</li> <li>• Slot A</li> <li>• Slot B</li> <li>• Slot C</li> <li>• Slot D</li> <li>• Slot E</li> <li>• Slot F</li> <li>• Slot G</li> <li>• Slot H</li> <li>• Slot I</li> <li>• Slot J</li> <li>• Slot K</li> <li>• Slot L</li> <li>• Slot M</li> <li>• Slot N</li> <li>• Too many cards installed</li> </ul> | Indicates the option card slot where the mA output card is located. |
| Hardware in mA output channels 5...8 |  |   |

Table. 4.5.11 - 291. Measurement values reported by mA output cards.

| Name                               | Range              | Step     | Description   |
|------------------------------------|--------------------|----------|---|
| mA in Channel 1                    | 0.0000...24.0000mA | 0.0001mA | Displays the measured mA value of the selected input channel.               |
| mA in Channel 2                    |                    |          |   |
| mA Out Channel Input Magnitude now | $-10^7 \dots 10^7$ | 0.001    | Displays the input value of the selected mA output channel at that moment.  |
| mA Out Channel Outputs now         | 0.0000...24.0000mA | 0.0001mA | Displays the output value of the selected mA output channel at that moment. |

### 4.5.12 Programmable control switch

The programmable control switch is a control function that controls its binary output signal. This output signal can be controlled locally from the device's mimic or remotely from the RTU. The main purpose of programmable control switches is to block or enable function and to change function properties by changing the setting group. However, this binary signal can also be used for any number of other purposes, just like all other binary signals. Once a programmable control switch has been activated or disabled, it remains in that state until given a new command to switch to the opposite state (see the image below). The switch cannot be controlled by an auxiliary input, such as digital inputs or logic signals; it can only be controlled locally (mimic) or remotely (RTU).

Figure. 4.5.12 - 165. When a PCS has been controlled "ON" or "OFF", the PCS will keep its state.

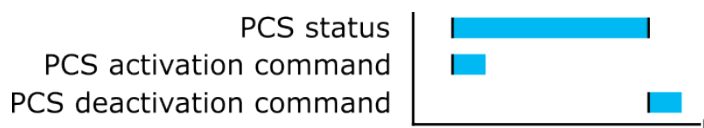

## Setting up a switch in the mimic editor

Figure. 4.5.12 - 166. Programmable control switch setup in the mimic editor.

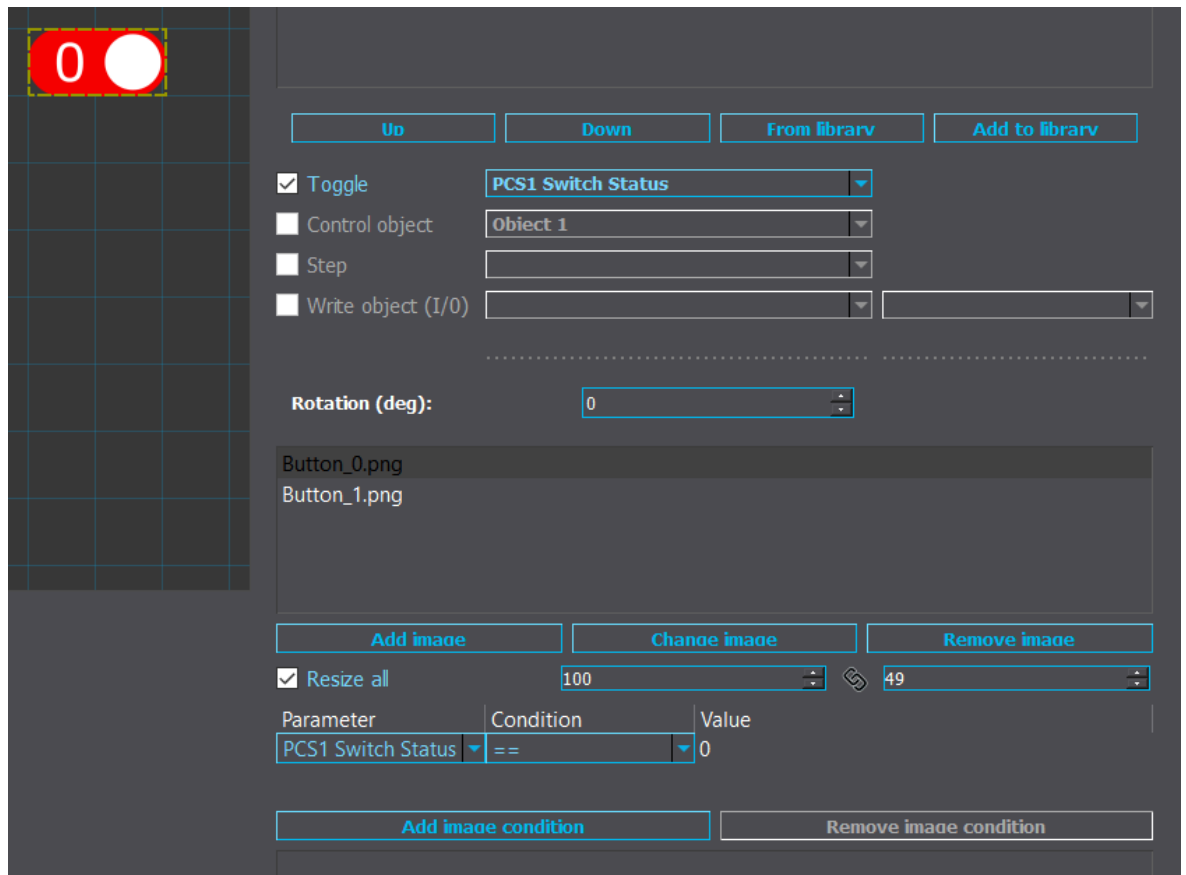

When an item has been added to the mimic, a collection of toggleable buttons can be found from the library with the "From library" button. To make an item a "programmable control switch", select one of the programmable switches (PCS1...5 Switch status) from the "Toggle" dropdown menu. After this select one of the images in the item ("Button\_0.png" and "Button\_1.png" in the example image above) and then choose the corresponding programmable control switch as the image condition. In the example image "Button\_0.png" is displayed when "PCS1 Switch Status == 0". Set the other image (in this case "Button\_1.png") to "PCS1 Switch Status == 1". When this is done, the image displayed by the item will follow the status of the programmable control switch.

If more than five toggleable switches are needed, logical inputs can also be set for the same purpose. The only difference is that the status of logical inputs are set to zero when the processor is rebooted, whereas programmable control switches keep the status.

### Settings.

These settings can be accessed at *Control* → *Device I/O* → *Programmable control switch*.

Table. 4.5.12 - 292. Settings.

| Name        | Range | Default | Description  |
|-------------|-------|---------|--|
| Switch name | -     | Switchx | The user-settable name of the selected switch. The name can be up to 32 characters long. |

| Name                           | Range  | Default      | Description  |
|--------------------------------|--|--------------|--|
| Access level for Mimic control | <ul style="list-style-type: none"> <li>User</li> <li>Operator</li> <li>Configurator</li> <li>Super user</li> </ul> | Configurator | Determines which access level is required to be able to control the programmable control switch via the Mimic. |

## Events

The programmable control switch function (abbreviated "PCS" in event block names) generates events from the status changes in the events listed below. The user can select which event messages are stored in the main event buffer: ON, OFF, or both. The events triggered by the function are recorded with a time stamp. The function offers five (5) independent switches. The function's output signals can be used for direct I/O controlling and user logic programming.

Table. 4.5.12 - 293. Event messages.

| Event block name | Event names     |
|------------------|-----------------|
| PCS              | Switch 1 ON/OFF |
| PCS              | Switch 2 ON/OFF |
| PCS              | Switch 3 ON/OFF |
| PCS              | Switch 4 ON/OFF |
| PCS              | Switch 5 ON/OFF |

### 4.5.13 Function buttons

AQ 250 devices have twelve (12) physical function buttons in the front panel of the device. The main purpose of function buttons is to block or enable functions and to change function properties by changing the setting group. However, this binary signal can also be used for any number of other purposes, just like all other binary signals.

Function buttons have two operation modes: "Press release" and "Toggle On/Off". In "Press release" mode the button status is active while the button is pressed down. In "Toggle On/Off" mode the button status toggles between "On" and "Off". Each button has a user configurable LED at the top left corner of the button. The LED can be configured to activate red, orange or green color from button status or any other logical binary signal.

General button settings and LED activation settings can be set at *Control* → *Device IO* → *Function Button Settings*.



#### NOTICE!

The status of the function button outputs can only be controlled from the front panel i.e. can't be controlled remotely. Therefore it is recommended to use "a virtual button" (programmable control switches or logical inputs) if a toggleable signal must be controlled both locally and remotely.

Table. 4.5.13 - 294. User button settings

| Name   | Range  | Step | Default       | Description  |
|--|--|------|---------------|--|
| Access level for function buttons              | <ul style="list-style-type: none"> <li>User</li> <li>Operator</li> <li>Configurator</li> <li>Super user</li> </ul> | -    | Operator      | Determines which access level is required to be able to control the buttons.   |
| Consider Local/ Remote switch for push-buttons | <ul style="list-style-type: none"> <li>No</li> <li>Yes</li> </ul>  | -    | No            | When set to "Yes", the buttons can be operated only when the "L/R" button has been set to "Local" mode .   |
| User editable description button 1...12        | -  | -    | BTN1...12     | Description of the button. If "Function button" view has been added to the "Carousel design", these descriptions are used for the buttons.   |
| Function button 1...12 mode                    | Press release<br>Toggle On/Off   | -    | Press release | Defines the operation mode of the button. In "Press release" mode the button signal is active while the button is pressed down. In "Toggle On/Off" mode the button signal changes status between "On" and "Off" each time the button is pressed. |

Table. 4.5.13 - 295. Function button output signals

| Signal name                          | Description                          |
|--------------------------------------|--------------------------------------|
| Status Function Button 1...12 ON/OFF | "On" and "Off" status of each button |

## 4.5.14 Analog input scaling curves

Sometimes when measuring with RTD inputs, milliampere inputs and digital inputs the measurement might be inaccurate because the signal coming from the source is inaccurate. One common example of this is tap changer location indication signal not changing linearly from step to step. If the output difference between the steps are not equal to each other, measuring the incoming signal accurately is not enough. "Analog input scaling curves" menu can be used to take these inaccuracies into account.

Analog input scaling curve settings can be found at *Measurement* → *AI(mA, DI volt) scaling* menu.

Currently following measurements can be scaled with analog input scaling curves:

- RTD inputs and mA inputs in "RTD & mA input" option cards
- mA inputs in "4x mA output & 1x mA input" option cards
- mA input in "4x mA input & 1x mA output" option cards
- Digital input voltages

Table. 4.5.14 - 296. Main settings (input channel).

| Name                 | Range   | Step | Default  | Description                     |
|----------------------|---|------|----------|---------------------------------|
| Analog input scaling | <ul style="list-style-type: none"> <li>Disabled</li> <li>Activated</li> </ul> | -    | Disabled | Enables and disables the input. |

| Name   | Range   | Step    | Default     | Description  |
|--|---|---------|-------------|--|
| Scaling curve 1...10                           | <ul style="list-style-type: none"> <li>• Disabled</li> <li>• Activated</li> </ul>   | -       | Disabled    | Enables and disables the scaling curve and the input measurement.  |
| Curve 1...10 input signal select               | <ul style="list-style-type: none"> <li>• S7 mA Input</li> <li>• S8 mA Input</li> <li>• S15 mA Input</li> <li>• S16 mA Input</li> <li>• DI1...DI20 Voltage</li> <li>• RTD S1...S16 Resistance</li> <li>• mA In 1 (I card 1)</li> <li>• mA In 2 (I card 2)</li> <li>• mA In 1 (T card 1)</li> <li>• mA In 2 (T card 1)</li> <li>• mA In 3 (T card 1)</li> <li>• mA In 4 (T card 1)</li> <li>• mA In 1 (T card 2)</li> <li>• mA In 2 (T card 2)</li> <li>• mA In 3 (T card 2)</li> <li>• mA In 4 (T card 2)</li> </ul> | -       | S7 mA Input | Defines the measurement used by scaling curve.   |
| Curve 1...10 input signal filtering            | <ul style="list-style-type: none"> <li>• No</li> <li>• Yes</li> </ul>   | -       | No          | Enables calculation of the average of received signal.   |
| Curve 1...10 input signal filter time constant | 0.005...3800.000 s  | 0.005 s | 1 s         | Time constant for input signal filtering. This parameter is visible when "Curve 1...4 input signal filtering" has been set to "Yes".   |
| Curve 1...10 input signal out of range set     | <ul style="list-style-type: none"> <li>• No</li> <li>• Yes</li> </ul>   | -       | No          | Enables out of range signals. If input signal is out of minimum and maximum limits, "ASC1...4 input out of range" signal is activated. |
| Curve1...10 input minimum                      | -1 000 000.00...1 000 000.00  | 0.00001 | 0           | Defines the minimum input of the curve. If input is below the set limit, "ASC1...4 input out of range" is activated.                   |
| Curve 1...10 input                             | -1 000 000.00...1 000 000.00  | 0.00001 | -           | Displays the input measurement received by the curve.  |
| Curve1...10 input maximum                      | -1 000 000.00...1 000 000.00  | 0.00001 | 0           | Defines the maximum input of the curve. If input is above the set limit, "ASC1...4 input out of range" is activated.                   |

| Name               | Range                              | Step    | Default | Description                       |
|--------------------|------------------------------------|---------|---------|-----------------------------------|
| Curve1...10 output | -1 000<br>000.00...1 000<br>000.00 | 0.00001 | -       | Displays the output of the curve. |

The input signal filtering parameter calculates the average of received signals according to the set time constant. This is why rapid changes and disturbances (such as fast spikes) are smothered. The Nyquist rate states that the filter time constant must be at least double the period time of the disturbance process signal. For example, the value for the filter time constant is 2 seconds for a 1 second period time of a disturbance oscillation.

$$H(s) = \frac{Wc}{s+Wc} = \frac{1}{1+s/Wc}$$

When the curve signal is out of range, it activates the "ASC1...10 input out of range" signal, which can be used inside logic or with other functions of the device. The signal can be assigned directly to an output relay or to an LED in the I/O matrix. The "Out of range" signal is activated, when the measured signal falls below the set input minimum limit, or when it exceeds the input maximum limit.

If for some reason the input signal is lost, the value is fixed to the last actual measured cycle value. The value does not go down to the minimum if it has been something else at the time of the signal breaking.

Table. 4.5.14 - 297. Output settings and indications.

| Name                      | Range   | Step        | Default        | Description  |
|---------------------------|---|-------------|----------------|--|
| Curve 1...10 update cycle | 5...10 000ms  | 5ms         | 150ms          | Defines the length of the input measurement update cycle. If the user wants a fast operation, this setting should be fairly low. |
| Scaled value handling     | <ul style="list-style-type: none"> <li>• Floating point</li> <li>• Integer out (Floor)</li> <li>• Integer (Ceiling)</li> <li>• Integer (Nearest)</li> </ul> | -           | Floating point | Rounds the milliampere signal output as selected.  |
| Input value 1             | 0...4000  | 0.000<br>01 | 0              | The measured input value at Curve Point 1.   |
| Scaled output value 1     | $-10^7...10^7$  | 0.000<br>01 | 0              | Scales the measured milliampere signal at Point 1.   |
| Input value 2             | 0...4000  | 0.000<br>01 | 1              | The measured input value at Curve Point 2.   |
| Scaled output value 1     | $-10^7...10^7$  | 0.000<br>01 | 0              | Scales the measured milliampere signal at Point 2.   |

| Name                  | Range  | Step | Default  | Description  |
|-----------------------|--|------|----------|--|
| Add curvepoint 3...20 | <ul style="list-style-type: none"> <li>Not used</li> <li>Used</li> </ul> | -    | Not used | Allows the user to create their own curve with up to twenty (20) curve points, instead of using a linear curve between two points. |

### 4.5.15 Logical outputs

Logical outputs are used for sending binary signals out from a logic that has been built in the logic editor. Logical signals can be used for blocking functions, changing setting groups, controlling digital outputs, activating LEDs, etc. The status of logical outputs can also be reported to a SCADA system. 64 logical outputs are available. The figure below presents a logic output example where a signal from the circuit breaker failure protection function controls the digital output relay number 3 ("OUT3") when the circuit breaker's cart status is "In".

Figure. 4.5.15 - 167. Logic output example. Logical output is connected to an output relay in matrix.

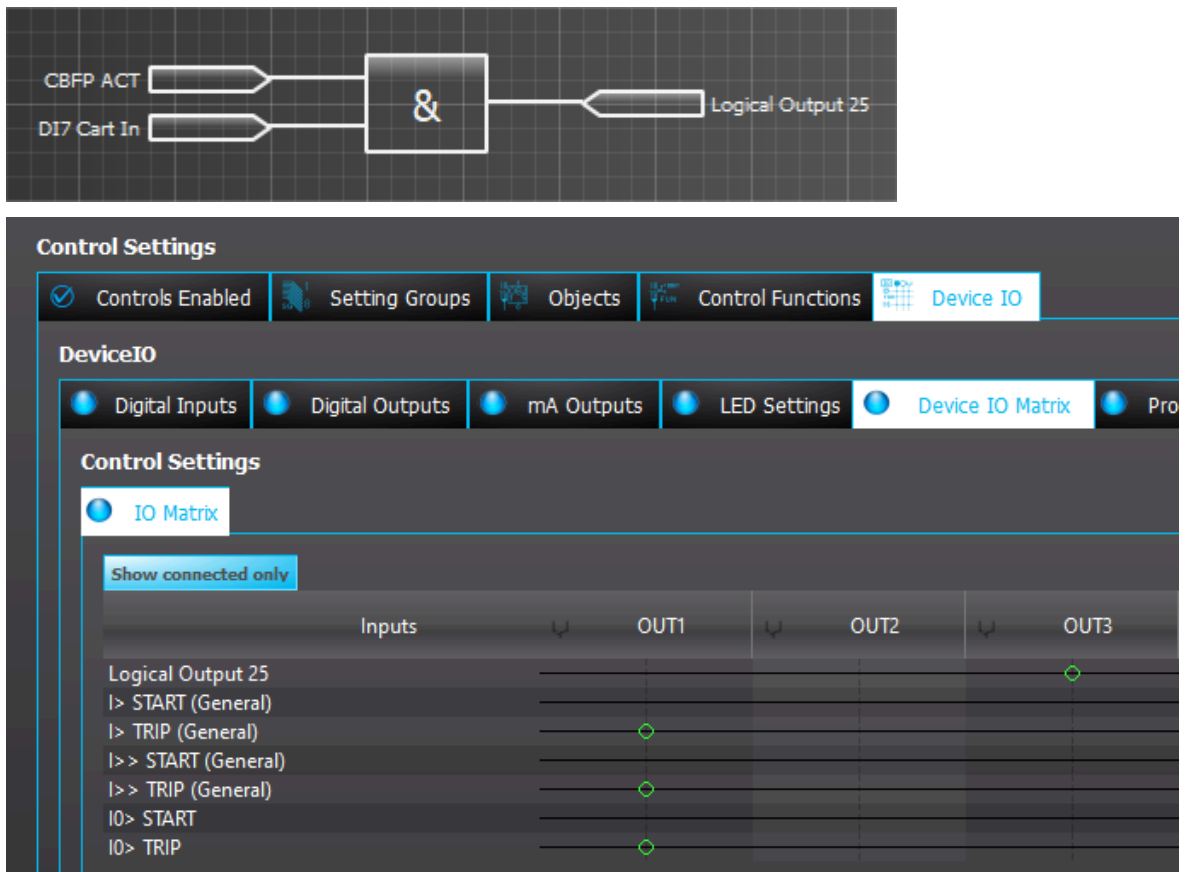

### Logical output descriptions

Logical outputs can be given a description. The user defined description are displayed in most of the menus:

- logic editor
- matrix
- block settings
- event history
- disturbance recordings
- etc.

Table. 4.5.15 - 298. Logical output user description.

| Name                                  | Range             | Default                  | Description  |
|---------------------------------------|-------------------|--------------------------|--|
| User editable description<br>LO1...64 | 1...31 characters | Logical output<br>1...64 | Description of the logical output. This description is used in several menu types for easier identification. |



**NOTICE!**

After editing user descriptions the event history will start to use the new description only after resetting the HMI. HMI can be reset from *General* → *Device info* → *HMI restart*.

### Events

The logical outputs (abbreviated "LOGIC" in event block names) generates events from the status changes in the events listed below. The user can select which event messages are stored in the main event buffer: ON, OFF, or both. The events triggered by the function are recorded with a time stamp. The function's output signals can be used for direct I/O controlling and user logic programming.

Table. 4.5.15 - 299. Event messages.

| Event block name | Event names                |
|------------------|----------------------------|
| LOGIC1           | Logical out 1...32 ON/OFF  |
| LOGIC3           | Logical out 33...64 ON/OFF |

### 4.5.16 Logical inputs

Logical inputs are binary signals that a user can control manually to change the behavior of the device or to give direct control commands. Logical inputs can be controlled with a virtual switch built in the mimic and from a SCADA system. Logical inputs are volatile signals: their status will always return to "0" when the device is rebooted. 32 logical inputs are available.

Logical inputs have two modes available: Hold and Pulse. When a logical input which has been set to "Hold" mode is controlled to "1", the input will switch to status "1" and it stays in that status until it is given a control command to go to status "0" or until the device is rebooted. When a logical input which has been set to "Pulse" mode is controlled to "1", the input will switch to status "1" and return back to "0" after 5 ms.

The figure below presents the operation of a logical input in Hold mode and in Pulse mode.

Figure. 4.5.16 - 168. Operation of logical input in "Hold" and "Pulse" modes.

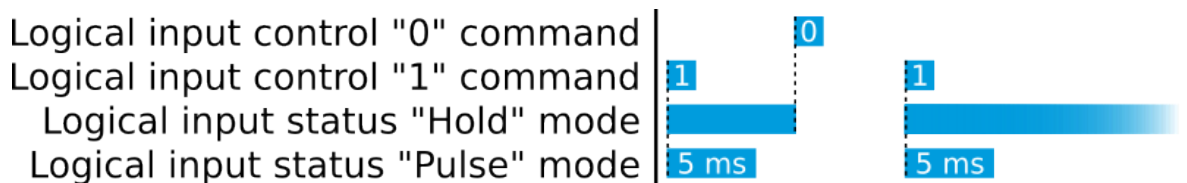

A logical input pulse can also be extended by connecting a DELAY-low gate to a logical output, as has been done in the example figure below.

Figure. 4.5.16 - 169. Extending a logical input pulse.

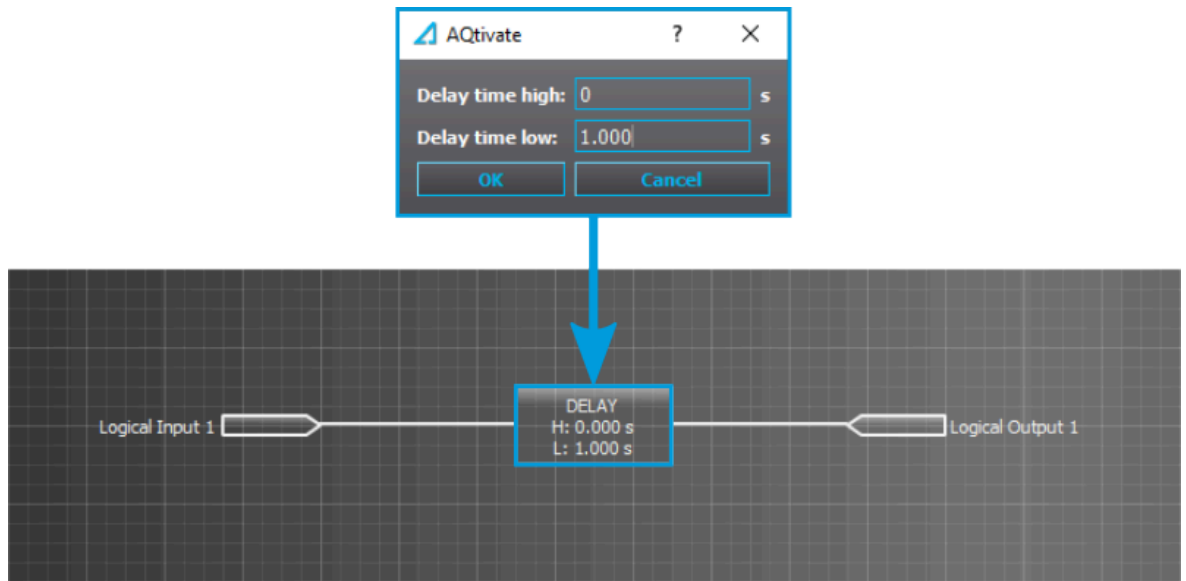

Logical input control "1" command  
 Logical input status "Pulse" mode  
 Logical output status

1  
 5 ms  
 Delay low setting

### Logical input descriptions

Logical inputs can be given a description. The user defined description are displayed in most of the menus:

- logic editor
- matrix
- block settings
- event history
- disturbance recordings
- etc.

Table. 4.5.16 - 300. Logical input user description.

| Name                               | Range             | Default              | Description   |
|------------------------------------|-------------------|----------------------|---|
| User editable description LI1...32 | 1...31 characters | Logical input 1...32 | Description of the logical input. This description is used in several menu types for easier identification. |



**NOTICE!**

After editing user descriptions the event history will start to use the new description only after resetting the HMI. HMI can be reset from *General* → *Device info* → *HMI restart*.

## Events

The logical outputs (abbreviated "LOGIC" in event block names) generates events from the status changes in the events listed below. The user can select which event messages are stored in the main event buffer: ON, OFF, or both. The events triggered by the function are recorded with a time stamp. The function's output signals can be used for direct I/O controlling and user logic programming.

Table. 4.5.16 - 301. Event messages.

| Event block name | Event names              |
|------------------|--------------------------|
| LOGIC2           | Logical in 1...32 ON/OFF |

## 4.6 Monitoring functions

### 4.6.1 Current transformer supervision

The current transformer supervision function (abbreviated CTS in this document) is used for monitoring the CTs as well as the wirings between the device and the CT inputs for malfunctions and wire breaks. An open CT circuit can generate dangerously high voltages into the CT secondary side, and cause unintended activations of current balance monitoring functions.

Figure. 4.6.1 - 170. Secondary circuit fault in phase L1 wiring.

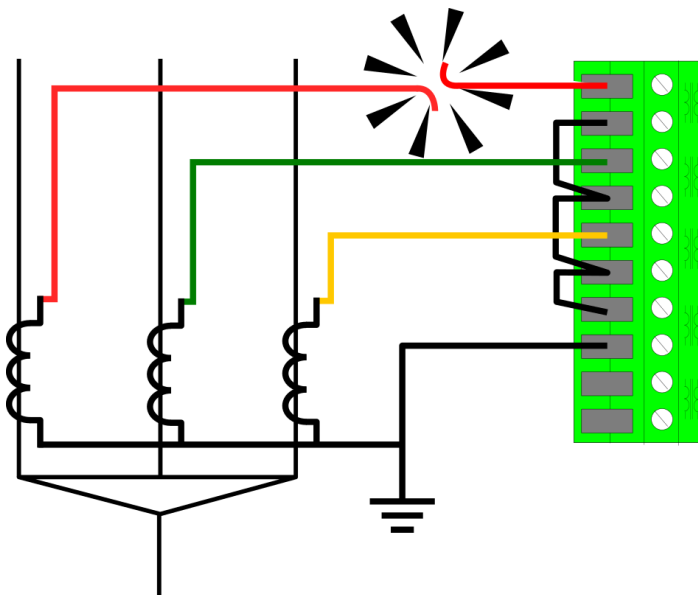

The function constantly monitors the instant values and the key calculated magnitudes of the phase currents. Additionally, the residual current circuit can be monitored if the residual current is measured from a dedicated residual current CT. The user can enable and disable the residual circuit monitoring at will.

The following conditions have to be met simultaneously for the function alarm to activate:

- None of the three-phase currents exceeds the  $I_{set}$  high limit setting.
- At least one of the three-phase currents exceeds the  $I_{set}$  low limit setting.
- At least one of the three-phase currents are below the  $I_{set}$  low limit setting.
- The ratio between the calculated minimum and maximum of the three-phase currents is below the  $I_{set}$  ratio setting.

- The ratio between the negative sequence and the positive sequence exceeds the  $I2/I1$  ratio setting.
- The calculated difference  $(IL1+IL2+IL3+I0)$  exceeds the  $I_{sum}$  difference setting (optional).
- The above-mentioned condition is met until the set time delay for alarm.

Figure. 4.6.1 - 171. Simplified function block diagram of the CTS function.

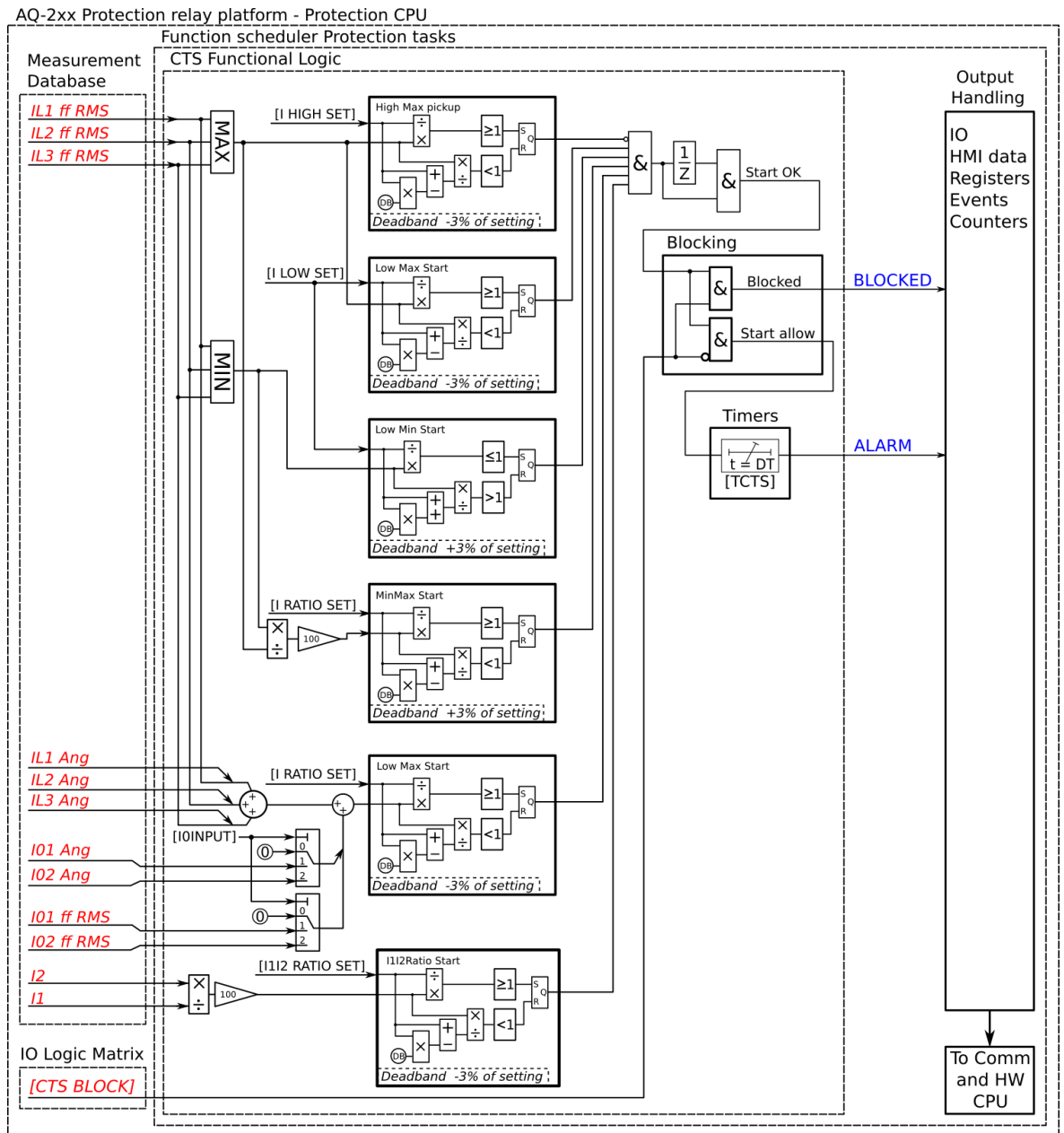

### Measured input

The function block uses fundamental frequency component of phase current measurement values and residual current measurement values. The function supervises the angle of each current measurement channel. Positive sequence current and negative sequence currents are calculated from the phase currents. The user can select what is used for the residual current measurement: nothing, the I01 channel, or the I02 channel.

Table. 4.6.1 - 302. Measured inputs of the CTS function.

| Signal      | Description   |
|-------------|---|
| $I_{L1RMS}$ | Fundamental frequency component of phase L1 (A) current |
| $I_{L2RMS}$ | Fundamental frequency component of phase L2 (B) current |
| $I_{L3RMS}$ | Fundamental frequency component of phase L3 (C) current |
| $I_{01RMS}$ | Fundamental frequency component of residual input I01   |
| $I_{02RMS}$ | Fundamental frequency component of residual input I02   |

## General settings

The following general settings define the general behavior of the function. These settings are static i.e. it is not possible to change them by editing the setting group.

Table. 4.6.1 - 303. General settings of the function.

| Name                         | Range  | Default    | Description   |
|------------------------------|--|------------|---|
| CTS LN mode                  | <ul style="list-style-type: none"> <li>On</li> <li>Blocked</li> <li>Test</li> <li>Test/Blocked</li> <li>Off</li> </ul> | On         | Set mode of CTS block.<br>This parameter is visible only when <i>Allow setting of individual LN mode</i> is enabled in <i>General</i> menu.   |
| CTS force status to          | <ul style="list-style-type: none"> <li>Normal</li> <li>Alarm</li> <li>Blocked</li> </ul>                               | Normal     | Force the status of the function. Visible only when <i>Enable stage forcing</i> parameter is enabled in <i>General</i> menu.  |
| I0 input selection           | <ul style="list-style-type: none"> <li>Not in use</li> <li>I01</li> <li>I02</li> </ul>                                 | Not in use | Selects the measurement input for the residual current. If the residual current is measured with a separate CT, the residual current circuit can be monitored with the CTS function as well. However, this does not apply to summing connections (Holmgren, etc.). If the phase current CT is summed with I01 or I02, this selection should be set to "Not in use". |
| I0 direction                 | <ul style="list-style-type: none"> <li>Add</li> <li>Subtract</li> </ul>  | Add        | Defines the polarity of residual current channel connection.  |
| Compensate natural unbalance | <ul style="list-style-type: none"> <li>-</li> <li>Comp</li> </ul>  | -          | When activated while the line is energized, the currently present calculated residual current is compensated to 0.  |

## Pick-up settings

The  $I_{set}$  and  $I_{0set}$  setting parameters control the current-dependent pick-up and activation of the current transformer supervision function. They define the minimum and maximum allowed measured current before action from the function. The function constantly calculates the ratio between the setting values and the measured magnitude ( $I_m$ ) for each of the three phases and for the selected residual current input. The reset ratio of 97 % and 103% are built into the function and is always relative to the  $I_{set}$  value. The setting value is common for all measured amplitudes, and when the  $I_m$  exceeds the  $I_{set}$  value (in single, dual or all currents) it triggers the pick-up operation of the function.

Setting group selection controls the operating characteristics of the function, i.e. the user or user-defined logic can change function parameters while the function is running.

Table. 4.6.1 - 304. Pick-up settings.

| Name                 | Range               | Step        | Default     | Description   |
|----------------------|---------------------|-------------|-------------|---|
| $I_{set}$ high limit | 0.01...40.00× $I_n$ | 0.01× $I_n$ | 1.20× $I_n$ | Determines the pick-up threshold for phase current measurement. This setting limit defines the upper limit for the phase current's pick-up element. If this condition is met, it is considered as fault and the function is not activated.  |
| $I_{set}$ low limit  | 0.01...40.00× $I_n$ | 0.01× $I_n$ | 0.10× $I_n$ | Determines the pick-up threshold for phase current measurement. This setting limit defines the lower limit for the phase current's pick-up element. This condition has to be met for the function to activate.  |
| $I_{set}$ ratio      | 0.01...100.00%      | 0.01%       | 10.00%      | Determines the pick-up ratio threshold between the minimum and maximum values of the phase current. This condition has to be met for the function to activate.  |
| $I_{2/1}$ ratio      | 0.01...100.00%      | 0.01%       | 49.00%      | Determines the pick-up ratio threshold for the negative and positive sequence currents calculated from the phase currents. This condition has to be met for the function to activate. The ratio is 50 % for a full single-phasing fault (i.e. when one of the phases is lost entirely). Setting this at 49 % allows a current of 0.01 × $I_n$ to flow in one phase, while the other two are at nominal current. |
| $I_{sum}$ difference | 0.01...40.00× $I_n$ | 0.01× $I_n$ | 0.10× $I_n$ | Determines the pick-up ratio threshold for the calculated residual phase current and the measured residual current. If the measurement circuit is healthy, the sum of these two currents should be 0.   |
| Time delay for alarm | 0.000...1800.000s   | 0.005s      | 0.5s        | Determines the delay between the activation of the function and the alarm.  |

### Read-only parameters

The function's *Info* page displays useful, real-time information on the state of the protection function. It is accessed either through the device's HMI display, or through the setting tool software when it is connected to the device and its Live Edit mode is active.

Table. 4.6.1 - 305. Information displayed by the function.

| Name             | Range  | Step | Description   |
|------------------|--|------|---|
| CTS LN behaviour | <ul style="list-style-type: none"> <li>• On</li> <li>• Blocked</li> <li>• Test</li> <li>• Test/Blocked</li> <li>• Off</li> </ul> | -    | Displays the mode of CTS block. This parameter is visible only when <i>Allow setting of individual LN mode</i> is enabled in <i>General</i> menu. |

| Name                                 | Range  | Step     | Description   |
|--------------------------------------|--|----------|---|
| Uncompensated residual unbalance Pri | <ul style="list-style-type: none"> <li>• Normal</li> <li>• Start</li> <li>• Trip</li> <li>• Blocked</li> </ul> | -        | Displays the natural unbalance of current after compensating it with <i>Compensate natural unbalance</i> parameter. |
| Natural unbalance ang                | -360.00...360.00 deg   | 0.01 deg | Displays the natural unbalance of angle after compensating it with <i>Compensate natural unbalance</i> parameter.   |
| Measured current difference Isum, I0 | 0.00...50.00 xIn   | 0.01 xIn | Current difference between summed phases and residual current.  |
| Measured angle difference Isum, I0   | -360...360 deg   | 0.01 deg | Angle difference between summed phases and residual current.  |

### Function blocking

The block signal is checked in the beginning of each program cycle. The blocking signal is received from the blocking matrix in the function's dedicated input. If the blocking signal is not activated when the pick-up element activates, a START signal is generated and the function proceeds to the time characteristics calculation.

If the blocking signal is active when the pick-up element activates, a BLOCKED signal is generated and the function does not process the situation further. If the START function has been activated before the blocking signal, it resets and the release time characteristics are processed similarly to when the pick-up signal is reset.

The variables the user can set are binary signals from the system. The blocking signal needs to reach the device minimum of 5 ms before the set operating delay has passed in order for the blocking to activate in time.

### Operating time characteristics

This function supports definite time delay (DT). For detailed information on this delay type please refer to the chapter "[General properties of a protection function](#)" and its section "[Operating time characteristics](#)".

### Typical cases of current transformer supervision

The following nine examples present some typical cases of the current transformer supervision and their setting effects.

Figure. 4.6.1 - 172. All works properly, no faults.

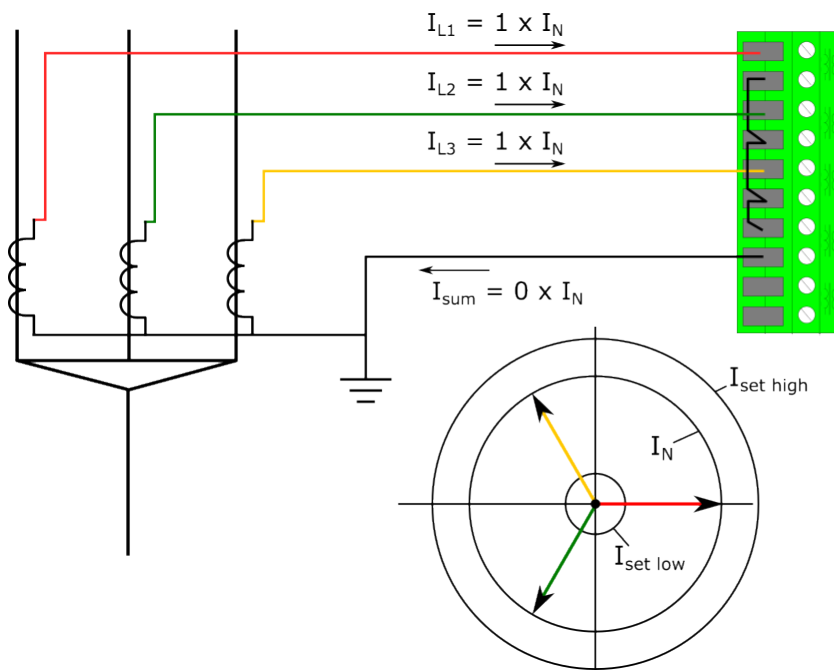

**Settings:**

$I_{set}$  High limit =  $1.20 \times I_N$   
 $I_{set}$  Low limit =  $0.10 \times I_N$   
 $I_{set}$  ratio = 10.00 %  
 $I1/I2$  ratio = 49.00 %  
 $I_0$  input = Not in use

**Measurements:**

$I_{min}$  =  $1 \times I_N$   
 $I_{max}$  =  $1 \times I_N$   
 $I1$  =  $1 \times I_N$   
 $I2$  =  $0 \times I_N$   
 $I_{min}/I_{max}$  = 1  
 $I2/I1$  = 0%

**CTS conditions:**

$I_{set}$  High limit  $\leq 1$   
 $I_{set}$  Low limit low  $\leq 0$   
 $I_{set}$  Low limit high  $> 1$   
 $I$  ratio  $\leq 0$   
 $I_{unbalance}$  ratio  $> = 0$

Figure. 4.6.1 - 173. Secondary circuit fault in phase L1 wiring.

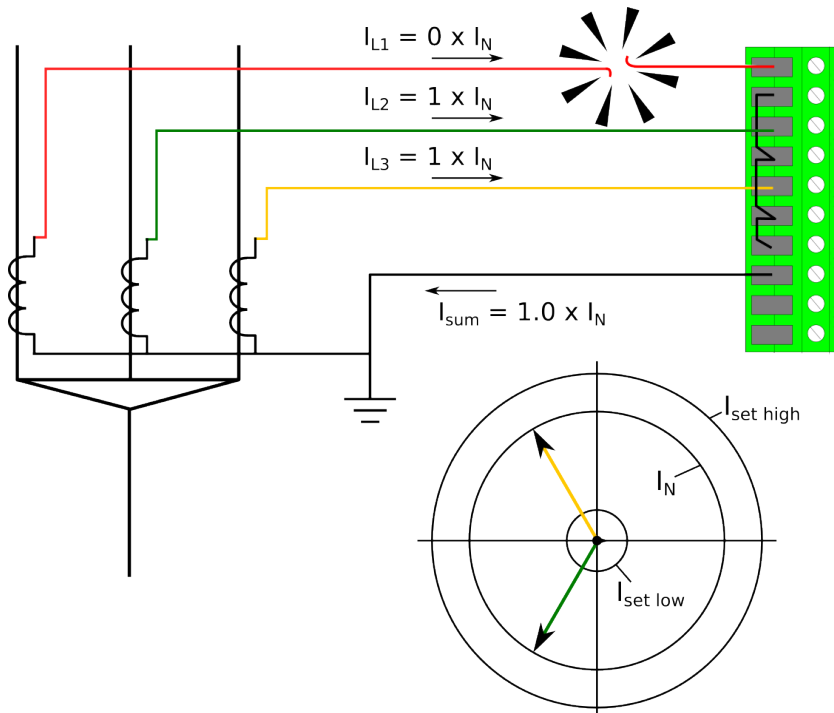

**Settings:**

$I_{set}$  High limit =  $1.20 \times I_N$   
 $I_{set}$  Low limit =  $0.10 \times I_N$   
 $I_{set}$  ratio = 10.00 %  
 $I1/I2$  ratio = 49.00 %  
 $I_0$  input = Not in use

**Measurements:**

$I_{min}$  =  $0 \times I_N$   
 $I_{max}$  =  $1 \times I_N$   
 $I1$  =  $0.67 \times I_N$   
 $I2$  =  $0.33 \times I_N$   
 $I_{min}/I_{max}$  = 0  
 $I2/I1$  = 50%

**CTS conditions:**

$I_{set}$  High limit  $\leq 1$   
 $I_{set}$  Low limit low  $\leq 1$   
 $I_{set}$  Low limit high  $> 1$   
 $I$  ratio  $\leq 1$   
 $I_{unbalance}$  ratio  $> = 1$

When a fault is detected and all conditions are met, the CTS timer starts counting. If the situation continues until the set time has passed, the function issues an alarm.

Figure. 4.6.1 - 174. Primary circuit fault in phase L1 wiring.

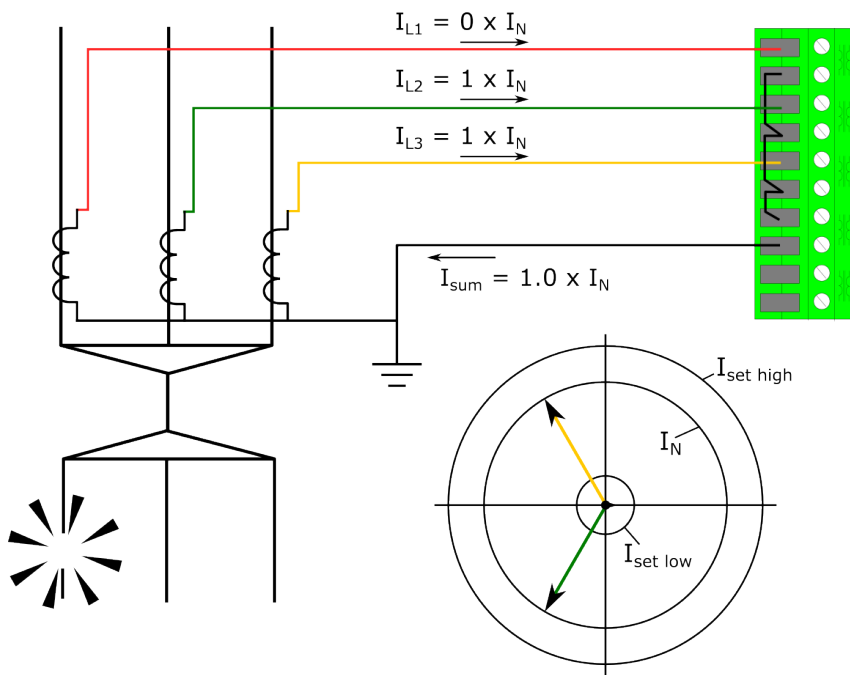

**Settings:**

$I_{set}$  High limit =  $1.20 \times I_N$   
 $I_{set}$  Low limit =  $0.10 \times I_N$   
 $I_{set}$  ratio = 10.00 %  
 I1/I2 ratio = 49.00 %  
 $I_0$  input = Not in use

**Measurements:**

$I_{min}$  =  $0 \times I_N$   
 $I_{max}$  =  $1 \times I_N$   
 $I1$  =  $0.67 \times I_N$   
 $I2$  =  $0.33 \times I_N$   
 $I_{min}/I_{max}$  = 0  
 $I2/I1$  = 50%

**CTS conditions:**

$I_{set}$  High limit  $\leq 1$   
 $I_{set}$  Low limit low  $\leq 1$   
 $I_{set}$  Low limit high  $> 1$   
 I ratio  $< 1$   
 $I_{unbalance}$  ratio  $> 1$

In this example, distinguishing between a primary fault and a secondary fault is impossible. However, the situation meets the function's activation conditions, and if this state (secondary circuit fault) continues until the set time has passed, the function issues an alarm. This means that the function supervises both the primary and the secondary circuit.

Figure. 4.6.1 - 175. No wiring fault but heavy unbalance.

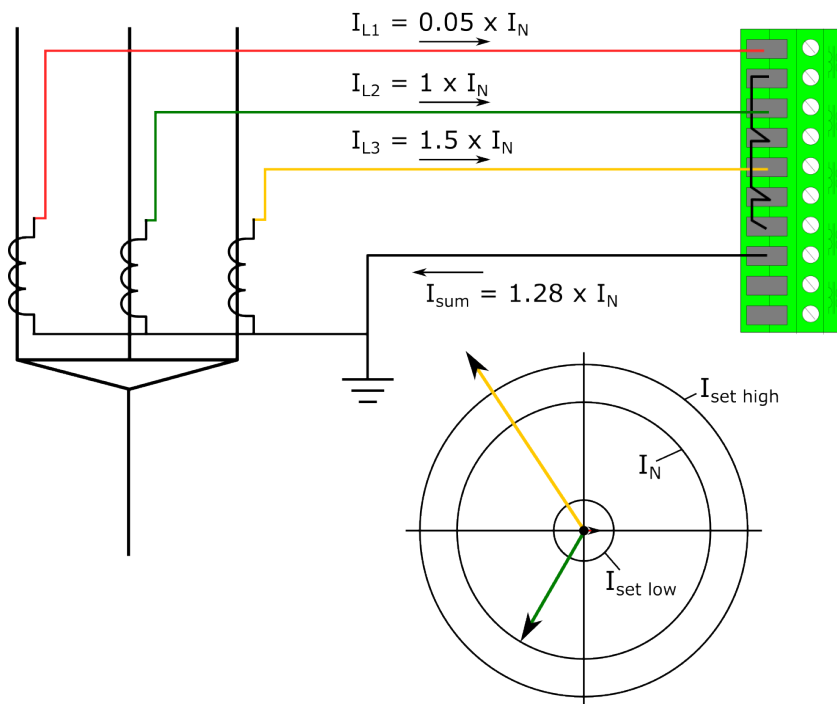

**Settings:**

$I_{set}$  High limit =  $1.20 \times I_N$   
 $I_{set}$  Low limit =  $0.10 \times I_N$   
 $I_{set}$  ratio = 10.00 %  
 I1/I2 ratio = 49.00 %  
 $I_0$  input = Not in use

**Measurements:**

$I_{min}$  =  $0.05 \times I_N$   
 $I_{max}$  =  $1.50 \times I_N$   
 $I1$  =  $0.85 \times I_N$   
 $I2$  =  $0.43 \times I_N$   
 $I_{min}/I_{max}$  = 0.7 %  
 $I2/I1$  = 50.03 %

**CTS conditions:**

$I_{set}$  High limit  $\leq 0$   
 $I_{set}$  Low limit low  $\leq 1$   
 $I_{set}$  Low limit high  $> 1$   
 I ratio  $\leq 1$   
 $I_{unbalance}$  ratio  $> 1$

If any of the phases exceed the  $I_{set}$  high limit setting, the operation of the function is not activated. This behavior is applied to short-circuits and earth faults even when the fault current exceeds the  $I_{set}$  high limit setting.

Figure. 4.6.1 - 176. Low current and heavy unbalance.

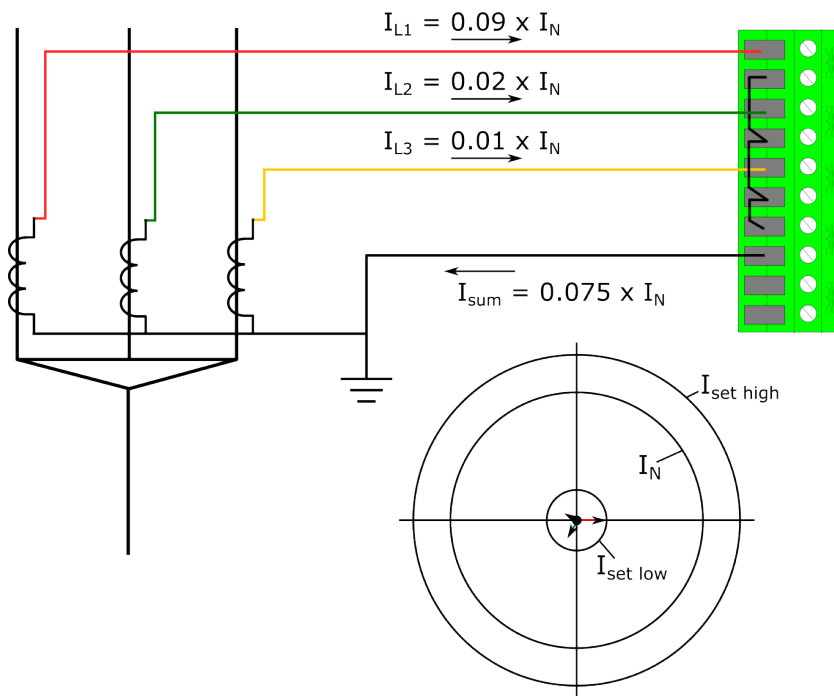

**Settings:**

- $I_{set}$  High limit =  $1.20 \times I_N$
- $I_{set}$  Low limit =  $0.10 \times I_N$
- $I_{set}$  ratio = 10.00 %
- I1/I2 ratio = 49.00 %
- $I_0$  input = Not in use

**Measurements:**

- $I_{min}$  =  $0.01 \times I_N$
- $I_{max}$  =  $0.09 \times I_N$
- I1 =  $0.04 \times I_N$
- I2 =  $0.03 \times I_N$
- $I_{min}/I_{max}$  = 11.0 %
- I2/I1 = 62.92 %

**CTS conditions:**

- $I_{set}$  High limit  $\leq 1$
- $I_{set}$  Low limit low  $\leq 1$
- $I_{set}$  Low limit high  $\geq 0$
- I ratio  $\leq 1$
- $I_{unbalance}$  ratio  $\geq 1$

If all of the measured phase magnitudes are below the  $I_{set}$  low limit setting, the function is not activated even when the other conditions (inc. the unbalance condition) are met.

If the  $I_{set}$  high limit and  $I_{set}$  low limit setting parameters are adjusted according to the application's normal behavior, the operation of the function can be set to be very sensitive for broken circuit and conductor faults.

Figure. 4.6.1 - 177. Normal situation, residual current also measured.

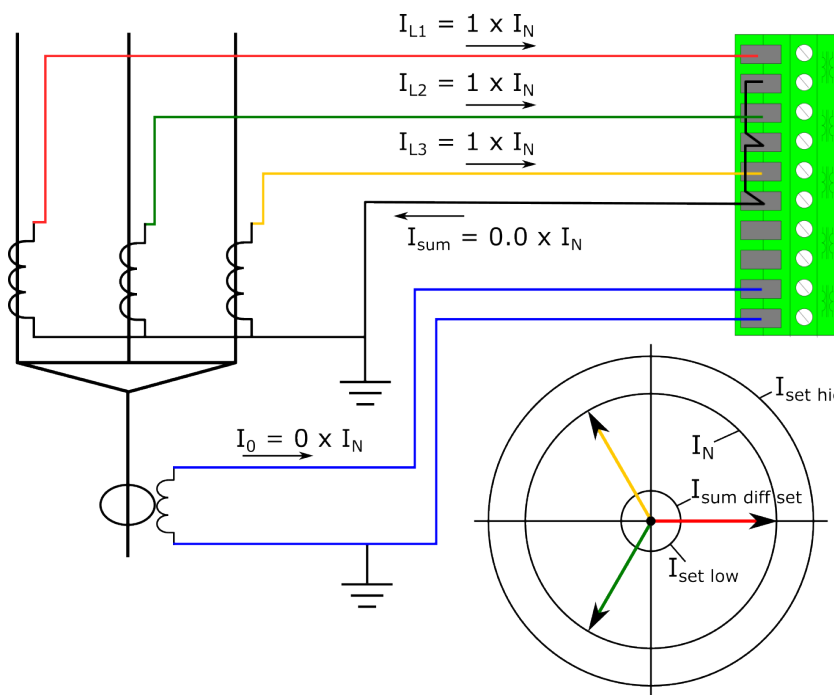

**Settings:**

- $I_{set}$  High limit =  $1.20 \times I_N$
- $I_{set}$  Low limit =  $0.10 \times I_N$
- $I_{set}$  ratio = 10.00 %
- I1/I2 ratio = 49.00 %
- $I_0$  input =  $I_{01}$
- $I_{sum}$  Difference =  $0.10 \times I_N$

**Measurements:**

- $I_{min}$  =  $1 \times I_N$
- $I_{max}$  =  $1 \times I_N$
- I1 =  $1 \times I_N$
- I2 =  $0 \times I_N$
- $I_{min}/I_{max}$  = 1
- I2/I1 = 0
- $I_{sum}$  Difference =  $0.0 \times I_N$

**CTS conditions:**

- $I_{set}$  High limit  $\leq 1$
- $I_{set}$  Low limit low  $\leq 0$
- $I_{set}$  Low limit high  $\geq 1$
- I ratio  $\leq 0$
- $I_{unbalance}$  ratio  $\geq 0$

When the residual condition is added with the "I0 input selection", the sum of the current and the residual current are compared against each other to verify the wiring condition.

Figure. 4.6.1 - 178. Broken secondary phase current wiring.

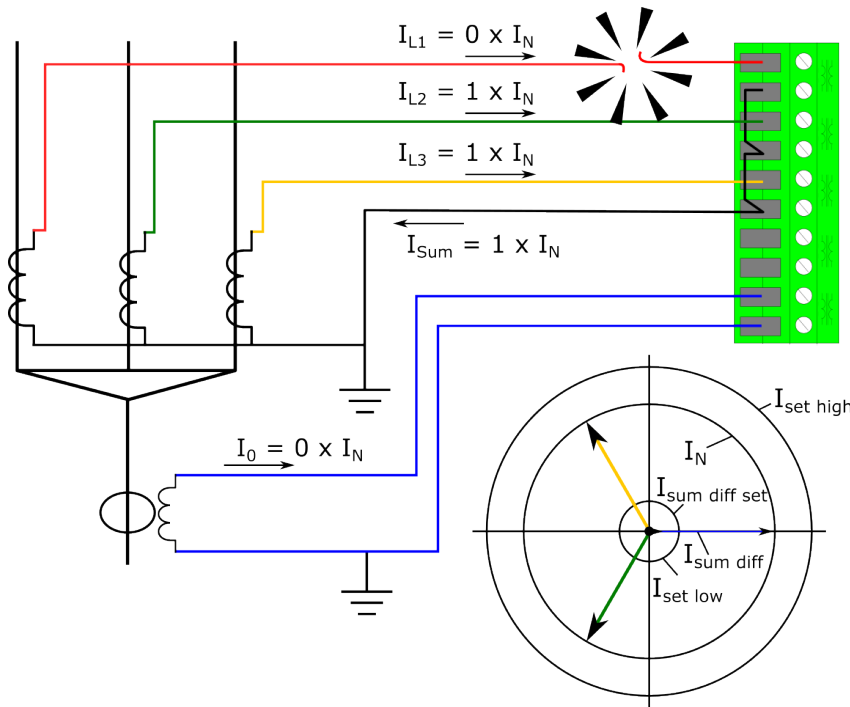

**Settings:**

- $I_{set}$  High limit =  $1.20 \times I_N$
- $I_{set}$  Low limit =  $0.10 \times I_N$
- $I_{set}$  ratio = 10.00 %
- I1/I2 ratio = 49.00 %
- $I_0$  input =  $I_{01}$
- $I_{sum}$  Difference =  $0.10 \times I_N$

**Measurements:**

- $I_{min}$  =  $1 \times I_N$
- $I_{max}$  =  $0 \times I_N$
- I1 =  $0.67 \times I_N$
- I2 =  $0.33 \times I_N$
- $I_{min}/I_{max}$  = 0
- I2/I1 = 50 %
- $I_{sum}$  Difference =  $1.0 \times I_N$

**CTS conditions:**

- $I_{set}$  High limit  $\leq 1$
- $I_{set}$  Low limit low  $\leq 1$
- $I_{set}$  Low limit high  $\geq 1$
- I ratio  $\leq 1$
- $I_{unbalance}$  ratio  $> 1$
- $I_{sum}$  Difference  $> 1$

When phase current wire is broken all of the conditions are met in the CTS and alarm shall be issued in case if the situation continues until the set alarming time is met.

Figure. 4.6.1 - 179. Broken primary phase current wiring.

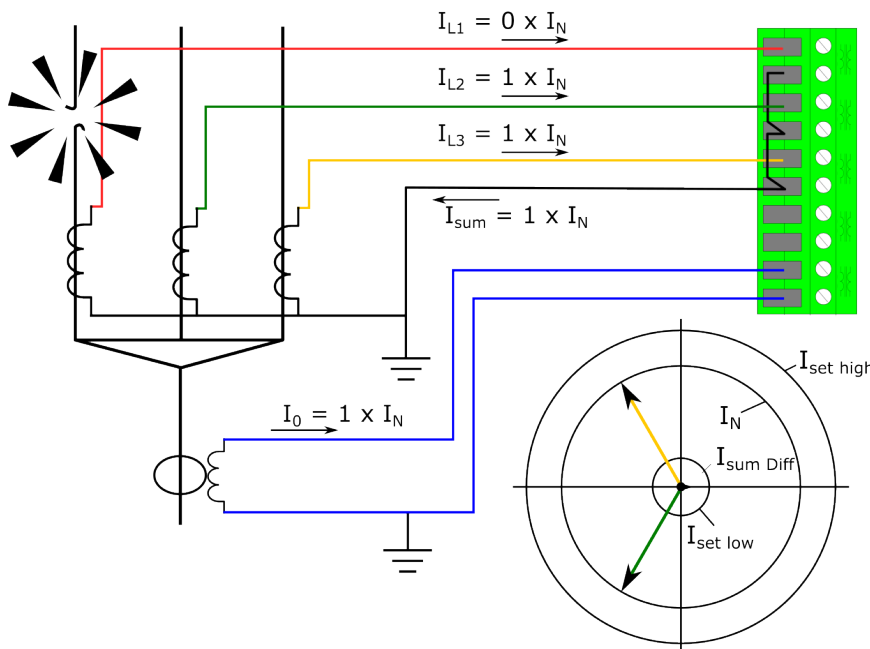

**Settings:**

- $I_{set}$  High limit =  $1.20 \times I_N$
- $I_{set}$  Low limit =  $0.10 \times I_N$
- $I_{set}$  ratio = 10.00 %
- I1/I2 ratio = 49.00 %
- $I_0$  input =  $I_{01}$
- $I_{sum}$  Difference =  $0.10 \times I_N$

**Measurements:**

- $I_{min}$  =  $0 \times I_N$
- $I_{max}$  =  $1 \times I_N$
- I1 =  $0.67 \times I_N$
- I2 =  $0.33 \times I_N$
- $I_{min}/I_{max}$  = 0
- I2/I1 = 50 %
- $I_{sum}$  Difference =  $0.0 \times I_N$

**CTS conditions:**

- $I_{set}$  High limit  $\leq 1$
- $I_{set}$  Low limit low  $\leq 1$
- $I_{set}$  Low limit high  $> 1$
- I ratio  $\leq 1$
- $I_{unbalance}$  ratio  $> 1$
- $I_{sum}$  Difference  $> 0$

In this example, all other condition are met except the residual difference. That is now  $0 \times I_N$ , which indicates a primary side fault.

Figure. 4.6.1 - 180. Primary side high-impedance earth fault.

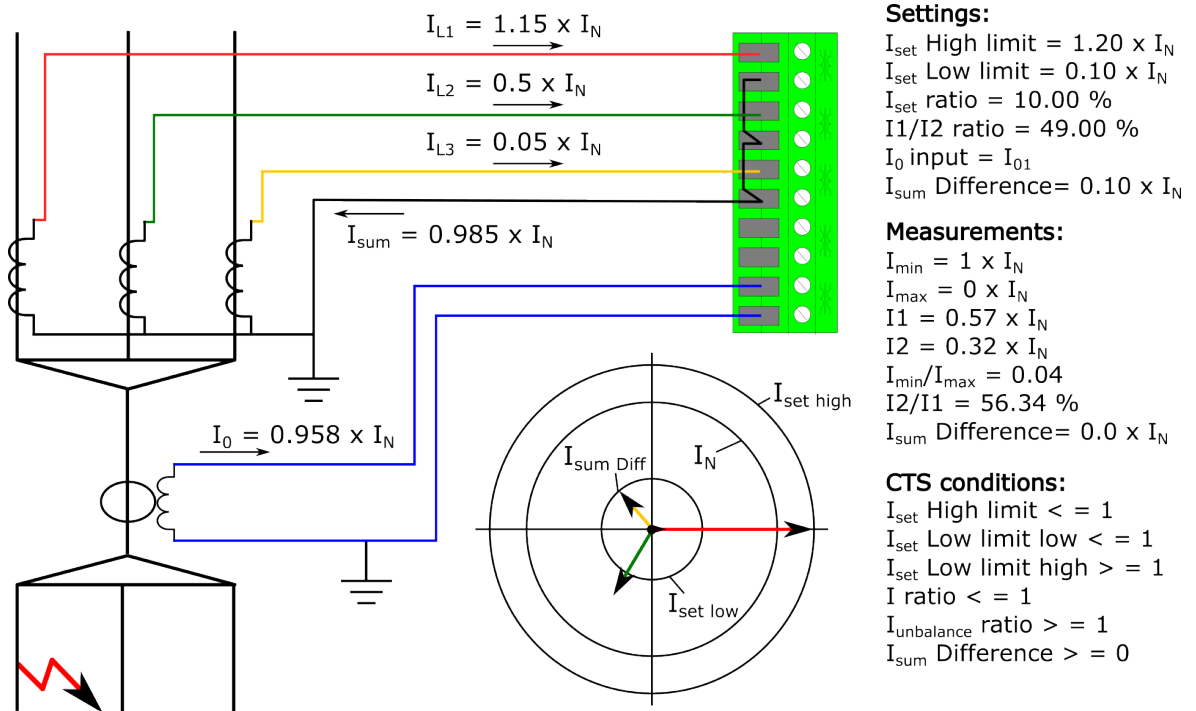

In this example there is a high-impedance earth fault. It does not activate the function, if the measurement conditions are met, while the calculated and measured residual current difference does not reach the limit. The  $I_{sum}$  difference setting should be set according to the application in order to reach maximum security and maximum sensitivity for the network earthing.

### Events and registers

The current transformer supervision function (abbreviated "CTS" in event block names) generates events and registers from the status changes in the events listed below. The user can select which event messages are stored in the main event buffer: ON, OFF, or both.

The function's outputs can be used for direct I/O controlling and user logic programming. The function also provides a resettable cumulative counter for the CTS ALARM and BLOCKED events.

Table. 4.6.1 - 306. Event messages.

| Event block name | Event names  |
|------------------|--------------|
| CTS1             | Alarm ON/OFF |
| CTS1             | Block ON/OFF |
| CTS2             | Alarm ON/OFF |
| CTS2             | Block ON/OFF |

The function registers its operation into the last twelve (12) time-stamped registers; this information is available for all provided instances separately. The register of the function records the ON event process data for ACTIVATED, BLOCKED, etc. The table below presents the structure of the function's register content.

Table. 4.6.1 - 307. Register content.

| Register             | Description   |
|----------------------|---|
| Date and time        | dd.mm.yyyy hh:mm:ss.mss   |
| Event                | Event name  |
| Trigger currents     | The phase currents (L1, L2 & L3), the residual currents (I01 & I02), and the sequence currents (I1 & I2) on trigger time. |
| Time to CTSact       | Time remaining before alarm activation.   |
| Fault type           | The status code of the monitored current.   |
| Setting group in use | Setting group 1...8 active  |

### 4.6.2 Voltage transformer supervision (60)

Voltage transformer supervision is used to detect errors in the secondary circuit of the voltage transformer wiring and during fuse failure. This signal is mostly used as an alarming function or to disable functions that require adequate voltage measurement.

Figure. 4.6.2 - 181. Secondary circuit fault in phase L1 wiring.

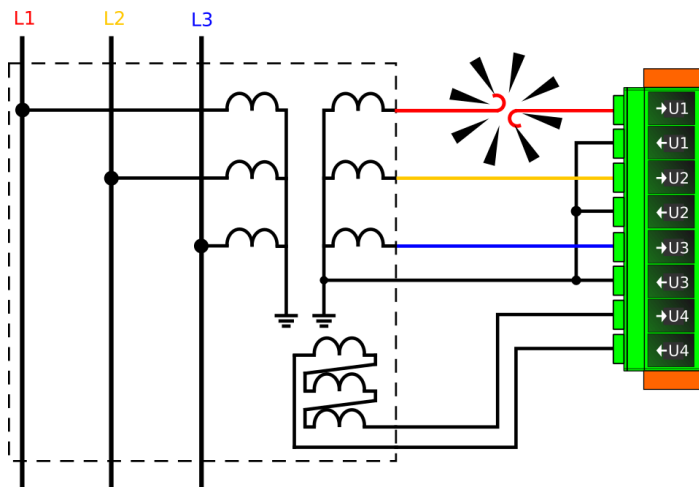
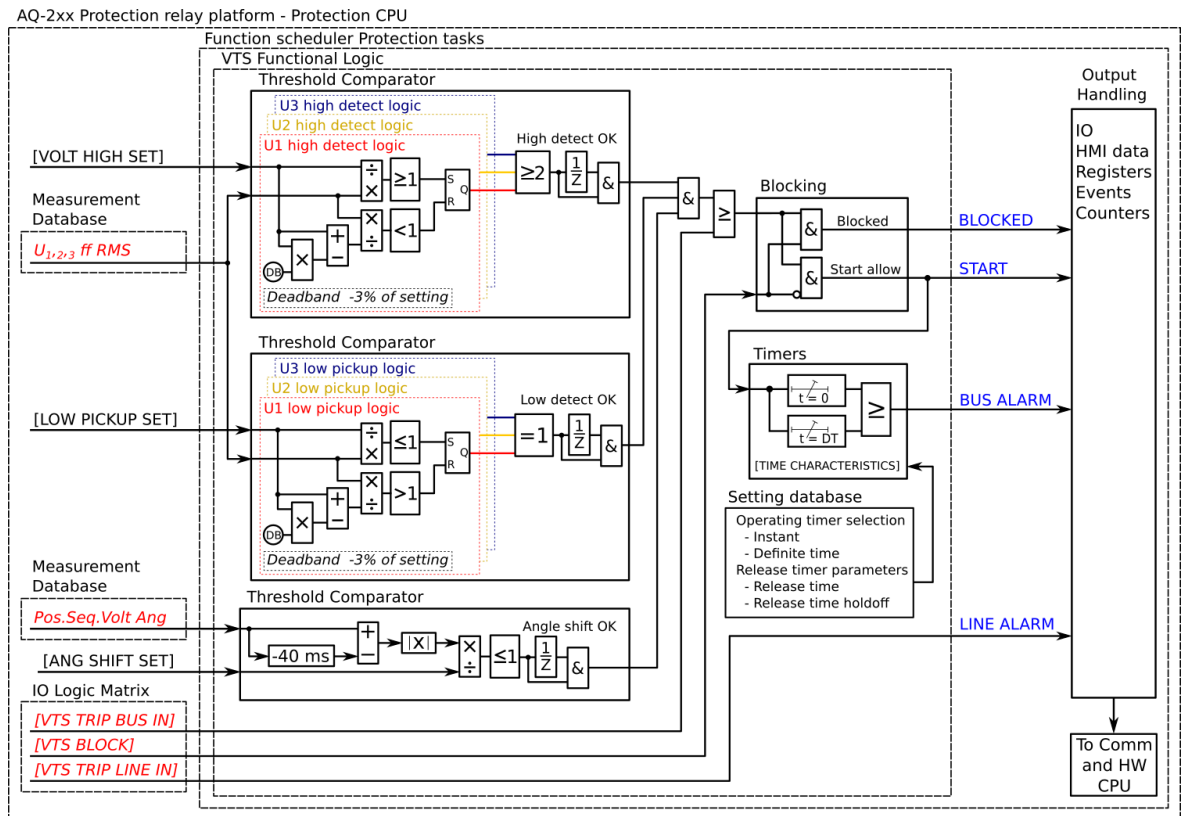

Figure. 4.6.2 - 182. Simplified function block diagram of the VTS function.



### Measured input

The function block uses fundamental frequency component of voltage measurement channels. The function uses calculated positive, negative and zero sequence voltages. The function also monitors the angle of each voltage channel.

Table. 4.6.2 - 308. Measurement inputs of the voltage transformer supervision function.

| Signal             | Description  |
|--------------------|--|
| U <sub>1</sub> RMS | Fundamental frequency component of U <sub>1</sub> /V voltage measurement |
| U <sub>2</sub> RMS | Fundamental frequency component of U <sub>2</sub> /V voltage measurement |
| U <sub>3</sub> RMS | Fundamental frequency component of U <sub>3</sub> /V voltage measurement |
| U <sub>4</sub> RMS | Fundamental frequency component of U <sub>4</sub> /V voltage measurement |

### General settings

The following general settings define the general behavior of the function. These settings are static i.e. it is not possible to change them by editing the setting group.

Table. 4.6.2 - 309. General settings of the function.

| Name                | Range   | Default | Description   |
|---------------------|---|---------|---|
| VTS LN mode         | <ul style="list-style-type: none"> <li>• On</li> <li>• Blocked</li> <li>• Test</li> <li>• Test/Blocked</li> <li>• Off</li> </ul>          | On      | Set mode of VTS block.<br>This parameter is visible only when <i>Allow setting of individual LN mode</i> is enabled in <i>General</i> menu. |
| VTS force status to | <ul style="list-style-type: none"> <li>• Normal</li> <li>• Start</li> <li>• VTLinefail</li> <li>• VTBusfail</li> <li>• Blocked</li> </ul> | Normal  | Force the status of the function. Visible only when <i>Enable stage forcing</i> parameter is enabled in <i>General</i> menu.                |

### Pick-up settings

The *Voltage low pick-up* and *Voltage high detect* setting parameters control the voltage-dependent pick-up and activation of the voltage transformer supervision function. The function's pick-up activates, if at least one of the three voltages is under the set *Voltage low pick-up* value, or if at least two of the three voltages exceed the set *Voltage high detect* value. The function constantly calculates the ratio between the setting values and the measured magnitude for each of the three phases.

Setting group selection controls the operating characteristics of the function, i.e. the user or user-defined logic can change function parameters while the function is running.

Table. 4.6.2 - 310. Pick-up settings.

| Name                 | Range   | Step              | Default           | Description  |
|----------------------|---|-------------------|-------------------|--|
| Voltage low pickup   | $0.05 \dots 0.50 \times U_n$  | $0.01 \times U_n$ | $0.05 \times U_n$ | If one the measured voltages is below low pickup value and two of the measured voltages exceed high detect value the function's pick-up activates.                                   |
| Voltage high detect  | $0.01 \dots 1.10 \times U_n$  | $0.01 \times U_n$ | $0.80 \times U_n$ |  |
| Angle shift limit    | $2.00 \dots 90.00 \text{deg}$   | $0.10 \text{deg}$ | $5.00 \text{deg}$ | If the difference between the present angle and the angle 40 ms before is above the set value, the function's pick-up is blocked.  |
| Bus fuse fail check  | <ul style="list-style-type: none"> <li>• No</li> <li>• Yes</li> </ul> | -                 | Yes               | Selects whether or not the state of the bus fuse is supervised. The supervised signal is determined the "VTS MCB Trip bus" setting ( <i>I/O</i> → <i>Fuse failure inputs</i> ).      |
| Line fuse fail check | <ul style="list-style-type: none"> <li>• No</li> <li>• Yes</li> </ul> | -                 | Yes               | Selects whether or not the state of the line fuse is supervised. The supervised signal is determined by the "VTS MCB Trip line" setting ( <i>I/O</i> → <i>Fuse failure inputs</i> ). |

The voltage transformer supervision can also report several different states of the measured voltage. These can be seen in the function's *INFO* menu.

| Name                      | Description   |
|---------------------------|---|
| Bus dead                  | No voltages.  |
| Bus Live VTS Ok           | All of the voltages are within the set limits.  |
| Bus Live VTS Ok SEQ Rev   | All of the voltages are within the set limits <b>BUT</b> the voltages are in a reversed sequence. |
| Bus Live VTS Ok SEQ Undef | Voltages are within the set limits <b>BUT</b> the sequence cannot be defined.                     |
| Bus Live VTS problem      | Any of the VTS pick-up conditions are met.  |

### Read-only parameters

The function's *Info* page displays useful, real-time information on the state of the protection function. It is accessed either through the device's HMI display, or through the setting tool software when it is connected to the device and its Live Edit mode is active.

Table. 4.6.2 - 311. Information displayed by the function.

| Name                    | Range  | Step   | Description  |
|-------------------------|--|--------|--|
| VTS LN behaviour        | <ul style="list-style-type: none"> <li>On</li> <li>Blocked</li> <li>Test</li> <li>Test/Blocked</li> <li>Off</li> </ul>   | -      | Displays the mode of VTS block.<br>This parameter is visible only when <i>Allow setting of individual LN mode</i> is enabled in <i>General</i> menu. |
| VTS condition           | <ul style="list-style-type: none"> <li>Normal</li> <li>Start</li> <li>VTLinfail</li> <li>VTBusfail</li> <li>Blocked</li> </ul>   | -      | Displays status of the monitoring function.  |
| Bus voltages            | <ul style="list-style-type: none"> <li>Bus dead</li> <li>Bus Live VTS Ok SEQ Ok</li> <li>Bus Live VTS Ok SEQ Rev</li> <li>Bus Live VTS Ok SEQ Undef</li> <li>Bus Live VTS problem</li> </ul> | -      | Displays the status of bus voltages.   |
| Expected operating time | 0.000...1800.000s  | 0.005s | Displays the expected operating time when a fault occurs.  |
| Time remaining to trip  | -1800.000...1800.000s  | 0.005s | When the function has detected a fault and counts down time towards a operation, this displays how much time is left before operation occurs.        |

## Function blocking

The block signal is checked in the beginning of each program cycle. The blocking signal is received from the blocking matrix in the function's dedicated input. If the blocking signal is not activated when the pick-up element activates, a START signal is generated and the function proceeds to the time characteristics calculation.

If the blocking signal is active when the pick-up element activates, a BLOCKED signal is generated and the function does not process the situation further. If the START function has been activated before the blocking signal, it resets and the release time characteristics are processed similarly to when the pick-up signal is reset.

The variables the user can set are binary signals from the system. The blocking signal needs to reach the device minimum of 5 ms before the set operating delay has passed in order for the blocking to activate in time.

## Operating time characteristics for activation

This function supports definite time delay (DT). For detailed information on these delay types please refer to the chapter "[General properties of a protection function](#)" and its section "[Operating time characteristics](#)".

## Events and registers

The voltage transformer supervision function (abbreviated "VTS" in event block names) generates events and registers from the status changes in the events listed below. The user can select which event messages are stored in the main event buffer: ON, OFF, or both. The events triggered by the function are recorded with a time stamp.

The function's outputs can be used for direct I/O controlling and user logic programming. The function also provides a resettable cumulative counter for the START, ALARM BUS, ALARM LINE and BLOCKED events.

Table. 4.6.2 - 312. Event messages.

| Event block name | Event names              |
|------------------|--------------------------|
| VTS1             | Bus VT fail Start ON/OFF |
| VTS1             | Bus VT fail Trip ON/OFF  |
| VTS1             | Bus VT fail Block ON/OFF |
| VTS1             | Line VT fail ON/OFF      |
| VTS1             | Bus Fuse fail ON/OFF     |
| VTS1             | Line Fuse fail ON/OFF    |

The function registers its operation into the last twelve (12) time-stamped registers. The register of the function records the ON event process data for ACTIVATED, BLOCKED, etc. The table below presents the structure of the function's register content.

Table. 4.6.2 - 313. Register content.

| Register                    | Description   |
|-----------------------------|---|
| Date and time               | dd.mm.yyyy hh:mm:ss.mss   |
| Event                       | Event name  |
| Volt 1, 2, 3, 4 status      | <ul style="list-style-type: none"> <li>No voltage</li> <li>Voltage OK</li> <li>Low voltage</li> </ul>   |
| System status               | <ul style="list-style-type: none"> <li>Bus dead</li> <li>Bus live, VTS OK, Seq. OK</li> <li>Bus live, VTS OK, Seq. reversed</li> <li>Bus live, VTS OK, Seq. undefined</li> <li>Bus live, VTS fault</li> </ul> |
| Input A, B, C, D angle diff | 0.00...360.00deg  |
| Trip time remaining         | Time remaining to alarm<br>0...1800s  |
| Setting group in use        | Setting group 1...8 active  |

### 4.6.3 Circuit breaker wear monitoring

The circuit breaker wear function is used for monitoring the circuit breaker's lifetime and its maintenance needs caused by interrupting currents and mechanical wear. The function uses the circuit breaker's manufacturer-supplied data for the breaker operating cycles in relation to the interrupted current magnitudes.

Figure. 4.6.3 - 183. Example of the circuit breaker interrupting life operations.

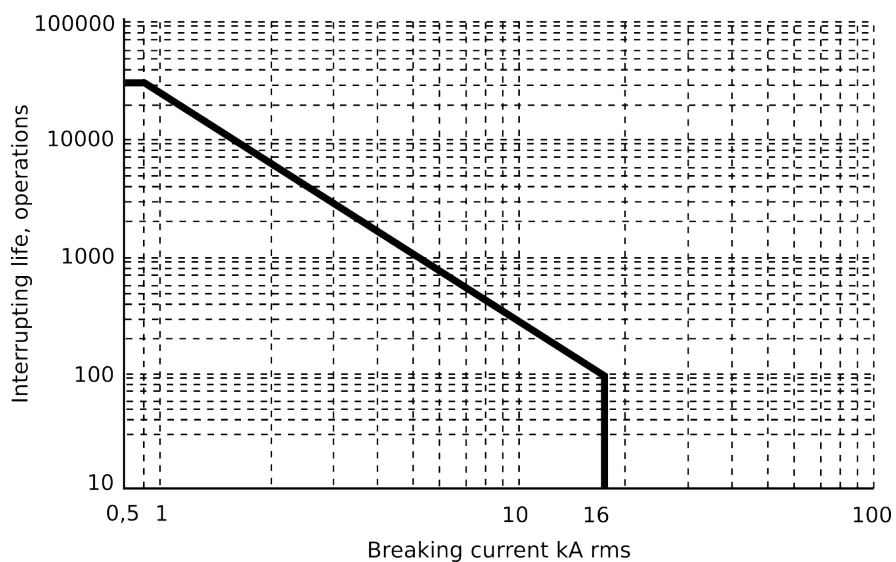

The function is triggered from the circuit breaker's "Open" command output and it monitors the three-phase current values in both the tripping moment and the normal breaker opening moment. The maximum value of interrupting life operations for each phase is calculated from these currents. The value is cumulatively deducted from the starting operations starting value. The user can set up two separate alarm levels, which are activated when the value of interrupting life operations is below the setting limit. The "Trip contact" setting defines the output that triggers the current monitoring at the breaker's "Open" command.

Figure. 4.6.3 - 184. Simplified function block diagram of the circuit breaker wear function.

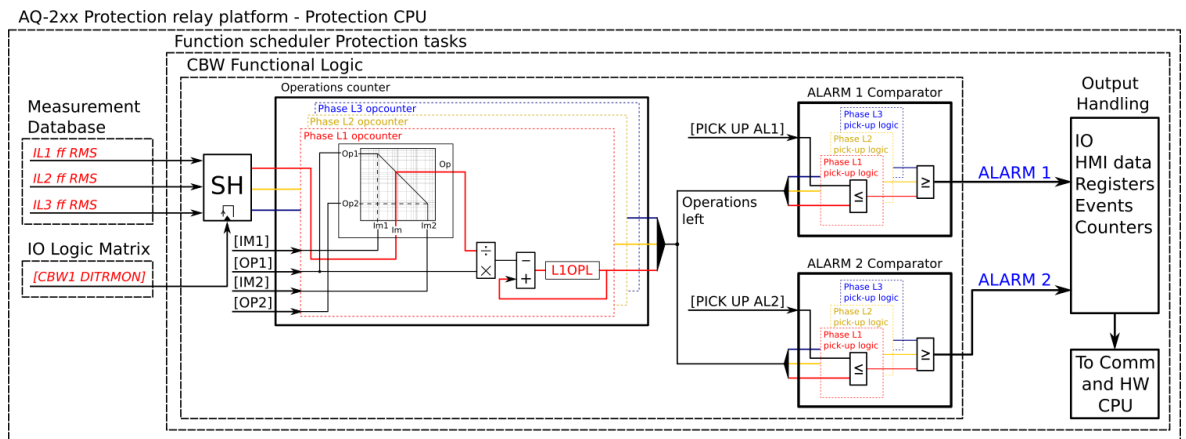

### Measured input

The function block uses fundamental frequency component of phase current measurement values.

Table. 4.6.3 - 314. Measurement inputs of the circuit breaker wear function.

| Signal      | Description   |
|-------------|---|
| $I_{L1RMS}$ | Fundamental frequency component of phase L1 (A) current |
| $I_{L2RMS}$ | Fundamental frequency component of phase L2 (B) current |
| $I_{L3RMS}$ | Fundamental frequency component of phase L3 (C) current |

### General settings

The following general settings define the general behavior of the function. These settings are static i.e. it is not possible to change them by switching the setting group.

Table. 4.6.3 - 315. General settings.

| Name        | Range  | Default | Description  |
|-------------|--|---------|--|
| CBW LN mode | <ul style="list-style-type: none"> <li>On</li> <li>Blocked</li> <li>Test</li> <li>Test/Blocked</li> <li>Off</li> </ul> | On      | Set mode of CBW block. This parameter is visible only when <i>Allow setting of individual LN mode</i> is enabled in <i>General</i> menu. |

| Name                | Range  | Default | Description  |
|---------------------|--|---------|--|
| CBW force status to | <ul style="list-style-type: none"> <li>Normal</li> <li>Alarm1 On</li> <li>Alarm2 On</li> </ul> | Normal  | Force the status of the function. Visible only when <i>Enable stage forcing</i> parameter is enabled in <i>General</i> menu. |
| CBW in side         | <ul style="list-style-type: none"> <li>Side 1</li> <li>Side 2</li> </ul>                       | Side 1  | Defines which current measurement module is used by the function.  |

### Circuit breaker characteristics settings

The circuit breaker characteristics are set by two operating points, defined by the nominal breaking current, the maximum allowed breaking current and their respective operation settings. This data is provided by the circuit breaker's manufacturer.

Table. 4.6.3 - 316. Settings for circuit breaker characteristics.

| Name                          | Range        | Step   | Default | Description   |
|-------------------------------|--------------|--------|---------|---|
| Operations 1                  | 0...200 000  | 1      | 50 000  | The number of interrupting life operations at the nominal current (Close - Open). |
| Operations 2                  | 0...200 000  | 1      | 100     | The number of interrupting life operations at the rated breaking current (Open).  |
| Current 1 (I <sub>nom</sub> ) | 0...100.00kA | 0.01kA | 1kA     | The rated normal current (RMS).   |
| Current 2 (I <sub>max</sub> ) | 0...100.00kA | 0.01kA | 20kA    | The rated short-circuit breaking current (RMS).                                   |

### Pick-up settings

For the alarm stages Alarm 1 and Alarm 2, the user can set the pick-up level for the number of operations left. The pick-up setting is common for all phases and the alarm stage picks up if any of the phases goes below this setting.

Table. 4.6.3 - 317. Pick-up settings.

| Name        | Range   | Default  | Description   |
|-------------|---|----------|---|
| Alarm 1     | <ul style="list-style-type: none"> <li>Disabled</li> <li>Enabled</li> </ul> | Disabled | Enable and disable the Alarm 1 stage.   |
| Alarm 1 Set | 0...200 000   | 1 000    | Defines the pick-up threshold for remaining operations. When the number of remaining operations is below this setting, the ALARM 1 signal is activated. |
| Alarm 2     | <ul style="list-style-type: none"> <li>Disabled</li> <li>Enabled</li> </ul> | Disabled | Enable and disable the Alarm 2 stage.   |
| Alarm 2 Set | 0...200 000   | 100      | Defines the pick-up threshold for remaining operations. When the number of remaining operations is below this setting, the ALARM 2 signal is activated. |

## Setting example

Let us examine the settings, using a low-duty vacuum circuit breaker as an example. The image below presents the technical specifications provided by the manufacturer, with the data relevant to our settings highlighted in red:

|   |            |
|---|------------|
| Rated voltage, kV   | 24         |
| Rated current, A  | 800        |
| Rated power frequency test voltage, kV                                      | 50         |
| Rated frequency, Hz   | 50/60      |
| Rated impulse test voltage, kV peak   | 125        |
| Partial discharge level at 1,1 rated voltage kV, pC                         | <10        |
| Rated short-circuit breaking current, kA                                    | 16         |
| Rated short-circuit making current, kA peak                                 | 41.5       |
| Short time withstand current, 4s, kA  | 16         |
| Mechanical life, CO cycles, not less than                                   | 30,000     |
| Interrupting life operations, not less than                                 |            |
| at rated current  | 30,000     |
| at breaking current   | 100        |
| at other currents   | see Fig.41 |
| Closing time, ms, not more than   | 35         |
| Opening time, ms, not more than   | 15         |
| Breaking time, ms, not more than  | 25         |
| Main contact resistance, $\mu\Omega$ , not more than                        | 40         |
| Maximum ambient temperature, C°   | +55        |
| Minimum ambient temperature, C°   | -40        |
| Design class (according to IEC 60932)                                       | 1          |
| Electrical endurance class at rated IEEE/IEC duty                           | E2         |
| Mechanical endurance class at rated IEEE/IEC duty                           | M2         |
| Capacitive current switching class  | C2         |
| "Mechanical vibration and shock withstand capability, IEC 60721, IEC 60068" | Class 4M4  |
| Maximum altitude above sea level, m   | 3000*      |
| Maximum humidity, non condensing  | 98 %       |
| Weight, kg - LD_1   | 35         |
| Weight, kg - LD_6   | 55         |

Now, we set the stage as follows:

| Parameter      | Setting           |
|----------------|-------------------|
| Current 1      | 0.80 kA           |
| Operation 1    | 30 000 operations |
| Current 2      | 16.00 kA          |
| Operations 2   | 100 operations    |
| Enable Alarm 1 | Enabled           |

| Parameter      | Setting         |
|----------------|-----------------|
| Alarm 1 Set    | 1000 operations |
| Enable Alarm 2 | Enabled         |
| Alarm 2 Set    | 100 operations  |

With these settings, Alarm 1 is issued when the cumulative interruption counter for any of the three phases dips below the set 1000 remaining operations ("Alarm 1 Set"). Similarly, when any of the counters dips below 100 remaining operations, Alarm 2 is issued.

### Read-only parameters

The function's *Info* page displays useful, real-time information on the state of the protection function. It is accessed either through the device's HMI display, or through the setting tool software when it is connected to the device and its Live Edit mode is active.

Table. 4.6.3 - 318. Information displayed by the function.

| Name               | Range  | Description  |
|--------------------|--|--|
| CBW LN behaviour   | <ul style="list-style-type: none"> <li>• On</li> <li>• Blocked</li> <li>• Test</li> <li>• Test/Blocked</li> <li>• Off</li> </ul> | Displays the mode of CBW block.<br>This parameter is visible only when <i>Allow setting of individual LN mode</i> is enabled in <i>General</i> menu. |
| CBW condition      | <ul style="list-style-type: none"> <li>• Normal</li> <li>• Alarm1 On</li> <li>• Alarm2 On</li> </ul>                             | Displays the status of the function.   |
| Breaker operations | -  | Cumulative counter of "open" operations.   |
| Alarm 1 counter    | -  | Alarm 1 operation counter.   |
| Alarm 2 counter    | -  | Alarm 2 operation counter.   |
| L1 Operations left | -  | Operations left for phase L1.  |
| L2 Operations left | -  | Operations left for phase L2.  |
| L3 Operations left | -  | Operations left for phase L3.  |

## Events and registers

The circuit breaker wear function (abbreviated "CBW" in event block names) generates events and registers from the status changes in the events listed below. The user can select which event messages are stored in the main event buffer: ON, OFF, or both. The function's outputs can be used for direct I/O controlling and user logic programming. The events triggered by the function are recorded with a time stamp.

The function also provides a resettable cumulative counter for the "Open" operations as well as the ALARM 1 and ALARM 2 events.

Table. 4.6.3 - 319. Event messages.

| Event block name | Event names            |
|------------------|------------------------|
| CBW1             | CBWEAR1 Triggered      |
| CBW1             | CBWEAR1 Alarm 1 ON/OFF |
| CBW1             | CBWEAR1 Alarm 2 ON/OFF |

The function registers its operation into the last twelve (12) time-stamped registers. The register of the function records the ON event process data. The table below presents the structure of the function's register content.

Table. 4.6.3 - 320. Register content.

| Register        | Description  |
|-----------------|--|
| Date and time   | dd.mm.yyyy hh:mm:ss.mss                              |
| Event           | Event name   |
| Trigger current | Phase currents on trigger time                       |
| Deducted Op     | L1/L2/L3 Deducted operations from the cumulative sum |
| Operations left | L1/L2/L3 Operations left                             |

### 4.6.4 Current total harmonic distortion (THD)

The total harmonic distortion (THD) function is used for monitoring the content of the current harmonic. The THD is a measurement of the harmonic distortion present, and it is defined as the ratio between the sum of all harmonic components' powers and the power of the fundamental frequency (RMS).

Harmonics can be caused by different sources in electric networks such as electric machine drives, thyristor controls, etc. The function's monitoring of the currents can be used to alarm of the harmonic content rising too high; this can occur when there is an electric quality requirement in the protected unit, or when the harmonics generated by the process need to be monitored.

The function constantly measures the phase and residual current magnitudes as well as the harmonic content of the monitored signals up to the 31<sup>st</sup> harmonic component. When the function is activated, the measurements are also available for the mimic and the measurement views in the HMI carousel. The user can also set the alarming limits for each measured channel if the application so requires.

The monitoring of the measured signals can be selected to be based either on an amplitude ratio or on the above-mentioned power ratio. The difference is in the calculation formula (as shown below):

Figure. 4.6.4 - 185. THD calculation formulas.

$$THD_P = \frac{I_{x2}^2 + I_{x3}^2 + I_{x4}^2 \dots I_{x31}^2}{I_{x1}^2}$$

, where  
I = measured current,  
x= measurement input,  
n = harmonic number

$$THD_A = \sqrt{\frac{I_{x2}^2 + I_{x3}^2 + I_{x4}^2 \dots I_{x31}^2}{I_{x1}^2}}$$

, where  
I = measured current,  
x= measurement input,  
n = harmonic number

While both of these formulas exist, the power ratio ( $THD_P$ ) is recognized by the IEEE, and the amplitude ratio ( $THD_A$ ) is recognized by the IEC.

Figure. 4.6.4 - 186. Simplified function block diagram of the total harmonic distortion monitor function.

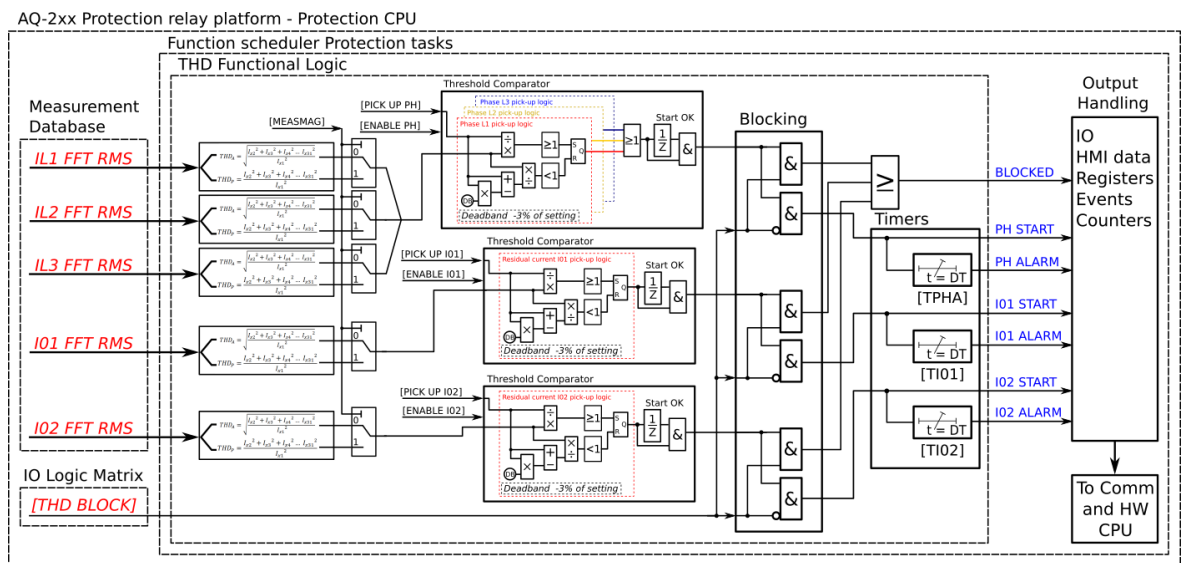

### Measured input

The function block uses phase and residual current measurement channels. The function always uses FFT measurement of the whole harmonic spectrum of 32 components from each measured current channel. From these measurements the function calculates either the amplitude ratio or the power ratio.

Table. 4.6.4 - 321. Measurement inputs of the total harmonic distortion monitor function.

| Signal | Description                             |
|--------|---|
| IL1FFT | FFT measurement of phase L1 (A) current |
| IL2FFT | FFT measurement of phase L2 (B) current |
| IL3FFT | FFT measurement of phase L3 (C) current |
| IO1FFT | FFT measurement of residual IO1 current |
| IO2FFT | FFT measurement of residual IO2 current |

The selection of the calculation method is made with a setting parameter (common for all measurement channels).

## General settings

The following general settings define the general behavior of the function. These settings are static i.e. it is not possible to change them by editing the setting group.

Table. 4.6.4 - 322. General settings.

| Name                  | Range  | Default   | Description   |
|-----------------------|--|-----------|---|
| THD> LN mode          | <ul style="list-style-type: none"> <li>• On</li> <li>• Blocked</li> <li>• Test</li> <li>• Test/Blocked</li> <li>• Off</li> </ul> | On        | Set mode of THD block.<br>This parameter is visible only when <i>Allow setting of individual LN mode</i> is enabled in <i>General</i> menu. |
| THD> in side          | <ul style="list-style-type: none"> <li>• CT1</li> <li>• CT2</li> </ul>   | CT1       | Defines which current measurement module the function uses.   |
| Measurement magnitude | <ul style="list-style-type: none"> <li>• Amplitude</li> <li>• Power</li> </ul>   | Amplitude | Defines which available measured magnitude the function uses.   |

## Pick-up settings

The  $Phase_{THD}$ ,  $I01_{THD}$  and  $I02_{THD}$  setting parameters control the the pick-up and activation of the function. They define the maximum allowed measured current THD before action from the function. Before the function activates alarm signals, their corresponding pick-up elements need to be activated with the setting parameters *Enable phase THD alarm*, *Enable I01 THD alarm* and *Enable I02 THD alarm*. The function constantly calculates the ratio between the setting values and the calculated THD for each of the three phases. The reset ratio of 97 % is built into the function and is always relative to the setting value. The setting value is common for all measured phases. When the calculated THD exceeds the pick-up value (in single, dual or all phases), it triggers the pick-up operation of the function.

Setting group selection controls the operating characteristics of the function, i.e. the user or user-defined logic can change function parameters while the function is running.

Table. 4.6.4 - 323. Pick-up settings.

| Name                   | Range   | Step | Default | Description  |
|------------------------|---|------|---------|--|
| Enable phase THD alarm | <ul style="list-style-type: none"> <li>• Enabled</li> <li>• Disabled</li> </ul> | -    | Enabled | Enables and disables the THD alarm function from phase currents.             |
| Enable I01 THD alarm   | <ul style="list-style-type: none"> <li>• Enabled</li> <li>• Disabled</li> </ul> | -    | Enabled | Enables and disables the THD alarm function from residual current input I01. |

| Name                 | Range   | Step  | Default | Description   |
|----------------------|---|-------|---------|---|
| Enable I02 THD alarm | <ul style="list-style-type: none"> <li>Enabled</li> <li>Disabled</li> </ul> | -     | Enabled | Enables and disables the THD alarm function from residual current input I02.  |
| Phase THD pick-up    | 0.10...100.00%  | 0.01% | 10.00%  | The pick-up setting for the THD alarm element from the phase currents. At least one of the phases' measured THD value has to exceed this setting in order for the alarm signal to activate. |
| I01 THD pick-up      | 0.10...100.00%  | 0.01% | 10.00%  | The pick-up setting for the THD alarm element from the residual current I01. The measured THD value has to exceed this setting in order for the alarm signal to activate.                   |
| I02 THD pick-up      | 0.10...100.00%  | 0.01% | 10.00%  | The pick-up setting for the THD alarm element from the residual current I02. The measured THD value has to exceed this setting in order for the alarm signal to activate.                   |

### Read-only parameters

The function's *Info* page displays useful, real-time information on the state of the protection function. It is accessed either through the device's HMI display, or through the setting tool software when it is connected to the device and its Live Edit mode is active.

Table. 4.6.4 - 324. Information displayed by the function.

| Name              | Range  | Description   |
|-------------------|--|---|
| THD> LN behaviour | <ul style="list-style-type: none"> <li>On</li> <li>Blocked</li> <li>Test</li> <li>Test/Blocked</li> <li>Off</li> </ul> | <p>Displays the mode of THD block.</p> <p>This parameter is visible only when <i>Allow setting of individual LN mode</i> is enabled in <i>General</i> menu.</p> |
| THD condition     | <ul style="list-style-type: none"> <li>Normal</li> <li>Start</li> <li>Alarm</li> <li>Blocked</li> </ul>                | Displays status of the monitoring function.   |

### Function blocking

The block signal is checked in the beginning of each program cycle. The blocking signal is received from the blocking matrix in the function's dedicated input. If the blocking signal is not activated when the pick-up element activates, a START signal is generated and the function proceeds to the time characteristics calculation.

If the blocking signal is active when the pick-up element activates, a BLOCKED signal is generated and the function does not process the situation further. If the START function has been activated before the blocking signal, it resets and the release time characteristics are processed similarly to when the pick-up signal is reset.

The variables the user can set are binary signals from the system. The blocking signal needs to reach the device minimum of 5 ms before the set operating delay has passed in order for the blocking to activate in time.

## Operating time characteristics for activation and reset

This function supports definite time delay (DT). The following table presents the setting parameters for the function's time characteristics.

Table. 4.6.4 - 325. Settings for operating time characteristics.

| Name                  | Range             | Step   | Default | Description   |
|-----------------------|-------------------|--------|---------|---|
| Phase THD alarm delay | 0.000...1800.000s | 0.005s | 10.000s | Defines the delay for the alarm timer from the phase currents' measured THD.        |
| I01 THD alarm delay   | 0.000...1800.000s | 0.005s | 10.000s | Defines the delay for the alarm timer from the residual current I01's measured THD. |
| I02 THD alarm delay   | 0.000...1800.000s | 0.005s | 10.000s | Defines the delay for the alarm timer from the residual current I02's measured THD. |

## Events and registers

The total harmonic distortion monitor function (abbreviated "THD" in event block names) generates events and registers from the status changes in the events listed below. The user can select which event messages are stored in the main event buffer: ON, OFF, or both. The events triggered by the function are recorded with a time stamp.

The function's outputs can be used for direct I/O controlling and user logic programming. The function also provides a resettable cumulative counter for the START, ALARM and BLOCKED events.

Table. 4.6.4 - 326. Event messages.

| Event block name | Event names            |
|------------------|------------------------|
| THD1             | THD Start Phase ON/OFF |
| THD1             | THD Start I01 ON/OFF   |
| THD1             | THD Start I02 ON/OFF   |
| THD1             | THD Alarm Phase ON/OFF |
| THD1             | THD Alarm I01 ON/OFF   |
| THD1             | THD Alarm I02 ON/OFF   |
| THD1             | Blocked ON/OFF         |

The function registers its operation into the last twelve (12) time-stamped registers. The register of the function records the ON event process data for START, ALARM and BLOCKED. The table below presents the structure of the function's register content.

Table. 4.6.4 - 327. Register content.

| Register      | Description             |
|---------------|-------------------------|
| Date and time | dd.mm.yyyy hh:mm:ss.mss |
| Event         | Event name              |

| Register                | Description                    |
|-------------------------|--------------------------------|
| L1h, L2h, L3h Fault THD | Start/Alarm THD of each phase. |
| Setting group in use    | Setting group 1...8 active.    |

### 4.6.5 Voltage total harmonic distortion (THD)

The voltage total harmonic distortion (THD) function is used for monitoring the content of the voltage harmonic. The THD is a measurement of the harmonic distortion present, and it is defined as the ratio between the sum of all harmonic components' powers and the power of the fundamental frequency (RMS).

Harmonics can be caused by different sources in electric networks such as electric machine drives, thyristor controls, etc. The function's monitoring of the voltage can be used to alarm of the harmonic content rising too high; this can occur when there is an electric quality requirement in the protected unit, or when the harmonics generated by the process need to be monitored.

The function constantly measures the phase voltage magnitudes as well as the harmonic content of the monitored signals up to the 31<sup>st</sup> harmonic component. The user can set the alarming limits if the application so requires.

The monitoring of the measured signals can be selected to be based either on an amplitude ratio or on the above-mentioned power ratio. The difference is in the calculation formula (as shown below):

Figure. 4.6.5 - 187. THD calculation formulas.

$$THD_P = \frac{U_{x2}^2 + U_{x3}^2 + U_{x4}^2 \dots U_{x31}^2}{U_{x1}^2}$$

, where  
U = measured voltage,  
x= measurement input,  
n = harmonic number

  

$$THD_A = \sqrt{\frac{U_{x2}^2 + U_{x3}^2 + U_{x4}^2 \dots U_{x31}^2}{U_{x1}^2}}$$

, where  
U = measured voltage,  
x= measurement input,  
n = harmonic number

While both of these formulas exist, the power ratio (*THD<sub>P</sub>*) is recognized by the IEEE, and the amplitude ratio (*THD<sub>A</sub>*) is recognized by the IEC.

Figure. 4.6.5 - 188. Simplified function block diagram of the total harmonic distortion monitor function.

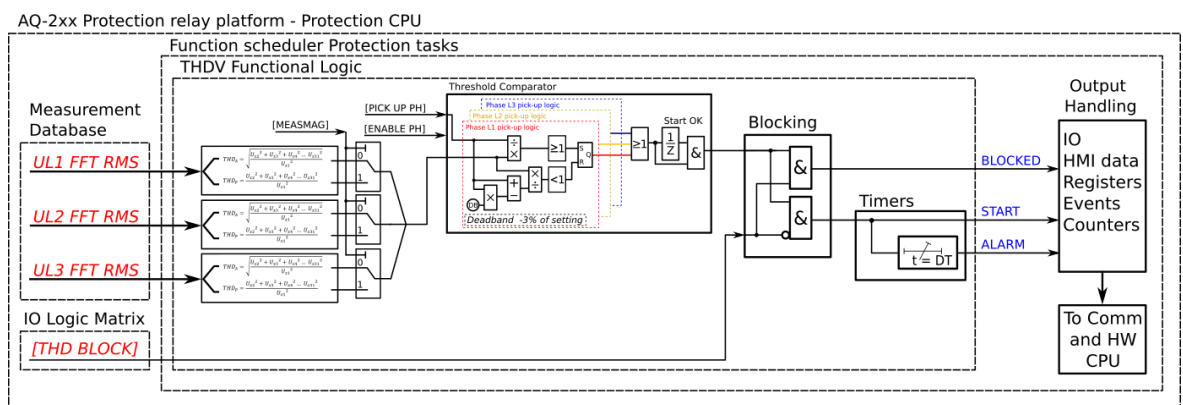

## Measured input

The function block uses analog voltage measurement values. The function always uses FFT measurement of the whole harmonic specter of 32 components from each measured voltage channel. From these measurements the function calculates either the amplitude ratio or the power ratio.

Table. 4.6.5 - 328. Measurement inputs of the total harmonic distortion monitor function.

| Signal             | Description  |
|--------------------|--|
| U <sub>1</sub> FFT | FFT measurement of U <sub>1</sub> /V voltage channel |
| U <sub>2</sub> FFT | FFT measurement of U <sub>2</sub> /V voltage channel |
| U <sub>3</sub> FFT | FFT measurement of U <sub>3</sub> /V voltage channel |

The selection of the calculation method is made with a setting parameter (common for all measurement channels).

## General settings

The following general settings define the general behavior of the function. These settings are static i.e. it is not possible to change them by editing the setting group.

Table. 4.6.5 - 329. General settings.

| Name                  | Range  | Default   | Description   |
|-----------------------|--|-----------|---|
| THDV> LN mode         | <ul style="list-style-type: none"> <li>On</li> <li>Blocked</li> <li>Test</li> <li>Test/Blocked</li> <li>Off</li> </ul> | On        | Set mode of THDV block. This parameter is visible only when <i>Allow setting of individual LN mode</i> is enabled in <i>General</i> menu. |
| Measurement magnitude | <ul style="list-style-type: none"> <li>Amplitude</li> <li>Power</li> </ul>   | Amplitude | Defines which available measured magnitude the function uses.   |

## Pick-up settings

The THDV pick-up setting parameter controls the the pick-up and activation of the function. They define the maximum allowed measured voltage THD before action from the function. Before the function activates alarm signals, their corresponding pick-up elements need to be activated with the setting parameter *Enable THD alarm*. The function constantly calculates the ratio between the setting values and the calculated voltage THD. The reset ratio of 97 % is built into the function and is always relative to the setting value. The setting value is common for all measured phases. When the calculated THD exceeds the pick-up value (in single, dual or all phases), it triggers the pick-up operation of the function.

Setting group selection controls the operating characteristics of the function, i.e. the user or user-defined logic can change function parameters while the function is running.

Table. 4.6.5 - 330. Pick-up settings.

| Name              | Range   | Step  | Default | Description   |
|-------------------|---|-------|---------|---|
| Enable THDV alarm | <ul style="list-style-type: none"> <li>Enabled</li> <li>Disabled</li> </ul> | -     | Enabled | Enables and disables the THD alarm function.  |
| THDV pick-up      | 0.10...100.00%  | 0.01% | 10.00%  | The pick-up setting for the THD alarm element from the phase voltages. At least one of the phases' measured THD value has to exceed this setting in order for the alarm signal to activate. |

### Read-only parameters

The function's *Info* page displays useful, real-time information on the state of the protection function. It is accessed either through the device's HMI display, or through the setting tool software when it is connected to the device and its Live Edit mode is active.

Table. 4.6.5 - 331. Information displayed by the function.

| Name               | Range  | Description   |
|--------------------|--|---|
| THDV> LN behaviour | <ul style="list-style-type: none"> <li>On</li> <li>Blocked</li> <li>Test</li> <li>Test/Blocked</li> <li>Off</li> </ul> | Displays the mode of THDV block.<br>This parameter is visible only when <i>Allow setting of individual LN mode</i> is enabled in <i>General</i> menu. |
| THDV condition     | <ul style="list-style-type: none"> <li>Normal</li> <li>Start</li> <li>Alarm</li> <li>Blocked</li> </ul>                | Displays status of the monitoring function.   |

### Function blocking

The block signal is checked in the beginning of each program cycle. The blocking signal is received from the blocking matrix in the function's dedicated input. If the blocking signal is not activated when the pick-up element activates, a START signal is generated and the function proceeds to the time characteristics calculation.

If the blocking signal is active when the pick-up element activates, a BLOCKED signal is generated and the function does not process the situation further. If the START function has been activated before the blocking signal, it resets and the release time characteristics are processed similarly to when the pick-up signal is reset.

The variables the user can set are binary signals from the system. The blocking signal needs to reach the device minimum of 5 ms before the set operating delay has passed in order for the blocking to activate in time.

### Operating time characteristics for activation and reset

This function supports definite time delay (DT). The following table presents the setting parameters for the function's time characteristics.

Table. 4.6.5 - 332. Settings for operating time characteristics.

| Name             | Range             | Step   | Default | Description  |
|------------------|-------------------|--------|---------|--|
| THDV alarm delay | 0.000...1800.000s | 0.005s | 10.000s | Defines the delay for the alarm timer from the phase voltages' measured THD. |

## Events and registers

The voltage total harmonic distortion monitor function (abbreviated "THDV" in event block names) generates events and registers from the status changes in the events listed below. The user can select which event messages are stored in the main event buffer: ON, OFF, or both. The events triggered by the function are recorded with a time stamp.

The function's outputs can be used for direct I/O controlling and user logic programming. The function also provides a resettable cumulative counter for the START, ALARM and BLOCKED events.

Table. 4.6.5 - 333. Event messages.

| Event block name | Event names              |
|------------------|--------------------------|
| THDV1            | Voltage THD Start ON/OFF |
| THDV1            | Voltage THD Alarm ON/OFF |
| THDV1            | Voltage Blocked ON/OFF   |

The function registers its operation into the last twelve (12) time-stamped registers. The register of the function records the ON event process data for START, ALARM and BLOCKED. The table below presents the structure of the function's register content.

Table. 4.6.5 - 334. Register content.

| Register             | Description                            |
|----------------------|--|
| Date and time        | dd.mm.yyyy hh:mm:ss.mss                |
| Event                | Event name                             |
| UL1, UL2, UL3 THDV   | Start/Alarm Voltage THD of each phase. |
| Setting group in use | Setting group 1...8 active.            |

## 4.6.6 Fault locator (21FL)

The fault locator function is used for recording an estimated distance to the point where a fault has occurred. It is mostly used in directional overcurrent protection or distance protection applications but can be also triggered by other protections. The function can be used if all three phase currents and three phase voltages have been connected to the device. The triggering signals, the triggering current and "Reactance per km" must be set in the configuration.

### Measured input

Function block uses fundamental frequency component of current and voltage measurements to calculate phase-to-phase or phase-to-ground loop impedances.

Table. 4.6.6 - 335. Measurement inputs of the 21FL function.

| Signal              | Description  |
|---------------------|--|
| I <sub>L1</sub> RMS | Fundamental frequency component of phase L1 (A) current measurement      |
| I <sub>L2</sub> RMS | Fundamental frequency component of phase L2 (B) current measurement      |
| I <sub>L3</sub> RMS | Fundamental frequency component of phase L3 (C) current measurement      |
| U <sub>1</sub> RMS  | Fundamental frequency component of U <sub>1</sub> /V voltage measurement |
| U <sub>2</sub> RMS  | Fundamental frequency component of U <sub>2</sub> /V voltage measurement |
| U <sub>3</sub> RMS  | Fundamental frequency component of U <sub>3</sub> /V voltage measurement |
| U <sub>4</sub> RMS  | Fundamental frequency component of U <sub>4</sub> /V voltage measurement |

### Fault locator triggering

The "Trig fault locator" input defines which signal triggers the fault locator. This can be any binary signal generated by the unit. Typically, a TRIP signal of a protection function or the "Open" status of the breaker is used as the triggering input.

Several conditions have to be met before the fault locator can trigger and record the distance to a fault. First, when receiving a triggering signal, the function checks if the calculation is blocked. The calculation blocking signals are determined by the "Block calculation" matrix set by the user. Next, the function checks if any phase-to-earth voltages are available. If there are no available voltages, the function can only record phase-to-phase impedance loops. If there are available voltages, the function can also record phase-to-neutral impedance loops. Depending on the measured phase currents at the moment the triggering signal was received, the recorded impedance loop is selected from the available options. See the table "Required current conditions" for more information on which conditions have to be met to trigger impedance recording.

Setting group selection controls the operating characteristics of the function, i.e. the user or user-defined logic can change function parameters while the function is running.

Table. 4.6.6 - 336. Pick-up settings.

| Name             | Range                     | Step               | Default          | Description   |
|------------------|---------------------------|--------------------|------------------|---|
| Trigger current> | 0.0...40.0×I <sub>n</sub> | 0.1×I <sub>n</sub> | 1×I <sub>n</sub> | Sets the trigger current. Affects which impedance loop is recorded, if anything is recorded at all (see the table below). |
| Reactance per km | 0.000...5.000Ω/km         | 0.001Ω/km          | 0.125Ω/km        | This setting is used for calculating the distance to a fault. Primary ohm value.  |

Table. 4.6.6 - 337. Required current conditions.

| Currents over limit                                 | P-E voltages available | P-E voltages not available |
|---|------------------------|----------------------------|
| Recorded impedance                                  |                        |                            |
| I <sub>L1</sub> , I <sub>L2</sub> , I <sub>L3</sub> | X <sub>L12</sub>       | X <sub>L12</sub>           |
| I <sub>L1</sub> , I <sub>L2</sub>                   | X <sub>L12</sub>       | X <sub>L12</sub>           |

| Currents over limit               | P-E voltages available | P-E voltages not available |
|-----------------------------------|------------------------|----------------------------|
| I <sub>L2</sub> , I <sub>L3</sub> | X <sub>L23</sub>       | X <sub>L23</sub>           |
| I <sub>L1</sub> , I <sub>L3</sub> | X <sub>L31</sub>       | X <sub>L31</sub>           |
| I <sub>L1</sub>                   | X <sub>L1</sub>        | No trigger                 |
| I <sub>L2</sub>                   | X <sub>L2</sub>        | No trigger                 |
| I <sub>L3</sub>                   | X <sub>L3</sub>        | No trigger                 |

If no current measurement requirements are fulfilled when the function receives a triggering signal, the function will not record impedance at all.

### Function blocking

The block signal is checked in the beginning of each program cycle. The blocking signal is received from the blocking matrix in the function's dedicated input. If the blocking signal is active when the pick-up element activates, a BLOCKED signal is generated and the function does not process the situation further.

The variables the user can set are binary signals from the system. The blocking signal needs to reach the device minimum of 5 ms before the set operating delay has passed in order for the blocking to activate in time.

### Events

The fault locator function (abbreviated "FLX" in event block names) generates events and registers from the status changes in the events listed below. The user can select which event messages are stored in the main event buffer: ON, OFF, or both. The events triggered by the function are recorded with a time stamp. The function also provides a resettable cumulative counter for the fault locator triggering events.

Table. 4.6.6 - 338. Event messages.

| Event block name | Event names                 |
|------------------|-----------------------------|
| FLX1             | Flocator triggered ON/OFF   |
| FLX1             | Flocator Calculation ON/OFF |

The function registers its operation into the last twelve (12) time-stamped registers. The table below presents the structure of the function's register content.

Table. 4.6.6 - 339. Register content.

| Register      | Description             |
|---------------|-------------------------|
| Date and time | dd.mm.yyyy hh:mm:ss.mss |
| Event         | Event name              |

| Register             | Description   |
|----------------------|---|
| Fault type           | <ul style="list-style-type: none"> <li>• L1-L2</li> <li>• L2-L3</li> <li>• L3-L1</li> <li>• L1-N</li> <li>• L2-N</li> <li>• L3-N</li> <li>• L1-L2-L3</li> </ul> |
| Fault direction      | <ul style="list-style-type: none"> <li>• Not detected</li> <li>• Forward</li> <li>• Reverse</li> </ul>  |
| Fault reactance      | In ohms ( $\Omega$ )  |
| Fault current        | In per-unit value   |
| Fault current        | In primary value  |
| Fault distance       | In kilometers (km)  |
| Setting group in use | Setting group 1...8 active.   |

### 4.6.7 Measurement recorder

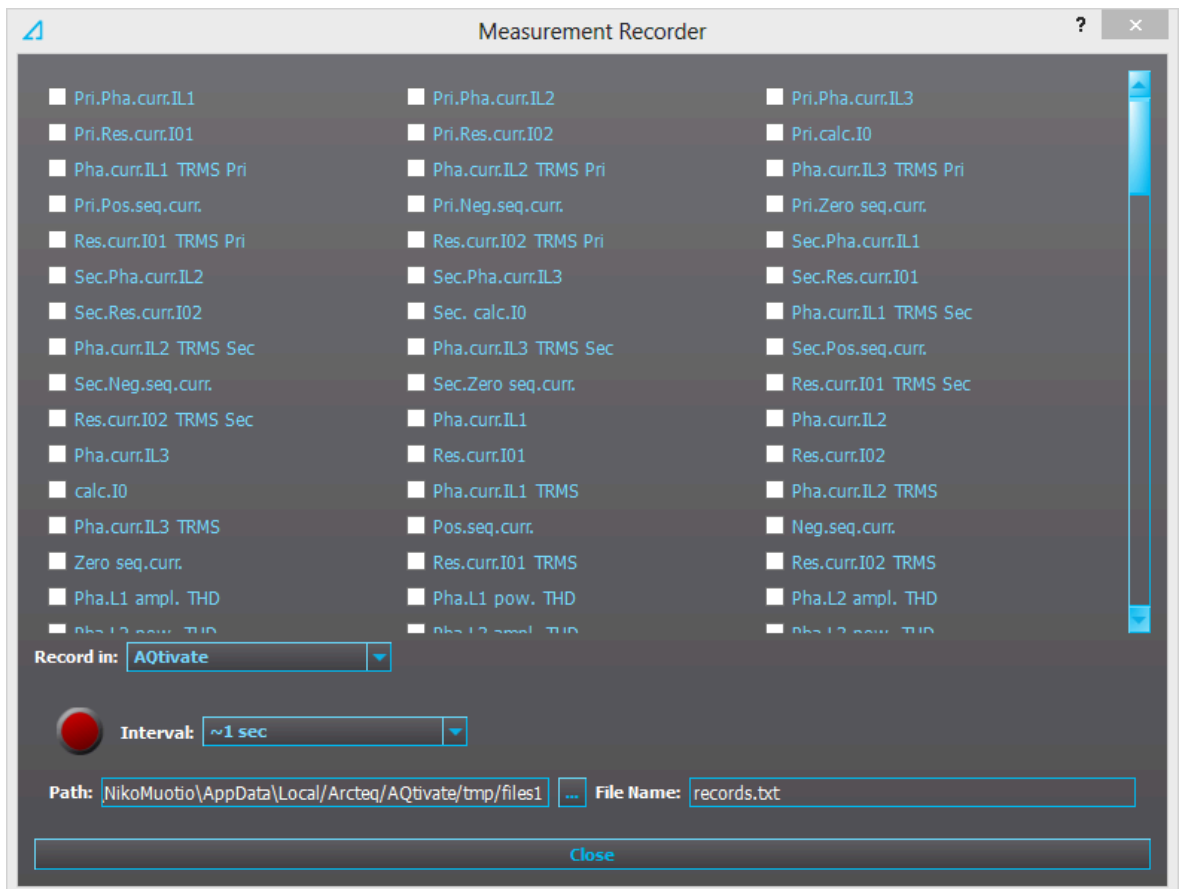

Measurements can be recorded to a file with the measurement recorder. The chosen measurements are recorded at selected intervals. In the "Measurement recorder" window, the measurements the user wants to be recorded can be selected by checking their respective check boxes. In order for the measurement recorder to activate, a connection to a device must be established via the setting tool software and its Live Edit mode must be enabled (see the setting tool manual for more information). Navigate to the measurement recorder through *Tools* → *Miscellaneous tools* → *Measurement recorder*. The recording interval can be changed from the "Interval" drop-down menu. From the "Record in" drop-down menu the user can also choose whether the measurements are recorded in the setting tool or in the device.

If the recording is done in the setting tool, both the setting tool software and its Live Edit mode have to be activated. The user can change the recording file location by editing the "Path" field. File names can also be changed with the "File name" field. Hitting the "Record" button (the big red circle) starts the recorder. Please note that closing the "Measurement recorder" window does not stop the recording; that can only be done by hitting the "Stop" button (the big blue circle).

If the recording is done in the device, only the recording interval needs to be set before recording can be started. The setting tool estimates the maximum recording time, which depends on the recording interval. When the measurement recorder is running, the measurements can be viewed in graph form with the AQtivate PRO software (see the image below).

Figure. 4.6.7 - 189. Measurement recorder values viewed with AQtivate PRO.



Table. 4.6.7 - 340. Available analog signals.

|                      |                |                                  |
|----------------------|----------------|----------------------------------|
| Current measurements | P-P Curr.l"L3  | L1 Imp.React.Ind.E.Mvarh         |
| Pri.Pha.Curr.IL1     | P-P Curr.l"01  | L1 Imp.React.Ind.E.kvarh         |
| Pri.Pha.Curr.IL2     | P-P Curr.l"02  | L1 Exp/Imp React.Ind.E.bal.Mvarh |
| Pri.Pha.Curr.IL3     | Pha.angle l"L1 | L1 Exp/Imp React.Ind.E.bal.kvarh |
| Pri.Res.Curr.I01     | Pha.angle l"L2 | L2 Exp.Active Energy MWh         |
| Pri.Res.Curr.I02     | Pha.angle l"L3 | L2 Exp.Active Energy kWh         |

|                       |                             |                                  |
|-----------------------|-----------------------------|----------------------------------|
| Pri.Calc.I0           | Res.Curr.angle I"01         | L2 Imp.Active Energy MWh         |
| Pha.Curr.IL1 TRMS Pri | Res.Curr.angle I"02         | L2 Imp.Active Energy kWh         |
| Pha.Curr.IL2 TRMS Pri | Calc.I"0.angle              | L2 Exp/Imp Act. E balance MWh    |
| Pha.Curr.IL3 TRMS Pri | I" Pos.Seq.Curr.angle       | L2 Exp/Imp Act. E balance kWh    |
| Pri.Pos.Seq.Curr.     | I" Neg.Seq.Curr.angle       | L2 Exp.React.Cap.E.Mvarh         |
| Pri.Neg.Seq.Curr.     | I" Zero.Seq.Curr.angle      | L2 Exp.React.Cap.E.kvarh         |
| Pri.Zero.Seq.Curr.    | <b>Voltage measurements</b> | L2 Imp.React.Cap.E.Mvarh         |
| Res.Curr.I01 TRMS Pri | U1Volt Pri                  | L2 Imp.React.Cap.E.kvarh         |
| Res.Curr.I02 TRMS Pri | U2Volt Pri                  | L2 Exp/Imp React.Cap.E.bal.Mvarh |
| Sec.Pha.Curr.IL1      | U3Volt Pri                  | L2 Exp/Imp React.Cap.E.bal.kvarh |
| Sec.Pha.Curr.IL2      | U4Volt Pri                  | L2 Exp.React.Ind.E.Mvarh         |
| Sec.Pha.Curr.IL3      | U1Volt Pri TRMS             | L2 Exp.React.Ind.E.kvarh         |
| Sec.Res.Curr.I01      | U2Volt Pri TRMS             | L2 Imp.React.Ind.E.Mvarh         |
| Sec.Res.Curr.I02      | U3Volt Pri TRMS             | L2 Imp.React.Ind.E.kvarh         |
| Sec.Calc.I0           | U4Volt Pri TRMS             | L2 Exp/Imp React.Ind.E.bal.Mvarh |
| Pha.Curr.IL1 TRMS Sec | Pos.Seq.Volt.Pri            | L2 Exp/Imp React.Ind.E.bal.kvarh |
| Pha.Curr.IL2 TRMS Sec | Neg.Seq.Volt.Pri            | L3 Exp.Active Energy MWh         |
| Pha.Curr.IL3 TRMS Sec | Zero.Seq.Volt.Pri           | L3 Exp.Active Energy kWh         |
| Sec.Pos.Seq.Curr.     | U1Volt Sec                  | L3 Imp.Active Energy MWh         |
| Sec.Neg.Seq.Curr.     | U2Volt Sec                  | L3 Imp.Active Energy kWh         |
| Sec.Zero.Seq.Curr.    | U3Volt Sec                  | L3 Exp/Imp Act. E balance MWh    |
| Res.Curr.I01 TRMS Sec | U4Volt Sec                  | L3 Exp/Imp Act. E balance kWh    |
| Res.Curr.I02 TRMS Sec | U1Volt Sec TRMS             | L3 Exp.React.Cap.E.Mvarh         |
| Pha.Curr.IL1          | U2Volt Sec TRMS             | L3 Exp.React.Cap.E.kvarh         |
| Pha.Curr.IL2          | U3Volt Sec TRMS             | L3 Imp.React.Cap.E.Mvarh         |
| Pha.Curr.IL3          | U4Volt Sec TRMS             | L3 Imp.React.Cap.E.kvarh         |
| Res.Curr.I01          | Pos.Seq.Volt.Sec            | L3 Exp/Imp React.Cap.E.bal.Mvarh |
| Res.Curr.I02          | Neg.Seq.Volt.Sec            | L3 Exp/Imp React.Cap.E.bal.kvarh |
| Calc.I0               | Zero.Seq.Volt.Sec           | L3 Exp.React.Ind.E.Mvarh         |
| Pha.Curr.IL1 TRMS     | U1Volt p.u.                 | L3 Exp.React.Ind.E.kvarh         |
| Pha.Curr.IL2 TRMS     | U2Volt p.u.                 | L3 Imp.React.Ind.E.Mvarh         |
| Pha.Curr.IL3 TRMS     | U3Volt p.u.                 | L3 Imp.React.Ind.E.kvarh         |

|                     |                           |                                  |
|---------------------|---------------------------|----------------------------------|
| Pos.Seq.Curr.       | U4Volt p.u.               | L3 Exp/Imp React.Ind.E.bal.Mvarh |
| Neg.Seq.Curr.       | U1Volt TRMS p.u.          | L3 Exp/Imp React.Ind.E.bal.kvarh |
| Zero.Seq.Curr.      | U2Volt TRMS p.u.          | Exp.Active Energy MWh            |
| Res.Curr.I01 TRMS   | U3Volt p.u.               | Exp.Active Energy kWh            |
| Res.Curr.I02 TRMS   | U4Volt p.u.               | Imp.Active Energy MWh            |
| Pha.L1 ampl. THD    | Pos.Seq.Volt. p.u.        | Imp.Active Energy kWh            |
| Pha.L2 ampl. THD    | Neg.Seq.Volt. p.u.        | Exp/Imp Act. E balance MWh       |
| Pha.L3 ampl. THD    | Zero.Seq.Volt. p.u.       | Exp/Imp Act. E balance kWh       |
| Pha.L1 pow. THD     | U1Volt Angle              | Exp.React.Cap.E.Mvarh            |
| Pha.L2 pow. THD     | U2Volt Angle              | Exp.React.Cap.E.kvarh            |
| Pha.L3 pow. THD     | U3Volt Angle              | Imp.React.Cap.E.Mvarh            |
| Res.I01 ampl. THD   | U4Volt Angle              | Imp.React.Cap.E.kvarh            |
| Res.I01 pow. THD    | Pos.Seq.Volt. Angle       | Exp/Imp React.Cap.E.bal.Mvarh    |
| Res.I02 ampl. THD   | Neg.Seq.Volt. Angle       | Exp/Imp React.Cap.E.bal.kvarh    |
| Res.I02 pow. THD    | Zero.Seq.Volt. Angle      | Exp.React.Ind.E.Mvarh            |
| P-P Curr.IL1        | System Volt UL12 mag      | Exp.React.Ind.E.kvarh            |
| P-P Curr.IL2        | System Volt UL12 mag (kV) | Imp.React.Ind.E.Mvarh            |
| P-P Curr.IL3        | System Volt UL23 mag      | Imp.React.Ind.E.kvarh            |
| P-P Curr.I01        | System Volt UL23 mag (kV) | Exp/Imp React.Ind.E.bal.Mvarh    |
| P-P Curr.I02        | System Volt UL31 mag      | Exp/Imp React.Ind.E.bal.kvarh    |
| Pha.angle IL1       | System Volt UL31 mag (kV) | <b>Other measurements</b>        |
| Pha.angle IL2       | System Volt UL1 mag       | TM> Trip expect mode             |
| Pha.angle IL3       | System Volt UL1 mag (kV)  | TM> Time to 100% T               |
| Res.Curr.angle I01  | System Volt UL2 mag       | TM> Reference T curr.            |
| Res.Curr.angle I02  | System Volt UL2 mag (kV)  | TM> Active meas curr.            |
| Calc.I0.angle       | System Volt UL3 mag       | TM> T est.with act. curr.        |
| Pos.Seq.Curr.angle  | System Volt UL3 mag (kV)  | TM> T at the moment              |
| Neg.Seq.Curr.angle  | System Volt U0 mag        | TM> Max.Temp.Rise All.           |
| Zero.Seq.Curr.angle | System Volt U0 mag (kV)   | TM> Temp.Rise atm.               |
| Pri.Pha.Curr.I"L1   | System Volt U1 mag        | TM> Hot Spot estimate            |
| Pri.Pha.Curr.I"L2   | System Volt U1 mag (kV)   | TM> Hot Spot Max. All            |
| Pri.Pha.Curr.I"L3   | System Volt U2 mag        | TM> Used k for amb.temp          |

|                        |                           |                          |
|------------------------|---------------------------|--------------------------|
| Pri.Res.Curr.I"01      | System Volt U2 mag (kV)   | TM> Trip delay remaining |
| Pri.Res.Curr.I"02      | System Volt U3 mag        | TM> Alarm 1 time to rel. |
| Pri.Calc.I"0           | System Volt U3 mag (kV)   | TM> Alarm 2 time to rel. |
| Pha.Curr.I"L1 TRMS Pri | System Volt U4 mag        | TM> Inhibit time to rel. |
| Pha.Curr.I"L2 TRMS Pri | System Volt U4 mag (kV)   | TM> Trip time to rel.    |
| Pha.Curr.I"L3 TRMS Pri | System Volt UL12 ang      | S1 Measurement           |
| I" Pri.Pos.Seq.Curr.   | System Volt UL23 ang      | S2 Measurement           |
| I" Pri.Neg.Seq.Curr.   | System Volt UL31 ang      | S3 Measurement           |
| I" Pri.Zero.Seq.Curr.  | System Volt UL1 ang       | S4 Measurement           |
| Res.Curr.I"01 TRMS Pri | System Volt UL2 ang       | S5 Measurement           |
| Res.Curr.I"02 TRMS Pri | System Volt UL3 ang       | S6 Measurement           |
| Sec.Pha.Curr.I"L1      | System Volt U0 ang        | S7 Measurement           |
| Sec.Pha.Curr.I"L2      | System Volt U1 ang        | S8 Measurement           |
| Sec.Pha.Curr.I"L3      | System Volt U2 ang        | S9 Measurement           |
| Sec.Res.Curr.I"01      | System Volt U3 ang        | S10 Measurement          |
| Sec.Res.Curr.I"02      | System Volt U4 ang        | S11 Measurement          |
| Sec.Calc.I"0           | <b>Power measurements</b> | S12 Measurement          |
| Pha.Curr.I"L1 TRMS Sec | L1 Apparent Power (S)     | Sys.meas.frqs            |
| Pha.Curr.I"L2 TRMS Sec | L1 Active Power (P)       | f atm.                   |
| Pha.Curr.I"L3 TRMS Sec | L1 Reactive Power (Q)     | f meas from              |
| I" Sec.Pos.Seq.Curr.   | L1 Tan(phi)               | SS1.meas.frqs            |
| I" Sec.Neg.Seq.Curr.   | L1 Cos(phi)               | SS1f meas from           |
| I" Sec.Zero.Seq.Curr.  | L2 Apparent Power (S)     | SS2 meas.frqs            |
| Res.Curr.I"01 TRMS Sec | L2 Active Power (P)       | SS2f meas from           |
| Res.Curr.I"02 TRMS Sec | L2 Reactive Power (Q)     | L1 Bias current          |
| Pha.Curr.I"L1          | L2 Tan(phi)               | L1 Diff current          |
| Pha.Curr.I"L2          | L2 Cos(phi)               | L1 Char current          |
| Pha.Curr.I"L3          | L3 Apparent Power (S)     | L2 Bias current          |
| Res.Curr.I"01          | L3 Active Power (P)       | L2 Diff current          |
| Res.Curr.I"02          | L3 Reactive Power (Q)     | L2 Char current          |
| Calc.I"0               | L3 Tan(phi)               | L3 Bias current          |
| Pha.Curr.I"L1 TRMS     | L3 Cos(phi)               | L3 Diff current          |

|                     |                                  |                      |
|---------------------|----------------------------------|----------------------|
| Pha.Curr.I" L2 TRMS | 3PH Apparent Power (S)           | L3 Char current      |
| Pha.Curr.I" L3 TRMS | 3PH Active Power (P)             | HV I0d> Bias current |
| I" Pos.Seq.Curr.    | 3PH Reactive Power (Q)           | HV I0d> Diff current |
| I" Neg.Seq.Curr.    | 3PH Tan(phi)                     | HV I0d> Char current |
| I" Zero.Seq.Curr.   | 3PH Cos(phi)                     | LV I0d> Bias current |
| Res.Curr.I"01 TRMS  | <b>Energy measurements</b>       | LV I0d> Diff current |
| Res.Curr.I"02 TRMS  | L1 Exp.Active Energy MWh         | LV I0d> Char current |
| Pha.IL"1 ampl. THD  | L1 Exp.Active Energy kWh         | Curve1 Input         |
| Pha.IL"2 ampl. THD  | L1 Imp.Active Energy MWh         | Curve1 Output        |
| Pha.IL"3 ampl. THD  | L1 Imp.Active Energy kWh         | Curve2 Input         |
| Pha.IL"1 pow. THD   | L1 Exp/Imp Act. E balance MWh    | Curve2 Output        |
| Pha.IL"2 pow. THD   | L1 Exp/Imp Act. E balance kWh    | Curve3 Input         |
| Pha.IL"3 pow. THD   | L1 Exp.React.Cap.E.Mvarh         | Curve3 Output        |
| Res.I"01 ampl. THD  | L1 Exp.React.Cap.E.kvarh         | Curve4 Input         |
| Res.I"01 pow. THD   | L1 Imp.React.Cap.E.Mvarh         | Curve4 Output        |
| Res.I"02 ampl. THD  | L1 Imp.React.Cap.E.kvarh         | Control mode         |
| Res.I"02 pow. THD   | L1 Exp/Imp React.Cap.E.bal.Mvarh | Motor status         |
| P-P Curr.I" L1      | L1 Exp/Imp React.Cap.E.bal.kvarh | Active setting group |
| P-P Curr.I" L2      | L1 Exp.React.Ind.E.Mvarh         |                      |
|                     | L1 Exp.React.Ind.E.kvarh         |                      |

## 4.6.8 Fault register

The fault register function records the value of the selected magnitudes at the time of a pre-defined trigger signal. A typical application is the recording of fault currents or voltages at the time of the breaker trips; it can also be used to record the values from any trigger signal set by the user. The user can select whether the function records per-unit values or primary values. Additionally, the user can set the function to record overcurrent fault types or voltage fault types. The function operates instantly from the trigger signal.

The fault register function has an integrated fault display which shows the current fault values when the tripped by one of the following functions:

- I> (non-directional overcurrent)
- I2> (current unbalance)
- Idir> (directional overcurrent)
- I0> (non-directional earth fault)
- I0dir> (directional earth fault)
- f<(underfrequency)
- f> (overfrequency)
- U< (undervoltage)

- U> (overvoltage)
- U1/U2 >/< (sequence voltage)
- U0> (residual voltage)
- P> (over power)
- P< (under power)
- Prev> (reverse power)
- T> (thermal overload)

Figure. 4.6.8 - 190. 12 latest recordings can be accessed from HMI if "VrecRegisters" view has been enabled in "Carousel designer" tool.

|           |                         |       |  |
|-----------|-------------------------|-------|--|
| I>Trip    | 10/02/2025 08:12:09.580 | A-B-C |  |
| I>Trip    | 10/02/2025 08:11:18.084 | B-C   |  |
| I>Trip    | 10/02/2025 08:11:04.012 | B-C   |  |
| I>Trip    | 10/02/2025 08:10:44.619 | B-C   | I>Trip<br>10/02/2025 08:12:09.580<br>A-B-C |
| I>>>Trip  | 10/02/2025 08:03:38.431 | -     | SG1  |
| I>>>Trip  | 10/02/2025 08:02:50.259 | -     | Mag 1 :0.00                                |
| I>>Trip   | 10/02/2025 08:02:39.069 | -     | Mag 2 :0.00                                |
| I>>>>Trip | 10/02/2025 08:02:28.479 | -     | Mag 3 :0.00                                |
| I>Trip    | 10/02/2025 08:02:20.968 | -     | Mag 4 :0.00                                |
|           |                         |       | Mag 5 :0.00                                |
|           |                         |       | Mag 6 :0.00                                |
|           |                         |       | Mag 7 :0.00                                |
|           |                         |       | Mag 8 :0.00                                |
| -         | -                       | -     |  |
| -         | -                       | -     |  |
| -         | -                       | -     |  |

### Measured input

The function block uses analog current and voltage measurement values. Based on these values, the device calculates the primary and secondary values of currents, voltages, powers, and impedances as well as other values.

The user can set up to eight (8) magnitudes to be recorded when the function is triggered. An overcurrent fault type, a voltage fault type, and a tripped stage can be recorded and reported straight to SCADA.

**NOTICE!**

 The available measurement values depend on the device type. If only current analog measurements are available, the recorder can solely use signals which only use current. The same applies, if only voltage analog measurements are available.

Table. 4.6.8 - 341. Current based measurements available.

| Currents   | Description  |
|--|--|
| IL1 (ff), IL2 (ff), IL3 (ff), IO1 (ff), IO2 (ff) | The fundamental frequency current measurement values (RMS) of phase currents and of residual currents. |

|   |  |
|---|--|
| IL1TRMS, IL2TRMS, IL3TRMS, I01TRMS, I02TRMS   | The TRMS current measurement values of phase currents and of residual currents.  |
| IL1,2,3 & I01/I02 2 <sup>nd</sup> h., 3 <sup>rd</sup> h., 4 <sup>th</sup> h., 5 <sup>th</sup> h., 7 <sup>th</sup> h., 9 <sup>th</sup> h., 11 <sup>th</sup> h., 13 <sup>th</sup> h., 15 <sup>th</sup> h., 17 <sup>th</sup> h., 19 <sup>th</sup> h. | The magnitudes of phase current components: Fundamental, 2 <sup>nd</sup> harmonic, 3 <sup>rd</sup> harmonic, 4 <sup>th</sup> harmonic, 5 <sup>th</sup> harmonic 7 <sup>th</sup> , harmonic 9 <sup>th</sup> , harmonic 11 <sup>th</sup> , harmonic 13 <sup>th</sup> , harmonic 15 <sup>th</sup> , harmonic 17 <sup>th</sup> , harmonic 19 <sup>th</sup> harmonic current. |
| I1, I2, I0Z   | The positive sequence current, the negative sequence current and the zero sequence current.  |
| I0CalcMag   | The residual current calculated from phase currents.   |
| IL1Ang, IL2Ang, IL3Ang, I01Ang, I02Ang, I0CalcAng, I1Ang, I2Ang   | The angles of each measured current.   |

Table. 4.6.8 - 342. Voltage based measurements available.

| Voltages  | Description   |
|---|---|
| UL1Mag, UL2Mag, UL3Mag, UL12Mag, UL23Mag, UL31Mag<br>U0Mag, U0CalcMag | The magnitudes of phase voltages, of phase-to-phase voltages, and of residual voltages. |
| U1 Pos.seq V mag, U2 Neg.seq V mag                                    | The positive sequence voltage and the negative sequence voltage.                        |
| UL1Ang, UL2Ang, UL3Ang, UL12Ang, UL23Ang, UL31Ang<br>U0Ang, U0CalcAng | The angles of phase voltages, of phase-to-phase voltages, and of residual voltages.     |
| U1 Pos.seq V Ang, U2 Neg.seq V Ang                                    | The positive sequence angle and the negative sequence angle.                            |

Table. 4.6.8 - 343. Power based measurements available.

| Powers                                      | Description  |
|---|--|
| S3PH, P3PH, Q3PH                            | The three-phase apparent, active and reactive powers.      |
| SL1, SL2, SL3, PL1, PL2, PL3, QL1, QL2, QL3 | The phase apparent, active and reactive powers.            |
| tanfi3PH, tanfiL1, tanfiL2, tanfiL3         | The tan ( $\phi$ ) of three-phase powers and phase powers. |
| cosfi3PH, cosfiL1, cosfiL2, cosfiL3         | The cos ( $\phi$ ) of three-phase powers and phase powers. |

Table. 4.6.8 - 344. Impedance and admittance based measurements available.

| Impedances and admittances  | Description   |
|---|---|
| RL12, RL23, RL31<br>XL12, XL23, XL31,<br>RL1, RL2, RL3<br>XL1, XL2, XL3<br>Z12, Z23, Z31<br>ZL1, ZL2, ZL3 | The phase-to-phase and phase-to-neutral resistances, reactances and impedances. |

|   |  |
|---|--|
| Z12Ang, Z23Ang, Z31Ang,<br>ZL1Ang, ZL2Ang, ZL3Ang           | The phase-to-phase and phase-to-neutral impedance angles.                    |
| Rseq, Xseq, Zseq<br>RseqAng, XseqAng,<br>ZseqAng            | The positive sequence resistance, reactance and impedance values and angles. |
| GL1, GL2, GL3, G0<br>BL1, BL2, BL3, B0<br>YL1, YL2, YL3, Y0 | The conductances, susceptances and admittances.                              |
| YL1angle, YL2angle,<br>YL3angle<br>Y0angle                  | The admittance angles.   |

Table. 4.6.8 - 345. Other measurements available.

| Others             | Description  |
|--------------------|--|
| System f.          | The tracking frequency in use at that moment.              |
| Ref f1             | The reference frequency 1.                                 |
| Ref f2             | The reference frequency 2.                                 |
| M thermal T        | The motor thermal temperature.                             |
| F thermal T        | The feeder thermal temperature.                            |
| T thermal T        | The transformer thermal temperature.                       |
| RTD meas 1...16    | The RTD measurement channels 1...16.                       |
| Ext RTD meas 1...8 | The external RTD measurement channels 1...8 (ADAM module). |

## Reported values

When triggered, the function holds the recorded values of up to eight channels, as set. In addition to this tripped stage, the overcurrent fault type and the voltage fault types are reported to SCADA.

Table. 4.6.8 - 346. Reported values.

| Name                   | Range  | Description                 |
|------------------------|--|-----------------------------|
| Tripped stage          | <ul style="list-style-type: none"> <li>• -</li> <li>• I&gt; Trip</li> <li>• I&gt;&gt; Trip</li> <li>• I&gt;&gt;&gt; Trip</li> <li>• I&gt;&gt;&gt;&gt; Trip</li> <li>• IDir&gt; Trip</li> <li>• IDir&gt;&gt; Trip</li> <li>• IDir&gt;&gt;&gt; Trip</li> <li>• IDir&gt;&gt;&gt;&gt; Trip</li> <li>• U&gt; Trip</li> <li>• U&gt;&gt; Trip</li> <li>• U&gt;&gt;&gt; Trip</li> <li>• U&gt;&gt;&gt;&gt; Trip</li> <li>• U&lt; Trip</li> <li>• U&lt;&lt; Trip</li> <li>• U&lt;&lt;&lt; Trip</li> <li>• U&lt;&lt;&lt;&lt; Trip</li> <li>• IO&gt; TRIP</li> <li>• IO&gt;&gt; Trip</li> <li>• IO&gt;&gt;&gt; Trip</li> <li>• IO&gt;&gt;&gt;&gt; Trip</li> <li>• IODir&gt; Trip</li> <li>• IODir&gt;&gt; Trip</li> <li>• IODir&gt;&gt;&gt; Trip</li> <li>• IODir&gt;&gt;&gt;&gt; Trip</li> <li>• f&gt; Trip</li> <li>• f&gt;&gt; Trip</li> <li>• f&gt;&gt;&gt; Trip</li> <li>• f&gt;&gt;&gt;&gt; Trip</li> <li>• f&lt; Trip</li> <li>• f&lt;&lt; Trip</li> <li>• f&lt;&lt;&lt; Trip</li> <li>• f&lt;&lt;&lt;&lt; Trip</li> <li>• P&gt; Trip</li> <li>• P&lt; Trip</li> <li>• Prev&gt; Trip</li> <li>• T&gt; Trip</li> <li>• I2&gt; Trip</li> <li>• I2&gt;&gt; Trip</li> <li>• I2&gt;&gt;&gt; Trip</li> <li>• I2&gt;&gt;&gt;&gt; Trip</li> <li>• U1/2 &gt; Trip</li> <li>• U1/2 &gt;&gt; Trip</li> <li>• U1/2 &gt;&gt;&gt; Trip</li> <li>• U1/2 &gt;&gt;&gt;&gt; Trip</li> <li>• U0&gt; Trip</li> <li>• U0&gt;&gt; Trip</li> <li>• U0&gt;&gt;&gt; Trip</li> <li>• U0&gt;&gt;&gt;&gt; Trip</li> </ul> | The tripped stage.          |
| Overcurrent fault type | <ul style="list-style-type: none"> <li>• A-G</li> <li>• B-G</li> <li>• A-B</li> <li>• C-G</li> <li>• A-C</li> <li>• B-C</li> <li>• A-B-C</li> </ul>  | The overcurrent fault type. |

| Name               | Range   | Description                                      |
|--------------------|---|--|
| Voltage fault type | <ul style="list-style-type: none"> <li>• A(AB)</li> <li>• B(BC)</li> <li>• A-B(AB-BC)</li> <li>• C(CA)</li> <li>• A-C(AB-CA)</li> <li>• B-C(BC-CA)</li> <li>• A-B-C</li> <li>• Overfrequency</li> <li>• Underfrequency</li> <li>• Overpower</li> <li>• Underpower</li> <li>• Reversepower</li> <li>• Thermal overload</li> <li>• Unbalance</li> <li>• Harmonic overcurrent</li> <li>• Residual overvoltage</li> </ul> | The voltage fault type.                          |
| Magnitude 1...8    | 0.000...1800.000 A/V/p.u.   | The recorded value in one of the eight channels. |

## Events

The fault register function (abbreviated "VREC" in event block names) generates events from the status changes in the events listed below. The user can select which event messages are stored in the main event buffer: ON, OFF, or both. The events triggered by the function are recorded with a time stamp.

Table. 4.6.8 - 347. Event messages.

| Event block name | Event name                |
|------------------|---------------------------|
| VREC1            | Recorder triggered ON/OFF |

## 4.6.9 Event logger

Event logger records status changes of protection functions, digital inputs, logical signals etc. Events are recorded with a timestamp. The time stamp resolution is 1 ms. Up to 15 000 events can be stored at once. When 15 000 events have been recorded, the event history will begin to remove the oldest events to make room for new events. You can find more information about event masks in the selected function's "Events" tab. Event masks determine what is recorded into the event history; they are configured in each function's individual settings in the *Protection*, *Control* and *Monitoring* menu. Event history is accessible with PC setting tool (*Tools* → *Events and Logs* → *Event history*) and from the device HMI if "Events" view has been configured with Carousel designer in PC setting tool.

### Event overload detection

Continuous generation of a high number of nuisance events may have adverse effects on the operation and communication capabilities of the device. A high number of nuisance events may end up being generated due to mistakes in configuration and/or installation. For example, mistakes in logic configuration or RTD sensor wiring, in conjunction with suitable event mask settings may generate an excessive number of unintended events. Event overload detector looks for a condition where over 200 events are being generated inside one (1) second window (more than 1 event every 5 milliseconds on average). If such a condition is detected, further events are blocked and an IRF (Internal Relay Fault-message) is issued. The event blocking is released and the IRF can be cleared after 5 seconds if the overload condition has been corrected. Other device operations, such as protection and communication, remain available even during the event overload condition.

## 4.6.10 Disturbance recorder (DR)

The disturbance recorder is a high-capacity (64 MB permanent flash memory) and fully digital recorder integrated to the protection relay. The maximum sample rate of the recorder's analog channels is 64 samples per cycle. Up to 20 analog recording channels and 96 digital channels are supported. Maximum capacity of recordings is 100.

The recorder provides an effective tool to analyze the performance of the power system during network disturbance situations. The recorder's output is in general COMTRADE format and it is compatible with most recording viewers and injection devices. The files are based on the IEEE standard C37.111-1999. Captured recordings can be injected as playback with secondary testing tools that support the COMTRADE file format. Playback of files might help to analyze the fault, or can be simply used for educational purposes.

### Analog and digital recording channels

Table. 4.6.10 - 348. Analog recording channels.

| Signal      | Description  |
|-------------|--|
| IL1         | Phase current $I_{L1}$   |
| IL2         | Phase current $I_{L2}$   |
| IL3         | Phase current $I_{L3}$   |
| I01c        | Residual current $I_{01}$ coarse*  |
| I01f        | Residual current $I_{01}$ fine*  |
| I02c        | Residual current $I_{02}$ coarse*  |
| I02f        | Residual current $I_{02}$ fine*  |
| IL1"        | Phase current $I_{L1}$ (CT card 2)                                       |
| IL2"        | Phase current $I_{L2}$ (CT card 2)                                       |
| IL3"        | Phase current $I_{L3}$ (CT card 2)                                       |
| I01"c       | Residual current $I_{01}$ coarse* (CT card 2)                            |
| I01"f       | Residual current $I_{01}$ fine* (CT card 2)                              |
| I02"c       | Residual current $I_{02}$ coarse* (CT card 2)                            |
| I02"f       | Residual current $I_{02}$ fine* (CT card 2)                              |
| U1(2)VT1    | Line-to-neutral $U_{L1}$ or line-to-line voltage $U_{L12}$ (VT card 1)   |
| U2(3)VT1    | Line-to-neutral $U_{L2}$ or line-to-line voltage $U_{L23}$ (VT card 1)   |
| U3(1)VT1    | Line-to-neutral $U_{L3}$ or line-to-line voltage $U_{L31}$ (VT card 1)   |
| U0(ss)VT1   | Zero sequence voltage $U_0$ or synchrocheck voltage $U_{SS}$ (VT card 1) |
| F tracked 1 | Tracked frequency of reference 1   |
| F tracked 2 | Tracked frequency of reference 2   |

| Signal      | Description  |
|-------------|--|
| F tracked 3 | Tracked frequency of reference 3   |
| ISup        | Current measurement module voltage supply supervision (CT card 1)        |
| ISup"       | Current measurement module voltage supply supervision (CT card 2)        |
| USup        | Voltage measurement module voltage supply supervision (VT card 1)        |
| IL1""       | Phase current $I_{L1}$ (CT card 3)                                       |
| IL2""       | Phase current $I_{L2}$ (CT card 3)                                       |
| IL3""       | Phase current $I_{L3}$ (CT card 3)                                       |
| I01""c      | Residual current $I_{01}$ coarse* (CT card 3)                            |
| I01""f      | Residual current $I_{01}$ fine* (CT card 3)                              |
| I02""c      | Residual current $I_{02}$ coarse* (CT card 3)                            |
| I02""f      | Residual current $I_{02}$ fine* (CT card 3)                              |
| ISup_3      | Current measurement module voltage supply supervision (CT card 3)        |
| UL1(2)VT2   | Line-to-neutral $U_{L1}$ or line-to-line voltage $U_{L12}$ (VT card 2)   |
| UL2(3)VT2   | Line-to-neutral $U_{L2}$ or line-to-line voltage $U_{L23}$ (VT card 2)   |
| UL3(1)VT2   | Line-to-neutral $U_{L3}$ or line-to-line voltage $U_{L31}$ (VT card 2)   |
| U0(SS)VT2   | Zero sequence voltage $U_0$ or synchrocheck voltage $U_{ss}$ (VT card 2) |
| USup_2      | Voltage measurement module voltage supply supervision (VT card 2)        |

**\*NOTE:** There are two signals for each residual current channel in the disturbance recorder: coarse and fine. A coarse signal is capable of sampling in the full range of the current channel but suffers a loss of accuracy at very low currents. A fine signal is capable of sampling at very low currents and with high accuracy but cuts off at higher currents. Table below lists performance of both channels with fine and coarse gain.

Table. 4.6.10 - 349. Residual current channel performance with coarse or residual gain.

| Channel | Coarse gain range | Fine gain range | Fine gain peak |
|---------|-------------------|-----------------|----------------|
| I01     | 0...150 A         | 0...10 A        | 15 A           |
| I02     | 0...75 A          | 0...5 A         | 8 A            |

## Recording settings and triggering

Disturbance recorder can be triggered manually or automatically by using the dedicated triggers. Every signal listed in "Digital recording channels" can be selected to trigger the recorder.

The number of analog and digital channels together with the sample rate and the time setting affect the recording size. See calculation examples below in the section titled "Estimating the maximum length of total recording time". The recording size affects how many recordings can be stored at a time, but the number can't exceed 100 recordings.

Table. 4.6.10 - 350. Recorder control settings.

| Name                             | Range  | Description  |
|----------------------------------|--|--|
| Recorder enabled                 | <ul style="list-style-type: none"> <li>Enabled</li> <li>Disabled</li> </ul>  | Enables and disables the disturbance recorder function.  |
| Recorder status                  | <ul style="list-style-type: none"> <li>Recorder ready</li> <li>Recording triggered</li> <li>Recording and storing</li> <li>Storing recording</li> <li>Recorder full</li> <li>Wrong config</li> </ul> | <p>Indicates the status of recorder.</p> <p>"Wrong config" is activated if:</p> <ul style="list-style-type: none"> <li>"Pre-triggering time" is longer than "Max length of recording" setting</li> <li>"Max amount of recordings" is "1" and "Recording mode" is "FIFO".</li> <li>"1ms" digital channel sample rate is selected when analog channel sample rate is 8 or 16 s/c.</li> </ul> |
| Clear record                     | 0...2 <sup>32</sup> -1   | Clears selected recording. If "1" is inserted, first recording will be cleared from memory. If "10" is inserted, tenth (10th) recording will be cleared from memory.   |
| Manual trigger                   | <ul style="list-style-type: none"> <li>-</li> <li>Trig</li> </ul>  | Triggers disturbance recording manually. This parameter will return back to "-" automatically.   |
| Clear all records                | <ul style="list-style-type: none"> <li>-</li> <li>Clear</li> </ul>   | Clears all disturbance recordings.   |
| Clear newest record              | <ul style="list-style-type: none"> <li>-</li> <li>Clear</li> </ul>   | Clears the newest stored disturbance recording.  |
| Clear oldest record              | <ul style="list-style-type: none"> <li>-</li> <li>Clear</li> </ul>   | Clears the oldest stored disturbance recording.  |
| Max. number of recordings        | 0...100  | Displays the maximum number of recordings that can be stored in the device's memory with settings currently in use. The maximum number of recordings can go up to 100.   |
| Max. length of a recording       | 0.000...1800.000s  | Displays the maximum length of a single recording.   |
| Max. location of the pre-trigger | 0.000...1800.000s  | Displays the highest pre-triggering time that can be set with the settings currently in use.   |
| Recordings in memory             | 0...100  | Displays how many recordings are stored in the memory.   |

Table. 4.6.10 - 351. Recorder trigger setting.

| Name             | Description  |
|------------------|--|
| Recorder trigger | Selects the trigger input(s). Clicking the "Edit" button brings up a pop-up window, and checking the boxes enable the selected triggers. |

Table. 4.6.10 - 352. Recorder settings.

| Name                         | Range   | Default  | Description   |
|------------------------------|---|----------|---|
| Recording length             | 0.100...1800.000s   | 1s       | Sets the length of a recording.   |
| Recording mode               | <ul style="list-style-type: none"> <li>FIFO</li> <li>Keep olds</li> </ul>                           | FIFO     | Selects what happens when the memory is full. "FIFO" (= first in, first out) replaces the oldest stored recording with the latest one. "Keep olds" does not accept new recordings.  |
| Analog channel samples       | <ul style="list-style-type: none"> <li>64s/c</li> <li>32s/c</li> <li>16s/c</li> <li>8s/c</li> </ul> | 64s/c    | Selects the sample rate of the disturbance recorder in samples per cycle. The samples are saved from the measured wave according to this setting.   |
| Digital channel samples      | <ul style="list-style-type: none"> <li>5 ms</li> <li>1 ms</li> </ul>                                | 5 ms     | The fixed sample rate of the recorded digital channels. Recorded digital channels can be chosen with "Recorder digital channels" below.<br>NOTE: 1 ms sample rate can't be used when analog channel sample rate is 8 or 16 s/c.   |
| Pretriggering time           | 0.2...30.0s   | 0.2s     | Sets the recording length before the trigger.   |
| Analog recording CH1...CH20  | 0...8 freely selectable channels  | -        | Selects the analog channel for recording. Please see the list of all available analog channels in the section titled "Analog and digital recording channels".   |
| Automatically get recordings | <ul style="list-style-type: none"> <li>Disabled</li> <li>Enabled</li> </ul>                         | Disabled | Enables and disables the automatic transfer of recordings. The recordings are taken from the device's protection CPU and transferred to the device's FTP directory in the communication CPU; the FTP client then automatically loads the recordings from the device and transfers them further to the SCADA system. Please note that when this setting is enabled, all new disturbance recordings will be pushed to the FTP server of the device. Up to six (6) recordings can be stored in the FTP at once. Once those six recordings have been retrieved and removed, more recordings will then be pushed to the FTP. When a recording has been sent to the FTP server of the device, it is no longer accessible through setting tools <i>Disturbance recorder</i> → <i>Get DR files</i> command. |
| Recorder digital channels    | 0...96 freely selectable channels   | -        | Selects the digital channel for recording. Please see the list of all available digital channels in the section titled "Analog and digital recording channels".   |

**NOTICE!**

The disturbance recorder is not ready unless the "Max. length of a recording" parameter is showing some value other than zero. At least one trigger input has to be selected in the "Recorder Trigger" setting to fulfill this term.

**NOTICE!**

When writing new disturbance recorder settings to the device, any existing recordings in the device memory will be deleted.

## Estimating the maximum length of total recording time

Once the disturbance recorder's settings have been made and loaded to the device, the device automatically calculates and displays the total length of recordings. However, if the user wishes to confirm this calculation, they can do so with the following formula. Please note that the formula assumes there are no other files in the FTP that share the 64 MB space.

$$\frac{\text{Total sample reserve}}{(f_n * (Ch_{an} + 1) * SR) + (200 \text{ Hz} * Ch_{dig})}$$

Where:

- total sample reserve = the number of samples available in the FTP when no other files are saved; calculated by dividing the total number of available bytes by 4 bytes (=the size of one sample); e.g. 64 306 588 bytes/4 bytes = 16 076 647 samples.
- $f_n$  = the nominal frequency (Hz).
- $Ch_{an}$  = the number of analog channels recorded; "+ 1" stands for the time stamp for each recorded sample.
- $SR$  = the selected sample rate (s/c).
- 200 Hz = the rate at which digital channels are always recorded, i.e. 5 ms.
- $Ch_{dig}$  = the number of digital channels recorded.

For example, let us say the nominal frequency is 50 Hz, the selected sample rate is 64 s/c, nine (9) analog channels and two (2) digital channels record. The calculation is as follows:

$$\frac{16\,076\,647 \text{ samples}}{(50 \text{ Hz} * (9 + 1) * 64) + (200 \text{ Hz} * 2)} \approx 496 \text{ s}$$

Therefore, the maximum recording length in our example is approximately 496 seconds.

## Application example

This chapter presents an application example of how to set the disturbance recorder and analyze its output. The recorder is configured by using the setting tool software or device HMI, and the results are analyzed with the AQviewer software (is automatically downloaded and installed with AQtivate). Registered users can download the latest tools from the Arcteq website ([arcteq.fi/downloads/](http://arcteq.fi/downloads/)).

In this example, we want the recordings to be made according to the following specifications:

- the recording length is 6.0 s
- the sample rate is 64 s/c (therefore, with a 50 Hz system frequency a sample is taken every 312.5  $\mu$ s)
- the analog channels 1...8 are used
- digital channels are tracked every 5 ms
- the first activation of the overcurrent stage trip ( $I > TRIP$ ) triggers the recorder
- the pre-triggering time is 5 (ie. how long is recorded before the  $I > TRIP$  signal) and the post-triggering time is 1 s

The image below shows how these settings are placed in the setting tool.

Figure. 4.6.10 - 191. Disturbance recorder settings.

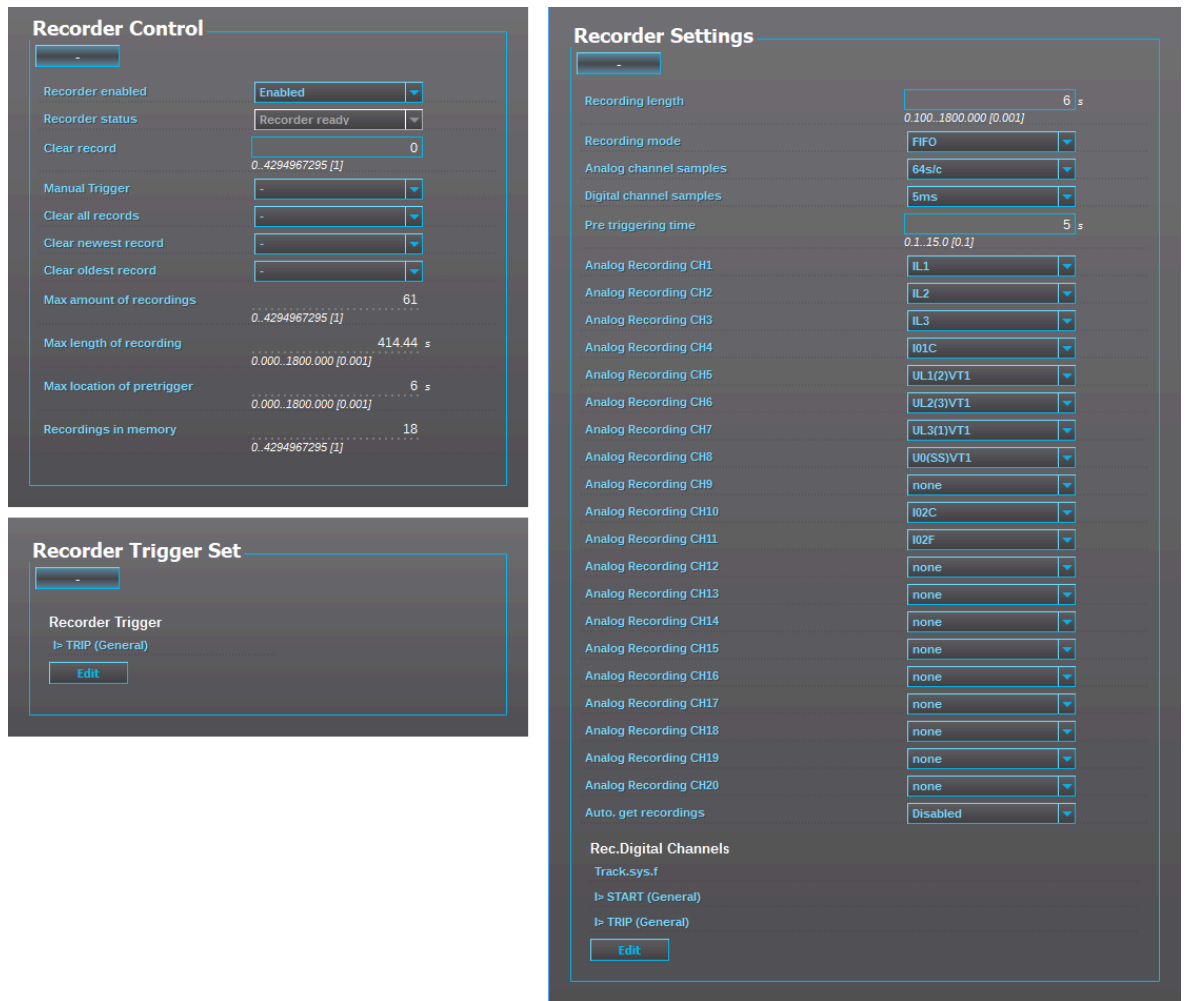
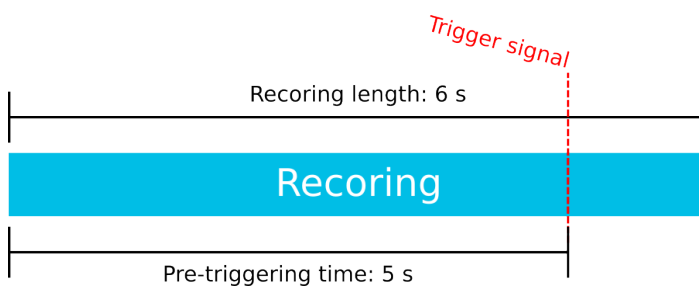
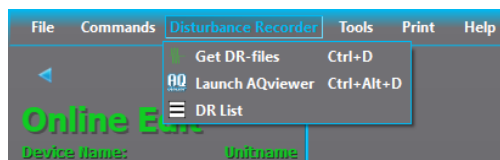

Figure. 4.6.10 - 192. Effects of recording length and pre-triggering time signals. This example is based on the settings shown above.



When there is at least one recording in the device's memory, that recording can be analyzed by using the AQviewer software (see the image below). However, the recording must first be made accessible to AQviewer. The user can read it from the device's memory (*Disturbance recorder* → *Get DR-files*). Alternatively, the user can load the recordings individually (*Disturbance recorder* → *DR List*) from a folder in the PC's hard disk drive; the exact location of the folder is described in *Tools* → *Settings* → *DR path*.



The user can also launch the AQviewer software from the *Disturbance recorder* menu. AQviewer software instructions can be found in AQtivate Instruction manual (<https://www.arcteq.com/documents-and-software/>).

## Events

The disturbance recorder function (abbreviated "DR" in event block names) generates events and registers from the status changes in the events listed below. Events cannot be masked off. The events triggered by the function are recorded with a time stamp.

Table. 4.6.10 - 353. Event messages.

| Event block name | Event names                 |
|------------------|-----------------------------|
| DR1              | Recorder triggered ON/OFF   |
| DR1              | Recorder memory cleared     |
| DR1              | Oldest record cleared       |
| DR1              | Recorder memory full ON/OFF |
| DR1              | Recording ON/OFF            |
| DR1              | Storing recording ON/OFF    |
| DR1              | Newest record cleared       |

### 4.6.11 User access control

As a factory default, no user level is locked with a password in a device. In order to activate the different user levels, push the **Lock** button on the device's front panel and set the desired passwords for the user levels.

Figure. 4.6.11 - 193. User access control view.

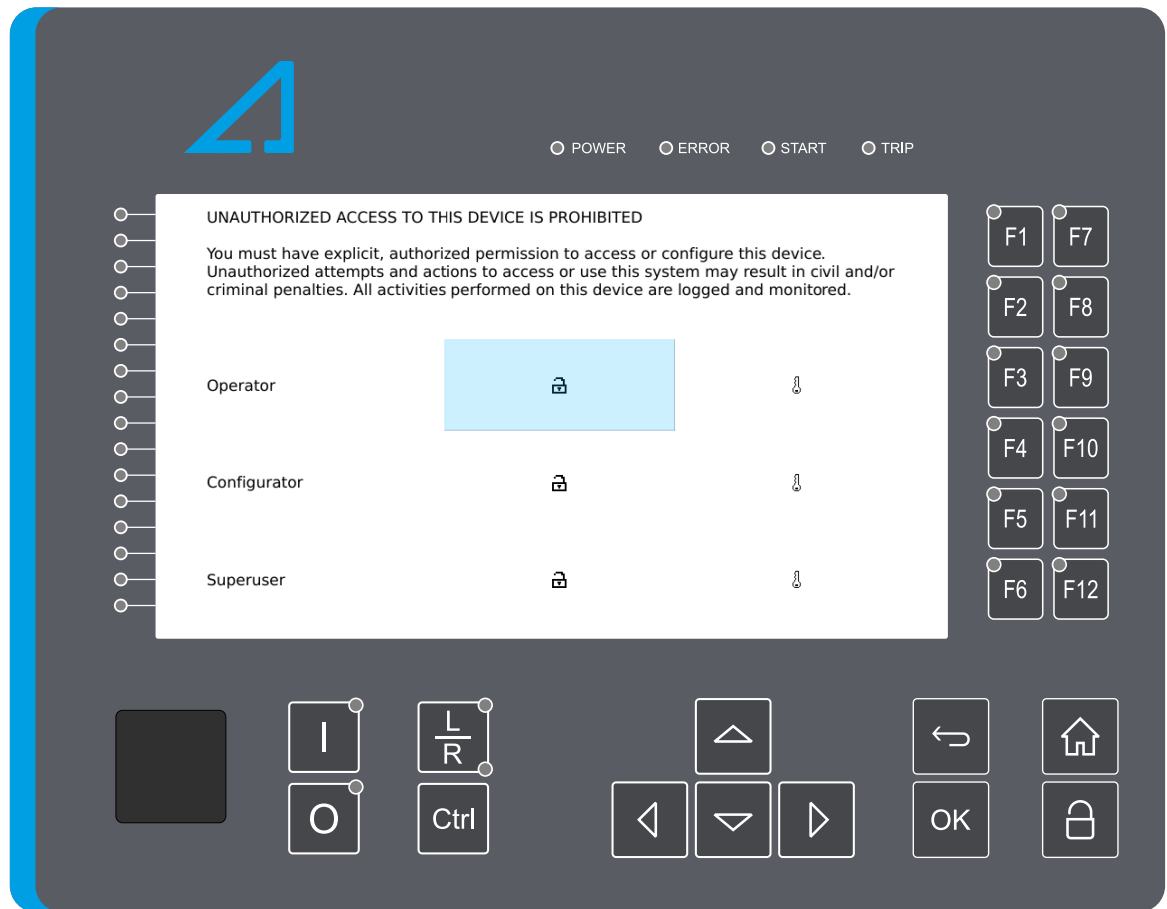
**NOTICE!**

Passwords can only be set locally in an HMI.

You can set a new password for a user level by selecting the key icon next to the user level's name. After this you can lock the user level by pressing the Return key while the lock is selected. If you need to change the password, you can select the key icon again and give a new password. To remove the password, set the password to "0" (zero). Please note that in order to do this the user level whose password is being changed must be unlocked.

As a general rule the access levels are divided as follows:

- User: Can view any menus and settings but cannot change any settings, nor operate breakers or other equipment.
- Operator: Can view any menus and settings but cannot change any settings BUT can operate breakers and other equipment.
- Configurator: Can change most settings such as basic protection pick-up levels or time delays, breaker control functions, signal descriptions etc. and can operate breakers and other equipment.
- Super user: Can change any setting and can operate breakers and other equipment.

### Advanced user access control settings

More detailed settings for user access can be found from *Monitoring* → *User Access Control* menu.

Table. 4.6.11 - 354. UAC settings.

| Name                                      | Range   | Default | Description   |
|---|---|---------|---|
| Enable user group - Operator              | <ul style="list-style-type: none"> <li>Enabled</li> <li>Disabled</li> </ul> | Enabled | Enables or disables "Operator" user group.  |
| Enable user group - Configurator          | <ul style="list-style-type: none"> <li>Enabled</li> <li>Disabled</li> </ul> | Enabled | Enables or disables "Configurator" user group.  |
| Minimum password length                   | 0...128   | 1       | Sets the minimum character length for passwords.  |
| Number of fail attempts before lock       | 0...1000  | 3       | Sets the number of failed attempts allowed before locking the user level.   |
| Lock period after max fail attempts       | 0...86400000 s  | 0 s     | Wait time after locking a user level.   |
| HMI session period before logout          | 5...86400 s   | 900 s   | Time delay for logging out in the HMI. Timer will start the countdown when there are no front panel button presses.             |
| Setting tool session period before logout | 5...86400 s   | 900 s   | Time delay for logging out in the setting tool. Timer will start the countdown when there are no key presses or mouse movement. |

Table. 4.6.11 - 355. UAC management.

| Name                                    | Range   | Default  | Description   |
|---|---|----------|---|
| Enable UAC management                   | <ul style="list-style-type: none"> <li>Enabled</li> <li>Disabled</li> </ul> | Disabled | If UAC has been enabled, the function will set default passwords for the user levels, if no passwords have been set. The function will also monitor if the passwords have been expired.   |
| Enable default passwords                | <ul style="list-style-type: none"> <li>Enabled</li> <li>Disabled</li> </ul> | Disabled | If enabled, user levels will use the default passwords, if no passwords have been set.<br>The default passwords are: <ul style="list-style-type: none"> <li>Operator: Oper17</li> <li>Configurator: Conf12</li> <li>Super user: Supr98</li> </ul> |
| Password change interval - Operator     | 0...1000 day(s)   | 0 day(s) | Required interval for changing passwords. If the password hasn't been changed on time, "Password expired" parameter will change to "True", diagnostic alarm will be activated and an entry to the audit log will be added.                        |
| Password change interval - Configurator | 0...1000 day(s)   | 0 day(s) |   |
| Password change interval - Superuser    | 0...1000 day(s)   | 0 day(s) |   |
| Password expired - Operator             | <ul style="list-style-type: none"> <li>False</li> <li>True</li> </ul>       | -        | If the password hasn't been changed before the "password change interval" has expired, this parameter will change to "True"   |

| Name                                      | Range   | Default | Description  |
|---|---|---------|--|
| Password expired - Configurator           | <ul style="list-style-type: none"> <li>False</li> <li>True</li> </ul> | -       | Indicates if the user level is using the default password or a user configured password. |
| Password expired - Superuser              | <ul style="list-style-type: none"> <li>False</li> <li>True</li> </ul> | -       |  |
| Default password unchanged - Operator     | <ul style="list-style-type: none"> <li>False</li> <li>True</li> </ul> | -       |  |
| Default password unchanged - Configurator | <ul style="list-style-type: none"> <li>False</li> <li>True</li> </ul> | -       |  |
| Default password unchanged - Superuser    | <ul style="list-style-type: none"> <li>False</li> <li>True</li> </ul> | -       |  |
| Password last changed - Operator          | DD/MM/YYYY<br>HH:mm:ss  | -       |  |
| Password last changed - Configurator      | DD/MM/YYYY<br>HH:mm:ss  | -       |  |
| Password last changed - Superuser         | DD/MM/YYYY<br>HH:mm:ss  | -       |  |

## 5 Communication

### 5.1 Connections menu

"Connections" menu is found under "Communication" menu. It contains all basic settings of the default back panel ethernet port and RS-485 serial port as well as settings of communication option cards.

Table. 5.1 - 356. Ethernet settings.

| Name                                      | Range  | Description  |
|---|--|--|
| IP address                                | 0.0.0.0...255.255.255.255  | Set IP address of the ethernet port in the back of the device.   |
| Netmask                                   | 0.0.0.0...255.255.255.255  | Set netmask of the ethernet port in the back of the device.  |
| Gateway                                   | 0.0.0.0...255.255.255.255  | Set gateway of the ethernet port in the back of the device.  |
| MAC-Address                               | 00-00-00-00-00-00...FF-FF-FF-FF-FF-FF  | Indication of MAC address of the device.   |
| Storm Protection                          | <ul style="list-style-type: none"> <li>• Disable</li> <li>• Enable</li> </ul>  | When enabled, the Storm protection functionality of the internal switch in the device is enabled. This functionality aims to protect the device from excess ethernet traffic caused by storm situation. When enabled, the packet rate allowed to pass through on the ingress port towards the device, is limited to 150 packets per second. Multicast packets are also included in the packet limit. |
| Double Ethernet card mode                 | <ul style="list-style-type: none"> <li>• Switch</li> <li>• HSR</li> <li>• PRP</li> </ul>   | If the device has a double ethernet option card it is possible to choose its mode.   |
| COM A and Ethernet option card connection | <ul style="list-style-type: none"> <li>• Block all</li> <li>• Allow both directions</li> <li>• Allow COM A to option card</li> <li>• Allow option card to COM A</li> </ul> | If the device has ethernet option card it is possible to determine the allowed direction of data.  |
| Double Ethernet link events               | <ul style="list-style-type: none"> <li>• Disable</li> <li>• Enable</li> </ul>  | Disables or enables "Double Ethernet Link A down" and "Double Ethernet Link B down" logic signals and events.  |
| Double Ethernet PRP ports                 | <ul style="list-style-type: none"> <li>• AB</li> <li>• BA</li> </ul>   | LanA and LanB port assignment for communication cards that support PRP.  |

Table. 5.1 - 357. Ethernet security settings.

| Name                       | Description   |
|----------------------------|---|
| Enable back Ethernet port  | Enable/Disable back panel Ethernet port communication.  |
| Enable front Ethernet port | Enable/Disable front panel Ethernet port communication. |

| Name                                | Description   |
|-------------------------------------|---|
| Enable SSH from front Ethernet port | Enable/Disable front panel Ethernet port SSH.   |
| Enable FTP                          | Enable/Disable FTP server.  |
| Enable discovery messages           | Enable/Disable discovery messages. Discovery messages enable <i>Tools</i> → <i>Device list</i> menu in AQtivate setting tool to find all of the devices in the network. |
| Enable script running               | Enable/Disable running scripts with <i>Tools</i> → <i>Run script</i> in AQtivate setting tool.  |

Virtual Ethernet enables the device to be connected to multiple different networks simultaneously via one physical Ethernet connection. Virtual Ethernet has its own separate IP address and network configurations. All Ethernet-based protocol servers listen for client connections on the IP addresses of both the physical Ethernet and the Virtual Ethernet.

Table. 5.1 - 358. Virtual Ethernet settings.

| Name                              | Description                             |
|-----------------------------------|---|
| Enable virtual adapter (No / Yes) | Enable virtual adapter. Off by default. |
| IP address                        | Set IP address of the virtual adapter.  |
| Netmask                           | Set netmask of the virtual adapter.     |
| Gateway                           | Set gateway of the virtual adapter.     |

Table. 5.1 - 359. Ethernet Option Card settings.

| Name                        | Range  | Default    | Description  |
|-----------------------------|--|------------|--|
| Ethernet card type          | <ul style="list-style-type: none"> <li>None</li> <li>SFP</li> <li>RJ45</li> </ul>                              | Ready only | Indicates the ethernet card type.  |
| Card mode                   | <ul style="list-style-type: none"> <li>COM A IP</li> <li>Single virtual IP</li> <li>Dual virtual IP</li> </ul> | COM A IP   |  |
| Rate limit                  | <ul style="list-style-type: none"> <li>No limit</li> <li>12.5Mb/1Mb</li> <li>30Mb/2Mb</li> </ul>               | No limit   |  |
| Clock synchronization mode  | <ul style="list-style-type: none"> <li>IRIG-B</li> <li>PTP</li> </ul>  | IRIG-B     | Clock synchronization mode selection. See " <a href="#">Time synchronization</a> " chapter for more information. |
| Card status                 | <ul style="list-style-type: none"> <li>Port1 link ok</li> <li>Port2 link ok</li> </ul>                         | Read only  |  |
| Card status (all)           | 0...4294967295   | Read only  |  |
| Port 1 dropped packet count | 0...4294967295   | Read only  |  |

| Name                                       | Range  | Default       | Description |
|--|--|---------------|-------------|
| Port 2 dropped packet count                | 0...4294967295   | Read only     |             |
| Enable port 1                              | <ul style="list-style-type: none"> <li>No</li> <li>Yes</li> </ul>  | No            |             |
| Port 1 SFP module status                   | <ul style="list-style-type: none"> <li>Error</li> <li>OK</li> </ul>  | Read only     |             |
| Port1 virtual Ethernet adapter IP address  | 0.0.0.0...255.255.255.255  | 10.15.1.0     |             |
| Port1 virtual Ethernet adapter netmask     | 0.0.0.0...255.255.255.255  | 255.255.255.0 |             |
| Port1 virtual Ethernet adapter gateway     | 0.0.0.0...255.255.255.255  | 10.15.1.254   |             |
| Port1 virtual Ethernet adapter MAC address | 00-00-00-00-00-00...FF-FF-FF-FF-FF-FF  | Read only     |             |
| Port 1 allowed protocols                   | <ul style="list-style-type: none"> <li>IEC61850</li> <li>GOOSE</li> <li>ModbusTCP</li> <li>IEC104</li> <li>DNP TCP</li> <li>FTP</li> <li>OPC UA</li> <li>NTP</li> <li>LPM communication</li> <li>Settingtool communication</li> <li>PTP</li> </ul> | None          |             |
| Port 1 link status events                  | <ul style="list-style-type: none"> <li>Enable</li> <li>Disable</li> </ul>  | Enable        |             |
| Port 2 SFP module status                   | <ul style="list-style-type: none"> <li>Error</li> <li>OK</li> </ul>  | Read only     |             |
| Port 2 link status events                  | <ul style="list-style-type: none"> <li>Enable</li> <li>Disable</li> </ul>  | Enable        |             |

The device is equipped with an RS-485 serial port. In the software it is identified as "Serial COM1" port.

Table. 5.1 - 360. Serial COM1 settings.

| Name    | Range   | Description                  |
|---------|---|------------------------------|
| Bitrate | <ul style="list-style-type: none"> <li>9600bps</li> <li>19200bps</li> <li>38400bps</li> </ul> | Bitrate used by RS-485 port. |

| Name     | Range  | Description                                 |
|----------|--|---|
| Databits | 7...8  | Databits used by RS-485 port.               |
| Parity   | <ul style="list-style-type: none"> <li>• None</li> <li>• Even</li> <li>• Odd</li> </ul>  | Paritybits used by RS-485 port.             |
| Stopbits | 1...2  | Stopbits used by RS-485 port.               |
| Protocol | <ul style="list-style-type: none"> <li>• None</li> <li>• ModbusRTU</li> <li>• ModbusIO</li> <li>• IEC103</li> <li>• SPA</li> <li>• DNP3</li> <li>• IEC101</li> </ul> | Communication protocol used by RS-485 port. |

The device supports communication option card type that has serial fiber ports (Serial COM2) an RS-232 port (Serial COM3).

Table. 5.1 - 361. Serial COM2 settings.

| Name       | Range  | Description   |
|------------|--|---|
| Bitrate    | <ul style="list-style-type: none"> <li>• 9600bps</li> <li>• 19200bps</li> <li>• 38400bps</li> </ul>  | Bitrate used by serial fiber channels.                |
| Databits   | 7...8  | Databits used by serial fiber channels.               |
| Parity     | <ul style="list-style-type: none"> <li>• None</li> <li>• Even</li> <li>• Odd</li> </ul>  | Paritybits used by serial fiber channels.             |
| Stopbits   | 1...2  | Stopbits used by serial fiber channels.               |
| Protocol   | <ul style="list-style-type: none"> <li>• None</li> <li>• ModbusRTU</li> <li>• ModbusIO</li> <li>• IEC103</li> <li>• SPA</li> <li>• DNP3</li> <li>• IEC101</li> </ul> | Communication protocol used by serial fiber channels. |
| Echo       | <ul style="list-style-type: none"> <li>• Off</li> <li>• On</li> </ul>  | Enable or disable echo.                               |
| Idle Light | <ul style="list-style-type: none"> <li>• Off</li> <li>• On</li> </ul>  | Idle light behaviour.                                 |

Table. 5.1 - 362. Serial COM3 settings.

| Name     | Range  | Description                                 |
|----------|--|---|
| Bitrate  | <ul style="list-style-type: none"> <li>9600bps</li> <li>19200bps</li> <li>38400bps</li> </ul>  | Bitrate used by RS-232 port.                |
| Databits | 7...8  | Databits used by RS-232 port.               |
| Parity   | <ul style="list-style-type: none"> <li>None</li> <li>Even</li> <li>Odd</li> </ul>  | Paritybits used by RS-232 port.             |
| Stopbits | 1...2  | Stopbits used by RS-232 port.               |
| Protocol | <ul style="list-style-type: none"> <li>None</li> <li>ModbusRTU</li> <li>ModbusIO</li> <li>IEC103</li> <li>SPA</li> <li>DNP3</li> <li>IEC101</li> </ul> | Communication protocol used by RS-232 port. |

## 5.2 Time synchronization

Time synchronization source can be selected with "Time synchronization" parameter at *Communication* → *Synchronization* → *General*.

Table. 5.2 - 363. General time synchronization source settings.

| Name                        | Range  | Description                               |
|-----------------------------|--|---|
| Time synchronization source | <ul style="list-style-type: none"> <li>Internal</li> <li>External NTP</li> <li>External serial</li> <li>IRIG-B</li> <li>PTP</li> </ul> | Selection of time synchronization source. |

### 5.2.1 Internal

If no external time synchronization source is available the mode should be set to "internal". This means that the device clock runs completely on its own. Time can be set to the device with AQtivate setting tool with *Commands* → *Sync Time* command or in the clock view from the HMI. When using *Sync time* command AQtivate sets the time to device the connected computer is currently using. Please note that the clock doesn't run when the device is powered off.

### 5.2.2 NTP

When enabled, the NTP (Network Time Protocol) service can use external time sources to synchronize the device's system time. The NTP client service uses an Ethernet connection to connect to the NTP time server. NTP can be enabled by setting the primary time server and the secondary time server parameters to the address of the system's NTP time source(s).

Table. 5.2.2 - 364. Server settings.

| Name                          | Range                     | Description   |
|-------------------------------|---------------------------|---|
| Primary time server address   | 0.0.0.0...255.255.255.255 | Defines the address of the primary NTP server. Setting this parameter at "0.0.0.0" means that the server is not in use.               |
| Secondary time server address | 0.0.0.0...255.255.255.255 | Defines the address of the secondary (or backup) NTP server. Setting this parameter at "0.0.0.0" means that the server is not in use. |
| NTP version                   | 3...4                     | Defines the NTP version used.   |

Table. 5.2.2 - 365. Status.

| Name                        | Range   | Description  |
|-----------------------------|---|--|
| NTP quality for events      | <ul style="list-style-type: none"> <li>• No sync</li> <li>• Synchronized</li> </ul> | Displays the status of the NTP time synchronization at the moment. <b>NOTE:</b> This indication is not valid if another time synchronization method is used (external serial). |
| NTP-processed message count | 0...4294967295  | Displays the number of messages processed by the NTP protocol.   |

Additionally, the time zone of the device can be set by connecting to the device and the selecting the time zone at *Commands* → *Set time zone* in AQtivate setting tool.

### 5.2.3 PTP

The device supports IEEE 1588v2 precision time protocol synchronization in accordance with the PTP profiles defined in IEEE C37.238-2011/2017 and IEC 61850-9-3 (2016). The device can be configured to operate as a master, as a slave or in an automatic mode where the role is selected dynamically.

In typical operation the device functions as an ordinary clock and is configured either in slave mode or in auto mode. In both cases the device synchronizes to an external Grandmaster and does not normally act as a time source when a higher-priority clock is available. This is common in networks where a GPS-synchronized Grandmaster is present.

When operating in auto mode the device participates in the Best Master Clock Algorithm (BMCA) continuously comparing its clock quality with other PTP devices in the network. Based on this evaluation it automatically assumes the appropriate role—either master or slave.

When the device is explicitly configured in master mode it behaves as a pre-master if a GPS-synchronized Grandmaster is present. In this condition it advertises its clock properties but does not take over the Grandmaster role unless the higher-priority clock becomes unavailable.

To ensure redundancy at least one device often a protection relay is typically assigned a higher priority or explicitly set to master to act as a backup Grandmaster. If the GPS-synchronized master becomes unavailable this device takes over seamlessly and continuous time distribution.

If the device becomes a Grandmaster either because it is explicitly configured as master or because BMCA selects it in auto mode it provides the reference time for other devices. In this state the device is not synchronized to GPS and the time source relies solely on its internal oscillator. This ensures continued synchronization within the network even when the GPS-based master is lost although the absolute accuracy depends on the internal clock stability.

## Settings

Select PTP as the time synchronization source from *Communication* → *Synchronization* → *General* menu.

The following settings are available in *Communication* → *Synchronization* → *PTP* menu.

Table. 5.2.3 - 366. PTP time synchronization settings.

| Name                     | Range  | Description   |
|--------------------------|--|---|
| Power profile            | <ul style="list-style-type: none"> <li>None</li> <li>IEEE C37-238-2011</li> <li>IEC61850-9-3</li> <li>IEEE C37-238-2017</li> </ul> | Defines used power profile.   |
| Role                     | <ul style="list-style-type: none"> <li>Auto (Default)</li> <li>Master</li> <li>Slave</li> </ul>                                    | In Auto mode, the device can take both the role of a clock source and clock consumer. In Master mode the device is forced to consider itself to be a clock source. In Slave mode the device is forced to be a clock consumer. |
| Mechanism                | <ul style="list-style-type: none"> <li>P2P (Default)</li> <li>E2E</li> </ul>   | Delay measurement mechanism used. Peer-to-peer can utilize the PTP enabled switches as transparent to boundary clocks while End-to-end must be used if non-PTP enabled switches are found in the network.                     |
| Domain number            | 0...255  | PTP devices can be set to belong to a grouping called domain. Devices in same domain is primarily being synchronized together.  |
| Log announce interval    |  | Mean time interval between successive announce messages.  |
| Log delayReq interval    |  | The minimum permitted mean time interval between successive Delay_Req messages  |
| Log sync interval        |  | Mean time interval between successive sync messages   |
| Sync receipt timeout     |  | Number of sync intervals that must pass without receipt of an sync message before the occurrence of the event SYNC_RECEIPT_TIMEOUT_EXPIRES  |
| Announce receipt timeout |  | Number of announce intervals that must pass without receipt of an announce message before the occurrence of the event ANNOUNCE_RECEIPT_TIMEOUT_EXPIRES  |
| Clock class              |  | The traceability, synchronization state and expected performance of the time or frequency distributed by the Grandmaster PTP Instance   |
| Clock accuracy           |  | The expected accuracy of a PTP Instance when it is the Grandmaster PTP Instance, or in the event it becomes the Grandmaster PTP Instance  |
| Priority 1               |  | Priority setting used in the execution of the best master clock algorithm. Lower values take precedence   |
| Priority 2               |  | Priority setting used in the execution of the best master clock algorithm. Lower values take precedence   |

| Name            | Range   | Description  |
|-----------------|---|--|
| VLAN enable     | <ul style="list-style-type: none"> <li>Disabled</li> <li>Enabled</li> </ul> | Enable VLAN header for PTP communication                 |
| VLAN priority   | 0...7   | Priority setting for VLAN                                |
| VLAN ID         | 0...4095  | VLAN identification setting                              |
| Reconfigure PTP | <ul style="list-style-type: none"> <li>-</li> <li>Reconfigure</li> </ul>    | Parameter to trig reconfiguration of the PTP application |

## Status indications

The following status indications are available in *Communication* → *Synchronization* → *PTP* menu.

Table. 5.2.3 - 367. PTP status indications

| Name            | Description   |
|-----------------|---|
| State           | State of the PTP application (Master, Slave, Listening).                            |
| Best master     | Identification of best master in network. Id consist of MAC address plus id number. |
| Last receive    | Time when last synchronization frame was received.                                  |
| Message sent    | Diagnostic message counter.   |
| Message receive | Diagnostic message counter.   |
| PTP timesource  | Diagnostic number describing the current time source.                               |

## 5.3 Communication protocols

The following chapters will describe all available communication protocols. The device includes an RJ-45 ethernet port and an RS-485 serial port, which are able to use communication protocols. See other options for communication ports under "[Construction and installation](#)".

### 5.3.1 IEC 61850

The user can enable the IEC 61850 protocol in device models that support this protocol at *Communication* → *Protocols* → *IEC61850*. The device supports both Edition 1 and 2 of IEC 61850. The following services are supported by the device:

- Up to eight (8) data sets
- Report Control Blocks (both buffered and unbuffered reporting)
- Control ('Direct operate with normal security', 'Select before operate with normal security', 'Direct with enhanced security' and 'Select before operate with enhanced security' control sequences)
- Disturbance recording file transfer
- GOOSE
- Time synchronization

The device's current IEC 61850 setup can be viewed and edited with the IEC61850 tool (*Tools* → *Communication* → *IEC 61850*).

## Settings

The general setting parameters for the IEC 61850 protocol are visible both in AQtivate and in the local HMI. The settings are described in the table below.

Table. 5.3.1 - 368. General settings.

| Name   | Range  | Step     | Default        | Description   |
|--|--|----------|----------------|---|
| Enable IEC 61850                                 | <ul style="list-style-type: none"> <li>Disabled</li> <li>Enabled</li> </ul>                        | -        | Disabled       | Enables and disables the IEC 61850 communication protocol.  |
| Reconfigure IEC 61850                            | <ul style="list-style-type: none"> <li>-</li> <li>Reconfigure</li> </ul>                           | -        | -              | Reconfigures IEC 61850 settings.  |
| IEC61850 edition                                 | <ul style="list-style-type: none"> <li>Ed1</li> <li>Ed2</li> </ul>                                 | -        | -              | Displays the IEC61850 edition used by the device. Edition can be chosen by loading a new CID file at <i>Tools</i> → <i>Communication</i> → <i>IEC 61850</i> with <i>Open</i> button.  |
| Control Authority switch                         | <ul style="list-style-type: none"> <li>Remote Control</li> <li>Station Level Control</li> </ul>    | -        | Remote Control | The device can be set to allow object control via IEC 61850 only from clients that are of category Station level control. This would mean that other Remote control clients would not be allowed to control. In Remote control mode all IEC 61850 clients of both remote and station level category are allowed to control objects. |
| Ethernet port                                    | <ul style="list-style-type: none"> <li>All</li> <li>COM A</li> <li>Double ethernet card</li> </ul> | -        | All            | Determines which ports use IEC61850. Parameter is visible if double ethernet option card is found in the device.  |
| Configure GOOSE Subscriber from CID file allowed | <ul style="list-style-type: none"> <li>Disabled</li> <li>Allowed</li> </ul>                        | -        | Disabled       | In edition 2 of IEC 61850 GOOSE subscriber configuration is a part of the CID file. Determines if it is possible to import published GOOSE settings of another device with a CID file and set them to GOOSE input at <i>Tools</i> → <i>Communication</i> → <i>IEC 61850</i> → <i>GOOSE subscriptions</i> .                          |
| General deadband                                 | 0.1...10.0 %   | 0.1 %    | 2 %            | Determines the general data reporting deadband settings.  |
| Active energy deadband                           | 0.1...1000.0 kWh   | 0.1 kWh  | 2 kWh          | Determines the data reporting deadband settings for this measurement.   |
| Reactive energy deadband                         | 0.1...1000.0 kVar  | 0.1 kVar | 2 kVar         | Determines the data reporting deadband settings for this measurement.   |
| Active power deadband                            | 0.1...1000.0 kW  | 0.1 kW   | 2 kW           | Determines the data reporting deadband settings for this measurement.   |
| Reactive power deadband                          | 0.1...1000.0 kVar  | 0.1 kVar | 2 kVar         | Determines the data reporting deadband settings for this measurement.   |
| Apparent power deadband                          | 0.1...1000.0 kVA   | 0.1 kVA  | 2 kVA          | Determines the data reporting deadband settings for this measurement.   |

| Name                       | Range  | Step    | Default | Description   |
|----------------------------|--|---------|---------|---|
| Power factor deadband      | 0.01...0.99  | 0.01    | 0.05    | Determines the data reporting deadband settings for this measurement.   |
| Frequency deadband         | 0.01...1.00 Hz   | 0.01 Hz | 0.1 Hz  | Determines the data reporting deadband settings for this measurement.   |
| Current deadband           | 0.01...50.00 A   | 0.01 A  | 5 A     | Determines the data reporting deadband settings for this measurement.   |
| Residual current deadband  | 0.01...50.00 A   | 0.01 A  | 0.2 A   | Determines the data reporting deadband settings for this measurement.   |
| Voltage deadband           | 0.01...5000.00 V   | 0.01 V  | 200 V   | Determines the data reporting deadband settings for this measurement.   |
| Residual voltage deadband  | 0.01...5000.00 V   | 0.01 V  | 200 V   | Determines the data reporting deadband settings for this measurement.   |
| Angle measurement deadband | 0.1...5.0 deg  | 0.1 deg | 1 deg   | Determines the data reporting deadband settings for this measurement.   |
| mA deadband                | 0.01...5.00 mA   | 0.01 mA | 0.10 mA | Determines the data reporting deadband settings for this measurement.   |
| Integration time           | 0...10 000 ms  | 1 ms    | 0 ms    | Determines the integration time of the protocol. If this parameter is set to "0 ms", no integration time is in use.<br>See chapter " <a href="#">Integration time</a> " for more information. |
| GOOSE Ethernet port        | <ul style="list-style-type: none"> <li>All</li> <li>COM A</li> <li>Double ethernet card</li> </ul> | -       | All     | Determines which ports can use GOOSE communication. Visible if double ethernet option card is found in the device.  |

For more information on the IEC 61850 communication protocol support, please refer to the conformance statement documents (<https://www.arcteq.com/documents-and-software/> → AQ 200 series → Resources).

### 5.3.1.1 Logical device mode and logical node mode

Every protection block has its own behavior (LNBeh). This behavior is determined using a combination of the protection block's mode (LNMod) and the device's mode (LDMod).

In IEC61850 mode,

- LNMod can be reported and controlled through Mod data object in all logical nodes.
- LNBeh can be reported through Beh data object in all logical nodes.
- LDMod is only visible through logical node zero's Mod data object (LLN0.Mod).

#### Mode and behavior values

There are 5 values defined for mode and behavior: On, Blocked, Test, Test / Blocked and Off.

Table. 5.3.1.1 - 369. Behavior descriptions.

| LNBeh                 | On               | Blocked          | Test          | Test / Blocked | Off                  |
|-----------------------|------------------|------------------|---------------|----------------|----------------------|
| Function working      | Yes              | Yes              | Yes           | Yes            | No                   |
| Data quality          | Relevant to data | Relevant to data | q.test = True | q.test = True  | q.validity = Invalid |
| Output to process     | Yes              | No               | Yes           | No             | No                   |
| Accept normal control | Yes              | Yes              | No            | No             | No                   |
| Accept test control   | No               | No               | Yes           | Yes            | No                   |

The communication services for the **data object Mod** do not care about the status of the LNBeh. Mod will always accept commands with **q.test = False**.

**Data objects Mod, Beh and Health** will always have **q.validity = Good**. Regardless of the status of LNBeh, the quality test attribute of Mod, Beh and Health shall be **q.test = False**.

### Behavior determination

The values for LDMod and LNMod are settable by the user by using HMI, setting tool, or IEC 61850 client. The value for LNBeh are then determined using following rules.

- If either LDMod or LNMod is Off, LNBeh is Off.
- Otherwise,
  - If either LDMod or LNMod is set to either "Test" or "Test / Blocked" mode, LNBeh is in Test mode.
  - If either LDMod or LNMod is set to either "Blocked" or "Test / Blocked" mode, LNBeh is in Blocked mode.
  - If LNBeh still doesn't have anything, LNBeh is "On".

All the possible combinations are laid out in the following table.

Table. 5.3.1.1 - 370. All possible logical device and logical node combinations.

| LDMod          | LNMod          | LNBeh          |
|----------------|----------------|----------------|
| Off            | Off            | Off            |
|                | Test / Blocked | Off            |
|                | Test           | Off            |
|                | Blocked        | Off            |
|                | On             | Off            |
| Test / Blocked | Off            | Off            |
|                | Test / Blocked | Test / Blocked |
|                | Test           | Test / Blocked |
|                | Blocked        | Test / Blocked |
|                | On             | Test / Blocked |

| LDMod   | LNMod          | LNBeh          |
|---------|----------------|----------------|
| Test    | Off            | Off            |
|         | Test / Blocked | Test / Blocked |
|         | Test           | Test           |
|         | Blocked        | Test / Blocked |
|         | On             | Test           |
| Blocked | Off            | Off            |
|         | Test / Blocked | Test / Blocked |
|         | Test           | Test / Blocked |
|         | Blocked        | Blocked        |
|         | On             | Blocked        |
| On      | Off            | Off            |
|         | Test / Blocked | Test / Blocked |
|         | Test           | Test           |
|         | Blocked        | Blocked        |
|         | On             | On             |

### Processing of incoming data in different behaviors

This part only applies to incoming data with quality information.

The table below gives the functional processing of the data in different behavior states **as defined by the standard**. Logical nodes should process receiving data according to their quality information:

- Processed as valid - Reacts according to the quality.
- Processed as invalid - Reacts as if the quality of the data had been invalid.
- Processed as questionable - The application decides how to consider the status value.
- Not processed - Do not belong to communication services, no quality bit can be evaluated.

Table. 5.3.1.1 - 371. Processing of incoming data in different behaviors as defined by the standard.

|   | On                        | Blocked                   | Test                      | Test / Blocked            | Off           |
|---|---------------------------|---------------------------|---------------------------|---------------------------|---------------|
| q.validity = Good<br>q.test = False         | Processed as valid        | Processed as valid        | Processed as valid        | Processed as valid        | Not processed |
| q.validity = Questionable<br>q.test = False | Processed as questionable | Processed as questionable | Processed as questionable | Processed as questionable | Not processed |
| q.validity = Good<br>q.test = True          | Processed as invalid      | Processed as invalid      | Processed as valid        | Processed as valid        | Not processed |

|   | On                   | Blocked              | Test                      | Test / Blocked            | Off           |
|---|----------------------|----------------------|---------------------------|---------------------------|---------------|
| q.validity = Questionable<br>q.test = True      | Processed as invalid | Processed as invalid | Processed as questionable | Processed as questionable | Not processed |
| q.validity = Invalid<br>q.test = True/<br>False | Processed as invalid | Processed as invalid | Processed as invalid      | Processed as invalid      | Not processed |

Arcteq's implementation treats "Processed as questionable" and "Processed as invalid" in the same way with "Not processed". Only "Processed as valid" is passed to the application.

Table. 5.3.1.1 - 372. Arcteq's implementation of processing of incoming data in different behaviors.

|   | On                 | Blocked            | Test               | Test / Blocked     | Off |
|---|--------------------|--------------------|--------------------|--------------------|-----|
| q.validity = Good<br>q.test = False         | Processed as valid | Processed as valid | Processed as valid | Processed as valid |     |
| q.validity = Questionable<br>q.test = False |                    |                    |                    |                    |     |
| q.validity = Good<br>q.test = True          |                    |                    | Processed as valid | Processed as valid |     |
| q.validity = Questionable<br>q.test = True  |                    |                    |                    |                    |     |
| q.validity = Invalid<br>q.test = True/False |                    |                    |                    |                    |     |

## Using mode and behavior

Enabling LDMod and LNMod changing can be done at *General* → *Device info*.

Table. 5.3.1.1 - 373. Parameters to allow changing of LNMod and LDMod.

| Name                         | Range   | Default    | Description   |
|------------------------------|---|------------|---|
| Allow setting of device mode | <ul style="list-style-type: none"> <li>Prohibited</li> <li>From HMI/setting tool only</li> <li>Allowed</li> </ul> | Prohibited | <p>Allows global mode to be modified from setting tool, HMI and IEC61850.</p> <p>Prohibited: Cannot be changed.</p> <p>From HMI/setting tool only: Can only be changed from the setting tool or HMI.</p> <p>Allowed: Can be changed from the setting tool, HMI, and IEC 61850 client.</p> |

| Name                                | Range   | Default    | Description   |
|-------------------------------------|---|------------|---|
| Allow setting of individual LN mode | <ul style="list-style-type: none"> <li>Prohibited</li> <li>From HMI/setting tool only</li> <li>Allowed</li> </ul> | Prohibited | <p>Allow local modes to be modified from setting tool, HMI and IEC61850.</p> <p>This parameter is visible only when "Allow setting of device mode" is enabled.</p> <p>Prohibited: Cannot be changed.</p> <p>From HMI/setting tool only: Can only be changed from the setting tool or HMI</p> <p>Allowed: Can be changed from the setting tool, HMI, and IEC 61850 client.</p> |

When enabled it is possible to change LDMoD at *Communication* → *Protocols* → *IEC61850*.

Table. 5.3.1.1 - 374. Parameter for changing logical device mode.

| Name                         | Range  | Default | Description  |
|------------------------------|--|---------|--|
| Allow setting of device mode | <ul style="list-style-type: none"> <li>On</li> <li>Blocked</li> <li>Test</li> <li>Test/Blocked</li> <li>Off</li> </ul> | On      | <p>Set mode of logical device.</p> <p>This parameter is visible only when <i>Allow setting of device mode</i> is enabled in <i>General</i> menu.</p> |

Each protection, control and monitoring function has its own logical node mode which can be changed individually. This parameter is found in the functions *Info*-menu. Each function also reports its behavior. Behavior of the function is influenced by the status of the device mode setting and the functions mode setting.

Table. 5.3.1.1 - 375. LNMod parameters.

| Name        | Range  | Default | Description   |
|-------------|--|---------|---|
| LN mode     | <ul style="list-style-type: none"> <li>On</li> <li>Blocked</li> <li>Test</li> <li>Test/Blocked</li> <li>Off</li> </ul> | On      | <p>Set mode of function logical node.</p> <p>This parameter is visible only when <i>Allow setting of individual LN mode</i> is enabled in <i>General</i> menu.</p>              |
| LN behavior | <ul style="list-style-type: none"> <li>On</li> <li>Blocked</li> <li>Test</li> <li>Test/Blocked</li> <li>Off</li> </ul> | On      | <p>Displays the mode of the function logical node.</p> <p>This parameter is visible only when <i>Allow setting of individual LN mode</i> is enabled in <i>General</i> menu.</p> |

### 5.3.1.2 GOOSE

Arcteq devices support both GOOSE publisher and GOOSE subscriber. GOOSE subscriber is enabled with the "GOOSE subscriber enable" parameter at *Communication* → *Protocols* → *IEC 61850/GOOSE*. The GOOSE inputs are configured using either the local HMI or the AQtivate software.

There are up to 64 GOOSE inputs available for use. Each of the GOOSE inputs also has a corresponding input quality signal which can also be used in internal logic. The quality is good, when the input quality status is "low" (that is, when the quality is marked as "0"). The value of the input quality can switch on as a result of a GOOSE time-out or a configuration error, for example. The status and quality of the various logical input signals can be viewed at the *GOOSE IN status* and *GOOSE IN quality* tabs at *Control* → *Device I/O* → *Logical signals*.

### General GOOSE setting

The table below presents general settings for GOOSE publisher.

Table. 5.3.1.2 - 376. General GOOSE publisher settings.

| Name                                 | Range   | Description   |
|--------------------------------------|---|---|
| GOOSE control block 1 simulation bit | <ul style="list-style-type: none"> <li>Disabled (Default)</li> <li>Enabled</li> </ul> | The publisher will publish frames with simulation bit active if enabled. For GOOSE simulation testing purposes. |
| GOOSE control block 2 simulation bit |   |   |

The table below presents general settings for GOOSE subscriber

Table. 5.3.1.2 - 377. General GOOSE subscriber settings.

| Name                                   | Range   | Description  |
|--|---|--|
| GOOSE subscriber enable                | <ul style="list-style-type: none"> <li>Disabled (Default)</li> <li>Enabled</li> </ul>       | Enables or disables GOOSE subscribing for the device.  |
| Not used GOOSE input Quality           | <ul style="list-style-type: none"> <li>Bad quality (1)</li> <li>Good quality (0)</li> </ul> | Defines what state should GOOSE input quality signal to be in the logic if the input has been set as "disabled".   |
| Subscriber checks GoCRef               | <ul style="list-style-type: none"> <li>No (Default)</li> <li>Yes</li> </ul>                 | When subscriber sees GOOSE frame it checks APPID and Conf. Rev but can also check if GoCRef or SqNum match.  |
| Subscriber checks SqNum                |   |  |
| Subscriber process simulation messages | <ul style="list-style-type: none"> <li>No (Default)</li> <li>Yes</li> </ul>                 | Subscriber can be set to process frames which are published with simulation bit high if enabled.<br>The subscriber can still subscribe to non-simulated frames from a publisher until that a simulated frame is received from a publisher. From that point on, only simulated frames are accepted from that publisher.<br>For other publishers, non-simulated frames are accepted normally (given no simulated frame is received from that publisher).<br>This behavior ends when the setting is set back to No. |

### GOOSE input settings

The table below presents the different settings available for all 64 GOOSE inputs.

These settings can be found from *Communication* → *Protocols* → *IEC61850/GOOSE* → *GOOSE Input Settings*.

Table. 5.3.1.2 - 378. GOOSE input settings.

| Name                               | Range  | Description  |
|------------------------------------|--|--|
| In use                             | <ul style="list-style-type: none"> <li>No (Default)</li> <li>Yes</li> </ul>  | Enables and disables the GOOSE input in question.  |
| Application ID ("AppID")           | 0x0...0x3FFF   | Defines the application ID that will be matched with the publisher's GOOSE control block.  |
| Configuration revision ("ConfRev") | 1...2 <sup>32</sup> -1   | Defines the configuration revision that will be matched with the publisher's GOOSE control block.  |
| Data index ("DataIdx")             | 0...99   | Defines the data index of the value in the matched published frame. It is the status of the GOOSE input.   |
| NextIdx is quality                 | <ul style="list-style-type: none"> <li>No (Default)</li> <li>Yes</li> </ul>  | Selects whether or not the next received input is the quality bit of the GOOSE input.  |
| Data type                          | <ul style="list-style-type: none"> <li>Boolean (Default)</li> <li>Integer</li> <li>Unsigned</li> <li>Floating point</li> </ul> | Selects the data type of the GOOSE input.  |
| Control block reference            | -  | GOOSE subscriber can be set to check the GCB reference of the published GOOSE frame. This setting is automatically filled when Ed2 GOOSE configuration is done by importing cid file of the publisher. |

## GOOSE input descriptions

Each of the GOOSE inputs can be given a description. The user defined description are displayed in most of the menus:

- logic editor
- matrix
- block settings
- event history
- disturbance recordings
- etc.

These settings can be found from *Control* → *Device IO* → *Logical Signals* → *GOOSE IN Description*.

Table. 5.3.1.2 - 379. GOOSE input user description.

| Name                           | Range             | Default    | Description   |
|--------------------------------|-------------------|------------|---|
| User editable description GI x | 1...31 characters | GOOSE IN x | Description of the GOOSE input. This description is used in several menu types for easier identification. |

## GOOSE input values

Each of the GOOSE subscriber inputs (1...64) have indications listed in the following table. These indications can be found from *Communication* → *Protocols* → *IEC61850/GOOSE* → *GOOSE input values*.

Table. 5.3.1.2 - 380. GOOSE input indications

| Name                          | Range   | Description   |
|-------------------------------|---|---|
| Subscription status           | <ul style="list-style-type: none"> <li>Not Active</li> <li>Active</li> </ul>  | When active correct data received and passed to application.  |
| Processing simulation message | <ul style="list-style-type: none"> <li>False</li> <li>True</li> </ul>   | When true subscriber is processing simulation frames for this input (and rejecting non-simulated frames). |
| Needs commissioning           | <ul style="list-style-type: none"> <li>False</li> <li>True</li> </ul>   | When true configuration doesn't match the received frame (goCBRef, confRev).                              |
| Last received state number    | 0...4294967295  | Status number (stNum) of the last data passed to application.   |
| GOOSE IN X boolean value      | 0...1   | GOOSE input 1...64 boolean value.   |
| GOOSE IN X analog value       | -3.4E+38...3.4E+38  | GOOSE input 1...64 analog value.  |
| GOOSE IN X quality            | <ul style="list-style-type: none"> <li>Old data</li> <li>Failure</li> <li>Oscillatory</li> <li>Bad reference</li> <li>Out of range</li> <li>Overflow</li> <li>Invalid</li> <li>Reserved/ Questionable</li> <li>Operator blocked</li> <li>Test</li> <li>Substituted</li> <li>Inaccurate</li> <li>Inconsistent</li> </ul> | GOOSE input quality indication.   |
| GOOSE IN X time               | DD/MM/YYYY<br>HH:MM:SS  | Time when publisher sent GOOSE frame.   |
| GOOSE IN X time fraction      | 0...4294967295 μs   | Microseconds of the publisher GOOSE frame.  |

## GOOSE events

GOOSE signals generate events from status changes. The user can select which event messages are stored in the main event buffer: ON, OFF, or both. The events triggered by the function are recorded with a time stamp and with process data values. The time stamp resolution is 1 ms.

Table. 5.3.1.2 - 381. GOOSE event

| Event block name | Event name   | Description   |
|------------------|--|---|
| GOOSE1...GOOSE2  | GOOSE IN 1...64 ON/OFF                                   | Status change of GOOSE input.   |
| GOOSE3...GOOSE4  | GOOSE IN 1...64 quality Bad/Good                         | Status change of GOOSE inputs quality.  |
| GOOSE5...GOOSE6  | GOOSE Subscription status 1...64 Active/Not active       | When active correct data received and passed to application.  |
| GOOSE7...GOOSE8  | GOOSE Processing simulated messages 1...64 True/False    | When true subscriber is processing simulation frames for this input (and rejecting non-simulated frames). |
| GOOSE9...GOOSE10 | GOOSE Subscription needs commissioning 1...64 True/False | When true configuration doesn't match the received frame (goCBRef, confRev).                              |

### Setting the publisher

The configuration of the GOOSE publisher is done using the IEC 61850 tool in AQtivate (*Tools* → *Communication* → *IEC 61850*). Refer to *AQtivate-200 Instruction manual* for more information on how to set up GOOSE publisher.

## 5.3.2 Modbus TCP and Modbus RTU

The device supports both Modbus TCP and Modbus RTU communication. Modbus TCP uses the Ethernet connection to communicate with Modbus TCP clients. Modbus RTU is a serial protocol that can be selected for the available serial ports.

The user can enable the Modbus TCP protocol at *Communication* → *Protocols* → *Modbus TCP*. The user can enable the Modbus RTU protocol at *Communication* → *Connections*.

The following Modbus function types are supported:

- Read multiple holding registers (function code 3)
- Write single holding register (function code 6)
- Write multiple holding registers (function code 16)
- Read/Write multiple registers (function code 23)

The following data can be accessed using both Modbus TCP and Modbus RTU:

- Device measurements
- Device I/O
- Commands
- Events
- Time

Once the configuration file has been loaded, the user can access the Modbus map of the device via the AQtivate software (*Tools* → *Communication* → *Modbus Map*). Please note that holding registers start from 1. Some masters might begin numbering holding register from 0 instead of 1; this will cause an offset of 1 between the device and the master. Modbus map can be edited with Modbus Configurator (*Tools* → *Communication* → *Modbus Configurator*).

Table. 5.3.2 - 382. Modbus TCP settings.

| Parameter         | Range   | Description  |
|-------------------|---|--|
| Enable Modbus TCP | <ul style="list-style-type: none"> <li>Disabled</li> <li>Enabled</li> </ul>   | Enables and disables the Modbus TCP on the Ethernet port.  |
| IP port           | 0...65 535  | Defines the IP port used by Modbus TCP. The standard port (and the default setting) is 502.  |
| Ethernet port     | <ul style="list-style-type: none"> <li>All</li> <li>COM A</li> <li>Double Ethernet card</li> </ul>                                    | Defines which ethernet ports are available for Modbus connection. Visible if any double ethernet option card is installed in the device.             |
| Event read mode   | <ul style="list-style-type: none"> <li>Get oldest available</li> <li>Continue previous connection</li> <li>New events only</li> </ul> | Get oldest event possible (Default)<br>Continue with the event idx from previous connection<br>Get only new events from connection time and forward. |

Table. 5.3.2 - 383. Modbus RTU settings.

| Parameter     | Range   | Description  |
|---------------|---------|--|
| Slave address | 1...247 | Defines the Modbus RTU slave address for the unit. |

## Reading events

Modbus protocol does not support time-stamped events by standard definition. This means that every vendor must come up with their own definition how to transfer events from the device to the client. Events can be read from HR17...HR22 holding registers. HR17 contains the event-code, HR18...20 contains the time-stamp in UTC, HR21 contains a sequential index and HR22 is reserved for future expansion. See the Modbus Map for more information. The event-codes and their meaning can be found from Event list (*Tools* → *Events ang Logs* → *Event list* in setting tool). The event-code in HR17 is 0 if no new events can be found in the device event-buffer. Every time HR17 is read from client the event in event-buffer is consumed and on following read operation the next un-read event information can be found from event registers. HR11...HR16 registers contains a back-up of last read event. This is because some users want to double-check that no events were lost

### 5.3.3 IEC 103

IEC 103 is the shortened form of the international standard IEC 60870-5-103. The device is able to run as a secondary (slave) station. The IEC 103 protocol can be selected for the serial ports that are available in the device. A primary (master) station can then communicate with the device and receive information by polling from the slave device. The transfer of disturbance recordings is not supported.

The user can enable the IEC 103 protocol at *Communication* → *Connections*.

**NOTE:** Once the configuration file has been loaded, the IEC 103 map of the device can be found in the AQtivate software (*Tools* → *IEC 103 map*).

Table. 5.3.3 - 384. IEC 103 settings.

| Name                 | Range         | Step | Default | Description                                       |
|----------------------|---------------|------|---------|---|
| Slave address        | 1...254       | 1    | 1       | Defines the IEC 103 slave address for the unit.   |
| Measurement interval | 0...60 000 ms | 1 ms | 2000 ms | Defines the interval for the measurements update. |

The following table presents the setting parameters for the IEC 103 protocol.

### 5.3.4 IEC 101/104

The standards IEC 60870-5-101 and IEC 60870-5-104 are closely related. Both are derived from the IEC 60870-5 standard. On the physical layer the IEC 101 protocol uses serial communication whereas the IEC 104 protocol uses Ethernet communication. The IEC 101/104 implementation works as a slave in the unbalanced mode.

For detailed information please refer to the IEC 101/104 interoperability document (<https://www.arcteq.com/documents-and-software/> → AQ-200 series → Resources → "AQ-200 IEC101 & IEC104 interoperability").

The user can enable the IEC104 protocol at *Communication* → *Protocols* → *IEC101/104*. The user can enable the IEC101 protocol at *Communication* → *Connections*.

### IEC 101 settings

Table. 5.3.4 - 385. IEC 101 settings.

| Name                            | Range      | Step | Default | Description  |
|---------------------------------|------------|------|---------|--|
| Common address of ASDU          | 0...65 534 | 1    | 1       | Defines the common address of the application service data unit (ASDU) for the IEC 101 communication protocol. |
| Common address of ASDU size     | 1...2      | 1    | 2       | Defines the size of the common address of ASDU.  |
| Link layer address              | 0...65 534 | 1    | 1       | Defines the address for the link layer.  |
| Link layer address size         | 1...2      | 1    | 2       | Defines the address size of the link layer.  |
| Information object address size | 2...3      | 1    | 3       | Defines the address size of the information object.  |
| Cause of transmission size      | 1...2      | 1    | 2       | Defines the cause of transmission size.  |

## IEC101/104 measurement scaling coefficients

Table. 5.3.4 - 386. Measurement scaling coefficient settings.

| Name                            | Range  | Default    | Description  |
|---------------------------------|--|------------|--|
| General scaling coef.           | <ul style="list-style-type: none"> <li>• No scaling</li> <li>• 1/10</li> <li>• 1/100</li> <li>• 1/1000</li> <li>• 1/10000</li> <li>• 1/100000</li> <li>• 1/1000000</li> <li>• 10</li> <li>• 100</li> <li>• 1000</li> <li>• 10000</li> <li>• 100000</li> <li>• 1000000</li> </ul> | No scaling | Optional scaling factor for IEC101/IEC104 communication.<br>Values from 1/10 to 1/1,000,000 apply a division to the measurement.<br>Values from 10 to 1,000,000 apply a multiplication to the measurement. |
| Active energy scaling coef.     |  |            |  |
| Reactive energy scaling coef.   |  |            |  |
| Active power scaling coef.      |  |            |  |
| Reactive power scaling coef.    |  |            |  |
| Apparent power scaling coef.    |  |            |  |
| Power factor scaling coef.      |  |            |  |
| Frequency scaling coef.         |  |            |  |
| Current scaling coef.           |  |            |  |
| Residual current scaling coef.  |  |            |  |
| Voltage scaling coef.           |  |            |  |
| Residual voltage scaling coef.  |  |            |  |
| Angle measurement scaling coef. |  |            |  |
| mA scaling coef.                |  |            |  |

## IEC101/104 deadband settings

Table. 5.3.4 - 387. Analog change deadband settings.

| Name                     | Range            | Step    | Default | Description   |
|--------------------------|------------------|---------|---------|---|
| General deadband         | 0.1...10.0%      | 0.1%    | 2%      | Determines the general data reporting deadband settings.              |
| Active energy deadband   | 0.1...1000.0kWh  | 0.1kWh  | 2kWh    | Determines the data reporting deadband settings for this measurement. |
| Reactive energy deadband | 0.1...1000.0kVar | 0.1kVar | 2kVar   |   |
| Active power deadband    | 0.1...1000.0kW   | 0.1kW   | 2kW     |   |

| Name                       | Range            | Step    | Default | Description |
|----------------------------|------------------|---------|---------|-------------|
| Reactive power deadband    | 0.1...1000.0kVar | 0.1kVar | 2kVar   |             |
| Apparent power deadband    | 0.1...1000.0kVA  | 0.1kVA  | 2kVA    |             |
| Power factor deadband      | 0.01...0.99      | 0.01    | 0.05    |             |
| Frequency deadband         | 0.01...1.00Hz    | 0.01Hz  | 0.1Hz   |             |
| Current deadband           | 0.01...50.00A    | 0.01A   | 5A      |             |
| Residual current deadband  | 0.01...50.00A    | 0.01A   | 0.2A    |             |
| Voltage deadband           | 0.01...5000.00V  | 0.01V   | 200V    |             |
| Residual voltage deadband  | 0.01...5000.00V  | 0.01V   | 200V    |             |
| Angle measurement deadband | 0.1...5.0deg     | 0.1deg  | 1deg    |             |
| mA measurement deadband    | 0.01...5.00 mA   | 0.01 mA | 0.10 mA |             |
| Integration time           | 0...10 000ms     | 1ms     | -       |             |

### 5.3.5 SPA

The device can act as a SPA slave. SPA can be selected as the communication protocol for the RS-485 port (Serial COM1). When the device has a serial option card, the SPA protocol can also be selected as the communication protocol for the serial fiber (Serial COM2) ports or RS-232 (Serial COM3) port. Please refer to the chapter "[Construction and installation](#)" in the device manual to see the connections for these modules.

The data transfer rate of SPA is 9600 bps, but it can also be set to 19 200 bps or 38 400 bps. As a slave the device sends data on demand or by sequenced polling. The available data can be measurements, circuit breaker states, function starts, function trips, etc. The full SPA signal map can be found in *AQtivate (Tools → SPA map)*.

The SPA event addresses can be found at *Tools → Events and logs → Event list*.

The user can enable the SPA protocol at *Communication → Connections*.

Table. 5.3.5 - 388. SPA setting parameters.

| Name          | Range   | Description  |
|---------------|---|--|
| SPA address   | 1...899   | SPA slave address.   |
| UTC time sync | <ul style="list-style-type: none"> <li>• Disabled</li> <li>• Enabled</li> </ul> | Determines if UTC time is used when synchronizing time. When disabled it is assumed time synchronization uses local time. If enabled it is assumed that UTC time is used. When UTC time is used the timezone must be set at <i>Commands</i> → <i>Set time zone</i> . |



**NOTICE!**

To access SPA map and event list, an .aqc configuration file should be downloaded from the device.

### 5.3.6 DNP3

DNP3 is a protocol standard which is controlled by the DNP Users Group ([www.dnp.org](http://www.dnp.org)). The implementation of a DNP3 slave is compliant with the DNP3 subset (level) 2, but it also contains some functionalities of the higher levels. For detailed information please refer to the DNP3 Device Profile document (<https://www.arcteq.com/documents-and-software/> → AQ-200 series → Resources).

The user can enable the DNP3 TCP protocol at *Communication* → *Protocols* → *DNP3*. The user can enable the DNP3 serial protocol at *Communication* → *Connections*.

#### General settings

The following table describes the DNP3 setting parameters.

Table. 5.3.6 - 389. Settings.

| Name                | Range  | Step | Default  | Description  |
|---------------------|--|------|----------|--|
| Enable DNP3 TCP     | <ul style="list-style-type: none"> <li>• Disabled</li> <li>• Enabled</li> </ul>                          | -    | Disabled | Enables and disables the DNP3 TCP communication protocol when the Ethernet port is used for DNP3. If a serial port is used, the DNP3 protocol can be enabled from <i>Communication</i> → <i>DNP3</i> . |
| IP port             | 0...65 535   | 1    | 20 000   | Defines the IP port used by the protocol.  |
| Ethernet port       | <ul style="list-style-type: none"> <li>• All</li> <li>• COM A</li> <li>• Double Ethernet card</li> </ul> | -    | All      | Defines which ethernet ports are available for Modbus connection. Visible if any double ethernet option card is installed in the device.   |
| Slave address       | 1...65 519   | 1    | 1        | Defines the DNP3 slave address of the unit.  |
| Master address      | 1...65 534   | 1    | 2        | Defines the address for the allowed master.  |
| Link layer time-out | 0...60 000ms   | 1ms  | 0ms      | Defines the length of the time-out for the link layer.   |
| Link layer retries  | 1...20   | 1    | 1        | Defines the number of retries for the link layer.  |

| Name                              | Range                | Step | Default | Description  |
|-----------------------------------|----------------------|------|---------|--|
| Diagnostic - Error counter        | $0 \dots 2^{32} - 1$ | 1    | -       | Counts the total number of errors in received and sent messages. |
| Diagnostic - Transmitted messages | $0 \dots 2^{32} - 1$ | 1    | -       | Counts the total number of transmitted messages.                 |
| Diagnostic - Received messages    | $0 \dots 2^{32} - 1$ | 1    | -       | Counts the total number of received messages.                    |

## Default variations

Table. 5.3.6 - 390. Default variations.

| Name                             | Range  | Default | Description   |
|----------------------------------|--|---------|---|
| Group 1 variation (BI)           | <ul style="list-style-type: none"> <li>Var 1</li> <li>Var 2</li> </ul>   | Var 1   | Selects the variation of the binary signal.         |
| Group 2 variation (BI change)    | <ul style="list-style-type: none"> <li>Var 1</li> <li>Var 2</li> </ul>   | Var 2   | Selects the variation of the binary signal change.  |
| Group 3 variation (DBI)          | <ul style="list-style-type: none"> <li>Var 1</li> <li>Var 2</li> </ul>   | Var 1   | Selects the variation of the double point signal.   |
| Group 4 variation (DBI change)   | <ul style="list-style-type: none"> <li>Var 1</li> <li>Var 2</li> </ul>   | Var 2   | Selects the variation of the double point signal.   |
| Group 20 variation (CNTR)        | <ul style="list-style-type: none"> <li>Var 1</li> <li>Var 2</li> <li>Var 5</li> <li>Var 6</li> </ul>                               | Var 1   | Selects the variation of the control signal.        |
| Group 22 variation (CNTR change) | <ul style="list-style-type: none"> <li>Var 1</li> <li>Var 2</li> <li>Var 5</li> <li>Var 6</li> </ul>                               | Var 5   | Selects the variation of the control signal change. |
| Group 30 variation (AI)          | <ul style="list-style-type: none"> <li>Var 1</li> <li>Var 2</li> <li>Var 3</li> <li>Var 4</li> <li>Var 5</li> </ul>                | Var 5   | Selects the variation of the analog signal.         |
| Group 32 variation (AI change)   | <ul style="list-style-type: none"> <li>Var 1</li> <li>Var 2</li> <li>Var 3</li> <li>Var 4</li> <li>Var 5</li> <li>Var 7</li> </ul> | Var 5   | Selects the variation of the analog signal change.  |

## DNP3 measurement scaling coefficients

Table. 5.3.6 - 391. Measurement scaling coefficient settings.

| Name                            | Range  | Default    | Description  |
|---------------------------------|--|------------|--|
| General scaling coef.           | <ul style="list-style-type: none"> <li>• No scaling</li> <li>• 1/10</li> <li>• 1/100</li> <li>• 1/1000</li> <li>• 1/10000</li> <li>• 1/100000</li> <li>• 1/1000000</li> <li>• 10</li> <li>• 100</li> <li>• 1000</li> <li>• 10000</li> <li>• 100000</li> <li>• 1000000</li> </ul> | No scaling | Optional scaling factor for SPA communication. Values from 1/10 to 1/1,000,000 apply a division to the measurement. Values from 10 to 1,000,000 apply a multiplication to the measurement. |
| Active energy scaling coef.     |  |            |  |
| Reactive energy scaling coef.   |  |            |  |
| Active power scaling coef.      |  |            |  |
| Reactive power scaling coef.    |  |            |  |
| Apparent power scaling coef.    |  |            |  |
| Power factor scaling coef.      |  |            |  |
| Frequency scaling coef.         |  |            |  |
| Current scaling coef.           |  |            |  |
| Residual current scaling coef.  |  |            |  |
| Voltage scaling coef.           |  |            |  |
| Residual voltage scaling coef.  |  |            |  |
| Angle measurement scaling coef. |  |            |  |
| mA scaling coef.                |  |            |  |

## DNP3 deadband settings

Table. 5.3.6 - 392. Analog change deadband settings.

| Name                     | Range            | Step    | Default | Description   |
|--------------------------|------------------|---------|---------|---|
| General deadband         | 0.1...10.0%      | 0.1%    | 2%      | Determines the general data reporting deadband settings.              |
| Active energy deadband   | 0.1...1000.0kWh  | 0.1kWh  | 2kWh    | Determines the data reporting deadband settings for this measurement. |
| Reactive energy deadband | 0.1...1000.0kVar | 0.1kVar | 2kVar   |   |
| Active power deadband    | 0.1...1000.0kW   | 0.1kW   | 2kW     |   |

| Name                       | Range            | Step    | Default | Description  |
|----------------------------|------------------|---------|---------|--|
| Reactive power deadband    | 0.1...1000.0kVar | 0.1kVar | 2kVar   |  |
| Apparent power deadband    | 0.1...1000.0kVA  | 0.1kVA  | 2kVA    |  |
| Power factor deadband      | 0.01...0.99      | 0.01    | 0.05    |  |
| Frequency deadband         | 0.01...1.00Hz    | 0.01Hz  | 0.1Hz   |  |
| Current deadband           | 0.01...50.00A    | 0.01A   | 5A      |  |
| Residual current deadband  | 0.01...50.00A    | 0.01A   | 0.2A    |  |
| Voltage deadband           | 0.01...5000.00V  | 0.01V   | 200V    |  |
| Residual voltage deadband  | 0.01...5000.00V  | 0.01V   | 200V    |  |
| Angle measurement deadband | 0.1...5.0deg     | 0.1deg  | 1deg    |  |
| mA deadband                | 0.01...5.00 mA   | 0.01 mA | 0.10 mA |  |
| Integration time           | 0...10 000ms     | 1ms     | 0ms     | Determines the integration time of the protocol. If this parameter is set to "0 ms", no integration time is in use. See chapter " <a href="#">Integration time</a> " for more information. |

### 5.3.7 Modbus I/O

The Modbus I/O protocol can be selected to communicate on the available serial ports. The Modbus I/O is actually a Modbus/RTU master implementation that is dedicated to communicating with serial Modbus/RTU slaves such as RTD input modules. Up to three (3) Modbus/RTU slaves can be connected to the same bus polled by the Modbus I/O implementation. These are named I/O Module A, I/O Module B and I/O Module C. Each of the modules can be configured using parameters in the following two tables.

Table. 5.3.7 - 393. Module settings.

| Name                 | Range   | Description   |
|----------------------|---|---|
| I/O module X address | 0...247   | Defines the Modbus unit address for the selected I/O Module (A, B, or C). If this setting is set to "0", the selected module is not in use. |
| Module x type        | <ul style="list-style-type: none"> <li>ADAM-4018+</li> <li>ADAM-4015</li> </ul> | Selects the module type.  |

| Name            | Range                           | Description  |
|-----------------|---------------------------------|--|
| Channels in use | Channel 0...Channel 7 (or None) | Selects the number of channels to be used by the module. |

Table. 5.3.7 - 394. Channel settings.

| Name              | Range  | Step | Default  | Description  |
|-------------------|--|------|----------|--|
| Thermocouple type | <ul style="list-style-type: none"> <li>• +/- 20mA</li> <li>• 4...20mA</li> <li>• Type J</li> <li>• Type K</li> <li>• Type T</li> <li>• Type E</li> <li>• Type R</li> <li>• Type S</li> </ul> | -    | 4...20mA | Selects the thermocouple or the mA input connected to the I/O module.<br>Types J, K, T and E are nickel-alloy thermocouples, while Types R and S are platinum/rhodium-alloy thermocouples. |
| Input value       | -101.0...2000.0  | 0.1  | -        | Displays the input value of the selected channel.  |
| Input status      | <ul style="list-style-type: none"> <li>• Invalid</li> <li>• OK</li> </ul>  | -    | -        | Displays the input status of the selected channel.   |

### 5.3.8 OPCUA

Table. 5.3.8 - 395. OPCUA settings.

| Name                     | Range   | Step | Default  | Description  |
|--------------------------|---|------|----------|--|
| OPCUA mode               | <ul style="list-style-type: none"> <li>• Disabled</li> <li>• Enabled</li> </ul> | -    | Disabled | Enables or disables the OPCUA protocol.  |
| OPCUA reconfigure        | <ul style="list-style-type: none"> <li>• -</li> <li>• Reconfigure</li> </ul>    | -    | -        | Reconfigures the OPCUA and takes the settings configured in <i>Tools</i> → <i>Communication</i> → <i>OPCUA</i> into use. |
| OPCUA Flat struct enable | <ul style="list-style-type: none"> <li>• Disabled</li> <li>• Enabled</li> </ul> | -    | Disabled |  |

### 5.3.9 Integration time

When integration time is not used, measurement values are updated only when the change exceeds the configured deadband. If the deadband is set too low, measurements may be reported too frequently, creating unnecessary traffic. If the deadband is configured too high, the measurement may almost never update. When integration time is used, large changes are still reported quickly, but smaller changes are accumulated over time and eventually reported even if the deadband is not very sensitive.

With integration time enabled, the following parameters determine when a measurement is reported:

- deadband setting of the measurement
- integration time setting
- latest reported measurement value
- measured value.

An integrated value is calculated over time using these parameters. Once this integrated value exceeds the deadband, a new measurement update is sent.

Figure. 5.3.9 - 194. Integration time formula.

$$\text{Integrated value} = |\text{Measured value} - \text{Latest reported value}| * \left( \frac{t}{\text{Integration time}} \right)$$

Figure. 5.3.9 - 195. Example graph showing how integration time affects measurement reporting. Small changes take longer to increase the integrated value over the deadband setting (blue area). Big changes meet the deadband criteria faster (red area).

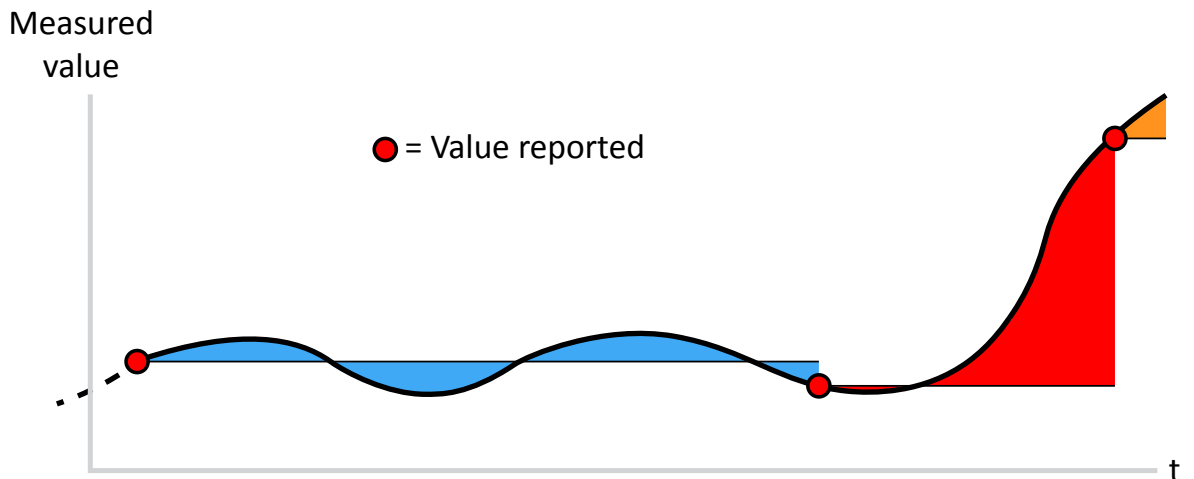

The time it takes for a value to be updated with the configured settings can be roughly estimated with the following formula:

Figure. 5.3.9 - 196. Measurement reporting delay when integration time is used.

$$t = \frac{\text{Deadband setting} * \text{Integration time setting}}{|\text{Measured value} - \text{Latest reported value}|}$$

If the latest reported value was 5.00 A and the measurement rises up to 6.00 A and stays stable, and the deadband setting for current is 2 A and the integration time setting is 1 s, we get the following result:

Figure. 5.3.9 - 197. Calculation example for estimating reporting time when integration time is in use.

$$t = \frac{2A * 1s}{|6A - 5A|} = 2s$$

## 5.4 Analog fault registers

At *Communication* → *General I/O* → *Analog fault registers* the user can set up to twelve (12) channels to record the measured value when a protection function starts or trips. These values can be read in two ways: locally from this same menu, or through a communication protocol if one is in use.

The following table presents the setting parameters available for the 12 channels.

Table. 5.4 - 396. Fault register settings.

| Name                  | Range   | Step | Default     | Description  |
|-----------------------|---|------|-------------|--|
| Select record source  | Not in use<br>I>, I>>, I>>>, I>>>> (IL1, IL2, IL3)<br>Id>, Id>>, Id>>>, Id>>>> (IL1, IL2, IL3)<br>IO>, IO>>, IO>>>, IO>>>> (IO)<br>IOd>, IOd>>, IOd>>>, IOd>>>> (IO)<br>FLX (Fault locator) | -    | Not in use  | Selects the protection function and its stage to be used as the source for the fault register recording.<br>The user can choose between non-directional overcurrent, directional overcurrent, non-directional earth fault, directional earth fault, and fault locator functions. |
| Select record trigger | <ul style="list-style-type: none"> <li>• TRIP signal</li> <li>• START signal</li> <li>• START and TRIP signals</li> </ul>   | -    | TRIP signal | Selects what triggers the fault register recording: the selected function's TRIP signal, its START signal, or either one.  |
| Recorded fault value  | - 1000<br>000.00...1<br>000 000.00  | 0.01 | -           | Displays the recorded measurement value at the time of the selected fault register trigger.  |

## 5.5 Modbus Gateway

Figure. 5.5 - 198. Example setup of Modbus Gateway application.

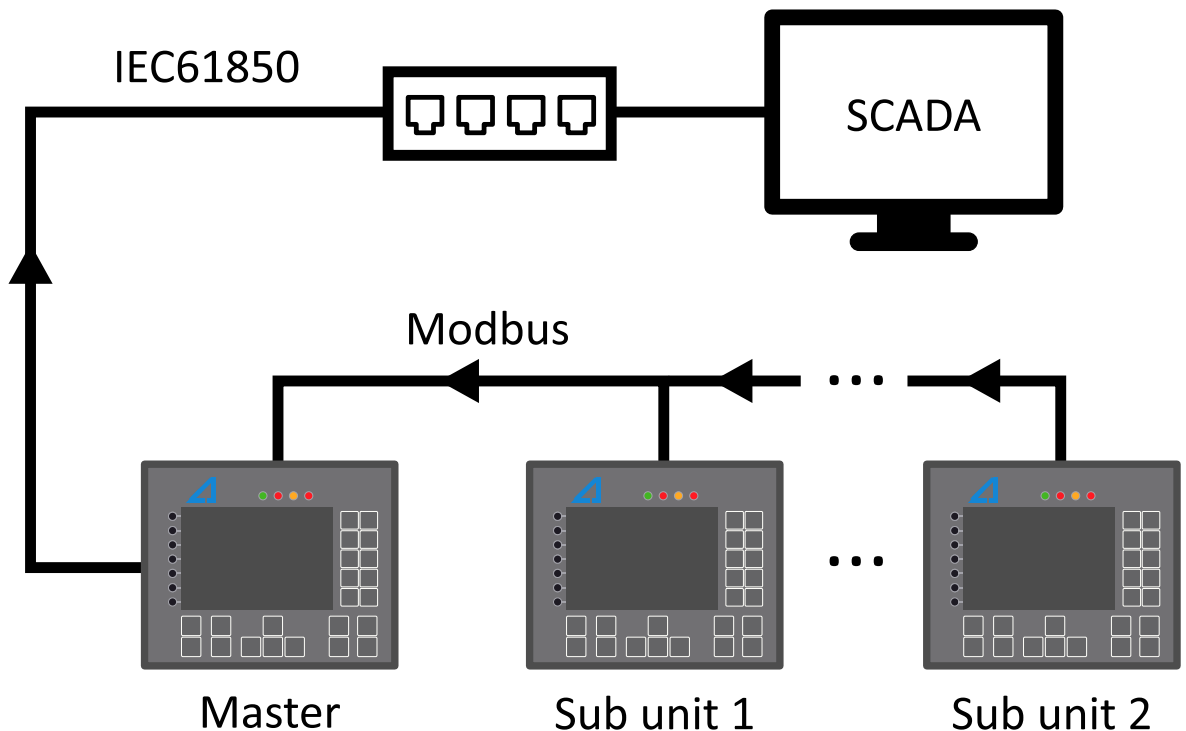

The device can be setup as a Modbus Gateway (i.e. master). Modbus Gateway device can import messages (measurements, status signals etc.) from external Arcteq and third-party devices. RS-485 serial communication port. Up to 32 sub units can be connected to a master unit. These messages can then be used for controlling logic in the master device, display the status in user created mimic. Binary signals can be reported forward to SCADA with IEC61850, IEC101, IEC103, IEC104, Modbus, DNP3 or SPA.

Modbus Gateway and its basic settings can be found from *Communication* → *Modbus Gateway*. General settings-menu displays the health of connection to each sub unit.

Table. 5.5 - 397. General settings

| Name                              | Range  | Description   |
|-----------------------------------|--|---|
| Modbus Gateway mode               | <ul style="list-style-type: none"> <li>Disabled (Default)</li> <li>Enabled</li> </ul>  | Enables or disables Modbus Gateway.   |
| Modbus Gateway reconfigure        | -<br>Reconfigure   | Setting this parameter to "Reconfigure" takes new settings into use. Parameter returns back to "-" automatically. |
| Quality of Modbus Sub unit 1...32 | <ul style="list-style-type: none"> <li>OK</li> <li>Old data</li> <li>Data questionable</li> <li>Modbus error</li> <li>Send fail</li> <li>Receive fail</li> </ul> | Quality of each connected sub unit.   |

## Imported signals

Modbus Gateway supports importing of measurements, bits, double bits, counters and integer signals. Up to 128 signals can be imported of each signal type with the exception of double bits (32).

Table. 5.5 - 398. Imported signals

| Name                          | Range                    |
|-------------------------------|--------------------------|
| Imported measurement 1-128    | -3.4E+38...3.4E+38       |
| Imported bit signal 1-128     | 0...1                    |
| Imported double bit data 1-32 | 0...3                    |
| Imported counter data 1-128   | 0...4294967295           |
| Imported integer signal 1-128 | -2147483648...2147483647 |

To assign the signals use Modbus Gateway editor (*Tools* → *Communication* → *Modbus Gateway*). Detailed description of this tool can be found in *AQtivate Instruction manual* (<https://www.arcteq.com/documents-and-software/>).

All imported signals can be given a description. The description will be displayed in most of menus with the signal (logic editor, matrix, block settings etc.).

Table. 5.5 - 399. Imported signal user description.

| Name                         | Range             | Default        | Description   |
|------------------------------|-------------------|----------------|---|
| Describe measurement x       | 1...31 characters | Acq. Meas x    | User settable description for the signal. This description is used in several menu types for easier identification. |
| Describe bit signal x        |                   | Acq. Bit x     |   |
| Describe double bit signal x |                   | Acq. Binary x  |   |
| Describe counter signal x    |                   | Acq. Counter x |   |
| Describe integer signal x    |                   | Acq. Integer x |   |

## Events

The Modbus Gateway generates events the status changes in imported bits and double bits. The user can select which event messages are stored in the main event buffer: ON, OFF, or both.

Table. 5.5 - 400. Event messages

| Event block name | Event names   |
|------------------|---|
| MGWB1            | Bit 1...Bit 32 (ON, OFF)  |
| MGWB2            | Bit 33...Bit 64 (ON, OFF)                                       |
| MGWB3            | Bit 65...Bit 96 (ON, OFF)                                       |
| MGWB4            | Bit 97...Bit 128 (ON, OFF)                                      |
| MGWD1            | Double Bit 1... Double bit 16 (ON/ON, OFF/OFF, ON/OFF, OFF/ON)  |
| MGWD2            | Double Bit 17... Double bit 32 (ON/ON, OFF/OFF, ON/OFF, OFF/ON) |

## 6 Connections and application examples

### 6.1 Connections of AQ-T257

Figure. 6.1 - 199. AQ-T257A application example with function block diagram.

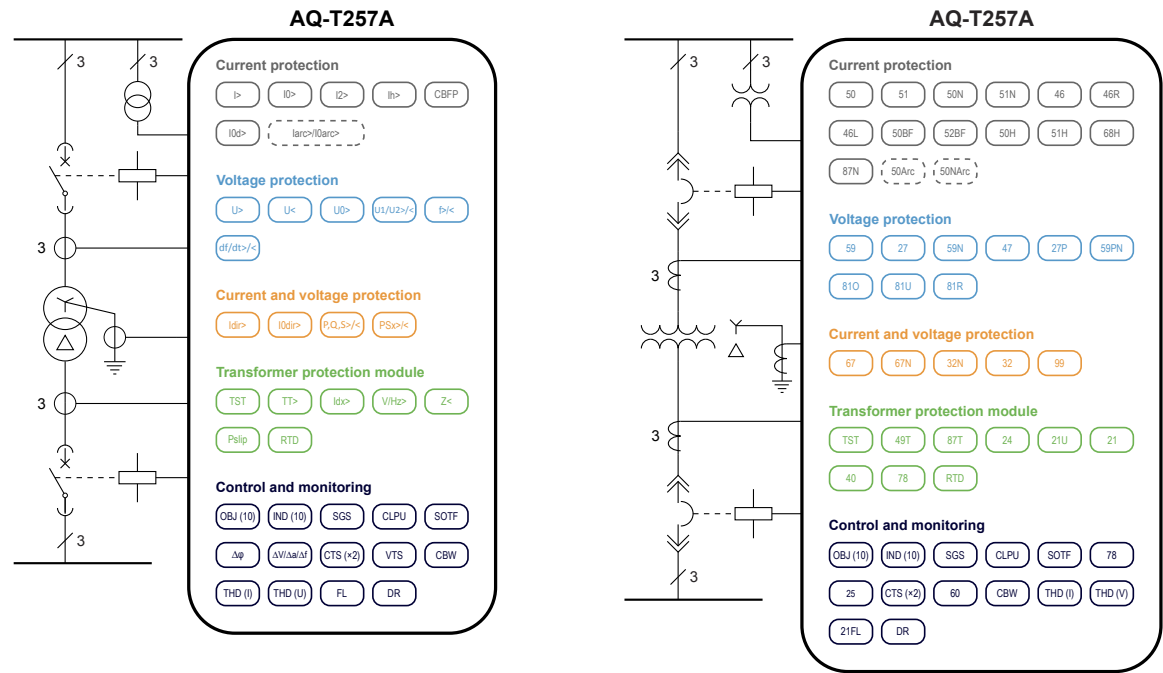
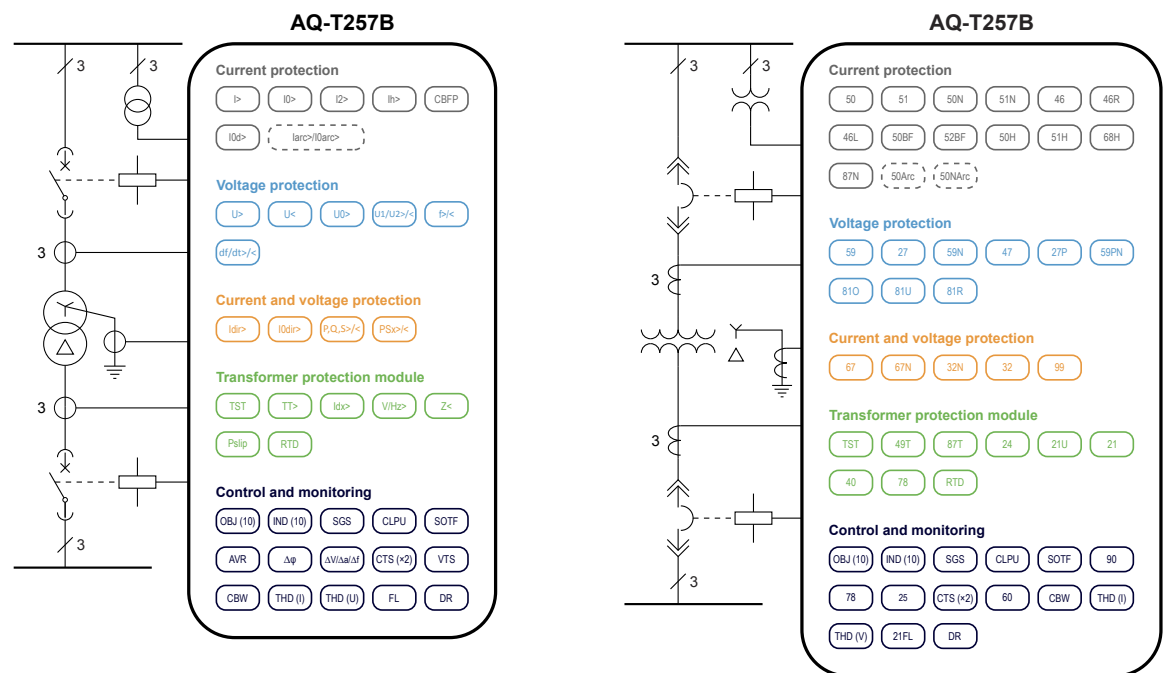

Figure. 6.1 - 200. AQ-T257B application example with function block diagram.



## 6.2 Application example and its connections

This chapter presents an application example for the two-winding transformer differential device. The example is a regular differential scheme with restricted earth fault protection on the high-voltage side.

As can be seen in the image below, the example application has two current transformers. The first (upper) CT has the three phase current as well as the residual current (I01) connected. The second CT also has the three phase currents but no residual current connected. Additionally, since three line-to-neutral voltages are connected, this application's voltage transformer uses the voltage measurement mode "3LN".

Figure. 6.2 - 201. Application example and its connections.

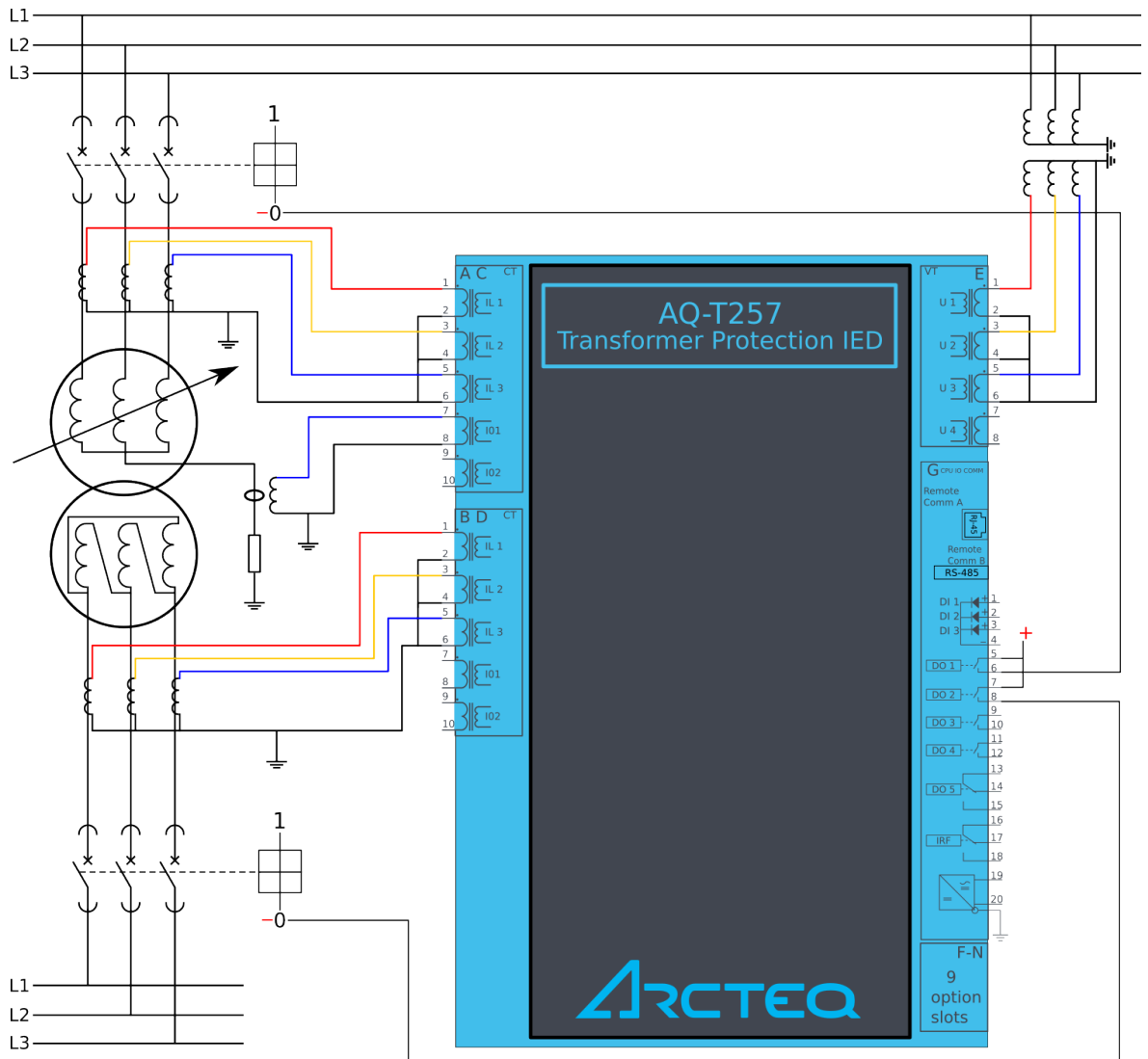

## 7 Construction and installation

### 7.1 Construction

AQ-X257 is a member of the modular and scalable AQ-200 series, and it includes nine (9) configurable and modular add-on card slots. As a standard configuration the device includes the CPU module (which consists of the CPU, a number of inputs and outputs, and the power supply) as well as two separate current measurement modules and one separate voltage measurement module.

The images below present the modules of both the non-optioned model (AQ-X257-XXXXXXX-AAAAAAAAA) and the fully optioned model (AQ-X257-XXXXXXX-BBBCCCCJ).

Figure. 7.1 - 202. Modular construction of AQ-X257-XXXXXXX-AAAAAAAAA

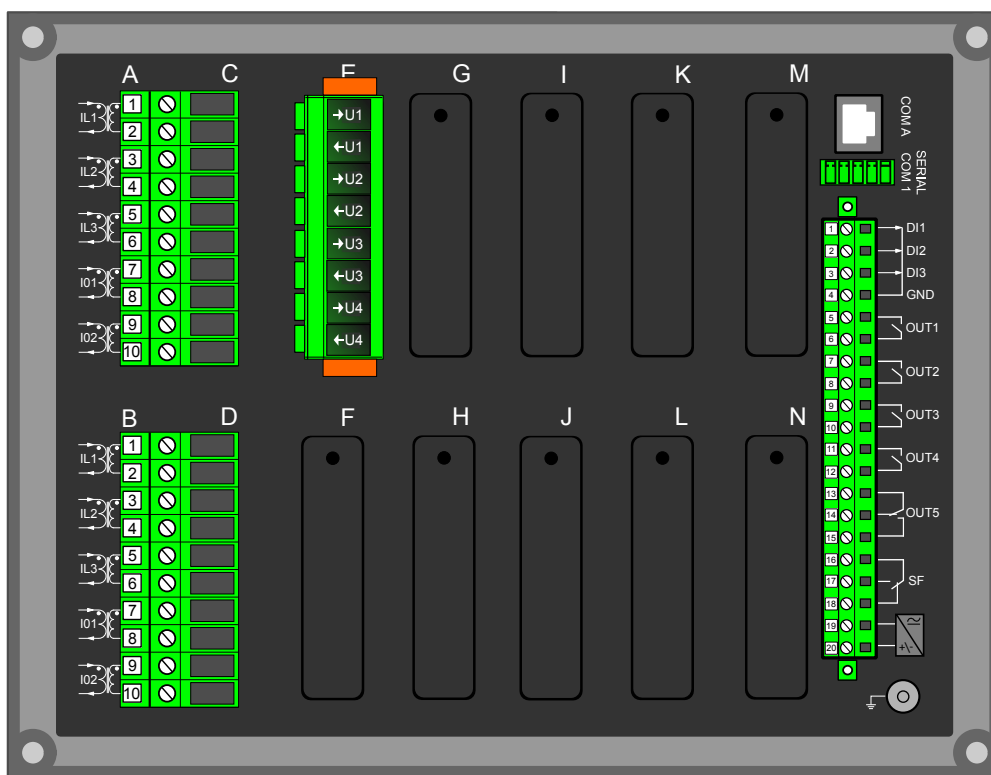
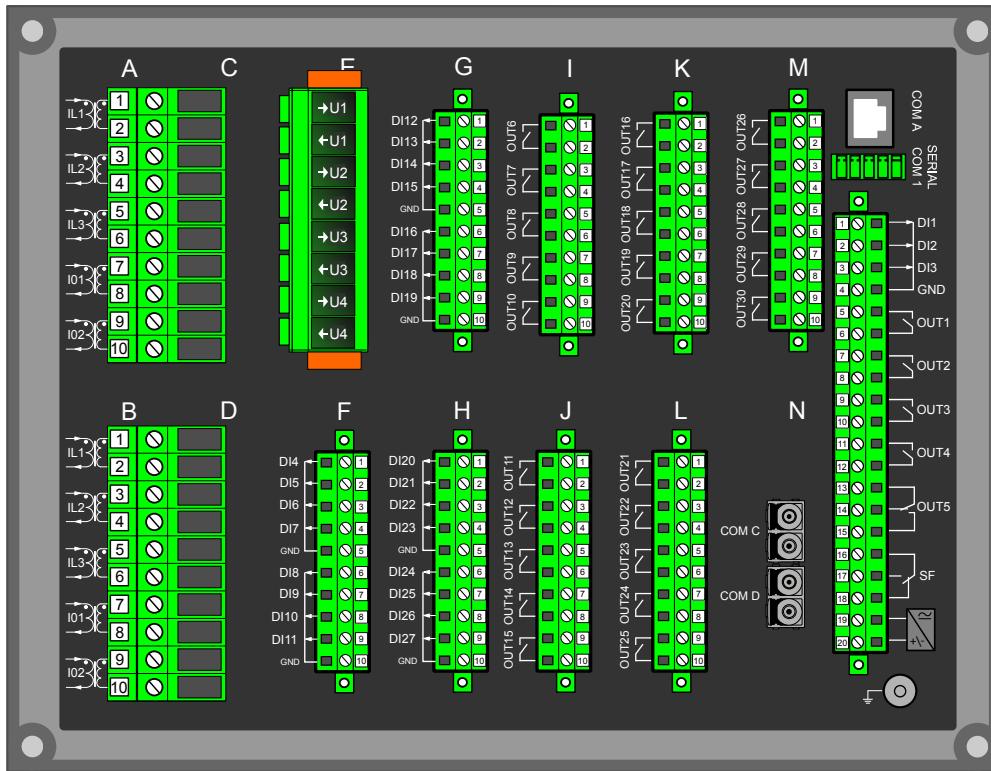

Figure. 7.1 - 203. Modular construction of AQ-X257-XXXXXXX-BBBCCCCCJ



The modular structure of AQ-X257 allows for scalable solutions for different application requirements. In non-standard configurations Slots from F to N accept all available add-on modules, such as digital I/O modules, integrated arc protection and other special modules. The only difference between the slots affecting device scalability is that Slots M and N both also support communication options.

Start-up scan searches for modules according to their type designation code. If the module content is not what the device expects, the device issues a hardware configuration error message. In field upgrades, therefore, add-on modules must be ordered from Arcteq Relays Ltd. or its representative who can then provide the module with its corresponding unlocking code to allow the device to operate correctly once the hardware configuration has been upgraded.

When an I/O module is inserted into the device, the module location affects the naming of the I/O. The I/O scanning order in the start-up sequence is as follows: the CPU module I/O, Slot F, Slot G, Slot H and so on. This means that the digital input channels DI1, DI2 and DI3 as well as the digital output channels OUT1, OUT2, OUT3, OUT4 and OUT5 are always located in the CPU module. If additional I/O cards are installed, their location and card type affect the I/O naming.

The figure below presents the start-up hardware scan order of the device as well as the I/O naming principles.

Figure. 7.1 - 204. AQ-X257 hardware scanning and I/O naming principles.

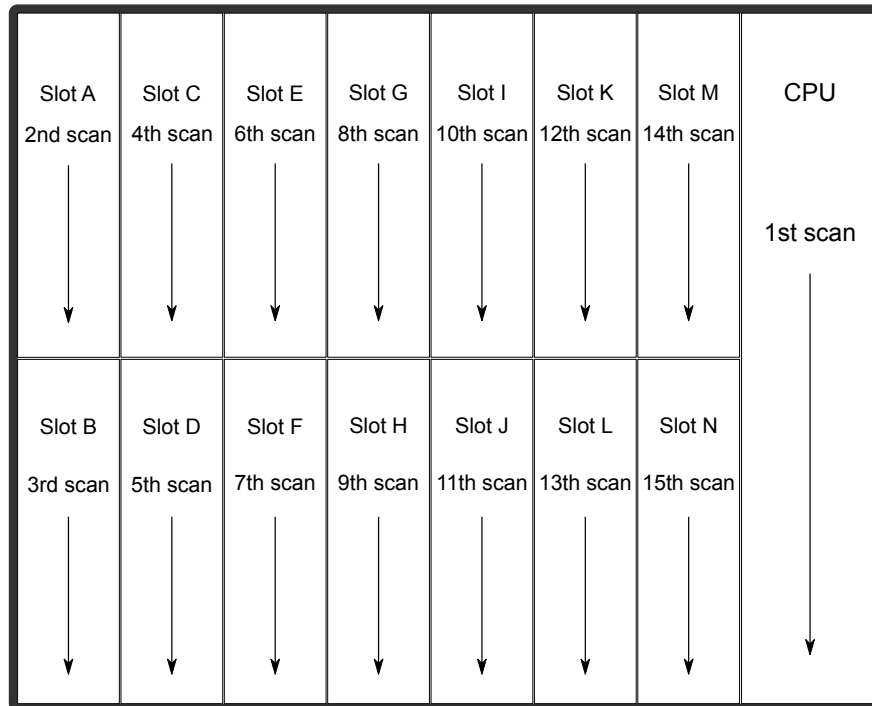

1. Scan  
The start-up system; detects and self-tests the CPU module, voltages, communication and the I/O; finds and assigns "DI1", "DI2", "DI3", "OUT1", "OUT2", "OUT3", "OUT4" and "OUT5".
2. Scan  
Scans Slot A, which should always remain empty in AQ-X257 devices. If it is not empty, the device issues an alarm.
3. Scan  
Scans Slot B, which should always remain empty in AQ-X257 devices. If it is not empty, the device issues an alarm.
4. Scan  
Scans Slot C and finds the five channels of the CT module (fixed for AQ-X257). If the CTM is not found, the device issues an alarm.
5. Scan  
Scans Slot D and finds the five channels of the CT module (fixed for AQ-X257). If the CTM is not found, the device issues an alarm.
6. Scan  
Scans Slot E and finds the four channels of the VT module (fixed for AQ-257). If the VTM is not found, the device issues an alarm.
7. Scan  
Scans Slot F, and moves to the next slot if Slot F is empty. If the scan finds an 8DI module (that is, a module with eight digital inputs), it reserves the designations "DI4", "DI5", "DI6", "DI7", "DI8", "DI9", "DI10" and "DI11" to this slot. If the scan finds a DO5 module (that is, a module with five digital outputs), it reserves the designations "OUT6", "OUT7", "OUT8", "OUT9" and "OUT10" to this slot. The I/O is then added if the type designation code (e.g. AQ-P215-PH0AAAA-BBC) matches with the existing modules in the device. If the code and the modules do not match, the device issues an alarm. An alarm is also issued if the device expects to find a module here but does not find one.

8. Scan

Scans Slot G, and moves to the next slot if Slot G is empty. If the scan finds an 8DI module, it reserves the designations "DI4", "DI5", "DI6", "DI7", "DI8", "DI9", "DI10" and "DI11" to this slot. If Slot F also has an 8DI module (and therefore has already reserved these designations), the device reserves the designations "DI12", "DI13", "DI14", "DI15", "DI16", "DI17", "DI18" and "DI19" to this slot. If the scan finds a 5DO module, it reserves the designations "OUT6", "OUT7", "OUT8", "OUT9" and "OUT10" to this slot. Again, if Slot F also has a 5DO and has therefore already reserved these designations, the device reserves the designations "OUT11", "OUT12", "OUT13", "OUT14" and "OUT15" to this slot.

9. – 15. Scan

A similar operation to Scan 8 (checks which designations have been reserved by modules in previous slots and numbers the new ones accordingly).

With AQ-X257-XXXXXXX-BBBCCCCCJ (the first image pair, on the right) has a total of 27 digital input channels available: three (DI1...DI3) in the CPU module, and the rest in Slots F...H in groups of eight. It also has a total of 30 digital output channels available: five (DO1...DO5) in the CPU module, and the rest in Slots I...M in groups of five. Slot N has a double (LC) fiber Ethernet communication option card installed.

## 7.2 CPU module

Figure. 7.2 - 205. CPU module can be equipped with standard screw terminals or spring cage terminals for connection.

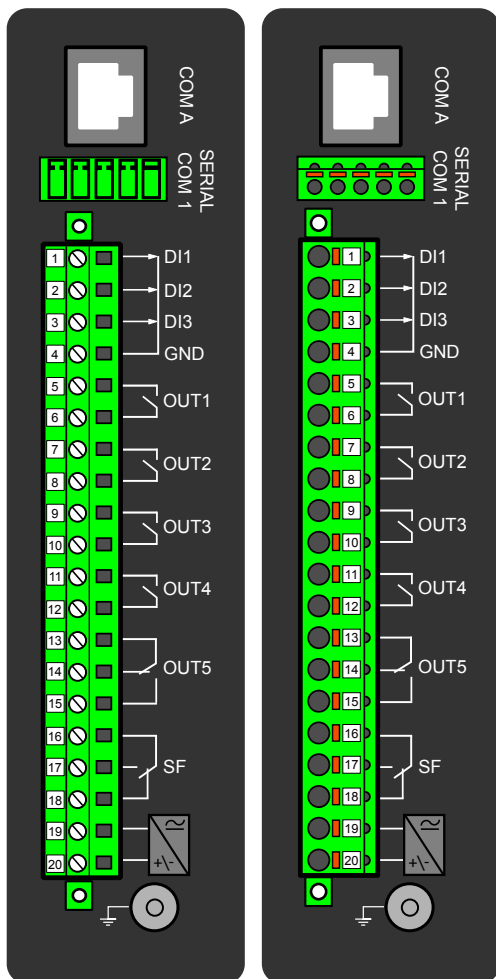

| Connector   | Description  |
|-------------|--|
| COM A       | Communication port A, or the RJ-45 port. Used for the setting tool connection and for SCADA communication.   |
| COM B       | Communication port B, or the RS-485 port. Used for SCADA communication. The pins have the following designations: <ul style="list-style-type: none"> <li>• Pin 1 = DATA +</li> <li>• Pin 2 = DATA –</li> <li>• Pin 3 = GND</li> <li>• Pins 4 &amp; 5 = Terminator resistor enabled by shorting.</li> </ul> |
| X1-1        | Digital input 1, nominal threshold voltage 24 V, 110 V or 220 V.   |
| X1-2        | Digital input 2, nominal threshold voltage 24 V, 110 V or 220 V.   |
| X1-3        | Digital input 3, nominal threshold voltage 24 V, 110 V or 220 V.   |
| X1-4        | Common GND for digital inputs 1, 2 and 3.  |
| X1-5:6      | Output relay 1, with a normally open (NO) contact.   |
| X1-7:8      | Output relay 2, with a normally open (NO) contact.   |
| X1-9:10     | Output relay 3, with a normally open (NO) contact.   |
| X1-11:12    | Output relay 4, with a normally open (NO) contact.   |
| X1-13:14:15 | Signaling relay 5, with a changeover contact. Not to be used in trip coil control.   |
| X1-16:17:18 | System fault's signaling relay, with a changeover contact. Pins 16 and 17 are closed when the unit has a system fault or is powered OFF. Pins 16 and 18 are closed when the unit is powered ON and there is no system fault.   |
| X1-19:20    | Power supply IN. Either 88...265 VAC/DC (model A; order code "H") or 18...75 DC (model B; order code "L"). <b>Positive side (+) to Pin 20.</b>   |
| GND         | The device's earthing connector.   |

By default, the CPU module (combining the CPU, the I/O and the power supply) includes two standard communication ports and the device's basic digital I/O.

The digital output controls can be set by the user with software. Digital outputs are controlled in 5 ms program cycles. All output contacts are mechanical. The rated voltage of the NO/NC outputs is 250 VAC/DC.

## Digital inputs

The current consumption of the digital inputs is 2 mA when activated. The range of the operating voltage is 24 V/110 V/220 V depending on the ordered hardware. All digital inputs are scanned in 5 ms program cycles.

The settings described in the table below can be found at *Control* → *Device I/O* → *Digital input settings* in the device settings.

Table. 7.2 - 401. Digital input settings.

| Name                 | Range  | Step    | Default  | Description  |
|----------------------|--|---------|----------|--|
| Dlx Polarity         | <ul style="list-style-type: none"> <li>• NO (Normally open)</li> <li>• NC (Normally closed)</li> </ul> | -       | NO       | Selects whether the status of the digital input is 1 or 0 when the input is energized.         |
| Dlx Activation delay | 0.000...1800.000 s   | 0.001 s | 0.000 s  | Defines the delay for the status change from 0 to 1.   |
| Dlx Drop-off time    | 0.000...1800.000 s   | 0.001 s | 0.000 s  | Defines the delay for the status change from 1 to 0.   |
| Dlx AC mode          | <ul style="list-style-type: none"> <li>• Disabled</li> <li>• Enabled</li> </ul>                        | -       | Disabled | Selects whether or not a 30-ms deactivation delay is added to account for alternating current. |

## Digital outputs

The digital output controls can be set by the user with software. Digital outputs are controlled in 5 ms program cycles. All output contacts are mechanical. The rated voltage of the NO/NC outputs is 250 VAC/DC.

Table. 7.2 - 402. Digital output settings.

| Name           | Range  | Description  |
|----------------|--|--|
| Out x Polarity | <ul style="list-style-type: none"> <li>• NO</li> <li>• NC</li> </ul> | <p>Determines the normal status of the output relay.</p> <p>Digital outputs are configured as "normally open" relays by default. Each output can be changed to "normally closed" using the "OUTx Polarity" parameter.</p> <p>Please note that this change is implemented in software only. If the device is powered off, the outputs will revert to an open state and return to the configured polarity once power is restored.</p> <p>If a truly "normally closed" contact is required, use the changeover relay OUT5 available in the CPU module of the device.</p> <p>An NC output signal does not open during a Communication or Protection reset.</p> |

## Digital input and output descriptions

CPU card digital inputs and outputs can be given a description. The user defined description are displayed in most of the menus:

- logic editor
- matrix
- block settings
- event history
- disturbance recordings
- etc.

Table. 7.2 - 403. Digital input and output user description.

| Name                           | Range             | Default | Description  |
|--------------------------------|-------------------|---------|--|
| User editable description DIx  | 1...31 characters | DIx     | Description of the digital input. This description is used in several menu types for easier identification.  |
| User editable description OUTx |                   | OUTx    | Description of the digital output. This description is used in several menu types for easier identification. |

**NOTICE!**

After editing user descriptions the event history will start to use the new description only after resetting the HMI. HMI can be reset from *General* → *Device info* → *HMI restart*.

### Scanning cycle

All digital inputs are scanned in a 5 ms cycle, meaning that the state of an input is updated every 0...5 milliseconds. When an input is used internally in the device (either in setting group change or logic), it takes additional 0...5 milliseconds to operate. Theoretically, therefore, it takes 0...10 milliseconds to change the setting group when a digital input is used for group control or a similar function. In practice, however, the delay is between 2...8 milliseconds about 95 % of the time. When a digital input is connected directly to a digital output (OUT1...OUTx), it takes an additional 5 ms round. Therefore, when a digital input controls a digital output internally, it takes 0...15 milliseconds in theory and 2...13 milliseconds in practice.

**NOTICE!**

The mechanical delay of the relay is not included in these approximations!

## 7.3 Current measurement module

Figure. 7.3 - 206. Module connections with standard and ring lug terminals.

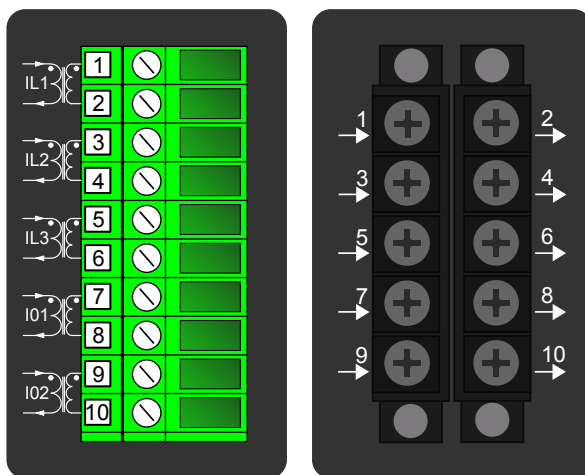

| Connector | Description                                 |
|-----------|---|
| CTM 1-2   | Phase current measurement for phase L1 (A). |
| CTM 3-4   | Phase current measurement for phase L2 (B). |
| CTM 5-6   | Phase current measurement for phase L3 (C). |

| Connector | Description                              |
|-----------|--|
| CTM 7-8   | Coarse residual current measurement I01. |
| CTM 9-10  | Fine residual current measurement I02.   |

A basic current measurement module with five channels includes three-phase current measurement inputs as well as coarse and fine residual current inputs. The CT module is available with either standard or ring lug connectors.

The current measurement module is connected to the secondary side of conventional current transformers (CTs). The nominal current for the phase current inputs is 5 A. The input nominal current can be scaled for secondary currents of 1...10 A. The secondary currents are calibrated to nominal currents of 1 A and 5 A, which provide  $\pm 0.5\%$  inaccuracy when the range is  $0.005...4 \times I_n$ .

The measurement ranges are as follows:

- Phase currents 25 mA...250 A (RMS)
- Coarse residual current 5 mA...150 A (RMS)
- Fine residual current 1 mA...75 A (RMS)

The characteristics of phase current inputs are as follows:

- The angle measurement inaccuracy is less than  $\pm 0.2$  degrees with nominal current.
- The frequency measurement range of the phase current inputs is 6...1800 Hz with standard hardware.
- The sample rate of the signal is 64 samples/cycle when the system frequency ranges from 6 Hz to 75 Hz.

For further details please refer to the "[Current measurement](#)" chapter in the "Technical data" section of this document.

## 7.4 Voltage measurement module

Figure. 7.4 - 207. Voltage measurement module can be equipped with standard screw terminals or spring cage terminals for connection.

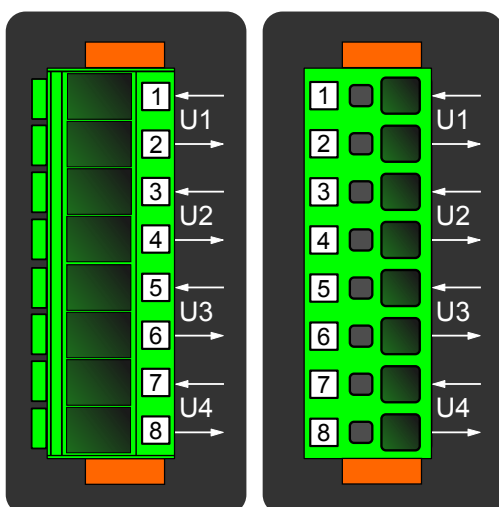

| Connector | Description                                |
|-----------|--|
| VTM 1-2   | Configurable voltage measurement input U1. |

| Connector | Description                                |
|-----------|--|
| VTM 3-4   | Configurable voltage measurement input U2. |
| VTM 5-6   | Configurable voltage measurement input U3. |
| VTM 7-8   | Configurable voltage measurement input U4. |

A basic voltage measurement module with four channels includes four voltage measurement inputs that can be configured freely.

The voltage measurement module is connected to the secondary side of conventional voltage transformers (VTs) or directly to low-voltage systems secured by fuses. The nominal voltage can be set between 100...400 V. Voltages are calibrated in a range of 0...240 V, which provides  $\pm 0.2\%$  inaccuracy in the same range.

The voltage input characteristics are as follows:

- The measurement range is 0.5...480.0 V per channel.
- The angle measurement inaccuracy is less than  $\pm 0.5$  degrees within the nominal range.
- The frequency measurement range of the voltage inputs is 6...1800 Hz with standard hardware.
- The sample rate of the signal is 64 samples/cycle when the system frequency ranges from 6 Hz to 75 Hz.

For further details please refer to the "[Voltage measurement](#)" chapter in the "Technical data" section of this document.

## 7.5 Option cards

### 7.5.1 Digital input module (optional)

Figure. 7.5.1 - 208. Digital input module (DI8) with eight add-on digital inputs. Can be equipped with standard screw terminals or spring cage terminals for connection.

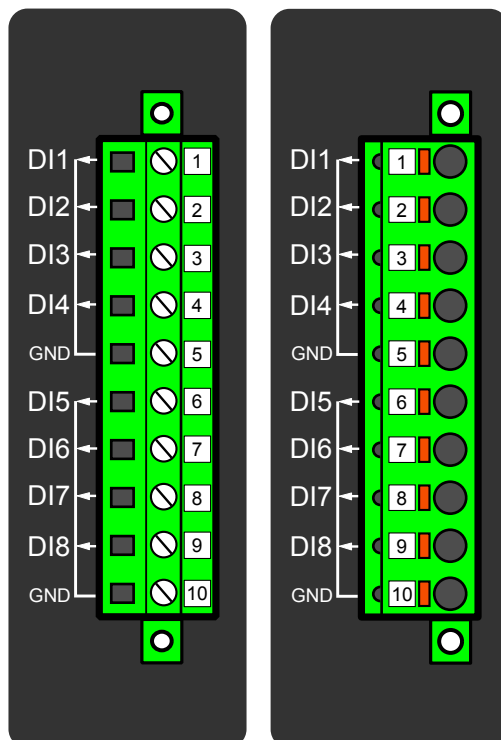

| Connector | Description (x = the number of digital inputs in other modules that precede this one in the configuration) |
|-----------|--|
| X 1       | DIx + 1  |
| X 2       | DIx + 2  |
| X 3       | DIx + 3  |
| X 4       | DIx + 4  |
| X 5       | Common earthing for the first four digital inputs.   |
| X 6       | DIx + 5  |
| X 7       | DIx + 6  |
| X 8       | DIx + 7  |
| X 9       | DIx + 8  |
| X 10      | Common earthing for the other four digital inputs.   |

The DI8 module is an add-on module with eight (8) galvanically isolated digital inputs. This module can be ordered directly to be installed into the device in the factory, or it can be upgraded in the field after the device's original installation when required. The properties of the inputs in this module are the same as those of the inputs in the main processor module. The current consumption of the digital inputs is 2 mA when activated, while the range of the operating voltage is from 0...265 VAC/DC. The activation and release thresholds are set in the software and the resolution is 1 V. All digital inputs are scanned in 5 ms program cycles, and their pick-up and release delays as well as their NO/NC selection can be set with software.

For the naming convention of the digital inputs provided by this module please refer to the chapter titled "[Construction and installation](#)".

For technical details please refer to the chapter titled "[Digital input module](#)" in the "Technical data" section of this document.

The hardware configuration code of this module is "B". For more information, please refer to the "[Ordering information](#)" chapter of this document.

### Setting up the activation and release delays

The settings described in the table below can be found at *Control* → *Device I/O* → *Digital input settings* in the device settings.

Table. 7.5.1 - 404. Digital input settings of DI8 module.

| Name         | Range  | Step | Default | Description  |
|--------------|--|------|---------|--|
| DIx Polarity | <ul style="list-style-type: none"> <li>NO (Normally open)</li> <li>NC (Normally closed)</li> </ul> | -    | NO      | Selects whether the status of the digital input is 1 or 0 when the input is energized. |

| Name                     | Range   | Step    | Default  | Description   |
|--------------------------|---|---------|----------|---|
| Dlx Activation threshold | 16.0...200.0 V  | 0.1 V   | 88 V     | Defines the activation threshold for the digital input. When "NO" is the selected polarity, the measured voltage exceeding this setting activates the input. When "NC" is the selected polarity, the measured voltage exceeding this setting deactivates the input. |
| Dlx Release threshold    | 10.0...200.0 V  | 0.1 V   | 60V      | Defines the release threshold for the digital input. When "NO" is the selected polarity, the measured voltage below this setting deactivates the input. When "NC" is the selected polarity, the measured voltage below this setting activates the input.            |
| Dlx Activation delay     | 0.000...1800.000 s  | 0.001 s | 0.000 s  | Defines the delay when the status changes from 0 to 1. Not visible when DI has been set to AC mode with "Dlx AC mode" parameter.  |
| Dlx Drop-off time        | 0.000...1800.000 s  | 0.001 s | 0.000 s  | Defines the delay when the status changes from 1 to 0.  |
| Dlx AC Mode              | <ul style="list-style-type: none"> <li>Disabled</li> <li>Enabled</li> </ul> | -       | Disabled | Selects whether or not a 30-ms deactivation delay is added to take the alternating current into account. The "Dlx Release threshold" parameter is hidden and forced to 10 % of the set "Dlx Activation threshold" parameter.  |
| Dlx Counter              | $0 \dots 2^{32} - 1$  | 1       | 0        | Displays the number of times the digital input has changed its status from 0 to 1.  |
| Dlx Clear counter        | <ul style="list-style-type: none"> <li>-</li> <li>Clear</li> </ul>          | -       | -        | Resets the Dlx counter value to zero.   |

The user can set the activation threshold individually for each digital input. When the activation and release thresholds have been set properly, they will result in the digital input states to be activated and released reliably. The selection of the normal state between normally open (NO) and normally closed (NC) defines whether or not the digital input is considered activated when the digital input channel is energized.

The diagram below depicts the digital input states when the input channels are energized and de-energized.

Figure. 7.5.1 - 209. Digital input state when energizing and de-energizing the digital input channels.

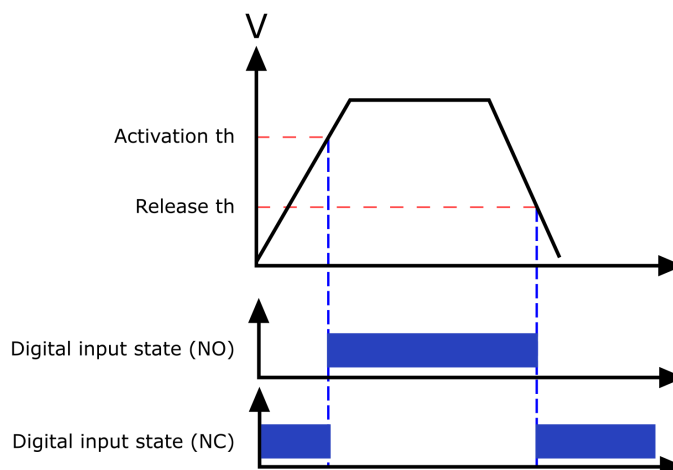

## Digital input descriptions

Option card inputs can be given a description. The user defined description are displayed in most of the menus:

- logic editor
- matrix
- block settings
- event history
- disturbance recordings
- etc.

Table. 7.5.1 - 405. Digital input user description.

| Name                          | Range             | Default | Description   |
|-------------------------------|-------------------|---------|---|
| User editable description Dlx | 1...31 characters | Dlx     | Description of the digital input. This description is used in several menu types for easier identification. |



### NOTICE!

After editing user descriptions the event history will start to use the new description only after resetting the HMI. HMI can be reset from *General* → *Device info* → *HMI restart*.

## Digital input voltage measurements

Digital input option card channels measure voltage on each channel. The measured voltage can be seen at *Control* → *Device IO* → *Digital inputs* → *Digital input voltages*.

Table. 7.5.1 - 406. Digital input channel voltage measurement.

| Name            | Range             | Step    | Description                                     |
|-----------------|-------------------|---------|---|
| Dlx Voltage now | 0.000...275.000 V | 0.001 V | Voltage measurement of a digital input channel. |

## 7.5.2 Digital output module (optional)

Figure. 7.5.2 - 210. Digital output module (DO5) with five add-on digital outputs. Can be equipped with standard screw terminals or spring cage terminals for connection.

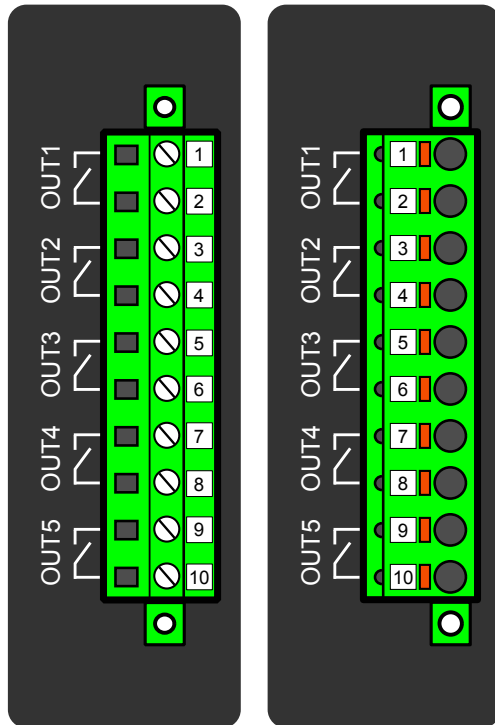

| Connector | Description  |
|-----------|--|
| X 1-2     | OUTx + 1 (1 <sup>st</sup> and 2 <sup>nd</sup> pole NO) |
| X 3-4     | OUTx + 2 (1 <sup>st</sup> and 2 <sup>nd</sup> pole NO) |
| X 5-6     | OUTx + 3 (1 <sup>st</sup> and 2 <sup>nd</sup> pole NO) |
| X 7-8     | OUTx + 4 (1 <sup>st</sup> and 2 <sup>nd</sup> pole NO) |
| X 9-10    | OUTx + 5 (1 <sup>st</sup> and 2 <sup>nd</sup> pole NO) |

The DO5 module is an add-on module with five (5) mechanical type digital outputs. This module can be ordered directly to be installed into the device in the factory, or it can be upgraded in the field after the device's original installation when required. The properties of the outputs in this module are the same as those of the outputs in the main processor module. Output control logic is user configurable. All digital outputs are controlled in 5 ms program cycles. The rated voltage of the outputs is 250 VAC/DC.

For the naming convention of the digital outputs provided by this module please refer to the chapter titled "[Construction and installation](#)".

For technical details please refer to the chapter titled "[Digital output module](#)" in the "Technical data" section of this document.

The hardware configuration code of this module is "C". For more information, please refer to the "[Ordering information](#)" chapter of this document.

## Digital output settings

The parameters described in the table below can be found at *Control* → *Device I/O* → *Digital Outputs* → *Digital Output Settings* in the device settings.

Table. 7.5.2 - 407. Digital output user description.

| Name          | Range  | Default | Description   |
|---------------|--|---------|---|
| OUTx Polarity | <ul style="list-style-type: none"> <li>• NO</li> <li>• NC</li> </ul> | NO      | <p>Digital outputs are configured as “normally open” relays by default. Each output can be changed to “normally closed” using the “OUTx Polarity” parameter. Please note that this change is implemented in software only. If the device is powered off, the outputs will revert to an open state and return to the configured polarity once power is restored.</p> <p>If a truly “normally closed” contact is required, use the changeover relay OUT5 available in the CPU module of the device.</p> |

## Digital output descriptions

Option card outputs can be given a description. The user defined description are displayed in most of the menus:

- logic editor
- matrix
- block settings
- event history
- disturbance recordings
- etc.

The parameters described in the table below can be found at *Control* → *Device I/O* → *Digital Outputs* → *Digital Output Descriptions* in the device settings.

Table. 7.5.2 - 408. Digital output user description.

| Name                           | Range             | Default | Description  |
|--------------------------------|-------------------|---------|--|
| User editable description OUTx | 1...31 characters | OUTx    | Description of the digital output. This description is used in several menu types for easier identification. |



### NOTICE!

After editing user descriptions the event history will start to use the new description only after resetting the HMI. HMI can be reset from *General* → *Device info* → *HMI restart*.

### 7.5.3 High-speed and high-current output module (optional)

Figure. 7.5.3 - 211. High-speed and high-current output module with three add-on high-speed outputs. Can be equipped with standard screw terminals or spring cage terminals for connection.

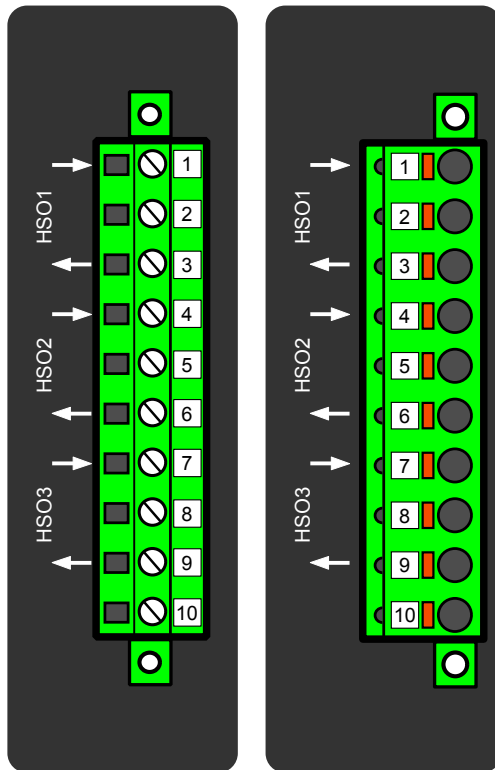

| Connector | Description  |
|-----------|--------------|
| X 1       | HSOx + 1 in  |
| X 2       | N/A          |
| X 3       | HSOx + 1 out |
| X 4       | HSOx + 2 in  |
| X 5       | N/A          |
| X 6       | HSOx + 2 out |
| X 7       | HSOx + 3 in  |
| X 8       | N/A          |
| X 9       | HSOx + 3 out |
| X 10      | N/A          |

The high-speed and high-current module is an add-on module with three (3) hybrid outputs consisting of a semiconductor and a relay connected in parallel. This module can be ordered directly to be installed into the device in the factory, or it can be upgraded in the field after the device's original installation when required. Output control logic is user configurable. All high-speed outputs are controlled in 1 ms program cycles.

For technical details please refer to the chapter titled "[High-speed output module](#)" in the "Technical data" section of this document.

The hardware configuration code of this module is "R". For more information, please refer to the "[Ordering information](#)" chapter of this document.

## HSO Input Settings menu

The parameters described in the table below can be found at *Control* → *Device I/O* → *HSO Inputs* → *HSO Input Settings* in the device settings.

Table. 7.5.3 - 409. HSO input parameters.

| Name                             | Range   | Step    | Default  | Description  |
|----------------------------------|---|---------|----------|--|
| HSO1...9<br>TCS<br>Polarity      | NC (Normally closed)  | -       | NC       | The inputs on high-speed output cards are normally closed contacts, meaning they remain in the closed state under normal conditions and indicate '0' when the circuit is energized.  |
| HSO1...9<br>TCS<br>Drop-off time | 0.000...1800.000 s  | 0.001 s | 0.200 s  | Defines the delay when the status changes from 0 to 1.   |
| HSO1...9<br>TCS AC<br>Mode       | <ul style="list-style-type: none"> <li>Disabled</li> <li>Enabled</li> </ul> | -       | Disabled | Selects whether or not a 30 ms deactivation delay is added to take the alternating current into account. The "DIx Release threshold" parameter is hidden and forced to 10 % of the set "DIx Activation threshold" parameter. |
| HSO1...9<br>TCS<br>Counter       | 0...4294967295  | 1       | 0        | Displays the number of times the input has changed its status from 0 to 1.   |
| HSO1...9<br>TCS<br>Clear counter | <ul style="list-style-type: none"> <li>-</li> <li>Clear</li> </ul>          | -       | -        | Resets the input activation counter value to zero.   |

## HSO Output Settings menu

The parameters described in the table below can be found at *Control* → *Device I/O* → *HSO Outputs* → *HSO Output Settings* in the device settings.

Table. 7.5.3 - 410. HSO output parameters.

| Name                 | Range  | Step | Default | Description   |
|----------------------|--|------|---------|---|
| HSO1...9<br>Polarity | <ul style="list-style-type: none"> <li>NO</li> <li>NC</li> </ul> | -    | NO      | The inputs on high-speed output cards are normally closed contacts, meaning they remain in the closed state under normal conditions and indicate '0' when the circuit is energized. |

## HSO output and input descriptions

Option card outputs and inputs can be given a description. The user defined description are displayed in most of the menus:

- logic editor
- matrix

- block settings
- event history
- disturbance recordings
- etc.

Table. 7.5.3 - 411. HSO input and output user description.

| Name                                   | Range             | Default      | Description   |
|--|-------------------|--------------|---|
| User editable description HSOx         | 1...31 characters | HSOx         | Description of the high-speed output. This description is used in several menu types for easier identification. |
| User editable description HSO1...9 TCS | 1...31 characters | HSO1...9 TCS | Description of the high-speed output. This description is used in several menu types for easier identification. |

**NOTICE!**

After editing user descriptions the event history will start to use the new description only after resetting the HMI. HMI can be reset from *General* → *Device info* → *HMI restart*.

## 7.5.4 Milliampere output module (4x mA out & 1x mA in) (optional)

Figure. 7.5.4 - 212. Milliampere output (mA) I/O module connections. Can be equipped with standard screw terminals or spring cage terminals for connection.

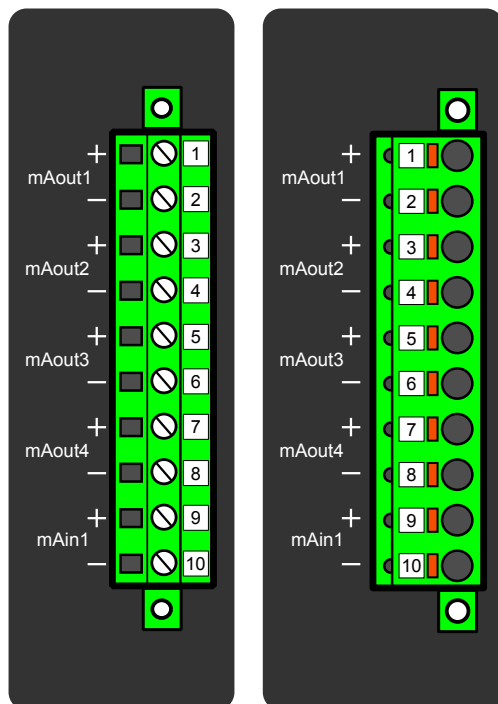

| Connector | Description                      |
|-----------|----------------------------------|
| Pin 1     | mA OUT 1 + connector (0...24 mA) |
| Pin 2     | mA OUT 1 – connector (0...24 mA) |
| Pin 3     | mA OUT 2 + connector (0...24 mA) |

| Connector | Description                      |
|-----------|----------------------------------|
| Pin 4     | mA OUT 2 – connector (0...24 mA) |
| Pin 5     | mA OUT 3 + connector (0...24 mA) |
| Pin 6     | mA OUT 3 – connector (0...24 mA) |
| Pin 7     | mA OUT 4 + connector (0...24 mA) |
| Pin 8     | mA OUT 4 – connector (0...24 mA) |
| Pin 9     | mA IN 1 + connector (0...33 mA)  |
| Pin 10    | mA IN 1 – connector (0...33 mA)  |

The milliampere output (mA) I/O module is an add-on module with four (4) mA outputs and one (1) mA input. Both the outputs and the input are in two galvanically isolated groups, with one pin for the positive (+) connector and one pin for the negative (-) connector.

This module can be ordered directly to be installed into the device in the factory, or it can be upgraded in the field after the device's original installation when required.

The user sets the mA I/O with the mA outputs control function. This can be done at *Control* → *Device I/O* → *mA outputs* in the device configuration settings.

For further information please refer to the chapter titled "[Milliampere output module \(4 x mA out & 1 x mA in\)](#)" in the "Technical data" section of this manual.

The hardware configuration code of this module is "I". For more information, please refer to the "[Ordering information](#)" chapter of this document.

### 7.5.5 Milliampere input module (4x mA in & 1x mA out) (optional)

Figure. 7.5.5 - 213. Milliampere input (mA) I/O module connections. Can be equipped with standard screw terminals or spring cage terminals for connection.

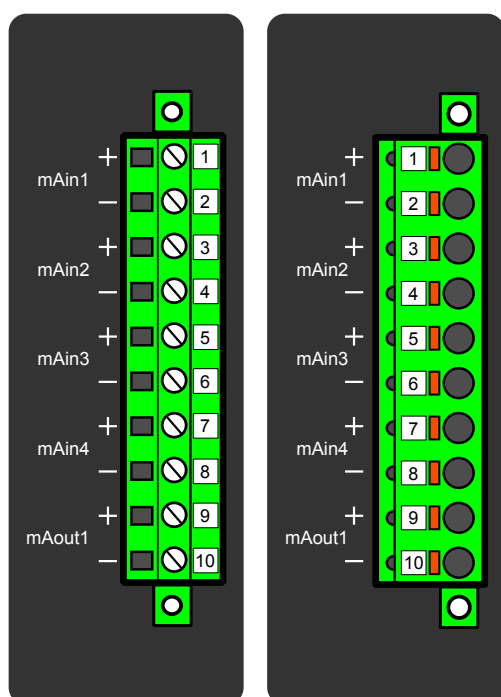

| Connector | Description                      |
|-----------|----------------------------------|
| Pin 1     | mA IN 1 + connector (0...24 mA)  |
| Pin 2     | mA IN 1 – connector (0...24 mA)  |
| Pin 3     | mA IN 2 + connector (0...24 mA)  |
| Pin 4     | mA IN 2 – connector (0...24 mA)  |
| Pin 5     | mA IN 3 + connector (0...24 mA)  |
| Pin 6     | mA IN 3 – connector (0...24 mA)  |
| Pin 7     | mA IN 4 + connector (0...24 mA)  |
| Pin 8     | mA IN 4 – connector (0...24 mA)  |
| Pin 9     | mA OUT 1 + connector (0...33 mA) |
| Pin 10    | mA OUT 1 – connector (0...33 mA) |

The milliampere input (mA) I/O module is an add-on module with four (4) mA inputs and one (1) mA output. Both the inputs and the output are in two galvanically isolated groups, with one pin for the positive (+) connector and one pin for the negative (–) connector.

This module can be ordered directly to be installed into the device in the factory, or it can be upgraded in the field after the device's original installation when required.

The user sets the mA I/O with the mA output control function. This can be done at *Control* → *Device I/O* → *mA outputs* in the device configuration settings.

For further information please refer to the chapter titled "[Milliampere input module \(1x mA out & 4x mA in\)](#)" in the "Technical data" section of this manual.

The hardware configuration code of this module is "T". For more information, please refer to the "[Ordering information](#)" chapter of this document.

## 7.5.6 Point sensor arc protection module (optional)

Figure. 7.5.6 - 214. Arc protection module. Can be equipped with standard screw terminals or spring cage terminals for connection.

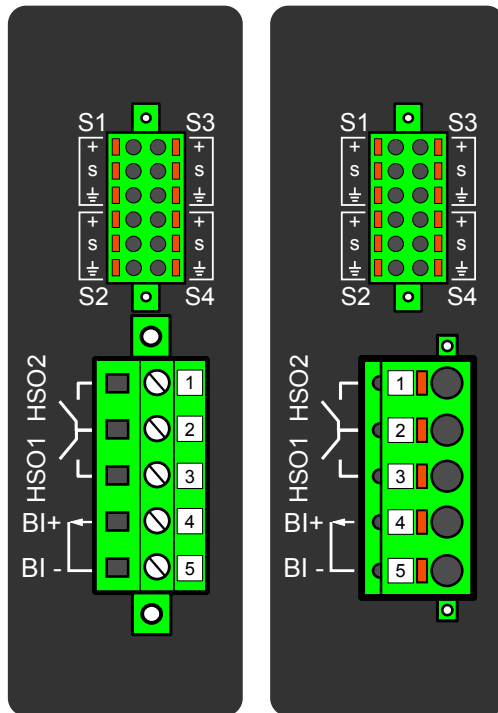

Table. 7.5.6 - 412. Module connections.

| Connector | Description   |
|-----------|---|
| S1        | Light sensor channels 1...4 with positive ("+"), sensor ("S") and earth connectors. |
| S2        |   |
| S3        |   |
| S4        |   |
| X 1       | HSO2 (+, NO)  |
| X 2       | Common battery positive terminal (+) for the HSOs.                                  |
| X 3       | HSO1 (+, NO)  |
| X 4       | Binary input 1 (+ pole)   |
| X 5       | Binary input 1 (- pole)   |

The arc protection module is an add-on module with four (4) light sensor channels, two (2) high-speed semiconductor outputs and one (1) binary input. This module can be ordered directly to be installed into the device in the factory, or it can be upgraded in the field after the device's original installation when required. Each channel can have up to three (3) light sensors serially connected to it.

High-speed outputs can be used as signaling outputs. HSO1 and HSO2 can send overcurrent or light information to external AQ 100 or AQ 250 series devices.

The rated voltage of the binary input is 24 VDC. The pick-up threshold is  $\geq 16$  VDC. The binary input can be used for receiving external light signal or other signals related to arc protection applications. Please note that the binary input's delay is 5...10ms.

**NOTICE!**

BI1, HSO1 and HSO2 are not visible in the *Binary inputs* and *Binary outputs* menus (*Control* → *Device I/O*), they can only be programmed in the arc protection function matrix menu (*Protection* → *Arc protection* → *I/O* → *Direct output control* and *HSO control*).

For further information please refer to the chapter titled "[Point sensor arc protection module](#)" in the "Technical data" section of this manual.

The hardware configuration code of this module is "D". For more information, please refer to the "[Ordering information](#)" chapter of this document.

### 7.5.7 RTD input module (optional)

Figure. 7.5.7 - 215. RTD input module connectors.

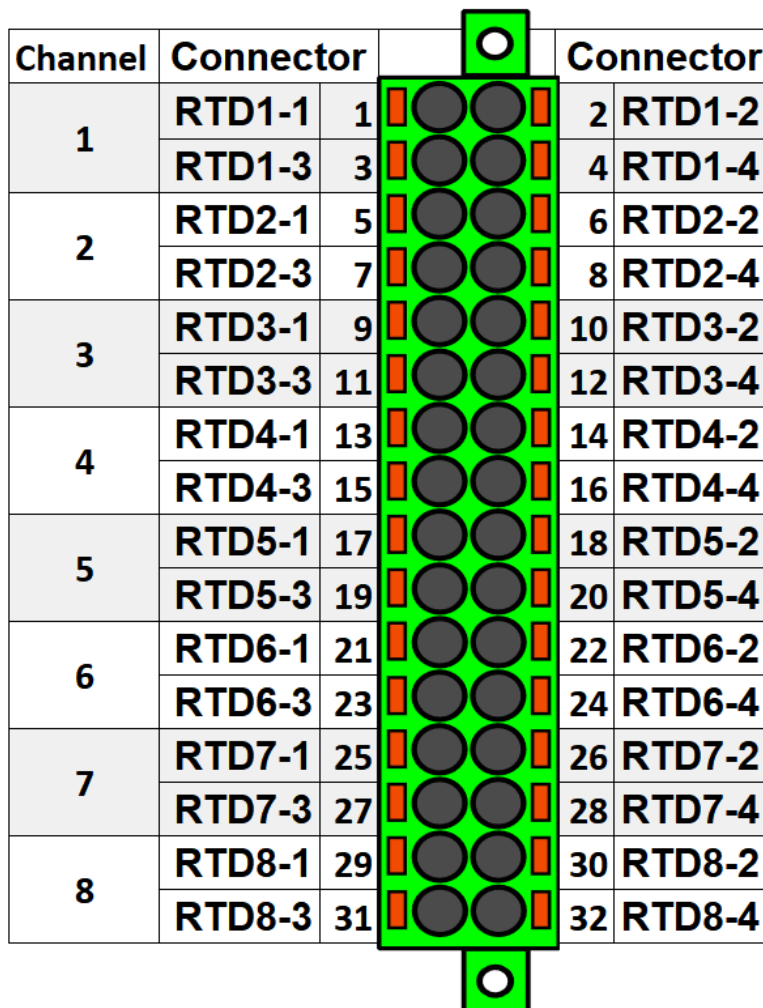

The RTD input module is an add-on module with eight (8) RTD input channels. Each input supports 2-wire, 3-wire and 4-wire RTD sensors. The sensor type can be selected with software for two groups, four channels each. The card supports Pt100 and Pt1000 sensors.

For further information please refer to the chapter titled "[RTD input module](#)" in the "Technical data" section of this manual.

The hardware configuration code of this module is "F". For more information, please refer to the "[Ordering information](#)" chapter of this document.

Figure. 7.5.7 - 216. RTD sensor connection types.

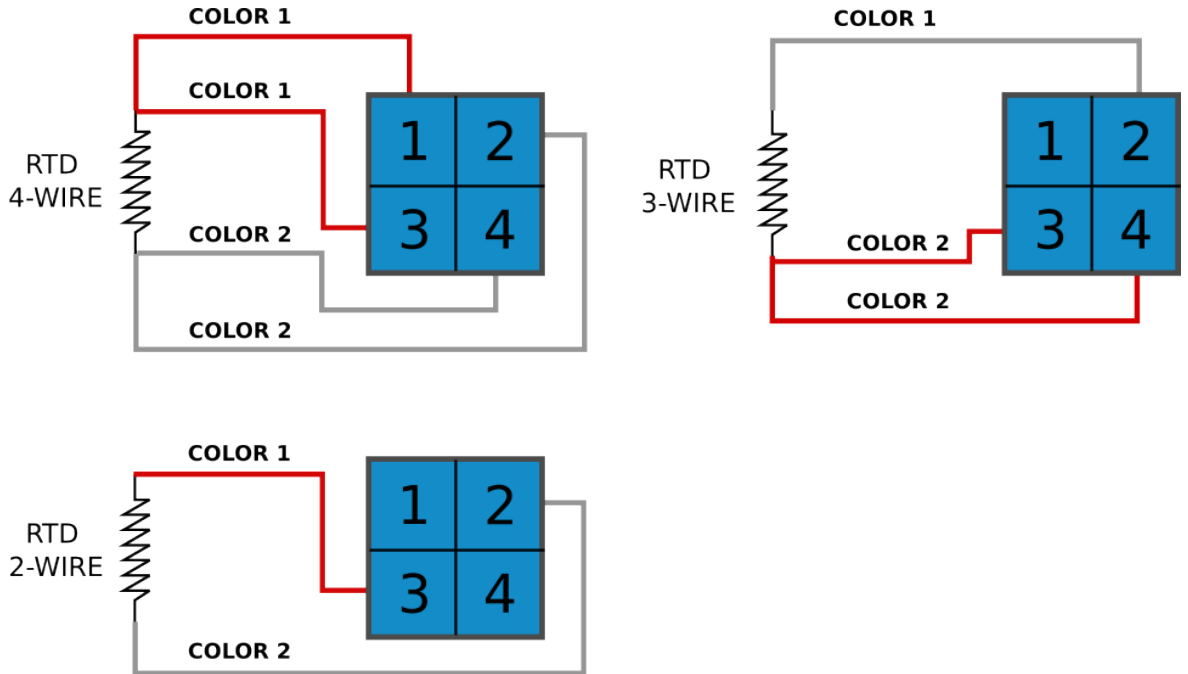

### 7.5.8 Double RJ45 Ethernet & IRIG-B communication module (optional)

Figure. 7.5.8 - 217. Double RJ-45 10/100 Mbps Ethernet communication module.

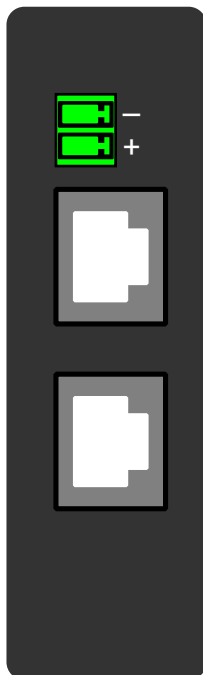

| Connector         | Description   |
|-------------------|---|
| Two-pin connector | <ul style="list-style-type: none"> <li>IRIG-B input</li> </ul>  |
| RJ-45 connectors  | <ul style="list-style-type: none"> <li>Two Ethernet ports</li> <li>RJ-45 connectors</li> <li>10BASE-T and 100BASE-TX</li> </ul> |

This option card supports daisy chain configurations.

For further information please refer to the chapter titled "[Double RJ45 Ethernet & IRIG-B communication module](#)" in the "Technical data" section of this manual.

The hardware configuration code of this module is "G". For more information, please refer to the "[Ordering information](#)" chapter of this document.

### 7.5.9 Double SFP Ethernet & IRIG-B communication module (optional)

Figure. 7.5.9 - 218. Double SFP 100 Mbps Ethernet communication module.

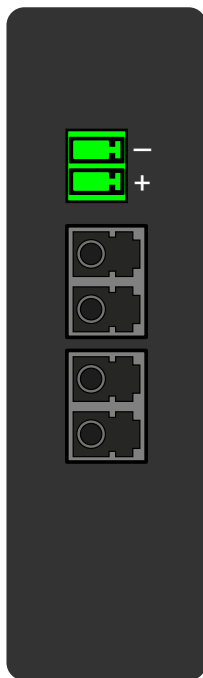

| Connector         | Description  |
|-------------------|--|
| Two-pin connector | <ul style="list-style-type: none"> <li>IRIG-B input</li> </ul>   |
| SFP slots         | <ul style="list-style-type: none"> <li>Two SFP slots</li> <li>Compatible SFP modules available as accessories</li> </ul> |

For further information please refer to the chapter titled "[Double SFP Ethernet & IRIG-B communication module](#)" in the "Technical data" section of this manual.

The hardware configuration code of this module is "Q". For more information, please refer to the "[Ordering information](#)" chapter of this document.

## 7.5.10 Double ST 100 Ethernet & IRIG-B communication module (optional)

Figure. 7.5.10 - 219. Double ST 100 Mbps Ethernet communication module connectors.

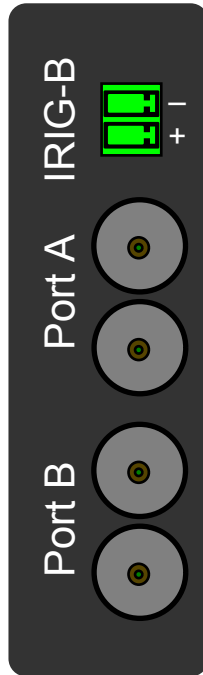

| Connector         | Description  |
|-------------------|--|
| Two-pin connector | <ul style="list-style-type: none"> <li>IRIG-B input</li> </ul>   |
| ST connectors     | <ul style="list-style-type: none"> <li>Duplex ST connectors</li> <li>62.5/125 <math>\mu\text{m}</math> or 50/125 <math>\mu\text{m}</math> multimode fiber</li> <li>Transmitter wavelength: 1260...1360 nm (nominal: 1310 nm)</li> <li>Receiver wavelength: 1100...1600 nm</li> <li>100BASE-FX</li> <li>Up to 2 km</li> </ul> |

This option cards supports redundant ring configuration and multidrop configurations. Please note that each ring can only contain AQ 250 series devices, and any third party devices must be connected to a separate ring.

For further information please refer to the chapter titled "[Double ST Ethernet & IRIG-B communication module](#)" in the "Technical data" section of this manual.

The hardware configuration code of this module is "H". For more information, please refer to the "[Ordering information](#)" chapter of this document.

Figure. 7.5.10 - 220. Example of a multidrop configuration.

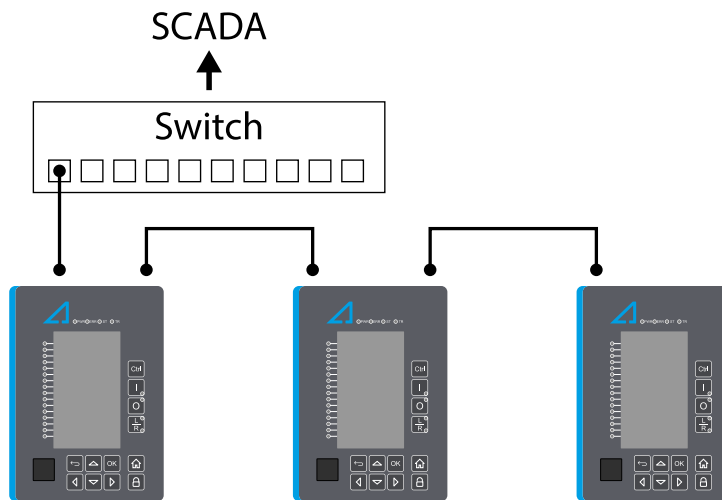

### 7.5.11 Double LC or RJ45 (HSR/PRP) Ethernet communication module (optional)

Figure. 7.5.11 - 221. LC and RJ45 100 Mbps Ethernet module connectors.

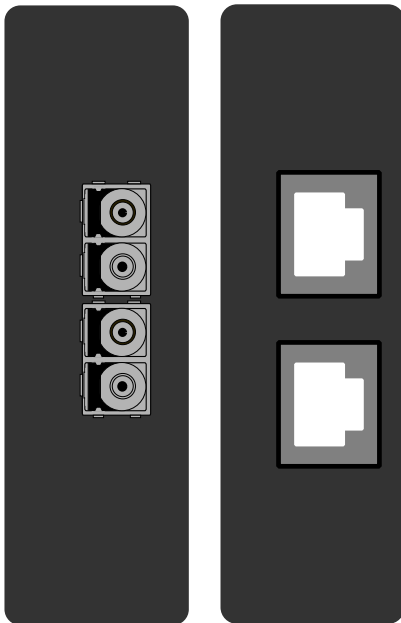

| Card type | Description  |
|-----------|--|
| LC ports  | <ul style="list-style-type: none"> <li>• Communication port D, 100 Mbps LC fiber connector.</li> <li>• 62.5/125 μm or 50/125 μm multimode (glass).</li> <li>• Wavelength 1300 nm.</li> <li>• HSR and PRP protocols supported.</li> </ul> |
| RJ45      | <ul style="list-style-type: none"> <li>• RJ-45 connectors.</li> <li>• 10BASE-T and 100BASE-TX.</li> <li>• HSR and PRP protocols supported.</li> </ul>  |

For further information please refer to the chapters titled "[Double LC \(HSR/PRP\) Ethernet communication module](#)" and "[Double RJ45 \(HSR/PRP\) Ethernet communication module](#)" in the "Technical data" section of this manual.

The hardware configuration codes of these modules are "J" (Double LC 100Mb Ethernet) and "K" (Double RJ45 100Mb Ethernet). For more information, please refer to the "[Ordering information](#)" chapter of this document.

### 7.5.12 Serial RS-232 communication module (optional)

Figure. 7.5.12 - 222. Serial RS-232 module connectors.

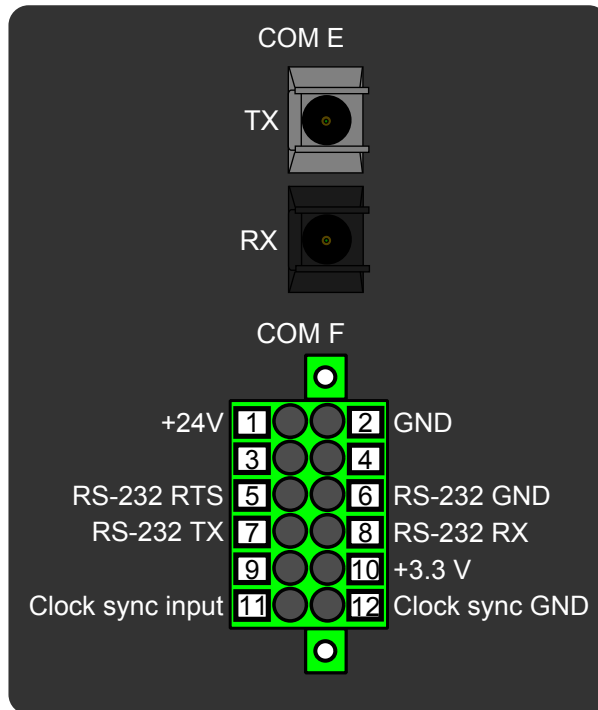

Table. 7.5.12 - 413. Module connections.

| Connector | Pin | Name         | Description  |
|-----------|-----|--------------|--|
| COM E     | -   | Serial fiber | <ul style="list-style-type: none"> <li>Serial-based communications</li> <li>Port options:                             <ul style="list-style-type: none"> <li>Glass/glass</li> <li>Plastic/plastic</li> <li>Glass/plastic</li> <li>Plastic/glass</li> </ul> </li> <li>Wavelength 660 nm</li> <li>Compatible with 50/125 <math>\mu\text{m}</math>, 62.5/125 <math>\mu\text{m}</math>, 100/140 <math>\mu\text{m}</math>, and 200 <math>\mu\text{m}</math> Plastic-Clad Silica (PCS) fiber</li> <li>Compatible with ST connectors</li> </ul> |
| COM F     | 1   | +24 V input  | Optional external auxiliary voltage for serial fiber.  |
|           | 2   | GND          |  |
|           | 3   | -            | Not in use.  |
|           | 4   | -            |  |

| Connector | Pin | Name                  | Description  |
|-----------|-----|-----------------------|--|
|           | 5   | RS-232 RTS            | Serial based communications.                       |
|           | 6   | RS-232 GND            |  |
|           | 7   | RS-232 TX             |  |
|           | 8   | RS-232 RX             |  |
|           | 9   | -                     | Not in use.  |
|           | 10  | +3.3 V output (spare) | Spare power source for external equipment (45 mA). |
|           | 11  | Clock sync input      | Clock synchronization input (supports IRIG-B).     |
|           | 12  | Clock sync GND        |  |

The option card includes two serial communication interfaces: COM E is a serial fiber interface with glass/glass, plastic/plastic, glass/plastic and plastic/glass options, COM F is an RS-232 interface.

For further information please refer to the chapter titled "[RS-232 & serial fiber communication module](#)" in the "Technical data" section of this manual.

The hardware configuration codes of these modules are "L", "M", "N" and "O". For more information, please refer to the "[Ordering information](#)" chapter of this document.

## 7.6 Dimensions and installation

The device can be installed either to a standard 19" rack or to a switchgear panel with cutouts. The desired installation type is defined in the order code.

The figures below describe the device dimensions (first figure), the device installation (second), and the panel cutout dimensions and device spacing (third).

Figure. 7.6 - 223. Device dimensions.

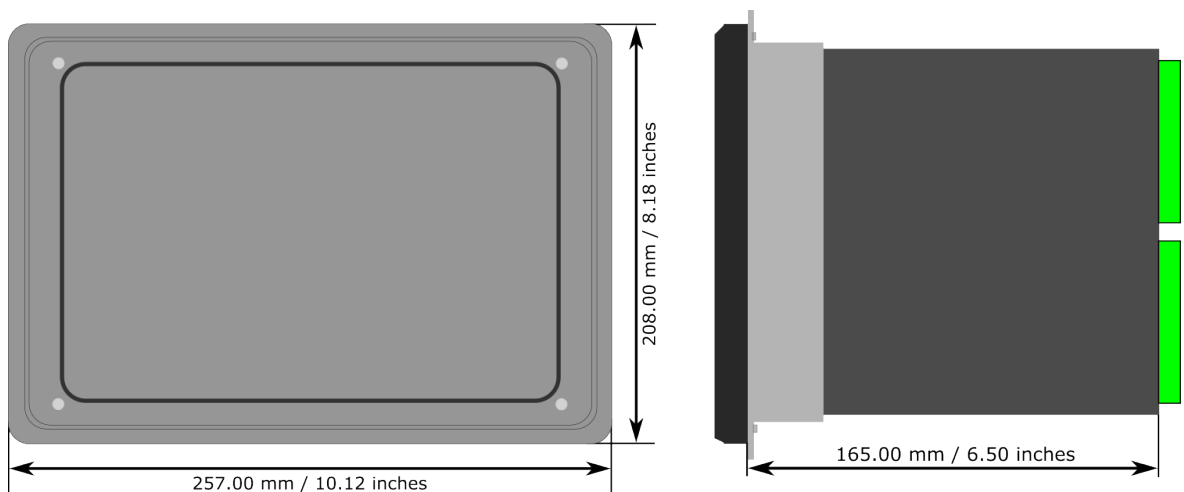

Figure. 7.6 - 224. Device installation.

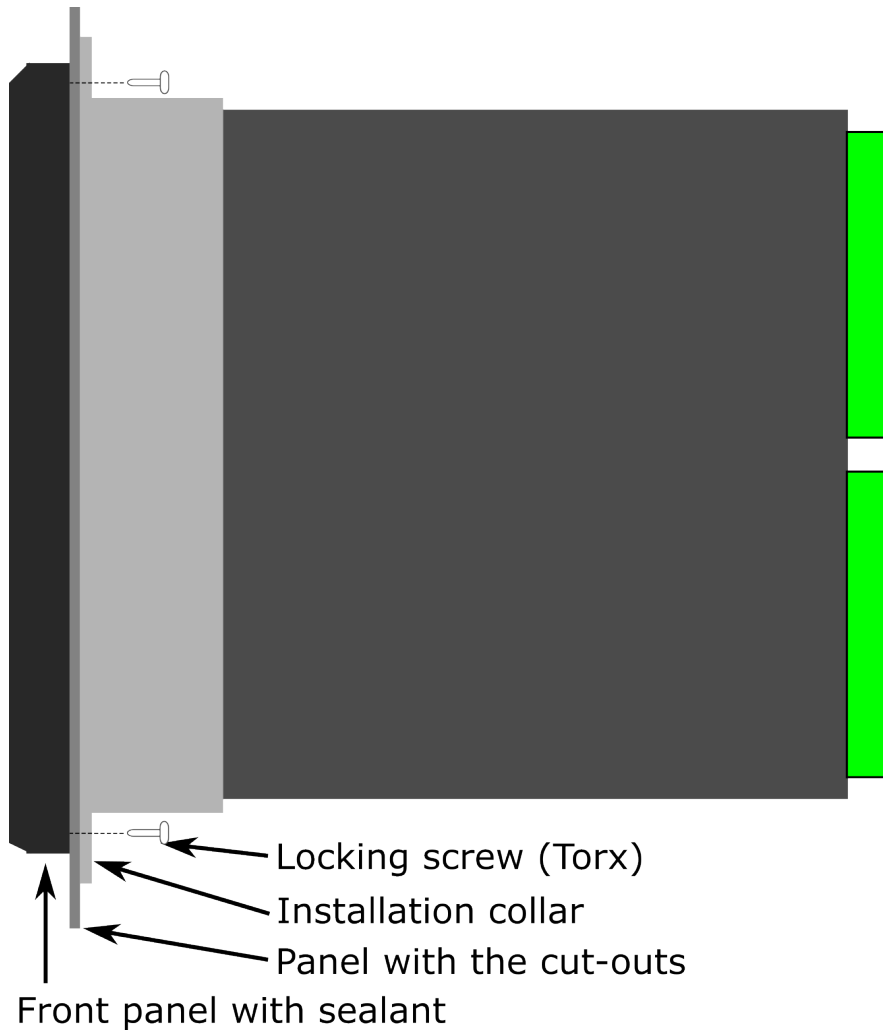
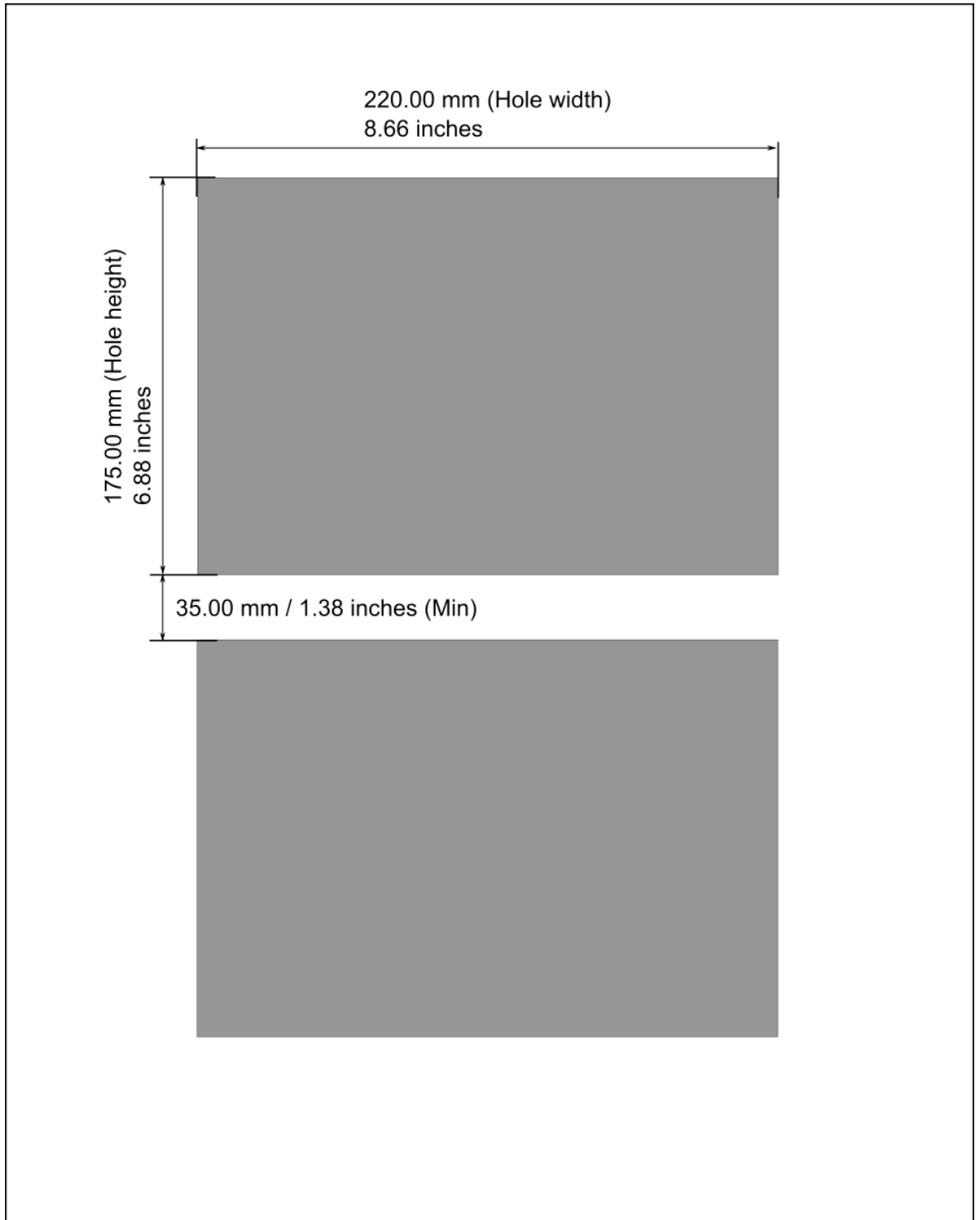

Figure. 7.6 - 225. Panel cut-out and spacing of the devices.



## 8 Technical data

### 8.1 Hardware

#### 8.1.1 Measurements

##### 8.1.1.1 Current measurement

Table. 8.1.1.1 - 414. Technical data for the current measurement module.

| General information                 |  |
|-------------------------------------|--|
| Spare part code                     | #SP-2XX-CM   |
| Compatibility                       | AQ 210 series<br>AQ 250 series<br>AQ-ONE   |
| Connections                         |  |
| Measurement channels/CT inputs      | Three phase current inputs: IL1 (A), IL2 (B), IL3 (C)<br>Two residual current inputs: Coarse residual current input I01, Fine residual current input I02 |
| Phase current inputs (A, B, C)      |  |
| Sample rate                         | 64 samples per cycle in frequency range 6...75Hz   |
| Rated current $I_N$                 | 5 A (configurable 0.2...10 A)  |
| Thermal withstand                   | 20 A (continuous)<br>100 A (for 10 s)<br>500 A (for 1 s)<br>1250 A (for 0.01 s)  |
| Frequency measurement range         | From 6...75Hz fundamental, up to the 31 <sup>st</sup> harmonic current   |
| Current measurement range           | 5 mA...250 A (RMS)   |
| Current measurement inaccuracy      | $0.005...4.000 \times I_N < \pm 0.5 \%$ or $< \pm 15 \text{ mA}$<br>$4...20 \times I_N < \pm 0.5 \%$<br>$20...50 \times I_N < \pm 1.0 \%$                |
| Angle measurement inaccuracy        | $< \pm 0.2^\circ$ ( $I > 0.1 \text{ A}$ )<br>$< \pm 1.0^\circ$ ( $I \leq 0.1 \text{ A}$ )  |
| Burden (50/60 Hz)                   | $< 0.1 \text{ VA}$   |
| Transient overreach                 | $< 8 \%$   |
| Coarse residual current input (I01) |  |
| Rated current $I_N$                 | 1 A (configurable 0.1...10 A)  |

|  |   |
|--|---|
| Thermal withstand                                  | 25 A (continuous)<br>100 A (for 10 s)<br>500 A (for 1 s)<br>1250 A (for 0.01 s)             |
| Frequency measurement range                        | From 6...75 Hz fundamental, up to the 31 <sup>st</sup> harmonic current                     |
| Current measurement range                          | 5 mA...150 A (RMS)  |
| Current measurement inaccuracy                     | 0.002...10.000 × I <sub>N</sub> < ±0.5 % or < ±3 mA<br>10...150 × I <sub>N</sub> < ±0.5 %   |
| Angle measurement inaccuracy                       | < ±0.2° (I > 0.05 A)<br>< ±1.0° (I ≤ 0.05 A)  |
| Burden (50/60Hz)                                   | <0.1 VA   |
| Transient overreach                                | <5 %  |
| <b>Fine residual current input (I02)</b>           |   |
| Rated current I <sub>N</sub>                       | 0.2 A (configurable 0.001...10 A)   |
| Thermal withstand                                  | 25 A (continuous)<br>100 A (for 10 s)<br>500 A (for 1 s)<br>1250 A (for 0.01 s)             |
| Frequency measurement range                        | From 6...75 Hz fundamental, up to the 31 <sup>st</sup> harmonic current                     |
| Current measurement range                          | 1 mA...75 A (RMS)   |
| Current measurement inaccuracy                     | 0.002...25.000 × I <sub>N</sub> < ±0.5 % or < ±0.6 mA<br>25...375 × I <sub>N</sub> < ±1.0 % |
| Angle measurement inaccuracy                       | < ±0.2° (I > 0.01 A)<br>< ±1.0° (I ≤ 0.01 A)  |
| Burden (50/60Hz)                                   | <0.1 VA   |
| Transient overreach                                | <5 %  |
| <b>Screw connection terminal block (standard)</b>  |   |
| Nominal cross section (solid or stranded wire)     | 4 mm <sup>2</sup>   |
| <b>Ring lug terminal block connection (option)</b> |   |
| Ring terminal dimensions                           | Max 8mm diameter, with minimum 3,5mm screw hole   |

**NOTICE!**

Current measurement accuracy has been verified with 50/60 Hz.

The amplitude difference is 0.2 % and the angle difference is 0.5 degrees higher at 16.67 Hz and other frequencies.

## 8.1.1.2 Voltage measurement

Table. 8.1.1.2 - 415. Technical data for the voltage measurement module.

| General information                            |  |
|--|--|
| Spare part code                                | #SP-2XX-VT   |
| Compatibility                                  | AQ 210 series<br>AQ 250 series<br>AQ-ONE                               |
| Connection                                     |  |
| Measurement channels/VT inputs                 | 4 independent VT inputs (U1, U2, U3 and U4)                            |
| Measurement                                    |  |
| Sample rate                                    | 64 samples per cycle in frequency range 6...75Hz                       |
| Voltage measuring range                        | 0.50...480.00 V (RMS)  |
| Rated voltage $U_N$                            | 100 V / 110 V / 115 V / 120 V (RMS)                                    |
| Voltage measurement inaccuracy                 | 1...2 V $\pm 1.5\%$<br>2...10 V $\pm 0.5\%$<br>10...480 V $\pm 0.35\%$ |
| Angle measurement inaccuracy                   | $\pm 0.2$ degrees (15...300 V)<br>$\pm 1.5$ degrees (1...15 V)         |
| Voltage measurement bandwidth (freq.)          | 7...75 Hz fundamental, up to the 31 <sup>st</sup> harmonic voltage     |
| Terminal block connection                      |  |
| Nominal cross section (solid or stranded wire) | 6 mm <sup>2</sup>  |
| Input impedance                                | $\sim 24.5\text{ M}\Omega$   |
| Burden (50/60 Hz)                              | <0.02 VA   |
| Thermal withstand                              | 630 V <sub>RMS</sub> (continuous)                                      |



**NOTICE!**

Voltage measurement accuracy has been verified with 50/60 Hz.

The amplitude difference is 0.2 % and the angle difference is 0.5 degrees higher at 16.67 Hz and other frequencies.

## 8.1.1.3 Voltage memory

Table. 8.1.1.3 - 416. Technical data for the voltage memory function.

| Measurement inputs |
|--------------------|
|--------------------|

|  |   |
|--|---|
| Voltage inputs   | $U_{L1}, U_{L2}, U_{L3}$<br>$U_{L12}, U_{L23}, U_{L31} + U_0$   |
| Current inputs (back-up frequency)                                       | Phase current inputs: $I_{L1}$ (A), $I_{L2}$ (B), $I_{L3}$ (C)  |
| <b>Pick-up</b>   |   |
| Pick-up voltage setting<br>Pick-up current setting (optional)            | 2.00...50.00 % $U_N$ , setting step $0.01 \times \%U_N$<br>$0.01...50.00 \times I_N$ , setting step $0.01 \times I_N$ |
| Inaccuracy:<br>- Voltage<br>- Current                                    | $\pm 1.5 \%U_{SET}$ or $\pm 30$ mV<br>$\pm 0.5 \%I_{SET}$ or $\pm 15$ mA ( $0.10...4.0 \times I_{SET}$ )              |
| <b>Operation time</b>  |   |
| Angle memory activation delay  | <20 ms (typically 5 ms)   |
| Maximum active time  | 0.020...50.000 s, setting step 0.005 s  |
| Inaccuracy:<br>- Definite time ( $U_M/U_{SET}$ ratio >1.05)              | $\pm 1.0 \%$ or $\pm 35$ ms   |
| <b>Angle memory</b>  |   |
| Angle drift while voltage is absent                                      | $\pm 1.0^\circ$ per 1 second  |
| <b>Reset</b>   |   |
| Reset ratio:<br>- Voltage memory (voltage)<br>- Voltage memory (current) | 103 % of the pick-up voltage setting<br>97 % of the pick-up current setting   |
| Reset time   | <50 ms  |

**NOTICE!**

Voltage memory is activated only when all line voltages fall below set pick-up value.

**NOTICE!**

Voltage memory activation captures healthy situation voltage angles, one cycle before actual activation (50Hz/20ms before "bolted" fault)

### 8.1.1.4 Power and energy measurement

Table. 8.1.1.4 - 417. Power and energy measurement accuracy

|                                      |  |
|--------------------------------------|--|
| <b>Power measurement P, Q, S</b>     | <b>Frequency range 6...75 Hz</b>   |
| Inaccuracy                           | 0.3 % $< 1.2 \times I_N$ or 3 VA secondary<br>1.0 % $> 1.2 \times I_N$ or 3 VA secondary                                     |
| <b>Energy measurement</b>            | <b>Frequency range 6...75 Hz</b>   |
| Energy and power metering inaccuracy | 0.5% down to 1A RMS (50/60Hz) as standard<br>0.2% down to 1A RMS (50/60Hz) option available (see the order code for details) |

### 8.1.1.5 Frequency measurement

Table. 8.1.1.5 - 418. Frequency measurement accuracy.

| Frequency measurement performance |   |
|-----------------------------------|---|
| Frequency measuring range         | 6...75 Hz fundamental, up to the 31 <sup>st</sup> harmonic current or voltage |
| Inaccuracy                        | 10 mHz  |

### 8.1.2 CPU & Power supply

Table. 8.1.2 - 419. General information for the CPU module.

| General information                             |  |
|---|--|
| Spare part code                                 | #SP-250-CPU                              |
| Compatibility                                   | AQ 210 series<br>AQ 250 series<br>AQ-ONE |
| Terminal block connection                       |  |
| Solid or stranded wire<br>Nominal cross section | 2.5 mm <sup>2</sup>                      |
| RS-485 serial terminal block connection         |  |
| Maximum cross section (solid or stranded wire)  | 1.5 mm <sup>2</sup>                      |

#### 8.1.2.1 Auxiliary voltage

Table. 8.1.2.1 - 420. Power supply model A

| Rated values                     |   |
|----------------------------------|---|
| Rated auxiliary voltage          | 80...265 V (AC/DC)  |
| Power consumption                | < 20 W (no option cards)<br>< 40 W (maximum number of option cards) |
| Maximum permitted interrupt time | < 40 ms with 110 VDC  |
| DC ripple                        | < 15 %  |
| Other                            |   |
| Minimum recommended fuse rating  | MCB C2  |

Table. 8.1.2.1 - 421. Power supply model B

| Rated values |  |
|--------------|--|
|--------------|--|

|                                  |   |
|----------------------------------|---|
| Rated auxiliary voltage          | 18...72 VDC   |
| Power consumption                | < 20 W (no option cards)<br>< 40 W (maximum number of option cards) |
| Maximum permitted interrupt time | < 40 ms with 24 VDC   |
| DC ripple                        | < 15 %  |
| <b>Other</b>                     |   |
| Minimum recommended fuse rating  | MCB C2  |

### 8.1.2.2 CPU communication ports

Table. 8.1.2.2 - 422. Front panel local communication port.

|                    |  |
|--------------------|--|
| <b>Port</b>        |  |
| Port media         | Copper Ethernet RJ-45  |
| Number of ports    | 1  |
| Port protocols     | PC-protocols<br>FTP  |
| <b>Features</b>    |  |
| Data transfer rate | 100 MB/s   |
| System integration | Can't be used for system protocols, only for local programming |

Table. 8.1.2.2 - 423. Rear panel system communication port A.

|                    |   |
|--------------------|---|
| <b>Port</b>        |   |
| Port media         | Copper Ethernet RJ-45   |
| Number of ports    | 1   |
| <b>Features</b>    |   |
| Port protocols     | IEC 61850 (1st edition)<br>IEC61850 (2nd edition)<br>IEC 104<br>Modbus/TCP<br>DNP3<br>FTP |
| Data transfer rate | 100 MB/s  |
| System integration | Can be used for system protocols and for local programming                                |

Table. 8.1.2.2 - 424. Rear panel system communication port B.

|             |
|-------------|
| <b>Port</b> |
|-------------|

|                    |   |
|--------------------|---|
| Port media         | Copper RS-485                                   |
| Number of ports    | 1   |
| <b>Features</b>    |   |
| Port protocols     | Modbus/RTU<br>IEC 103<br>IEC 101<br>DNP3<br>SPA |
| Data transfer rate | 65 580 kB/s                                     |
| System integration | Can be used for system protocols                |

### 8.1.2.3 CPU digital inputs

Table. 8.1.2.3 - 425. CPU model-isolated digital inputs, with thresholds defined by order code.

|  |  |
|--|--|
| <b>Rated values</b>                    |  |
| Rated auxiliary voltage                | 265 V (AC/DC)  |
| Nominal voltage                        | Order code defined: 24, 110, 220 V (AC/DC)                             |
| Pick-up threshold<br>Release threshold | Order code defined: 19, 90, 170 V<br>Order code defined: 14, 65, 132 V |
| Scanning rate                          | 5 ms   |
| <b>Settings</b>                        |  |
| Pick-up delay                          | Software settable: 0...1800 s  |
| Polarity                               | Software settable: Normally On/Normally Off                            |
| Current drain                          | 2 mA   |

### 8.1.2.4 CPU digital outputs

Table. 8.1.2.4 - 426. Digital outputs (Normally Open)

|  |                       |
|--|-----------------------|
| <b>Rated values</b>  |                       |
| Rated auxiliary voltage  | 265 V (AC/DC)         |
| Continuous carry   | 5 A                   |
| Make and carry 0.5 s<br>Make and carry 3 s                                   | 30 A<br>15 A          |
| Breaking capacity, DC (L/R = 40 ms)<br>at 48 VDC<br>at 110 VDC<br>at 220 VDC | 1 A<br>0.4 A<br>0.2 A |

|                 |  |
|-----------------|--|
| Control rate    | 5 ms   |
| <b>Settings</b> |  |
| Polarity        | Software settable: Normally Open / Normally Closed |

Table. 8.1.2.4 - 427. Digital outputs (Change-Over)

|  |  |
|--|--|
| <b>Rated values</b>  |  |
| Rated auxiliary voltage  | 265 V (AC/DC)                                      |
| Continuous carry   | 2.5 A  |
| Make and carry 0.5 s<br>Make and carry 3 s                                   | 30 A<br>15 A                                       |
| Breaking capacity, DC (L/R = 40 ms)<br>at 48 VDC<br>at 110 VDC<br>at 220 VDC | 1 A<br>0.3 A<br>0.15 A                             |
| Control rate   | 5 ms   |
| <b>Settings</b>  |  |
| Polarity   | Software settable: Normally Open / Normally Closed |

**CAUTION!**

Please note, that signaling relay 5 and system fault's signaling relay are designed only for signaling purposes, and are not to be used in trip coil control.

## 8.1.3 Option cards

### 8.1.3.1 Digital input module

Table. 8.1.3.1 - 428. Technical data for the digital input module.

|   |  |
|---|--|
| Spare part code                           | #SP-250-DI8  |
| Compatibility                             | AQ 210 series models<br>AQ 250 series models<br>AQ-ONE |
| <b>Rated values</b>                       |  |
| Rated auxiliary voltage                   | 5...265 V (AC/DC)                                      |
| Current drain                             | 2 mA   |
| Scanning rate<br>Activation/release delay | 5 ms<br>5...11 ms                                      |
| <b>Settings</b>                           |  |

|   |  |
|---|--|
| Pick-up threshold<br>Release threshold          | Software settable: 16...200 V, setting step 1 V<br>Software settable: 10...200 V, setting step 1 V |
| Pick-up delay                                   | Software settable: 0... 1800 s   |
| Drop-off delay                                  | Software settable: 0... 1800 s   |
| Polarity  | Software settable: Normally On/Normally Off  |
| <b>Terminal block connection</b>                |  |
| Solid or stranded wire<br>Nominal cross section | 2.5 mm <sup>2</sup>  |

### 8.1.3.2 Digital output module

Table. 8.1.3.2 - 429. Technical data for the digital output module.

|  |  |
|--|--|
| Spare part code  | #SP-250-DO5  |
| Compatibility  | AQ 210 series models<br>AQ 250 series models<br>AQ-ONE |
| <b>Rated values</b>  |  |
| Rated auxiliary voltage  | 265 V (AC/DC)  |
| Continuous carry   | 5 A  |
| Make and carry 0.5 s<br>Make and carry 3 s                                   | 30 A<br>15 A   |
| Breaking capacity, DC (L/R = 40 ms)<br>at 48 VDC<br>at 110 VDC<br>at 220 VDC | 1 A<br>0.4 A<br>0.2 A                                  |
| Control rate   | 5 ms   |
| <b>Settings</b>  |  |
| Polarity   | Software settable: Normally On/Normally Off            |
| <b>Terminal block connection</b>   |  |
| Maximum cross section (solid or stranded wire)                               | 2.5 mm <sup>2</sup>                                    |

### 8.1.3.3 High-speed and high-current output module

Table. 8.1.3.3 - 430. Technical data for the high-speed and high-current output module.

|                 |                                |
|-----------------|--------------------------------|
| Spare part code | #SP-250-HSO                    |
| Compatibility   | AQ 250 series models<br>AQ-ONE |

| High-speed output rated values   |   |
|--|---|
| Rated auxiliary voltage  | 265 V (AC/DC)                               |
| Continuous carry   | 10 A  |
| Make and carry 0.5 s<br>Make and carry 3 s                                   | 30 A<br>15 A                                |
| Breaking capacity, DC (L/R = 40 ms)<br>at 48 VDC<br>at 110 VDC<br>at 220 VDC | 10 A  |
| Control rate   | 1 ms  |
| Operating time   | Typically under 4 ms                        |
| Trip Circuit Supervision input rated values                                  |   |
| Rated auxiliary voltage  | 265 V (AC/DC)                               |
| Nominal voltage  | Order code defined: 24, 110, 220 V (AC/DC)  |
| Pick-up threshold  | Order code defined: 19, 90, 170 V           |
| Release threshold  | Order code defined: 14, 65, 132 V           |
| Scanning rate  | 5 ms  |
| High-speed output settings   |   |
| Polarity   | Software settable: Normally On/Normally Off |
| Trip Circuit Supervision input settings                                      |   |
| Release delay  | Software settable: 0.000...1800.000 s       |
| Polarity   | Normally Closed                             |
| Current drain  | 2 mA  |
| Terminal block connection  |   |
| Maximum cross section (solid or stranded wire)                               | 2.5 mm <sup>2</sup>                         |

### 8.1.3.4 Milliampere output module (4 x mA out & 1 x mA in)

Table. 8.1.3.4 - 431. Technical data for the milliampere output module.

| Spare part code                       | #SP-2XX-MA   |
|---------------------------------------|--|
| Compatibility                         | AQ 210 series models<br>AQ 250 series models<br>AQ-ONE |
| Signals                               |  |
| Output magnitudes<br>Input magnitudes | 4 x mA output signal (DC)<br>1 x mA input signal (DC)  |

| mA input                                       |   |
|--|---|
| Range (hardware)                               | 0...33 mA   |
| Range (measurement)                            | 0...24 mA   |
| Inaccuracy                                     | ±0.1 mA   |
| Update cycle                                   | 5...10 000 ms, setting step 5 ms                      |
| Response time at 5 ms cycle                    | ~ 15 ms (13...18 ms)                                  |
| Update cycle time inaccuracy                   | Max. +20 ms above the set cycle                       |
| mA input scaling range                         | 0...4000 mA   |
| Output scaling range                           | -1 000 000.0000...1 000 000.0000, setting step 0.0001 |
| mA output                                      |   |
| Inaccuracy at 0...24 mA                        | ±0.01 mA  |
| Response time at 5 ms cycle [fixed]            | < 5 ms  |
| mA output scaling range                        | 0...24 mA, setting step 0.001 mA                      |
| Source signal scaling range                    | -1 000 000.000...1 000 000.0000, setting step 0.0001  |
| Terminal block connection                      |   |
| Maximum cross section (solid or stranded wire) | 2.5 mm <sup>2</sup>                                   |

### 8.1.3.5 Milliampere input module (1x mA out & 4x mA in)

Table. 8.1.3.5 - 432. Technical data for the milliampere input module.

| Spare part code                     | #SP-250-MAIN  |
|-------------------------------------|---|
| Compatibility                       | AQ 250 series models<br>AQ-ONE                        |
| Signals                             |   |
| Input magnitudes                    | 4 × mA input signal (DC)                              |
| Output magnitudes                   | 1 × mA output signal (DC)                             |
| mA input                            |   |
| Range (hardware)                    | 0...33 mA   |
| Range (measurement)                 | 0...24 mA   |
| Inaccuracy                          | ±0.1 mA   |
| Update cycle                        | 5...10 000 ms, setting step 5 ms                      |
| Response time at 5 ms cycle         | ~ 15 ms (13...18 ms)                                  |
| Update cycle time inaccuracy        | Max. +20 ms above the set cycle                       |
| mA input scaling range              | 0...4000 mA   |
| Output scaling range                | -1 000 000.0000...1 000 000.0000, setting step 0.0001 |
| mA output                           |   |
| Inaccuracy at 0...24 mA             | ±0.01 mA  |
| Response time at 5 ms cycle [fixed] | < 5 ms  |

|  |  |
|--|--|
| mA output scaling range                        | 0...24 mA, setting step 0.001 mA                     |
| Source signal scaling range                    | -1 000 000.000...1 000 000.0000, setting step 0.0001 |
| <b>Terminal block connection</b>               |  |
| Maximum cross section (solid or stranded wire) | 2.5 mm <sup>2</sup>                                  |

### 8.1.3.6 Point sensor arc protection module

Table. 8.1.3.6 - 433. Technical data for the point sensor arc protection module.

|   |  |
|---|--|
| Spare part code                               | #SP-2XX-ARC  |
| Compatibility                                 | AQ 210 series models<br>AQ 250 series models<br>AQ-ONE   |
| <b>Connections</b>                            |  |
| Input arc point sensor channels               | S1, S2, S3, S4 (pressure and light, or light only)   |
| Sensors per channel                           | 3  |
| Maximum cable length                          | 200 m  |
| <b>Performance</b>                            |  |
| Pick-up light intensity                       | 8, 25 or 50 kLx (the sensor is selectable in the order code)   |
| Point sensor detection radius                 | 180 degrees  |
| Start and instant operating time (light only) | Typically <5 ms with dedicated semiconductor outputs (HSO)<br>Typically <10 ms regular output relays |

Table. 8.1.3.6 - 434. High-Speed Outputs (HSO1...2)

|  |               |
|--|---------------|
| <b>Rated values</b>                        |               |
| Rated auxiliary voltage                    | 250 VDC       |
| Continuous carry                           | 2 A           |
| Make and carry 0.5 s<br>Make and carry 3 s | 10 A<br>6 A   |
| Breaking capacity, DC (L/R = 40 ms)        | 1 A/110 W     |
| Control rate                               | 5 ms          |
| Operation delay                            | <1 ms         |
| Polarity                                   | Normally Off  |
| Contact material                           | Semiconductor |



**CAUTION!**

Please note that signaling relay 5 and system fault's signaling relay are designed only for signaling purposes! They are not to be used in trip coil control.

Table. 8.1.3.6 - 435. Binary input channel

| Rated values  |                              |
|---|------------------------------|
| Voltage withstand   | 265 VDC                      |
| Nominal voltage<br>Pick-up threshold<br>Release threshold | 24 VDC<br>≥16 VDC<br>≤15 VDC |
| Scanning rate   | 5 ms                         |
| Polarity  | Normally Off                 |
| Current drain   | 3 mA                         |

Table. 8.1.3.6 - 436. Terminal block connections

| Arc point sensor terminal block connections     |                     |
|---|---------------------|
| Maximum cross section (Solid or stranded wire)  | 1.5 mm <sup>2</sup> |
| Binary input and HSO terminal block connections |                     |
| Maximum cross section (solid or stranded wire)  | 2.5 mm <sup>2</sup> |



**NOTICE!**

The polarity must be correct!

### 8.1.3.7 RTD input module

Table. 8.1.3.7 - 437. Technical data for the RTD input module.

| Spare part code                                | #SP-2xx-RTD  |
|--|--|
| Compatibility                                  | AQ 210 series models<br>AQ 250 series models<br>AQ-ONE |
| Channels 1-8                                   |  |
| 2/3/4-wire RTD                                 |  |
| Pt100 or Pt1000                                |  |
| Terminal block connection                      |  |
| Maximum cross section (solid or stranded wire) | 1.5 mm <sup>2</sup>                                    |

### 8.1.3.8 Double RJ-45 Ethernet & IRIG-B communication module

Table. 8.1.3.8 - 438. Technical data for the double RJ-45 Ethernet communication module.

|  |  |
|--|--|
| Spare part code                                | #SP-2XX-ETH-RJ45   |
| Compatibility                                  | AQ 210 series models<br>AQ 250 series models<br>AQ-ONE     |
| <b>Ethernet connector features</b>             |  |
| Protocols                                      | IEC 61850<br>IEC 104<br>Modbus/TCP<br>DNP3<br>FTP          |
| Data transfer rate                             | 100 MB/s   |
| System integration                             | Can be used for system protocols and for local programming |
| Number of ports                                | 2  |
| Communication ports                            | Copper Ethernet RJ-45                                      |
| <b>IRIG-B Connector</b>                        |  |
| Maximum cross section (solid or stranded wire) | 1.5 mm <sup>2</sup>  |

### 8.1.3.9 Double SFP Ethernet & IRIG-B communication module

Table. 8.1.3.9 - 439. Technical data for the double SFP Ethernet communication module.

|                                    |  |
|------------------------------------|--|
| Spare part code                    | #SP-250-ETH-SFP  |
| Compatibility                      | AQ 250 series models<br>AQ-ONE                             |
| <b>Ethernet connector features</b> |  |
| Protocols                          | IEC 61850<br>IEC 104<br>Modbus/TCP<br>DNP3<br>FTP          |
| Data transfer rate                 | 100 MB/s   |
| System integration                 | Can be used for system protocols and for local programming |
| Number of ports                    | 2  |
| Communication ports                | SFP  |
| <b>IRIG-B Connector</b>            |  |

|  |                     |
|--|---------------------|
| Maximum cross section (solid or stranded wire) | 1.5 mm <sup>2</sup> |
|--|---------------------|

### 8.1.3.10 Double ST Ethernet & IRIG-B communication module

Table. 8.1.3.10 - 440. Technical data for the double ST 100 Mbps Ethernet communication module.

|  |  |
|--|--|
| Spare part code                                | #SP-2XX-2XST   |
| Compatibility                                  | AQ 210 series models<br>AQ 250 series models<br>AQ-ONE                         |
| <b>Protocols</b>                               |  |
| Protocols                                      | IEC61850<br>DNP/TCP<br>Modbus/TCP<br>IEC104<br>FTP                             |
| <b>ST connectors</b>                           |  |
| Connector type                                 | Duplex ST connectors<br>62.5/125 µm or 50/125 µm multimode fiber<br>100BASE-FX |
| Number of connectors                           | 2  |
| Transmitter wavelength                         | 1260...1360 nm (nominal: 1310 nm)  |
| Receiver wavelength                            | 1100...1600 nm   |
| Maximum distance                               | 2 km   |
| Data transfer rate                             | 100 MB/s   |
| <b>IRIG-B Connector</b>                        |  |
| Maximum cross section (solid or stranded wire) | 1.5 mm <sup>2</sup>  |

### 8.1.3.11 Double LC (HSR/PRP) Ethernet communication module

Table. 8.1.3.11 - 441. Technical data for the double LC 100 Mbps Ethernet communication module.

|                  |  |
|------------------|--|
| Spare part code  | #SP-2XX-2LC(HSR/PRP)                                   |
| Compatibility    | AQ 210 series models<br>AQ 250 series models<br>AQ-ONE |
| <b>Protocols</b> |  |

|                       |  |
|-----------------------|--|
| Protocols             | IEC 61850<br>IEC 104<br>Modbus/TCP<br>DNP3<br>FTP          |
| Redundancy            | HSR and PRP  |
| Data transfer rate    | 100 MB/s   |
| System integration    | Can be used for system protocols and for local programming |
| <b>Ports</b>          |  |
| Number of fiber ports | 2  |
| Communication port    | LC fiber connector<br>Wavelength 1300 nm                   |
| Fiber cable           | 50/125 µm or 62.5/125 µm multimode (glass)                 |

### 8.1.3.12 Double RJ-45 (HSR/PRP) Ethernet communication module

Table. 8.1.3.12 - 442. Technical data for the double RJ-45 100 Mbps Ethernet communication module.

|                    |  |
|--------------------|--|
| Spare part code    | #SP-2XX-2RJ45(HSR/PRP)                                     |
| Compatibility      | AQ 210 series models<br>AQ 250 series models<br>AQ-ONE     |
| <b>Features</b>    |  |
| Protocols          | IEC 61850<br>IEC 104<br>Modbus/TCP<br>DNP3<br>FTP          |
| Redundancy         | HSR and PRP  |
| Data transfer rate | 100 MB/s   |
| System integration | Can be used for system protocols and for local programming |
| <b>Ports</b>       |  |
| Number of ports    | 2  |
| Communication port | Copper Ethernet RJ-45                                      |

### 8.1.3.13 RS-232 & serial fiber communication module

Table. 8.1.3.13 - 443. Technical data for the RS-232 & serial fiber communication module.

|                    |               |
|--------------------|---------------|
| PP Spare part code | #SP-2XX-232PP |
|--------------------|---------------|

|  |  |
|--|--|
| PG Spare part code                             | #SP-2XX-232PG  |
| GP Spare part code                             | #SP-2XX-232GP  |
| GG Spare part code                             | #SP-2XX-232GG  |
| Compatibility                                  | AQ 210 series models<br>AQ 250 series models<br>AQ-ONE   |
| <b>Serial fiber connections</b>                |  |
| Connection types                               | <ul style="list-style-type: none"> <li>• Plastic - Plastic</li> <li>• Plastic - Glass</li> <li>• Glass - Plastic</li> <li>• Glass - Glass</li> </ul> |
| Wavelength (plastic)                           | 660 nm   |
| Wavelength (glass)                             | 820 nm   |
| Cable type                                     | 1 mm plastic fiber   |
| <b>RS-232 terminal block connections</b>       |  |
| Maximum cross section (solid or stranded wire) | 1.5 mm <sup>2</sup>  |

## 8.1.4 Display

Table. 8.1.4 - 444. Technical data for the HMI TFT display.

|                                  |                                    |
|----------------------------------|------------------------------------|
| <b>General information</b>       |                                    |
| Spare part code                  | #SP-200-DISP                       |
| Compatibility                    | AQ-250 series models               |
| <b>Dimensions and resolution</b> |                                    |
| Number of dots/resolution        | 800 x 480                          |
| Size                             | 154.08 × 85.92 mm (6.06 × 3.38 in) |
| <b>Display</b>                   |                                    |
| Type of display                  | TFT                                |
| Color                            | RGB color                          |

## 8.2 Functions

### 8.2.1 Protection functions

#### 8.2.1.1 Non-directional overcurrent protection ( $I>$ ; 50/51)

Table. 8.2.1.1 - 445. Technical data for the non-directional overcurrent function.

| Measurement inputs  |  |
|---|--|
| Current inputs  | Phase current inputs: $I_{L1}$ (A), $I_{L2}$ (B), $I_{L3}$ (C)   |
| Current input magnitudes  | RMS phase currents<br>TRMS phase currents<br>Peak-to-peak phase currents   |
| Pick-up   |  |
| Pick-up current setting   | $0.10 \dots 50.00 \times I_n$ , setting step $0.01 \times I_n$   |
| Inrush 2nd harmonic blocking  | $0.10 \dots 50.00 \% I_{fund}$ , setting step $0.01 \% I_{fund}$   |
| Inaccuracy:<br>- Current<br>- 2 <sup>nd</sup> harmonic blocking   | $\pm 0.5 \% I_{set}$ or $\pm 15 \text{ mA}$ ( $0.10 \dots 4.0 \times I_{set}$ )<br>$\pm 1.0 \%$ -unit of the 2 <sup>nd</sup> harmonic setting      |
| Operation time  |  |
| Definite time function operating time setting   | $0.000 \dots 1800.000 \text{ s}$ , setting step $0.005 \text{ s}$  |
| Inaccuracy:<br>- Definite time: $I_m/I_{set}$ ratio > 3<br>- Definite time: $I_m/I_{set}$ ratio = $1.05 \dots 3$                      | $\pm 1.0 \%$ or $\pm 20 \text{ ms}$<br>$\pm 1.0 \%$ or $\pm 30 \text{ ms}$   |
| IDMT setting parameters:<br>- k Time dial setting for IDMT<br>- A IDMT constant<br>- B IDMT constant<br>- C IDMT constant             | $0.01 \dots 25.00$ , step $0.01$<br>$0 \dots 250.0000$ , step $0.0001$<br>$0 \dots 250.0000$ , step $0.0001$<br>$0 \dots 250.0000$ , step $0.0001$ |
| Inaccuracy:<br>- IDMT operating time<br>- IDMT minimum operating time   | $\pm 1.5 \%$ or $\pm 20 \text{ ms}$<br>$\pm 20 \text{ ms}$   |
| Retardation time (overshoot)  | <30 ms   |
| Instant operation time  |  |
| Start time and instant operation time (trip):<br>- $I_m/I_{set}$ ratio = 2<br>- $I_m/I_{set}$ ratio = 5<br>- $I_m/I_{set}$ ratio = 10 | Typically 25 ms<br>Typically 16 ms<br>Typically 12 ms  |
| Reset   |  |
| Reset ratio   | 97 % of the pick-up current setting  |
| Reset time setting<br>Inaccuracy: Reset time  | $0.000 \dots 150.000 \text{ s}$ , step $0.005 \text{ s}$<br>$\pm 1.0 \%$ or $\pm 50 \text{ ms}$  |

|                                       |        |
|---------------------------------------|--------|
| Instant reset time and start-up reset | <50 ms |
|---------------------------------------|--------|



**NOTICE!**

The release delay does not apply to phase-specific tripping!

## 8.2.1.2 Non-directional earth fault protection ( $I_{0>}$ ; 50N/51N)

Table. 8.2.1.2 - 446. Technical data for the non-directional earth fault function.

| Measurement inputs   |  |
|--|--|
| Current input (selectable)   | Residual current channel I <sub>01</sub> (Coarse)<br>Residual current channel I <sub>02</sub> (Fine)<br>Calculated residual current: I <sub>L1</sub> (A), I <sub>L2</sub> (B), I <sub>L3</sub> (C)                           |
| Current input magnitudes   | RMS residual current (I <sub>01</sub> , I <sub>02</sub> or calculated I <sub>0</sub> )<br>TRMS residual current (I <sub>01</sub> or I <sub>02</sub> )<br>Peak-to-peak residual current (I <sub>01</sub> or I <sub>02</sub> ) |
| Pick-up  |  |
| Used magnitude   | Measured residual current I <sub>01</sub> (1 A)<br>Measured residual current I <sub>02</sub> (0.2 A)<br>Calculated residual current I <sub>0Calc</sub> (5 A)   |
| Pick-up current setting  | 0.0001...40.00 × I <sub>n</sub> , setting step 0.0001 × I <sub>n</sub>   |
| Inaccuracy:<br>- Starting I <sub>01</sub> (1 A)<br>- Starting I <sub>02</sub> (0.2 A)<br>- Starting I <sub>0Calc</sub> (5 A)                             | ±0.5 %I <sub>0set</sub> or ±3 mA (0.005...10.0 × I <sub>set</sub> )<br>±1.5 %I <sub>0set</sub> or ±1.0 mA (0.005...25.0 × I <sub>set</sub> )<br>±1.0 %I <sub>0set</sub> or ±15 mA (0.005...4.0 × I <sub>set</sub> )          |
| Operating time   |  |
| Definite time function operating time setting  | 0.000...1800.000 s, setting step 0.005 s   |
| Inaccuracy:<br>- Definite time: I <sub>m</sub> /I <sub>set</sub> ratio > 3<br>- Definite time: I <sub>m</sub> /I <sub>set</sub> ratio = 1.05...3         | ±1.0 % or ±20 ms<br>±1.0 % or ±30 ms   |
| IDMT setting parameters:<br>- k Time dial setting for IDMT<br>- A, B, C IDMT constants   | 0.01...25.00, step 0.01<br>0...250.0000, step 0.0001   |
| Inaccuracy:<br>- IDMT operating time<br>- IDMT minimum operating time  | ±1.5 % or ±20 ms<br>±20 ms   |
| Retardation time (overshoot)   | <30 ms   |
| Instant operation time   |  |
| Start time and instant operation time (trip):<br>- I <sub>m</sub> /I <sub>set</sub> ratio > 3.5<br>- I <sub>m</sub> /I <sub>set</sub> ratio = 1.05...3.5 | <50 ms (typically 35 ms)<br><55 ms   |
| Reset  |  |

|  |   |
|--|---|
| Reset ratio                                  | 97 % of the pick-up current setting                 |
| Reset time setting<br>Inaccuracy: Reset time | 0.000...150.000 s, step 0.005 s<br>±1.0 % or ±50 ms |
| Instant reset time and start-up reset        | <50 ms  |

**NOTICE!**

The operation and reset time accuracy does **not** apply when the measured secondary current in I02 is 1...20 mA. The pick-up is tuned to be more sensitive, and the operation times vary because of this.

### 8.2.1.3 Directional overcurrent protection ( $I_{dir}$ ; 67)

Table. 8.2.1.3 - 447. Technical data for the directional overcurrent function.

| Input signals   |  |
|---|--|
| Current inputs  | Phase current inputs: $I_{L1}$ (A), $I_{L2}$ (B), $I_{L3}$ (C)   |
| Current input magnitudes  | RMS phase currents<br>TRMS phase currents<br>Peak-to-peak phase currents                                       |
| Current input calculations  | Positive sequence current angle  |
| Voltage inputs  | $U_{L1}$ , $U_{L2}$ , $U_{L3}$<br>$U_{L12}$ , $U_{L23}$ , $U_{L31}$ + $U_0$                                    |
| Voltage input calculations  | Positive sequence voltage angle  |
| Pick-up   |  |
| Characteristic direction  | Directional, non-directional   |
| Operating sector center   | -180.0...180.0 deg, setting step 0.1 deg   |
| Operating sector size (+/-)   | 1.00...170.00 deg, setting step 0.10 deg   |
| Pick-up current setting   | 0.10...40.00 × $I_n$ , setting step 0.01 × $I_n$   |
| Inaccuracy:<br>- Current<br>- $U_{1/I1}$ angle ( $U > 15$ V)<br>- $U_{1/I1}$ angle ( $U = 1...15$ V)                      | ±0.5 % $I_{set}$ or ±15 mA (0.10...4.0 × $I_{set}$ )<br>±0.20°<br>±1.5°  |
| Operation time  |  |
| Definite time function operating time setting   | 0.000...1800.000 s, setting step 0.005 s   |
| Inaccuracy:<br>- Definite time: $I_m/I_{set}$ ratio > 3<br>- Definite time: $I_m/I_{set}$ ratio = 1.05...3                | ±1.0 % or ±20 ms<br>±1.0 % or ±35 ms   |
| IDMT setting parameters:<br>- k Time dial setting for IDMT<br>- A IDMT constant<br>- B IDMT constant<br>- C IDMT constant | 0.01...25.00, step 0.01<br>0...250.0000, step 0.0001<br>0...250.0000, step 0.0001<br>0...250.0000, step 0.0001 |

|  |  |
|--|--|
| Inaccuracy:<br>- IDMT operating time<br>- IDMT minimum operating time  | $\pm 1.5\%$ or $\pm 20$ ms<br>$\pm 20$ ms                      |
| <b>Instant operation time</b>  |  |
| Start time and instant operation time (trip):<br>- $I_m/I_{set}$ ratio $> 3$<br>- $I_m/I_{set}$ ratio = 1.05...3 | $< 40$ ms (typically 30 ms)<br>$< 50$ ms                       |
| <b>Reset</b>   |  |
| Reset ratio:<br>- Current<br>- $U_1/I_1$ angle   | 97 % of the pick-up current setting<br>$2.0^\circ$             |
| Reset time setting<br>Inaccuracy: Reset time   | 0.000... 150.000 s, step 0.005 s<br>$\pm 1.0\%$ or $\pm 50$ ms |
| Instant reset time and start-up reset  | $< 50$ ms  |



**NOTICE!**

The minimum voltage for direction solving is 1.0 V secondary. During three-phase short-circuits the angle memory is active for 0.5 seconds in case the voltage drops below 1.0 V.

### 8.2.1.4 Directional earth fault protection ( $I_{0dir}>$ ; 67N/32N)

Table. 8.2.1.4 - 448. Technical data for the directional earth fault function.

|   |  |
|---|--|
| <b>Measurement inputs</b>   |  |
| Current input (selectable)  | Residual current channel $I_{01}$ (Coarse)<br>Residual current channel $I_{02}$ (Fine)<br>Calculated residual current: $I_{L1}$ (A), $I_{L2}$ (B), $I_{L3}$ (C)              |
| Current input magnitudes  | RMS residual current ( $I_{01}$ , $I_{02}$ or calculated $I_0$ )<br>TRMS residual current ( $I_{01}$ or $I_{02}$ )<br>Peak-to-peak residual current ( $I_{01}$ or $I_{02}$ ) |
| Voltage input (selectable)  | Residual voltage from $U_3$ or $U_4$ voltage channel<br>Residual voltage calculated from $U_{L1}$ , $U_{L2}$ , $U_{L3}$  |
| Voltage input magnitudes  | RMS residual voltage $U_0$<br>Calculated RMS residual voltage $U_0$  |
| <b>Pick-up</b>  |  |
| Characteristic direction  | Unearthed (Varmetric $90^\circ$ )<br>Petersen coil GND (Wattmetric $180^\circ$ )<br><u>Earthed</u> (Adjustable sector)   |
| When the <u>earthed</u> mode is active:<br>- Tripping area center<br>- Tripping area size (+/-) | 0.00...360.00 deg, setting step 0.10 deg<br>45.00...135.00 deg, setting step 0.10 deg  |
| Pick-up current setting<br>Pick-up voltage setting  | 0.005...40.00 $\times I_n$ , setting step 0.001 $\times I_n$<br>1.00...75.00 % $U_{0n}$ , setting step 0.01 % $U_{0n}$   |

|   |  |
|---|--|
| Inaccuracy:<br>- Starting I01 (1 A)<br>- Starting I02 (0.2 A)<br>- Starting I0Calc (5 A)<br>- Voltage U0 and U0Calc<br>- U0/I0 angle (U > 15 V)<br>- U0/I0 angle (U = 1...15 V) | $\pm 0.5 \% I_{0\text{set}}$ or $\pm 3 \text{ mA}$ ( $0.005 \dots 10.0 \times I_{\text{set}}$ )<br>$\pm 1.5 \% I_{0\text{set}}$ or $\pm 1.0 \text{ mA}$ ( $0.005 \dots 25.0 \times I_{\text{set}}$ )<br>$\pm 1.5 \% I_{0\text{set}}$ or $\pm 15 \text{ mA}$ ( $0.005 \dots 4.0 \times I_{\text{set}}$ )<br>$\pm 1.0 \% U_{0\text{set}}$ or $\pm 30 \text{ mV}$<br>$\pm 0.2^\circ$ (I0Calc $\pm 1.0^\circ$ )<br>$\pm 1.0^\circ$ |
| <b>Operation time</b>   |  |
| Definite time function operating time setting   | 0.000...1800.000 s, setting step 0.005 s   |
| Inaccuracy:<br>- Definite time ( $I_m/I_{\text{set}}$ ratio 1.05→)  | $\pm 1.0 \%$ or $\pm 45 \text{ ms}$  |
| IDMT setting parameters:<br>- k Time dial setting for IDMT<br>- A IDMT constant<br>- B IDMT constant<br>- C IDMT constant   | 0.01...25.00, step 0.01<br>0...250.0000, step 0.0001<br>0...250.0000, step 0.0001<br>0...250.0000, step 0.0001   |
| Inaccuracy:<br>- IDMT operating time<br>- IDMT minimum operating time   | $\pm 1.5 \%$ or $\pm 25 \text{ ms}$<br>$\pm 20 \text{ ms}$   |
| <b>Instant operation time</b>   |  |
| Start time and instant operation time (trip):<br>- $I_m/I_{\text{set}}$ ratio > 3<br>- $I_m/I_{\text{set}}$ ratio = 1.05...3  | <55 ms (typically 45 ms)<br><65 ms   |
| <b>Reset</b>  |  |
| Current and voltage reset<br>U0/I0 angle  | 97 % of the pick-up current and voltage setting<br>$2.0^\circ$   |
| Reset time setting<br>Inaccuracy: Reset time  | 0.000...150.000 s, step 0.005 s<br>$\pm 1.0 \%$ or $\pm 45 \text{ ms}$   |
| Instant reset time and start-up reset   | <50 ms   |

### 8.2.1.5 Negative sequence overcurrent/ phase current reversal/ current unbalance protection ( $I_{2>}$ ; 46/46R/46L)

Table. 8.2.1.5 - 449. Technical data for the current unbalance function.

|                            |  |
|----------------------------|--|
| <b>Measurement inputs</b>  |  |
| Current inputs             | Phase current inputs: $I_{L1}$ (A), $I_{L2}$ (B), $I_{L3}$ (C)               |
| Current input calculations | Positive sequence current ( $I_1$ )<br>Negative sequence current ( $I_2$ )   |
| <b>Pick-up</b>             |  |
| Used magnitude             | Negative sequence component $I_{2\text{pu}}$<br>Relative unbalance $I_2/I_1$ |

|   |   |
|---|---|
| Pick-up setting   | 0.01...40.00 × I <sub>N</sub> , setting step 0.01 × I <sub>N</sub> (I2pu)<br>1.00...200.00 %, setting step 0.01 % (I2/I1) |
| Minimum phase current (at least one phase above)  | 0.01...2.00 × I <sub>N</sub> , setting step 0.01 × I <sub>N</sub>   |
| Inaccuracy:<br>- Starting I2pu<br>- Starting I2/I1  | ±1.0 %-unit or ±100 mA (0.10...4.0 × I <sub>N</sub> )<br>±1.0 %-unit or ±100 mA (0.10...4.0 × I <sub>N</sub> )            |
| <b>Operating time</b>   |   |
| Definite time function operating time setting   | 0.000...1800.000 s, setting step 0.005 s  |
| Inaccuracy:<br>- Definite time (I <sub>m</sub> /I <sub>set</sub> ratio > 1.05)  | ±1.5 % or ±60 ms  |
| IDMT setting parameters:<br>- k Time dial setting for IDMT<br>- A IDMT Constant<br>- B IDMT Constant<br>- C IDMT Constant | 0.01...25.00, step 0.01<br>0...250.0000, step 0.0001<br>0...250.0000, step 0.0001<br>0...250.0000, step 0.0001            |
| Inaccuracy:<br>- IDMT operating time<br>- IDMT minimum operating time   | ±2.0 % or ±30 ms<br>±20 ms  |
| Retardation time (overshoot)  | <5 ms   |
| <b>Instant operation time</b>   |   |
| Start time and instant operation time (trip):<br>- I <sub>m</sub> /I <sub>set</sub> ratio > 1.05                          | <70 ms  |
| <b>Reset</b>  |   |
| Reset ratio   | 97 % of the pick-up setting   |
| Reset time setting<br>Inaccuracy: Reset time  | 0.000...150.000 s, step 0.005 s<br>±1.5 % or ±60 ms   |
| Instant reset time and start-up reset   | <55 ms  |

### 8.2.1.6 Harmonic overcurrent protection (I<sub>h</sub>>; 50H/51H/68H)

Table. 8.2.1.6 - 450. Technical data for the harmonic overcurrent function.

|                           |   |
|---------------------------|---|
| <b>Measurement inputs</b> |   |
| Current inputs            | Phase current inputs: I <sub>L1</sub> (A), I <sub>L2</sub> (B), I <sub>L3</sub> (C)<br>Residual current channel I <sub>01</sub> (Coarse)<br>Residual current channel I <sub>02</sub> (Fine)                                 |
| <b>Pick-up</b>            |   |
| Harmonic selection        | 2 <sup>nd</sup> , 3 <sup>rd</sup> , 4 <sup>th</sup> , 5 <sup>th</sup> , 6 <sup>th</sup> , 7 <sup>th</sup> , 9 <sup>th</sup> , 11 <sup>th</sup> , 13 <sup>th</sup> , 15 <sup>th</sup> , 17 <sup>th</sup> or 19 <sup>th</sup> |
| Used magnitude            | Harmonic per unit (× I <sub>N</sub> )<br>Harmonic relative (I <sub>h</sub> /I <sub>L</sub> )  |

|   |  |
|---|--|
| Pick-up setting   | 0.05...2.00 × I <sub>N</sub> , setting step 0.01 × I <sub>N</sub> (× I <sub>N</sub> )<br>5.00...200.00 %, setting step 0.01 % (I <sub>h</sub> /I <sub>L</sub> )                            |
| Inaccuracy:<br>- Starting × I <sub>N</sub><br>- Starting × I <sub>h</sub> /I <sub>L</sub>                         | <0.03 × I <sub>N</sub> (2 <sup>nd</sup> , 3 <sup>rd</sup> , 5 <sup>th</sup> )<br><0.03 × I <sub>N</sub> tolerance to I <sub>h</sub> (2 <sup>nd</sup> , 3 <sup>rd</sup> , 5 <sup>th</sup> ) |
| <b>Operation time</b>   |  |
| Definite time function operating time setting   | 0.000...1800.000 s, setting step 0.005 s   |
| Inaccuracy:<br>- Definite time (I <sub>M</sub> /I <sub>SET</sub> ratio >1.05)                                     | ±1.0 % or ±35 ms   |
| IDMT setting parameters:<br>k Time dial setting for IDMT<br>A IDMT constant<br>B IDMT constant<br>C IDMT constant | 0.01...25.00, step 0.01<br>0...250.0000, step 0.0001<br>0...250.0000, step 0.0001<br>0...250.0000, step 0.0001   |
| Inaccuracy:<br>- IDMT operating time<br>- IDMT minimum operating time   | ±1.5 % or ±20 ms<br>±20 ms   |
| <b>Instant operation time</b>   |  |
| Start time and instant operation time (trip):<br>I <sub>M</sub> /I <sub>SET</sub> ratio >1.05                     | <50 ms   |
| <b>Reset</b>  |  |
| Reset ratio   | 95 % of the pick-up setting  |
| Reset time setting<br>Inaccuracy: Reset time  | 0.000...150.000 s, step 0.005 s<br>±1.0 % or ±35 ms  |
| Instant reset time and start-up reset   | <50 ms   |

**NOTICE!**

Harmonics generally: The amplitude of the harmonic content **must** be least 0.02 × I<sub>N</sub> when the relative mode (I<sub>h</sub>/I<sub>L</sub>) is used!



Blocking: To achieve fast activation for blocking purposes with the harmonic overcurrent stage, note that the harmonic stage may be activated by a rapid load change or fault situation. An intentional activation lasts for approximately 20 ms if a harmonic component is not present. The harmonic stage stays active if the harmonic content is above the pick-up limit.

Tripping: When using the harmonic overcurrent stage for tripping, please ensure that the operation time is set to 20 ms (DT) or longer to avoid nuisance tripping caused by the above-mentioned reasons.

### 8.2.1.7 Circuit breaker failure protection (CBFP; 50BF/52BF)

Table. 8.2.1.7 - 451. Technical data for the circuit breaker failure protection function.

#### Measurement inputs

|  |  |
|--|--|
| Current inputs   | Phase current inputs: $I_{L1}$ (A), $I_{L2}$ (B), $I_{L3}$ (C)<br>Residual current channel $I_{01}$ (Coarse)<br>Residual current channel $I_{02}$ (Fine)   |
| Current input magnitudes   | RMS phase currents<br>RMS residual current ( $I_{01}$ , $I_{02}$ or calculated $I_0$ )   |
| <b>Pick-up</b>   |  |
| Monitored signals  | Digital input status, digital output status, logical signals   |
| Pick-up current setting:<br>- $I_{L1} \dots I_{L3}$<br>- $I_{01}$ , $I_{02}$ , $I_{0Calc}$   | $0.10 \dots 40.00 \times I_N$ , setting step $0.01 \times I_N$<br>$0.005 \dots 40.00 \times I_N$ , setting step $0.005 \times I_N$   |
| Inaccuracy:<br>- Starting phase current (5A)<br>- Starting $I_{01}$ (1 A)<br>- Starting $I_{02}$ (0.2 A)<br>- Starting $I_{0Calc}$ (5 A) | $\pm 0.5 \% I_{SET}$ or $\pm 15$ mA ( $0.10 \dots 4.0 \times I_{SET}$ )<br>$\pm 0.5 \% I_{0SET}$ or $\pm 3$ mA ( $0.005 \dots 10.0 \times I_{SET}$ )<br>$\pm 1.5 \% I_{0SET}$ or $\pm 1.0$ mA ( $0.005 \dots 25.0 \times I_{SET}$ )<br>$\pm 1.0 \% I_{0SET}$ or $\pm 15$ mA ( $0.005 \dots 4.0 \times I_{SET}$ ) |
| <b>Operation time</b>  |  |
| Definite time function operating time setting  | $0.050 \dots 1800.000$ s, setting step $0.005$ s   |
| Inaccuracy:<br>- Current criteria ( $I_m/I_{SET}$ ratio $1.05 \rightarrow$ )<br>- DO or DI only  | $\pm 1.0$ % or $\pm 55$ ms<br>$\pm 15$ ms  |
| <b>Reset</b>   |  |
| Reset ratio  | 97 % of the pick-up current setting  |
| Reset time   | <50 ms   |

## 8.2.1.8 Overvoltage protection ( $U >$ ; 59)

Table. 8.2.1.8 - 452. Technical data for the overvoltage function.

|   |  |
|---|--|
| <b>Measurement inputs</b>                     |  |
| Voltage inputs                                | $U_{L1}$ , $U_{L2}$ , $U_{L3}$<br>$U_{L12}$ , $U_{L23}$ , $U_{L31}$ (+ $U_0$ ) |
| Voltage input magnitudes                      | RMS line-to-line or line-to-neutral voltages                                   |
| <b>Pick-up</b>                                |  |
| Pick-up terms                                 | 1 voltage<br>2 voltages<br>3 voltages  |
| Pick-up setting                               | $1.00 \dots 250.00 \% U_N$ , setting step $0.01 \% U_N$                        |
| Inaccuracy:<br>- Voltage                      | $\pm 1.5 \% U_{SET}$   |
| <b>Operating time</b>                         |  |
| Definite time function operating time setting | $0.000 \dots 1800.000$ s, setting step $0.005$ s                               |

|   |   |
|---|---|
| Inaccuracy:<br>- Definite time ( $U_M/U_{SET}$ ratio 1.05→)                     | $\pm 1.0\%$ or $\pm 35$ ms                                    |
| IDMT setting parameters:<br>- k Time dial setting for IDMT<br>- IDMT Multiplier | 0.01...60.00, step 0.01<br>0...25.00, step 0.01               |
| Inaccuracy:<br>- IDMT operating time<br>- IDMT minimum operating time           | $\pm 1.5\%$ or $\pm 20$ ms<br>$\pm 20$ ms                     |
| <b>Instant operation time</b>   |   |
| Start time and instant operation time (trip):<br>- $U_M/U_{SET}$ ratio 1.05→    | <50 ms  |
| <b>Reset</b>  |   |
| Reset ratio   | 97 % of the pick-up voltage setting                           |
| Reset time setting<br>Inaccuracy: Reset time                                    | 0.000...150.000 s, step 0.005 s<br>$\pm 1.0\%$ or $\pm 45$ ms |
| Instant reset time and start-up reset   | <50 ms  |

### 8.2.1.9 Undervoltage protection ( $U < 27$ )

Table. 8.2.1.9 - 453. Technical data for the undervoltage function.

|   |  |
|---|--|
| <b>Measurement inputs</b>                                   |  |
| Voltage inputs  | $U_{L1}, U_{L2}, U_{L3}$<br>$U_{L12}, U_{L23}, U_{L31}$ (+ $U_0$ ) |
| Voltage input magnitudes                                    | RMS line-to-line or line-to-neutral voltages                       |
| <b>Pick-up</b>  |  |
| Pick-up terms   | 1 voltage<br>2 voltages<br>3 voltages                              |
| Pick-up setting   | 0.00...120.00 % $U_N$ , setting step 0.01 % $U_N$                  |
| Inaccuracy:<br>- Voltage                                    | $\pm 1.5\%$ $U_{SET}$ or $\pm 30$ mV                               |
| <b>Low voltage block</b>                                    |  |
| Pick-up setting   | 0.00...80.00 % $U_N$ , setting step 0.01 % $U_N$                   |
| Inaccuracy:<br>- Voltage                                    | $\pm 1.5\%$ $U_{SET}$ or $\pm 30$ mV                               |
| <b>Operation time</b>                                       |  |
| Definite time function operating time setting               | 0.000...1800.000 s, setting step 0.005 s                           |
| Inaccuracy:<br>- Definite time ( $U_M/U_{SET}$ ratio 1.05→) | $\pm 1.0\%$ or $\pm 35$ ms   |

|   |   |
|---|---|
| IDMT setting parameters:<br>- k Time dial setting for IDMT<br>- IDMT Multiplier | 0.01...60.00, step 0.01<br>0...25.00, step 0.01     |
| Inaccuracy:<br>- IDMT operating time<br>- IDMT minimum operating time           | ±1.5 % or ±20 ms<br>±20 ms                          |
| <b>Instant operation time</b>   |   |
| Start time and instant operation time (trip):<br>- $U_M/U_{SET}$ ratio 1.05→    | <65 ms  |
| Retardation time (overshoot)  | <30 ms  |
| <b>Reset</b>  |   |
| Reset ratio   | 103 % of the pick-up voltage setting                |
| Reset time setting<br>Inaccuracy: Reset time                                    | 0.000...150.000 s, step 0.005 s<br>±1.0 % or ±45 ms |
| Instant reset time and start-up reset   | <50 ms  |



**NOTICE!**

The low-voltage block is not in use when its pick-up setting is set to 0 %. The undervoltage function trip signal is active when the LV block is disabled, and the device has no voltage injection.



**NOTICE!**

After the low voltage blocking condition, the undervoltage stage does not trip unless the voltage exceeds the pick-up setting first.

### 8.2.1.10 Neutral overvoltage protection ( $U_0 >$ ; 59N)

Table. 8.2.1.10 - 454. Technical data for the neutral overvoltage function.

|   |   |
|---|---|
| <b>Measurement inputs</b>                               |   |
| Voltage input (selectable)                              | Residual voltage from U3 or U4 voltage channel<br>Residual voltage calculated from $U_{L1}$ , $U_{L2}$ , $U_{L3}$ |
| Voltage input magnitudes                                | RMS residual voltage $U_0$<br>Calculated RMS residual voltage $U_0$   |
| <b>Pick-up</b>  |   |
| Pick-up voltage setting                                 | 1.00...50.00 % $U_{0N}$ , setting step $0.01 \times I_N$  |
| Inaccuracy:<br>- Voltage $U_0$<br>- Voltage $U_{0Calc}$ | ±1.5 % $U_{0SET}$ or ±30 mV<br>±150 mV  |
| <b>Operation time</b>                                   |   |
| Definite time function operating time setting           | 0.000...1800.000 s, setting step 0.005 s  |

|  |   |
|--|---|
| Inaccuracy:<br>- Definite time ( $U_{0M}/U_{0SET}$ ratio 1.05→)                  | $\pm 1.0\%$ or $\pm 45$ ms                                      |
| IDMT setting parameters:<br>- k Time dial setting for IDMT<br>- IDMT Multiplier  | 0.01...60.00, step 0.01<br>0...25.00, step 0.01                 |
| Inaccuracy:<br>- IDMT operating time<br>- IDMT minimum operating time            | $\pm 1.5\%$ or $\pm 20$ ms<br>$\pm 20$ ms                       |
| <b>Instant operation time</b>  |   |
| Start time and instant operation time (trip):<br>- $U_{0M}/U_{0SET}$ ratio 1.05→ | <50 ms  |
| <b>Reset</b>   |   |
| Reset ratio  | 97 % of the pick-up voltage setting                             |
| Reset time setting<br>Inaccuracy: Reset time                                     | 0.000 ... 150.000 s, step 0.005 s<br>$\pm 1.0\%$ or $\pm 50$ ms |
| Instant reset time and start-up reset  | <50 ms  |

### 8.2.1.11 Sequence voltage protection ( $U_1/U_2 > / < ; 47/27P/59NP$ )

Table. 8.2.1.11 - 455. Technical data for the sequence voltage function.

|   |  |
|---|--|
| <b>Measurement inputs</b>                                 |  |
| Voltage inputs  | $U_{L1}, U_{L2}, U_{L3}$<br>$U_{L12}, U_{L23}, U_{L31}$ (+ $U_0$ ) |
| Voltage input calculations                                | Positive sequence voltage (I1)<br>Negative sequence voltage (I2)   |
| <b>Pick-up</b>  |  |
| Pick-up setting   | 5.00...150.00 % $U_N$ , setting step 0.01 % $U_N$                  |
| Inaccuracy:<br>- Voltage                                  | $\pm 1.5\%$ $U_{SET}$ or $\pm 30$ mV                               |
| <b>Low voltage block</b>                                  |  |
| Pick-up setting   | 1.00...80.00 % $U_N$ , setting step 0.01 % $U_N$                   |
| Inaccuracy:<br>-Voltage                                   | $\pm 1.5\%$ $U_{SET}$ or $\pm 30$ mV                               |
| <b>Operation time</b>                                     |  |
| Definite time function operating time setting             | 0.000...1800.000 s, setting step 0.005 s                           |
| Inaccuracy<br>-Definite Time ( $U_M/U_{SET}$ ratio 1.05→) | $\pm 1.0\%$ or $\pm 35$ ms   |

|  |   |
|--|---|
| IDMT setting parameters:<br>- k Time dial setting for IDMT<br>- IDMT Multiplier    | 0.01...60.00, step 0.01<br>0...25.00, step 0.01     |
| Inaccuracy:<br>- IDMT operating time<br>- IDMT minimum operating time              | ±1.5 % or ±20 ms<br>±20 ms                          |
| <b>Instant operation time</b>  |   |
| Start time and instant operation time (trip):<br>- $U_M/U_{SET}$ ratio <0.95/1.05→ | <65 ms  |
| <b>Reset</b>   |   |
| Reset ratio  | 97 or 103 % of the pick-up voltage setting          |
| Reset time setting<br>Inaccuracy: Reset time                                       | 0.000...150.000 s, step 0.005 s<br>±1.0 % or ±35 ms |
| Instant reset time and start-up reset  | <50 ms  |

## 8.2.1.12 Overfrequency and underfrequency protection ( $f > / <$ ; 81O/81U)

Table. 8.2.1.12 - 456. Technical data for the overfrequency and underfrequency function.

|  |   |
|--|---|
| <b>Input signals</b>   |   |
| Sampling mode  | Fixed<br>Tracking   |
| Frequency reference 1<br>Frequency reference 2<br>Frequency reference 3  | CT11L1, CT21L1, VT1U1, VT2U1<br>CT11L2, CT21L2, VT1U2, VT2U2<br>CT11L3, CT21L3, VT1U3, VT2U3                      |
| <b>Pick-up</b>   |   |
| $f >$ pick-up setting<br>$f <$ pick-up setting   | 10.00...70.00 Hz, setting step 0.01 Hz<br>7.00...65.00 Hz, setting step 0.01 Hz                                   |
| Inaccuracy (sampling mode):<br>- Fixed<br>- Tracking   | ±20 mHz (50/60 Hz fixed frequency)<br>±20 mHz ( $U > 30$ V secondary)<br>±20 mHz ( $I > 30$ % of rated secondary) |
| <b>Operation time</b>  |   |
| Definite time function operating time setting  | 0.000...1800.000 s, setting step 0.005 s  |
| Inaccuracy:<br>- Definite time ( $I_M/I_{SET}$ ratio +/- 50 mHz)   | ±1.5 % or ±50 ms (max. step size: 100 mHz)  |
| <b>Instant operation time</b>  |   |
| Start time and instant operation time (trip):<br>- $I_M/I_{SET}$ ratio +/- 50 mHz (Fixed)<br>- $I_M/I_{SET}$ ratio +/- 50 mHz (Tracking) | <70 ms (max. step size: 100 mHz)<br><3 cycles or <60 ms (max. step size: 100 mHz)                                 |
| <b>Reset</b>   |   |

|   |  |
|---|--|
| Reset ratio   | 0.020 Hz   |
| Instant reset time and start-up reset:<br>- $I_M/I_{SET}$ ratio +/- 50 mHz (Fixed)<br>- $I_M/I_{SET}$ ratio +/- 50 mHz (Tracking) | <110 ms (max. step size: 100 mHz)<br><3 cycles or <70 ms (max. step size: 100 mHz) |

**NOTICE!**

Measuring frequency requires that the secondary voltage exceeds 2 volts, or the current exceeds 0.25 amperes (peak-to-peak).

**NOTICE!**

The frequency is measured two seconds after a signal is received.

### 8.2.1.13 Rate-of-change of frequency protection ( $df/dt$ > / < ; 81R)

Table. 8.2.1.13 - 457. Technical data for the rate-of-change of frequency function.

| Input signals   |  |
|---|--|
| Sampling mode   | Fixed<br>Tracking  |
| Frequency reference 1<br>Frequency reference 2<br>Frequency reference 3 | CT1IL1, CT2IL1, VT1U1, VT2U1<br>CT1IL2, CT2IL2, VT1U2, VT2U2<br>CT1IL3, CT2IL3, VT1U3, VT2U3 |
| Pick-up   |  |
| $df/dt$ > / < pick-up setting   | 0.15...1.00 Hz/s, setting step 0.01 Hz   |
| $f$ > limit   | 10.00...70.00 Hz, setting step 0.01 Hz   |
| $f$ < limit   | 7.00...65.00 Hz, setting step 0.01 Hz  |
| Pick-up inaccuracy  |  |
| - $df/dt$   | $\pm 5.0 \% I_{SET}$ or $\pm 20$ mHz/s   |
| - frequency   | $\pm 15$ mHz ( $U > 30$ V secondary)<br>$\pm 20$ mHz ( $I > 30$ % of rated secondary)        |
| Operation time  |  |
| Definite time function operating time setting                           | 0.000...1800.000 s, setting step 0.005 s   |
| Inaccuracy:<br>- Definite time ( $I_M/I_{SET}$ ratio +/- 50 mHz)        | $\pm 1.5$ % or $\pm 110$ ms (max. step size: 100 mHz)  |
| Start time and instant operation time (trip):                           |  |
| - $f_M/f_{SET}$ ratio +/- 20 mHz (overreach)                            | <200 ms  |
| - $f_M/f_{SET}$ ratio +/- 200 mHz (overreach)                           | <90 ms   |
| Reset   |  |
| $f$ < and $f$ > frequency limit   | $\pm 0.020$ Hz   |

|  |                                   |
|--|-----------------------------------|
| df/dt  | ±10.0 % of pick-up or 50 mHz/s    |
| Instant reset time and start-up reset:<br>- fM/fSET ratio +/- 50 mHz | <325 ms (max. step size: 100 mHz) |



**NOTICE!**

Frequency is measured two seconds after a signal is received.

### 8.2.1.14 Power protection (P, Q, S) >/< 32)

Table. 8.2.1.14 - 458. Technical data for the power protection function.

| Measurement inputs  |   |
|---|---|
| Current inputs  | Phase current inputs: I <sub>L1</sub> (A), I <sub>L2</sub> (B), I <sub>L3</sub> (C)   |
| Voltage inputs  | U <sub>L1</sub> , U <sub>L2</sub> , U <sub>L3</sub><br>U <sub>L12</sub> , U <sub>L23</sub> , U <sub>L31</sub> (+ U <sub>0</sub> ) |
| Calculated measurements   | Three-phase active, reactive or apparent power (P, Q or S) value based on the chosen or set nominal amplitude.                    |
| Pick-up   |   |
| Comparator selection  | > or <  |
| > or <  | -500.000...500.000 %/MVA <sub>N</sub> , setting step 0.005 %/MVA <sub>N</sub>   |
| Inaccuracy:<br>- Active, reactive, or apparent power  | Typically <1.0 %P <sub>SET</sub>  |
| Operation time  |   |
| Definite time function operating time setting   | 0.000...1800.000 s, setting step 0.005 s  |
| Inaccuracy:<br>- Definite time (P <sub>M</sub> /P <sub>SET</sub> ratio 1.05→)                       | ±1.0 % or ±35 ms  |
| Instant operation time  |   |
| Start time and instant operation time (trip):<br>- PQS <sub>M</sub> /PQS <sub>SET</sub> ratio 1.05→ | <40 ms  |
| Reset   |   |
| Reset ratio   | 97 or 103 %P <sub>SET</sub>   |
| Instant reset time and start-up reset   | <40 ms  |

### 8.2.1.15 Transformer thermal overload protection (TT>; 49T)

Table. 8.2.1.15 - 459. Technical data for the transformer thermal overload protection function.

| Measurement inputs  |  |
|---|--|
| Current inputs  | Phase current inputs: $I_{L1}$ (A), $I_{L2}$ (B), $I_{L3}$ (C)   |
| Current input magnitudes  | TRMS phase currents (up to the 31 <sup>st</sup> harmonic)  |
| Setting specifications  |  |
| Time constants $\tau$   | 1 heating, 1 cooling   |
| Time constant value   | 0.0...500.00 min, step 0.1 min   |
| Service factor (maximum overloading)  | $0.01...5.00 \times I_N$ , step $0.01 \times I_N$  |
| Thermal model biasing   | - Ambient temperature (Set $-60.0...500.0$ deg, step 0.1 deg, and RTD)<br>- Negative sequence current                        |
| Thermal replica temperature estimates   | Selectable between °C and °F   |
| Outputs   |  |
| - Alarm 1<br>- Alarm 2<br>- Thermal trip<br>- Trip delay<br>- Restart inhibit | 0...150 %, step 1 %<br>0...150 %, step 1 %<br>0...150 %, step 1 %<br>0.000...3600.000 s, step 0.005 s<br>0...150 %, step 1 % |
| Inaccuracy  |  |
| - Starting<br>- Operating time  | $\pm 0.5$ % of the set pick-up value<br>$\pm 5$ % or $\pm 500$ ms  |

### 8.2.1.16 Underimpedance protection (Z<; 21U)

Table. 8.2.1.16 - 460. Technical data for the underimpedance function.

| Measurement inputs                     |  |
|--|--|
| Current inputs                         | Phase current inputs: $I_{L1}$ (A), $I_{L2}$ (B), $I_{L3}$ (C)                         |
| Voltage inputs                         | $U_{L1}$ , $U_{L2}$ , $U_{L3}$<br>$U_{L12}$ , $U_{L23}$ , $U_{L31} + U_0$              |
| Calculated impedances                  | Phase-to-phase impedances<br>Phase-to-ground impedances<br>Positive sequence impedance |
| Pick-up                                |  |
| Pick-up setting                        | 0.1...150.0 $\Omega$ , setting step 0.1 $\Omega$                                       |
| Inaccuracy:<br>- Impedance calculation | Typically $<1.0 \% Z_{SET}$  |
| Operation time                         |  |

|  |   |
|--|---|
| Definite time function operating time setting                                | 0.000...1800.000 s, setting step 0.005 s                      |
| Inaccuracy:<br>- Definite time ( $Z_M/Z_{SET}$ ratio <0.95)                  | $\pm 1.0\%$ or $\pm 25$ ms                                    |
| <b>Instant operation time</b>  |   |
| Start time and instant operation time (trip):<br>- $Z_M/Z_{SET}$ ratio <0.95 | <45 ms  |
| <b>Reset</b>   |   |
| Reset ratio  | 103 % $Z_{SET}$   |
| Reset time setting<br>Inaccuracy: Reset time                                 | 0.000...150.000 s, step 0.005 s<br>$\pm 1.0\%$ or $\pm 25$ ms |
| Instant reset time and start-up reset  | <45 ms  |

### 8.2.1.17 Volts-per-hertz overexcitation protection ( $V/Hz$ >; 24)

Table. 8.2.1.17 - 461. Technical data for the volts-per-hertz overexcitation protection function.

|  |  |
|--|--|
| <b>Measurement inputs</b>  |  |
| Voltage input  | $U_{L1}, U_{L2}, U_{L3}$<br>$U_{L12}, U_{L23}, U_{L31}$                                      |
| Voltage input magnitude  | Maximum line-to-line voltage   |
| Frequency reference 1<br>Frequency reference 2<br>Frequency reference 3          | CT1IL1, CT2IL1, VT1U1, VT2U1<br>CT1IL2, CT2IL2, VT1U2, VT2U2<br>CT1IL3, CT2IL3, VT1U3, VT2U3 |
| <b>Pick-up</b>   |  |
| Pick-up setting  | 0.01...75.00 %, setting step 0.01 %  |
| Inaccuracy:<br>- $V/Hz$  | $\pm 1.0\%$  |
| <b>Operation time</b>  |  |
| Definite time function operating time setting                                    | 0.000...1800.000 s, setting step 0.005 s   |
| Inaccuracy:<br>- Definite time ( $VHZ_M/VHZ_{SET}$ ratio 1.05)                   | $\pm 1.0\%$ or $\pm 25$ ms   |
| <b>Instant operation time</b>  |  |
| Start time and instant operation time (trip):<br>- $VHZ_M/VHZ_{SET}$ ratio 1.05) | <40 ms   |
| <b>Reset</b>   |  |
| Reset ratio  | 97 % of the pick-up setting  |
| Reset time setting<br>Inaccuracy: Reset time                                     | 0.000...150.000 s, step 0.005 s<br>$\pm 1.0\%$ or $\pm 25$ ms                                |

|                                       |        |
|---------------------------------------|--------|
| Instant reset time and start-up reset | <40 ms |
|---------------------------------------|--------|

### 8.2.1.18 Transformer status monitoring

Table. 8.2.1.18 - 462. Technical data for the transformer status monitoring function.

| Features                |  |
|-------------------------|--|
| Control scale           | Common transformer data settings for all functions in the transformer module, the protection logic, the HMI and the I/O.     |
| Settings                | Transformer application nominal data   |
| Other features          | Status hours counters (normal load, overload, high overload)<br>Transformer status signals<br>Transformer data for functions |
| Outputs                 |  |
| Light/no load           | $I_M < 0.2 \times I_N$   |
| Inrush HV side detected | $I_M < 0.2 \times I_N \rightarrow I_M > 1.3 \times I_N$  |
| Inrush LV side detected | $I_M < 0.2 \times I_N \rightarrow I_M > 1.3 \times I_N$  |
| Load normal             | $I_M > 0.2 \times I_N \dots I_M < 1.0 \times I_N$  |
| Overloading             | $I_M > 1.0 \times I_N \dots I_M < 1.3 \times I_N$  |
| High overload           | $I_M > 1.3 \times I_N$   |
| Inaccuracy              |  |
| Current detection       | $\pm 3\%$ of the set pick-up value $> 0.5 \times I_N$ setting. $5 \text{ mA} < 0.5 \times I_N$ setting                       |
| Detection time          | $\pm 0.5\%$ or $\pm 10 \text{ ms}$   |

### 8.2.1.19 Resistance temperature detectors (RTD)

Table. 8.2.1.19 - 463. Technical data of the resistance temperature detectors.

| Inputs   |   |
|--|---|
| Resistance input magnitudes                      | Measured temperatures measured by RTD sensors   |
| RTD channels                                     | 12 individual RTD channels  |
| Settable alarms                                  | 24 alarms available (two per each RTD channel)  |
| Pick-up  |   |
| Alarm setting range<br>Inaccuracy<br>Reset ratio | 101.00...2000.00 deg, setting step 0.1 deg (either $<$ or $>$ setting)<br>$\pm 3\%$ of the set pick-up value<br>97 % of the pick-up setting |

| Operation      |                   |
|----------------|-------------------|
| Operating time | Typically <500 ms |

### 8.2.1.20 Generator/motor/transformer differential protection ( $I_{db}$ / $I_{di}$ / $I_{0dHV}$ / $I_{0dLV}$ ; 87T/87G/87M/87N)

Table. 8.2.1.20 - 464. Technical data for the transformer differential protection function.

| Measurement inputs   |  |
|--|--|
| Current inputs (CT1 and CT2 current measurement module)              | Phase current inputs: $I_{L1}$ (A), $I_{L2}$ (B), $I_{L3}$ (C)<br>Residual current channel $I_{01}$ (Coarse)<br>Residual current channel $I_{02}$ (Fine)<br>Calculated residual current: $I_{L1}$ (A), $I_{L2}$ (B), $I_{L3}$ (C)  |
| Current input magnitudes   | The phase currents of the high-voltage and the low-voltage sides.<br>Residual current measurement for HV/LV REF protection.<br>Phase currents 2 <sup>nd</sup> and 5 <sup>th</sup> harmonic measurement.  |
| Characteristics (differential and REF)                               |  |
| Differential calculation mode<br>Bias calculation mode               | Add or subtract (CT direction)<br>Average or maximum (sensitivity)   |
| $I_{db}$ pick-up<br>Turnpoint 1<br>Slope 1<br>Turnpoint 2<br>Slope 2 | 0.01...100.00 %, step 0.01 %, default 10.00 %<br>0.01...50.00 $\times I_N$ , step 0.01 $\times I_N$ , default 1.00 $\times I_N$<br>0.01...250.00 %, step 0.01 %, default 10.00 %<br>0.01...50.00 $\times I_N$ , step 0.01 $\times I_N$ , default 3.00 $\times I_N$<br>0.01...250.00 % by step 0.01 %, default 200.00 % |
| $I_{di}$ pick-up   | 200.00...1500.00 %, step 0.01 %, default 600.00 %  |
| Internal harmonic blocking selection                                 | None, 2 <sup>nd</sup> harmonic, 5 <sup>th</sup> harmonic, both 2 <sup>nd</sup> and 5 <sup>th</sup> harmonic.   |
| 2 <sup>nd</sup> harmonic blocking pick-up                            | 0.01...50.00 %, step 0.01 %, default 15.00 %   |
| 5 <sup>th</sup> harmonic blocking pick-up                            | 0.01...50.00 %, step 0.01 %, default 35.00 %   |
| Inaccuracy:<br>- Differential current<br>- 2 <sup>nd</sup> harmonic  | $\pm 3.0 \% I_{SET}$ or $\pm 75$ mA (0.10...4.0 $\times I_{SET}$ )<br>$\pm 1.5 \% I_{SIDE1}$   |
| Instant operation time   |  |
| Instant operation time $> 1.05 \times I_{SET}$                       | <40 ms (Harmonic blocking active)  |
| Instant operation time $> 3.00 \times I_{SET}$                       | <30 ms (Harmonic blocking active)  |
| Instant operation time $> 3.00 \times I_{SET}$                       | ~15 ms (No harmonic blocking)  |
| Reset  |  |
| Reset ratio: differential current                                    | 97 % of the differential current setting (typically)   |

|            |        |
|------------|--------|
| Reset time | <50 ms |
|------------|--------|

**NOTICE!**

The harmonic current is set and calculated according to the highest amplitude of side 1, 2 or 3 currents ( $I_h\%/I_{SIDE1/2/3}$ ). The harmonic current is calculated individually for each phase.

### 8.2.1.21 Arc fault protection ( $I_{Arc}>/I_{0Arc}>$ ; $50Arc/50NArc$ ) (optional)

Table. 8.2.1.21 - 465. Technical data for the arc fault protection function.

| Measurement inputs   |  |
|--|--|
| Current inputs   | Phase current inputs: $I_{L1}$ (A), $I_{L2}$ (B), $I_{L3}$ (C)<br>Residual current channel $I_{01}$ (Coarse)<br>Residual current channel $I_{02}$ (Fine)                               |
| Current input magnitudes   | Sample-based phase current measurement<br>Sample-based residual current measurement  |
| Arc point sensor inputs  | Channels S1, S2, S3, S4 (pressure and light sensor, or light-only sensor)<br>Up to three (3) sensors per channel   |
| System frequency operating range   | 6.00...75.00 Hz  |
| Pick-up  |  |
| Pick-up current setting (phase current)<br>Pick-up current setting (residual current)<br>Pick-up light intensity | 0.05...40.00 $\times I_N$ , setting step 0.01 $\times I_N$<br>0.05...40.00 $\times I_N$ , setting step 0.01 $\times I_N$<br>8, 25 or 50 kLx (the sensor is selected in the order code) |
| Starting inaccuracy ( $I_{Arc}>$ and $I_{0Arc}>$ )   | $\pm 3\%$ of the set pick-up value $> 0.5 \times I_N$ setting. 5 mA $< 0.5 \times I_N$ setting.  |
| Point sensor detection radius  | 180 degrees  |
| Operation time   |  |
| Light only:<br>- Semiconductor outputs HSO1 and HSO2<br>- Regular relay outputs                                  | Typically 7 ms (3...12 ms)<br>Typically 10 ms (6.5...15 ms)  |
| Light + current criteria (zone 1...4):<br>- Semiconductor outputs HSO1 and HSO2<br>- Regular relay outputs       | Typically 10 ms (6.5...14 ms)<br>Typically 14 ms (10...18 ms)  |
| Arc BI only:<br>- Semiconductor outputs HSO1 and HSO2<br>- Regular relay outputs                                 | Typically 7 ms (2...12 ms)<br>Typically 10 ms (6.5...15 ms)  |

## 8.2.2 Control functions

### 8.2.2.1 Automatic voltage regulator (90)

Table. 8.2.2.1 - 466. Technical data for the automatic voltage regulator function.

| Measurement inputs  |  |
|---|--|
| Voltage inputs  | U <sub>L1</sub> , U <sub>L2</sub> , U <sub>L3</sub><br>U <sub>L12</sub> , U <sub>L23</sub> , U <sub>L31</sub> + U <sub>0</sub><br>U4 channel voltage   |
| Voltage input magnitudes  | RMS line-to-line voltages<br>U4 channel RMS voltage  |
| Current inputs  | Phase current inputs: I <sub>L1</sub> (A), I <sub>L2</sub> (B), I <sub>L3</sub> (C)  |
| Current input magnitudes (I> blocking)  | RMS phase currents   |
| Pick-up   |  |
| Pick-up area (U>/<, U>>/<<, U>>>/<<<)<br>Tap step effect (1...70 steps)<br>I> blocking          | 0.10...30.00 %U <sub>N</sub> , setting step 0.01 %U <sub>N</sub><br>0.01...10.00 %U <sub>N</sub> , setting step 0.01 %U <sub>N</sub><br>0.00...40.00 × I <sub>N</sub> , setting step 0.01 × I <sub>N</sub> |
| Inaccuracy:<br>- Voltage<br>- Current   | ±1.5 %U <sub>SET</sub><br>±0.5 %I <sub>SET</sub> or ±15 mA (0.10...4.0 × I <sub>SET</sub> )  |
| Operating time  |  |
| Control pulse min/max and time between<br>Definite time function operating time setting         | 0.00...1800.00 s, setting step 0.005 s<br>0.00...1800.00 s, setting step 0.005 s   |
| Inaccuracy:<br>- Definite time (U <sub>M</sub> /U <sub>SET</sub> ratio 1.05→)                   | ±1.5 % or ±50 ms   |
| Integrated operating time setting:<br>- Multiplier (k)  | 0.000...1800.000, setting step 0.005   |
| Inaccuracy:<br>- IDMT operating time<br>- IDMT minimum operating time                           | ±1.5 % or ±35 ms<br>±20 ms   |
| Instant operation time  |  |
| Start time and instant operation time (trip):<br>- U <sub>M</sub> /U <sub>SET</sub> ratio 1.05→ | <50 ms   |
| Reset   |  |
| Reset ratio:<br>- Voltage<br>- Current  | 95/105 % of the pick-up voltage setting<br>97 % of the pick-up current setting   |
| Instant reset time and start-up reset   | <50 ms   |

### 8.2.2.2 Setting group selection

Table. 8.2.2.2 - 467. Technical data for the setting group selection function.

| Settings and control modes |  |
|----------------------------|--|
| Setting groups             | 8 independent, control-prioritized setting groups                                  |
| Control scale              | Common for all installed functions which support setting groups                    |
| Control mode               |  |
| Local                      | Any binary signal available in the device  |
| Remote                     | Force change overrule of local controls either from the setting tool, HMI or SCADA |
| Operation time             |  |
| Reaction time              | <5 ms from receiving the control signal  |

### 8.2.2.3 Object control and monitoring

Table. 8.2.2.3 - 468. Technical data for the object control and monitoring function.

| General                                       |   |
|---|---|
| Number of objects                             | 10  |
| Supported object types                        | Circuit breaker<br>Circuit breaker with withdrawable cart<br>Disconnecter (MC)<br>Disconnecter (GND)<br>Custom object image |
| Signals                                       |   |
| Input signals                                 | Digital inputs<br>Software signals  |
| Output signals                                | Close command output<br>Open command output   |
| Operation time                                |   |
| Breaker traverse time setting                 | 0.02...500.00 s, setting step 0.02 s  |
| Max. close/open command pulse length          | 0.02...500.00 s, setting step 0.02 s  |
| Control termination time out setting          | 0.02...500.00 s, setting step 0.02 s  |
| Inaccuracy:<br>- Definite time operating time | ±0.5 % or ±10 ms  |
| Breaker control operation time                |   |
| External object control time                  | <75 ms  |
| Object control during auto-reclosing          | See the technical sheet for the auto-reclosing function.  |

Table. 8.2.2.3 - 469. Technical data for the circuit breaker wear monitoring function.

| Pick-up  |  |
|--|--|
| Breaker characteristics settings:<br>- Nominal breaking current<br>- Maximum breaking current<br>- Operations with nominal current<br>- Operations with maximum breaking current | 0.00...100.00 kA, setting step 0.001 kA<br>0.00...100.00 kA, setting step 0.001 kA<br>0...200 000 operations, setting step 1 operation<br>0...200 000 operations, setting step 1 operation |
| Pick-up setting for Alarm 1 and Alarm 2  | 0...200 000 operations, setting step 1 operation   |
| Inaccuracy   |  |
| Inaccuracy for current/operations counter:<br>- Current measurement element<br>- Operation counter   | $0.1 \times I_N > I < 2 \times I_N \pm 0.2\%$ of the measured current, rest 0.5 %<br>$\pm 0.5\%$ of operations deducted  |

## 8.2.2.4 Indicator object monitoring

Table. 8.2.2.4 - 470. Technical data for the indicator object monitoring function.

| General                |   |
|------------------------|---|
| Number of objects      | 10  |
| Supported object types | Disconnecter (GND)<br>Custom object image |
| Signals                |   |
| Input signals          | Digital inputs<br>Software signals        |

## 8.2.2.5 Cold load pick-up (CLPU)

Table. 8.2.2.5 - 471. Technical data for the cold load pick-up function.

| Measurement inputs                                       |  |
|--|--|
| Current inputs   | Phase current inputs: $I_{L1}$ (A), $I_{L2}$ (B), $I_{L3}$ (C)     |
| Current input magnitudes                                 | RMS phase currents   |
| Pick-up  |  |
| Pick-up current setting<br>- $I_{LOW}/I_{HIGH}/I_{OVER}$ | $0.01...40.00 \times I_N$ , setting step $0.01 \times I_N$         |
| Reset ratio  | 97 % of the pick-up current setting                                |
| Inaccuracy:<br>- Current                                 | $\pm 0.5\% I_{SET}$ or $\pm 15$ mA ( $0.10...4.0 \times I_{SET}$ ) |
| Operation time   |  |

|   |  |
|---|--|
| Definite time function operating time settings:<br>- tSET<br>- tMAX<br>- tMIN       | 0.000...1800.000 s, setting step 0.005 s<br>0.000...1800.000 s, setting step 0.005 s<br>0.000...1800.000 s, setting step 0.005 s |
| Inaccuracy:<br>- Definite time (I <sub>M</sub> /I <sub>SET</sub> ratio = 1.05/0.95) | ±1.0 % or ±45 ms   |
| <b>Instant operation time</b>   |  |
| CLPU activation and release   | <45 ms (measured from the trip contact)  |

**NOTICE!**

A single-phase current (IL1, IL2 or IL3) is enough to prolong or release the blocking during an overcurrent condition.

### 8.2.2.6 Switch-on-to-fault (SOTF)

Table. 8.2.2.6 - 472. Technical data for the switch-on-to-fault function.

|                                |  |
|--------------------------------|--|
| <b>Initialization signals</b>  |  |
| SOTF activate input            | Any blocking input signal (Object closed signal, etc.) |
| <b>Pick-up</b>                 |  |
| SOTF function input            | Any blocking input signal (> or similar)               |
| <b>SOTF activation time</b>    |  |
| Activation time                | <40 ms (measured from the trip contact)                |
| <b>SOTF release time</b>       |  |
| Release time setting           | 0.000...1800.000 s, setting step 0.005 s               |
| Inaccuracy:<br>- Definite time | ±1.0 % or ±30 ms                                       |
| SOTF instant release time      | <40 ms (measured from the trip contact)                |

### 8.2.2.7 Vector jump ( $\Delta\varphi$ ; 78)

Table. 8.2.2.7 - 473. Technical data for the vector jump protection function.

|                           |  |
|---------------------------|--|
| <b>Measurement inputs</b> |  |
| Voltage inputs            | U <sub>L1</sub> , U <sub>L2</sub> , U <sub>L3</sub><br>U <sub>L12</sub> , U <sub>L23</sub> , U <sub>L31</sub> + U <sub>0</sub>   |
| Monitored voltages        | Any or all system line-to-line voltage(s)<br>Any or all system line-to-neutral voltage(s)<br>Specifically chosen line-to-line or line-to-neutral voltage<br>U4 channel voltage |
| <b>Pick-up</b>            |  |

|  |  |
|--|--|
| Pick-up setting  | 0.05...30.00°, setting step 0.01°                                      |
| Inaccuracy:<br>- Voltage angle   | ±30% overreach or 1.00 °   |
| <b>Low-voltage blocking</b>  |  |
| Pick-up setting  | 0.01...100.00 %U <sub>N</sub> , setting step 0.01 %U <sub>N</sub>      |
| Inaccuracy:<br>- Voltage   | ±1.5 %U <sub>SET</sub> or ±30 mV                                       |
| <b>Instant operation time</b>  |  |
| Alarm and trip operation time:<br>- (Im/Iset ratio > ±30% overreach or 1.00 °) | <40 ms (typically 30 ms) 50/60 Hz<br><50 ms (typically 40 ms) 16.67 Hz |
| <b>Reset</b>   |  |
| Trip pulse   | ~5-10ms  |

### 8.2.2.8 Synchrocheck ( $\Delta V/\Delta a/\Delta f$ ; 25)

Table. 8.2.2.8 - 474. Technical data for the synchrocheck function.

|   |  |
|---|--|
| <b>Input signals</b>                                  |  |
| Voltage inputs  | U1, U2, U3 or U4 voltage channel   |
| Voltage input magnitudes                              | RMS line-to-line or line-to-neutral voltages<br>U3 or U4 voltage channel RMS                                 |
| <b>Pick-up</b>  |  |
| U diff < setting                                      | 2.00...50.00 %U <sub>N</sub> , setting step 0.01 %U <sub>N</sub>   |
| Angle diff < setting                                  | 3.0...90.0 deg, setting step 0.10 deg  |
| Freq diff < setting                                   | 0.05...0.50 Hz, setting step 0.01 Hz   |
| Inaccuracy:<br>- Voltage<br>- Frequency<br>- Angle    | ±3.0 %U <sub>SET</sub> or ±0.3 %U <sub>N</sub><br>±25 mHz (U > 30 V secondary)<br>±1.5° (U > 30 V secondary) |
| <b>Reset</b>  |  |
| Reset ratio:<br>- Voltage<br>- Frequency<br>- Angle   | 99 % of the pick-up voltage setting<br>20 mHz<br>±2.0°   |
| <b>Activation time</b>                                |  |
| Activation (to LD/DL/DD)<br>Activation (to Live Live) | <35 ms<br><60 ms   |
| Reset   | <40 ms   |

| Bypass modes                      |  |
|-----------------------------------|--|
| Voltage check mode (excluding LL) | LL+LD, LL+DL, LL+DD, LL+LD+DL, LL+LD+DD, LL+DL+DD, bypass  |
| U live > limit<br>U dead < limit  | 0.10...100.00 %U <sub>N</sub> , setting step 0.01 %U <sub>N</sub><br>0.00...100.00 %U <sub>N</sub> , setting step 0.01 %U <sub>N</sub> |

**NOTICE!**

The minimum voltage for direction and frequency solving is 20.0 %U<sub>N</sub>.

## 8.2.3 Monitoring functions

### 8.2.3.1 Current transformer supervision

Table. 8.2.3.1 - 475. Technical data for the current transformer supervision function.

| Measurement inputs   |  |
|--|--|
| Current inputs   | Phase current inputs: I <sub>L1</sub> (A), I <sub>L2</sub> (B), I <sub>L3</sub> (C)<br>Residual current channel I <sub>01</sub> (Coarse) (optional)<br>Residual current channel I <sub>02</sub> (Fine) (optional)  |
| Current input magnitudes   | RMS phase currents<br>RMS residual current (I <sub>01</sub> , I <sub>02</sub> ) (optional)   |
| Pick-up  |  |
| Pick-up current settings:<br>- I <sub>SET</sub> high limit<br>- I <sub>SET</sub> low limit<br>- I <sub>SUM</sub> difference<br>- I <sub>SET</sub> ratio<br>- I <sub>2</sub> /I <sub>1</sub> ratio    | 0.10...40.00 × I <sub>N</sub> , setting step 0.01 × I <sub>N</sub><br>0.10...40.00 × I <sub>N</sub> , setting step 0.01 × I <sub>N</sub><br>0.10...40.00 × I <sub>N</sub> , setting step 0.01 × I <sub>N</sub><br>0.01...100.00 %, setting step 0.01 %<br>0.01...100.00 %, setting step 0.01 %             |
| Inaccuracy:<br>- Starting I <sub>L1</sub> , I <sub>L2</sub> , I <sub>L3</sub><br>- Starting I <sub>2</sub> /I <sub>1</sub><br>- Starting I <sub>01</sub> (1 A)<br>- Starting I <sub>02</sub> (0.2 A) | ±0.5 %I <sub>SET</sub> or ±15 mA (0.10...4.0 × I <sub>SET</sub> )<br>±1.0 %I <sub>2SET</sub> / I <sub>1SET</sub> or ±100 mA (0.10...4.0 × I <sub>N</sub> )<br>±0.5 %I <sub>0SET</sub> or ±3 mA (0.005...10.0 × I <sub>SET</sub> )<br>±1.5 %I <sub>0SET</sub> or ±1.0 mA (0.005...25.0 × I <sub>SET</sub> ) |
| Time delay for alarm   |  |
| Definite time function operating time setting  | 0.000...1800.000 s, setting step 0.005 s   |
| Inaccuracy_<br>- Definite time (I <sub>M</sub> /I <sub>SET</sub> ratio > 1.05)   | ±2.0 % or ±80 ms   |
| Instant operation time (alarm):<br>- I <sub>M</sub> /I <sub>SET</sub> ratio > 1.05   | <80 ms   |
| Reset  |  |
| Reset ratio  | 97/103 % of the pick-up current setting  |
| Instant reset time and start-up reset  | <80 ms   |

### 8.2.3.2 Voltage transformer supervision (60)

Table. 8.2.3.2 - 476. Technical data for the voltage transformer supervision function.

| Measurement inputs  |   |
|---|---|
| Voltage inputs  | U <sub>L1</sub> , U <sub>L2</sub> , U <sub>L3</sub><br>U <sub>L12</sub> , U <sub>L23</sub> , U <sub>L31</sub>   |
| Voltage input magnitudes  | RMS line-to-line or line-to-neutral voltages  |
| Pick-up   |   |
| Pick-up settings:<br>- Voltage (low pick-up)<br>- Voltage (high pick-up)<br>- Angle shift limit | 0.05...0.50 × U <sub>N</sub> , setting step 0.01 × U <sub>N</sub><br>0.50...1.10 × U <sub>N</sub> , setting step 0.01 × U <sub>N</sub><br>2.00...90.00 deg, setting step 0.10 deg |
| Inaccuracy:<br>- Voltage<br>- U angle (U > 1 V)   | ±1.5 %U <sub>SET</sub><br>±1.5°   |
| External line/bus side pick-up (optional)   | 0 → 1   |
| Time delay for alarm  |   |
| Definite time function operating time setting   | 0.000...1800.000 s, setting step 0.005 s  |
| Inaccuracy:<br>- Definite time (U <sub>M</sub> /U <sub>SET</sub> ratio > 1.05/0.95)             | ±1.0 % or ±35 ms  |
| Instant operation time (alarm):<br>- U <sub>M</sub> /U <sub>SET</sub> ratio > 1.05/0.95         | <80 ms  |
| VTS MCB trip bus/line (external input)  | <50 ms  |
| Reset   |   |
| Reset ratio   | 97/103 % of the pick-up voltage setting   |
| Reset time setting<br>Inaccuracy: Reset time  | 0.000...150.000 s, step 0.005 s<br>±2.0 % or ±80 ms   |
| Instant reset time and start-up reset   | <50 ms  |
| VTS MCB trip bus/line (external input)  | <50 ms  |



**NOTICE!**

When turning on the auxiliary power of a device, the normal condition of a stage has to be fulfilled before tripping.

### 8.2.3.3 Circuit breaker wear monitoring

Table. 8.2.3.3 - 477. Technical data for the circuit breaker wear monitoring function.

| Pick-up |  |
|---------|--|
|---------|--|

|  |  |
|--|--|
| Breaker characteristics settings:<br>- Nominal breaking current<br>- Maximum breaking current<br>- Operations with nominal current<br>- Operations with maximum breaking current | 0.00...100.00 kA, setting step 0.001 kA<br>0.00...100.00 kA, setting step 0.001 kA<br>0...200 000 operations, setting step 1 operation<br>0...200 000 operations, setting step 1 operation |
| Pick-up setting for Alarm 1 and Alarm 2  | 0...200 000 operations, setting step 1 operation   |
| <b>Inaccuracy</b>  |  |
| Inaccuracy for current/operations counter:<br>- Current measurement element<br>- Operation counter   | $0.1 \times I_N > I < 2 \times I_N \pm 0.2\%$ of the measured current, rest 0.5 %<br>$\pm 0.5\%$ of operations deducted  |

### 8.2.3.4 Current total harmonic distortion

Table. 8.2.3.4 - 478. Technical data for the total harmonic distortion function.

|  |  |
|--|--|
| <b>Input signals</b>   |  |
| Current inputs   | Phase current inputs: $I_{L1}$ (A), $I_{L2}$ (B), $I_{L3}$ (C)<br>Residual current channel $I_{01}$ (Coarse)<br>Residual current channel $I_{02}$ (Fine) |
| Current input magnitudes   | Current measurement channels (FFT result) up to the 31 <sup>st</sup> harmonic component.   |
| <b>Pick-up</b>   |  |
| Operating modes  | Power THD<br>Amplitude THD   |
| Pick-up setting for all comparators  | 0.10...200.00 % , setting step 0.01 %  |
| Inaccuracy   | $\pm 3\%$ of the set pick-up value $> 0.5 \times I_N$ setting; $5 \text{ mA} < 0.5 \times I_N$ setting.  |
| <b>Time delay</b>  |  |
| Definite time function operating time setting for all timers   | 0.000...1800.000 s, setting step 0.005 s   |
| Inaccuracy:<br>- Definite time operating time<br>- Instant operating time, when $I_M/I_{SET}$ ratio $> 3$<br>- Instant operating time, when $I_M/I_{SET}$ ratio $1.05 < I_M/I_{SET} < 3$ | $\pm 0.5\%$ or $\pm 10 \text{ ms}$<br>Typically $< 20 \text{ ms}$<br>Typically $< 25 \text{ ms}$   |
| <b>Reset</b>   |  |
| Reset time   | Typically $< 10 \text{ ms}$  |
| Reset ratio  | 97 %   |

### 8.2.3.5 Fault locator (21FL)

Table. 8.2.3.5 - 479. Technical data for the fault locator function.

| Input signals   |   |
|---|---|
| Current inputs  | Phase current inputs: $I_{L1}$ (A), $I_{L2}$ (B), $I_{L3}$ (C)                  |
| Voltage inputs  | $U_{L1}$ , $U_{L2}$ , $U_{L3}$<br>$U_{L12}$ , $U_{L23}$ , $U_{L31} + U_0$       |
| Calculated reactance magnitudes when line-to-neutral voltages available | $X_{L12}$ , $X_{L23}$ , $X_{L31}$ , $X_{L1}$ , $X_{L2}$ , $X_{L3}$              |
| Calculated reactance magnitudes when line-to-line voltages available    | $X_{L12}$ , $X_{L23}$ , $X_{L31}$   |
| Pick-up   |   |
| Trigger current >   | $0.00 \dots 40.00 \times I_N$ , setting step $0.01 \times I_N$                  |
| Inaccuracy:<br>- Triggering   | $\pm 0.5 \% I_{SET}$ or $\pm 15 \text{ mA}$ ( $0.10 \dots 4.0 \times I_{SET}$ ) |
| Reactance   |   |
| Reactance per kilometer   | $0.000 \dots 5.000 \text{ s}$ , setting step $0.001 \text{ } \Omega/\text{km}$  |
| Inaccuracy:<br>- Reactance  | $\pm 5.0 \%$ (typically)  |
| Operation (Triggering)  |   |
| Activation  | From the trip signal of any protection stage                                    |
| Minimum operation time  | At least $0.040 \text{ s}$ of stage operation time required                     |

### 8.2.3.6 Event logger

Table. 8.2.3.6 - 480. Technical data for the event logger function.

| General information        |               |
|----------------------------|---------------|
| Event history capacity     | 15 000 events |
| Event timestamp resolution | 1 ms          |

### 8.2.3.7 Disturbance recorder

Table. 8.2.3.7 - 481. Technical data for the disturbance recorder function.

| Recorded values          |  |
|--------------------------|--|
| Recorder analog channels | $0 \dots 20$ channels<br>Freely selectable |

|                           |  |
|---------------------------|--|
| Recorder digital channels | 0...96 channels<br>Freely selectable analog and binary signals<br>1 ms or 5 ms sample rate (FFT)   |
| <b>Performance</b>        |  |
| Sample rate               | 8, 16, 32 or 64 samples/cycle  |
| Recording length          | 0.000...1800.000 s, setting step 0.001 s<br>The maximum length is determined by the chosen signals.  |
| Number of recordings      | 0...100, 60 MB of shared flash memory reserved<br>The maximum number of recordings according to the chosen signals and operation time setting combined |

## 8.3 Tests and environmental

### Electrical environment compatibility

Table. 8.3 - 482. Disturbance tests.

|  |   |
|--|---|
| <b>All tests</b>   | CE-approved and tested according to EN 60255-26   |
| <b>Emissions</b>   |   |
| Conducted emissions:<br>EN 60255-26 Ch. 5.2, CISPR 22            | 150 kHz...30 MHz  |
| Radiated emissions:<br>EN 60255-26 Ch. 5.1, CISPR 11             | 30...1 000 MHz  |
| <b>Immunity</b>  |   |
| Electrostatic discharge (ESD):<br>EN 60255-26, IEC 61000-4-2     | Air discharge 15 kV<br>Contact discharge 8 kV   |
| Electrical fast transients (EFT):<br>EN 60255-26, IEC 61000-4-4  | Power supply input 4 kV, 5/50 ns, 5 kHz<br>Other inputs and outputs 4 kV, 5/50 ns, 5 kHz<br><b>NOTE:</b> Shielded cable required for ethernet communication |
| Surge:<br>EN 60255-26, IEC 61000-4-5                             | Between wires: 2 kV, 1.2/50 $\mu$ s<br>Between wire and earth: 4 kV, 1.2/50 $\mu$ s   |
| Radiated RF electromagnetic field:<br>EN 60255-26, IEC 61000-4-3 | f = 80...1 000 MHz, 10 V/m  |
| Conducted RF field:<br>EN 60255-26, IEC 61000-4-6                | f = 150 kHz...80 MHz, 10 V (RMS)  |

Table. 8.3 - 483. Voltage tests.

|                                      |                    |
|--------------------------------------|--------------------|
| <b>Dielectric voltage test</b>       |                    |
| EN 60255-27, IEC 60255-5, EN 60255-1 | 2 kV, 50 Hz, 1 min |
| <b>Impulse voltage test</b>          |                    |

|                          |                             |
|--------------------------|-----------------------------|
| EN 60255-27, IEC 60255-5 | 5 kV, 1.2/50 $\mu$ s, 0.5 J |
|--------------------------|-----------------------------|

## Physical environment compatibility

Table. 8.3 - 484. Mechanical tests.

| Vibration test                          |   |
|---|---|
| EN 60255-1, EN 60255-27, IEC 60255-21-1 | 2...13.2 Hz, $\pm$ 3.5 mm<br>13.2...100 Hz, $\pm$ 1.0 g |
| Shock and bump test                     |   |
| EN 60255-1, EN 60255-27, IEC 60255-21-2 | 20 g, 1 000 bumps/dir.                                  |

Table. 8.3 - 485. Environmental tests.

| Damp heat (cyclic)         |  |
|----------------------------|--|
| EN 60255-1, IEC 60068-2-30 | Operational: +25...+55 °C, 93...97 % (RH), 12+12h  |
| Dry heat                   |  |
| EN 60255-1, IEC 60068-2-2  | Storage: +70 °C, 16 h<br>Operational: +55 °C, 16 h |
| Cold test                  |  |
| EN 60255-1, IEC 60068-2-1  | Storage: -40 °C, 16 h<br>Operational: -20 °C, 16 h |

Table. 8.3 - 486. Environmental conditions.

| IP classes                              |                             |
|---|-----------------------------|
| Casing protection class                 | IP54 (front)<br>IP21 (rear) |
| Temperature ranges                      |                             |
| Ambient service temperature range       | -35...+70 °C                |
| Transport and storage temperature range | -40...+70 °C                |
| Other                                   |                             |
| Altitude                                | <2000 m                     |
| Overvoltage category                    | III                         |
| Pollution degree                        | 2                           |

## Casing and package

Table. 8.3 - 487. Dimensions and weight.

| Without packaging (net) |  |
|-------------------------|--|
| Dimensions              | Height: 208 mm<br>Width: 257 mm (½ rack)<br>Depth: 165 mm (no cards or connectors) |
| Weight                  | Appr. 3.4 kg   |
| With packaging (gross)  |  |
| Dimensions              | Height: 250 mm<br>Width: 343 mm<br>Depth: 256 mm                                   |
| Weight                  | Appr. 4 kg   |

## 9 Ordering information

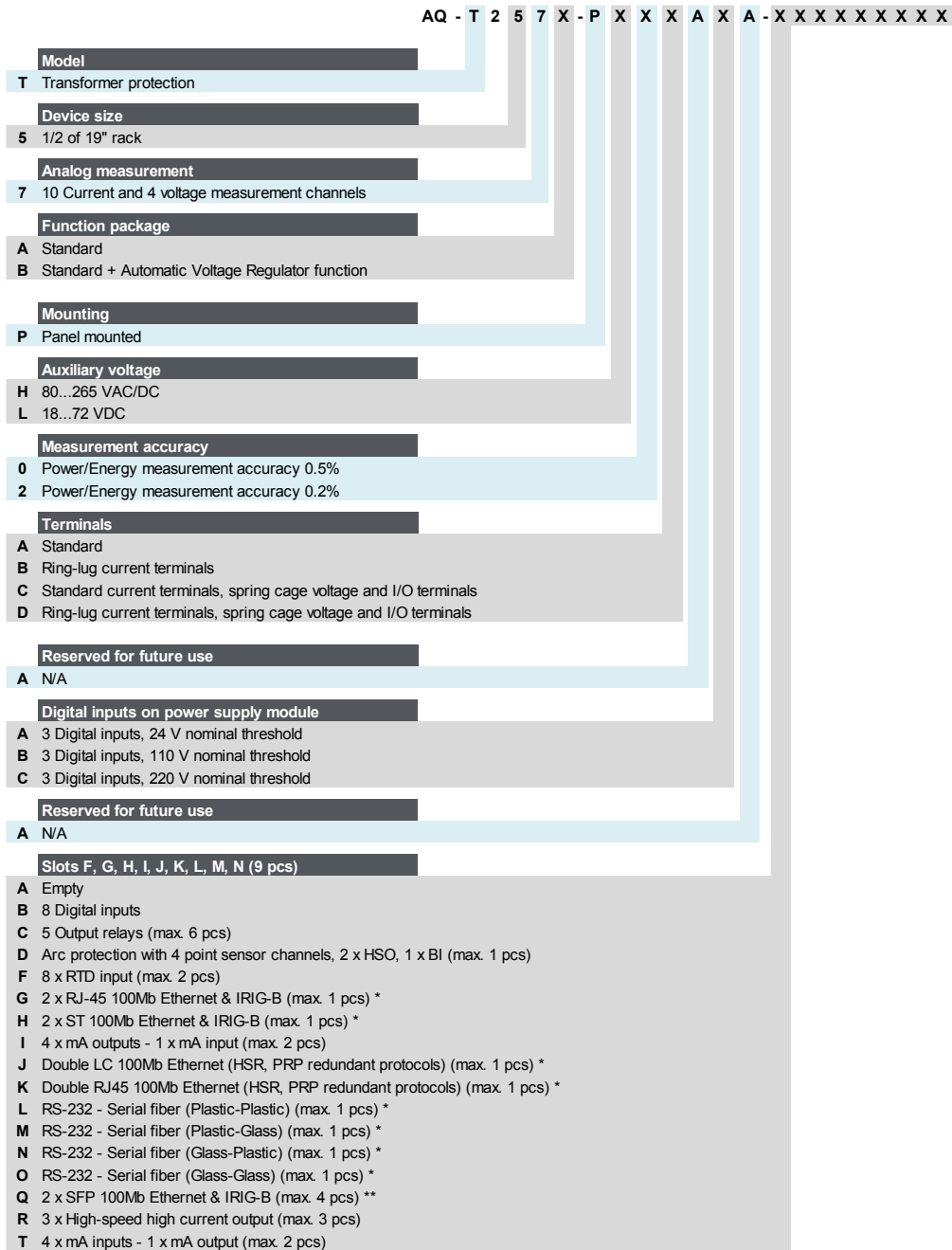

\* Can only be applied to the two last slots.  
\*\* Can only be applied to the four last slots. Requires an SFP adapter. See "Accessories" list.

### Accessories

| Order code | Description  | Note                                |
|------------|--|-------------------------------------|
| AX007      | External 6-channel 2 or 3 wires RTD Input module, pre-configured | Requires an external 24 VDC supply. |
| AX008      | External 8-ch Thermocouple mA Input module, pre-configured       | Requires an external 24 VDC supply. |

|        |   |                                    |
|--------|---|------------------------------------|
| AX020  | SFP module LC 2 km multi-mode                               | 2 km multi-mode fiber (1310 nm)    |
| AX021  | SFP module LC 40 km single-mode                             | 40 km single-mode fiber (1310 nm)  |
| AX022  | SFP module LC 120 km single-mode                            | 120 km single-mode fiber (1550 nm) |
| AX013  | AQ 250 series raising frame 120mm                           | -                                  |
| AQX014 | AQ 250 series raising frame 40mm                            | -                                  |
| AQX015 | AQ 250 series wall mounting bracket                         | -                                  |
| AQ-01A | Light point sensor unit (8,000 lux threshold)               | Max. cable length 200 m            |
| AQ-01B | Light point sensor unit (25,000 lux threshold)              | Max. cable length 200 m            |
| AQ-01C | Light point sensor unit (50,000 lux threshold)              | Max. cable length 200 m            |
| AQ-02A | Pressure and light point sensor unit (8,000 lux threshold)  | Max. cable length 200 m            |
| AQ-02B | Pressure and light point sensor unit (25,000 lux threshold) | Max. cable length 200 m            |
| AQ-02C | Pressure and light point sensor unit (50,000 lux threshold) | Max. cable length 200 m            |

## 10 Contact and reference information

### Manufacturer

Arcteq Relays Ltd.

### Visiting and postal address

Kvartsikatu 2 A 1  
65300 Vaasa, Finland

### Contacts

|                    |   |
|--------------------|---|
| Phone:             | +358 10 3221 370  |
| Website:           | <a href="http://arcteq.com">arcteq.com</a>  |
| Technical support: | <a href="http://arcteq.com/support-login">arcteq.com/support-login</a><br>+358 10 3221 388 (EET 9:00 – 17.00) |
| E-mail (sales):    | <a href="mailto:sales@arcteq.com">sales@arcteq.com</a>  |