

# AQ-1000

Arc quenching device

Instruction manual



## Table of contents

1 Document information .....	3
1.1 Revision history.....	3
1.2 Safety information.....	4
1.3 Safety precautions.....	5
2 Introduction.....	6
3 Installation.....	7
3.1 Device dimensions.....	7
3.2 Mechanical installation.....	12
3.3 Wiring.....	15
3.4 Device earthing .....	15
4 Device states .....	16
5 LED indicators.....	18
6 Binary input functions.....	20
7 Relay functions.....	21
8 SET button.....	22
9 Self-supervision functions: alarms and errors.....	23
10 Accessories and arc protection system devices.....	25
11 Arc protection system testing .....	26
11.1 Preparing AQ-1000 for commissioning tests.....	26
11.2 Testing individual arc sensors.....	27
11.3 Testing the full arc protection system.....	27
11.4 Testing with arc sensor tester.....	30
11.5 Restoring the quenching contacts.....	31
12 Application example.....	33
13 Technical data .....	35
13.1 Mounting and installation .....	35
13.2 Device ratings.....	35
13.3 Auxiliary voltage.....	36
13.4 Output relays .....	37
13.5 Binary inputs.....	37
13.6 Voltage tests.....	38
13.7 Environmental ratings .....	38
14 Ordering information .....	39
15 Contact and reference information.....	40

## Disclaimer

Please read these instructions carefully before using the equipment or taking any other actions with respect to the equipment. Only trained and qualified persons are allowed to perform installation, operation, service or maintenance of the equipment. Such qualified persons have the responsibility to take all appropriate measures, including e.g. use of authentication, encryption, anti-virus programs, safe switching programs etc. necessary to ensure a safe and secure environment and usability of the equipment. The warranty granted to the equipment remains in force only provided that the instructions contained in this document have been strictly complied with.

Nothing contained in this document shall increase the liability or extend the warranty obligations of the manufacturer Arcteq Relays Ltd. The manufacturer expressly disclaims any and all liability for any damages and/or losses caused due to a failure to comply with the instructions contained herein or caused by persons who do not fulfil the aforementioned requirements. Furthermore, the manufacturer shall not be liable for possible errors in this document.

Please note that you must always comply with applicable local legislation and regulations. The manufacturer gives no warranties that the content of this document is in all respects in line with local laws and regulations and assumes no liability for such possible deviations.

You are advised to notify the manufacturer in case you become aware of any errors in this document or of defects in the equipment.

The manufacturer reserves the right to update or amend this document at any time.

## Copyright

Copyright © Arcteq Relays Ltd. 2026. All rights reserved.

# 1 Document information

## 1.1 Revision history

Table. 1.1 - 1. Revision history for the AQ-1000 instruction manual.

<b>Revision</b>	<b>1.00</b>
Date	20 June 2016
Changes	<ul style="list-style-type: none"> <li>The first revision of the AQ-1000 instruction manual published.</li> </ul>
<b>Revision</b>	<b>1.01</b>
Date	22 June 2016
Changes	<ul style="list-style-type: none"> <li>Table of contents corrected.</li> </ul>
<b>Revision</b>	<b>1.02</b>
Date	3 April 2017
Changes	<ul style="list-style-type: none"> <li>Technical data updated.</li> </ul>
<b>Revision</b>	<b>1.03</b>
Date	10 October 2018
Changes	<ul style="list-style-type: none"> <li>Technical data updated.</li> <li>Connections updated.</li> <li>Layout updated.</li> </ul>
<b>Revision</b>	<b>1.04</b>
Date	12 November 2019
Changes	<ul style="list-style-type: none"> <li>Technical data updated.</li> <li>Self-supervision function updated.</li> <li>UL requirements added.</li> </ul>
<b>Revision</b>	<b>1.05</b>
Date	7 January 2020
Changes	<ul style="list-style-type: none"> <li>Technical data updated.</li> </ul>
<b>Revision</b>	<b>1.06</b>
Date	10 March 2022
Changes	<ul style="list-style-type: none"> <li>Operating time updated in the <a href="#">Introduction</a> chapter.</li> <li>Removed AQ-01 GIS sensor and AST-01 tester from the <a href="#">Accessories and arc protection system devices</a> chapter.</li> <li>Updated the link in the <a href="#">Application example</a> chapter.</li> </ul>
<b>Revision</b>	<b>1.07</b>

Date	5 January 2026
Changes	<ul style="list-style-type: none"> <li>Updated the Arcteq logo on the cover page.</li> </ul>
<b>Revision</b>	<b>1.08</b>
Date	24 April 2026
Changes	<ul style="list-style-type: none"> <li>Updated internal references with links.</li> <li>Removed all references to AST-01 (not in use) and to the AQtivate 1000 software (only used by Arcteq personnel).</li> <li>Added a warning about the forceful use of the button to the <a href="#">SET button</a> chapter.</li> <li>Added a warning about alarm connections to the <a href="#">Self-supervision functions: alarms and errors</a> chapter.</li> <li>Updated the images in the <a href="#">Device dimensions</a> chapter.</li> <li>Corrected a mistyped auxiliary voltage minimum in the <a href="#">Technical data</a> chapter.</li> </ul>
<b>Revision</b>	<b>1.09</b>
Date	16 June 2026
Changes	<ul style="list-style-type: none"> <li>Added the <a href="#">Safety information</a> chapter.</li> <li>Added AQ-103 and AQ-103 to the <a href="#">Accessories and arc protection system devices</a> chapter.</li> <li>Updated the images for the <a href="#">Testing the full arc protection system</a> chapter.</li> <li>Updated the image in the <a href="#">Application example</a> chapter.</li> <li>Updated the technical data of the connector type descriptions in the <a href="#">Mounting and installation</a> chapter.</li> <li>Added the length option of 20 meters for the connection fiber in the <a href="#">Ordering information</a> chapter.</li> </ul>

## 1.2 Safety information

This document contains important instructions that should be saved for future use. Read the document carefully before installing, operating, servicing, or maintaining this equipment. Please read and follow all the instructions carefully to prevent accidents, injury and damage to property.

Additionally, this document may contain four (4) types of special messages to call the reader's attention to useful information as follows:



### NOTICE!

"Notice" messages indicate relevant factors and conditions to the concept discussed in the text, as well as to other relevant advice.



### CAUTION!

"Caution" messages indicate a potentially hazardous situation which, if not avoided, could result in minor or moderate personal injury, in equipment/property damage, or software corruption.



### WARNING!

"Warning" messages indicate a potentially hazardous situation which, if not avoided, could result in death or serious personal injury as well as serious damage to equipment/property.



**DANGER!**

"Danger" messages indicate an imminently hazardous situation which, if not avoided, **will** result in death or serious personal injury.

These symbols are added throughout the document to ensure all users' personal safety and to avoid unintentional damage to the equipment or connected devices.

Please note that although these warnings relate to direct damage to personnel and/or equipment, it should be understood that operating damaged equipment may also lead to further, indirect damage to personnel and/or equipment. Therefore, we expect any user to fully comply with these special messages.

## 1.3 Safety precautions



**WARNING!**

Read these instructions carefully and inspect the equipment to become familiar with it before trying to install, operate, service, or maintain it. Any electrical equipment should be installed, operated, serviced, and maintained only by qualified personnel. Local safety regulations should be followed. Arcteq does not assume any responsibility for any consequences that may arise from the use of this material. We reserve the right to make changes to this document without prior notice.



**WARNING!**

The AQ-1000 arc quenching device is intended for making a low-impedance short-circuit between all the phases, which is comparable to a bolted short-circuit.

Installation shall not be done before the entire system has been verified to withstand a bolted short-circuit. This verification shall include (but is not limited to) the following:

- source transformers and generators,
- power, current, and voltage transformers,
- circuit breakers,
- busbars and cables,
- busbar insulators and supports,
- switchgear structure.



**WARNING!**

Before installation, it shall be verified that there is no intentional live feed or any unintentional back feed to the busbars.



**WARNING!**

During tripping, the equipment can exceed a noise level of 85 A-weighted decibels. It is recommended to wear proper hearing protection when making commissioning tests or when operating the device.



**WARNING!**

The device should not be removed nor any other service works done, when the energy storage component is charged or is being charged.

## 2 Introduction

AQ-1000 is a resettable arc quenching device. The device is used to mitigate the arc flash energy from an arc flash event. When an arc fault occurs, AQ-1000 creates a low-impedance, three-phase short circuit which extinguishes the arc and gives the circuit breaker time to open and completely clear the fault. The arc quenching time is less than 2 ms; when used together with Arcteq's arc protection system, the total arcing time can be reduced to below 4 ms.

The device can be tested up to one hundred (100) times under no-load conditions. This allows for complete testing and commissioning of the AQ-1000 device and the entire arc protection system to take place on-site. AQ-1000 can be used in low-voltage switchgears up to 690 V, with short-circuit currents up to 100 kA. Both new and retrofit installations are possible, which makes AQ-1000 an excellent choice for arc protection.

## 3 Installation



### NOTICE!

For the technical details related to installation and mounting, please refer to the [Technical data](#) chapter.

### 3.1 Device dimensions

Figure. 3.1 - 1. Device dimensions from the front.

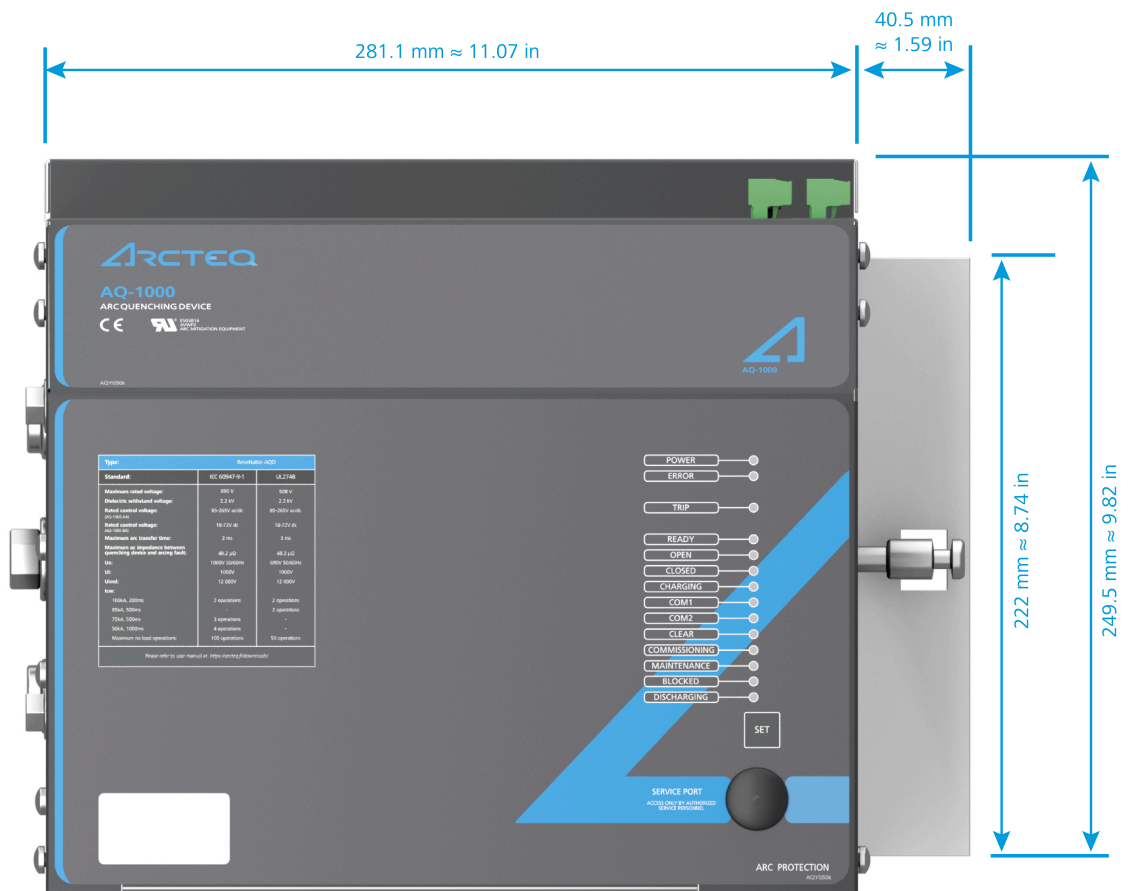

Figure. 3.1 - 2. Device dimensions from the left side.

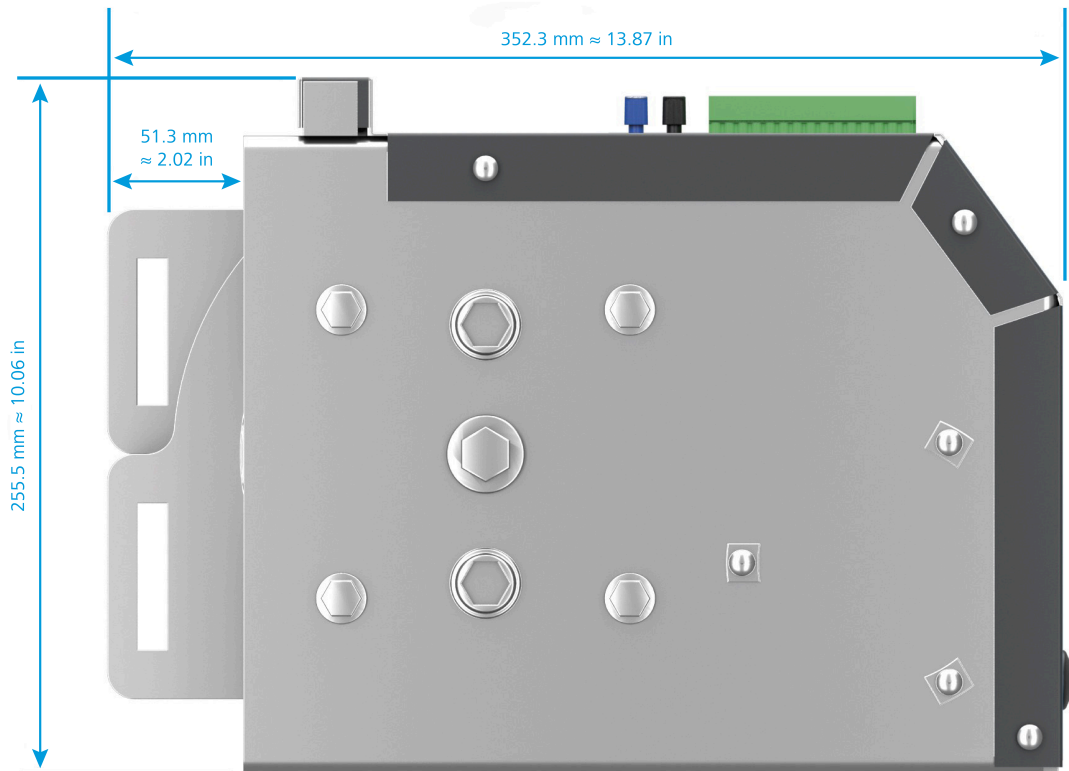

Figure. 3.1 - 3. Reset handle movement area and space reservation.

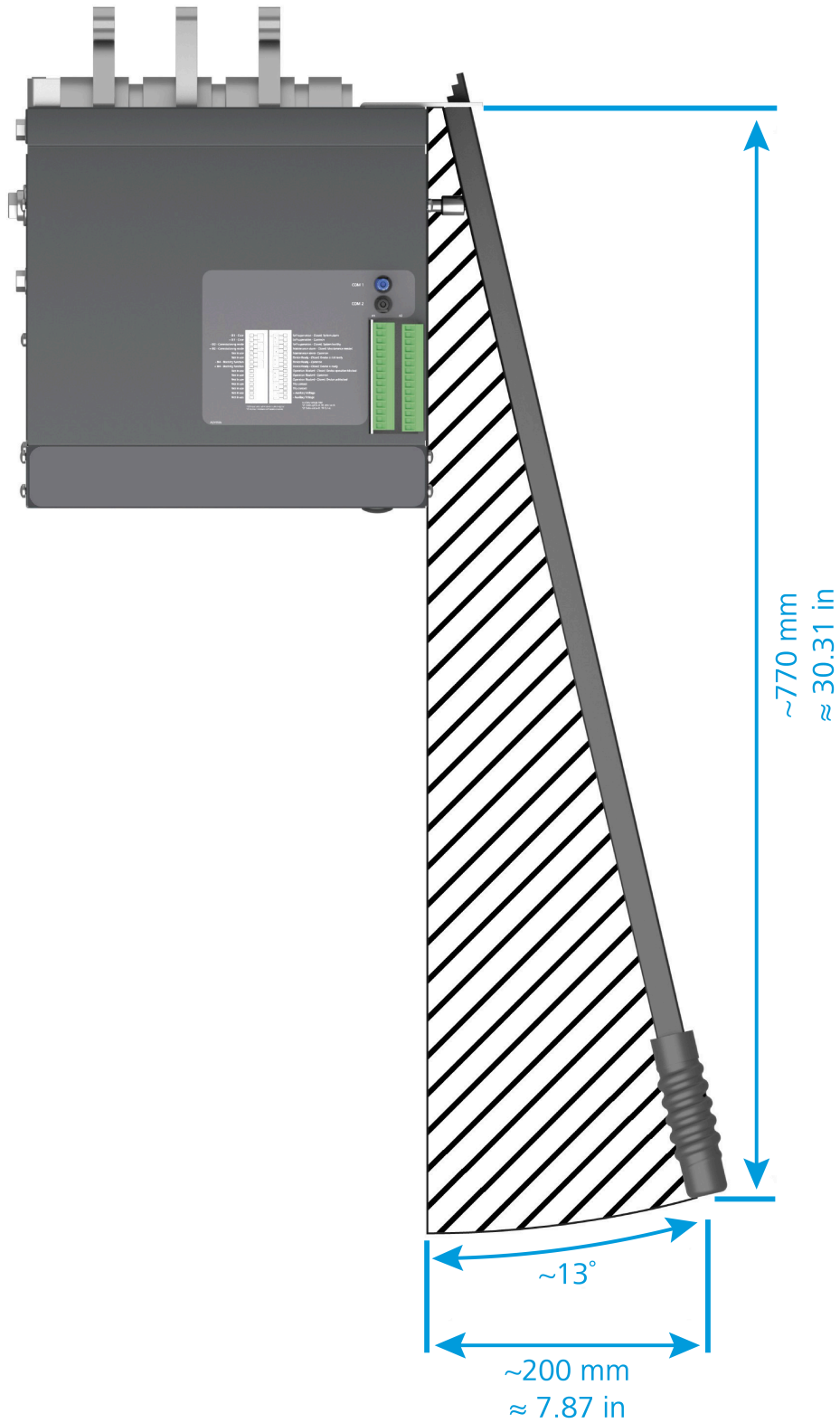

Figure. 3.1 - 4. Mounting dimensions from the bottom.

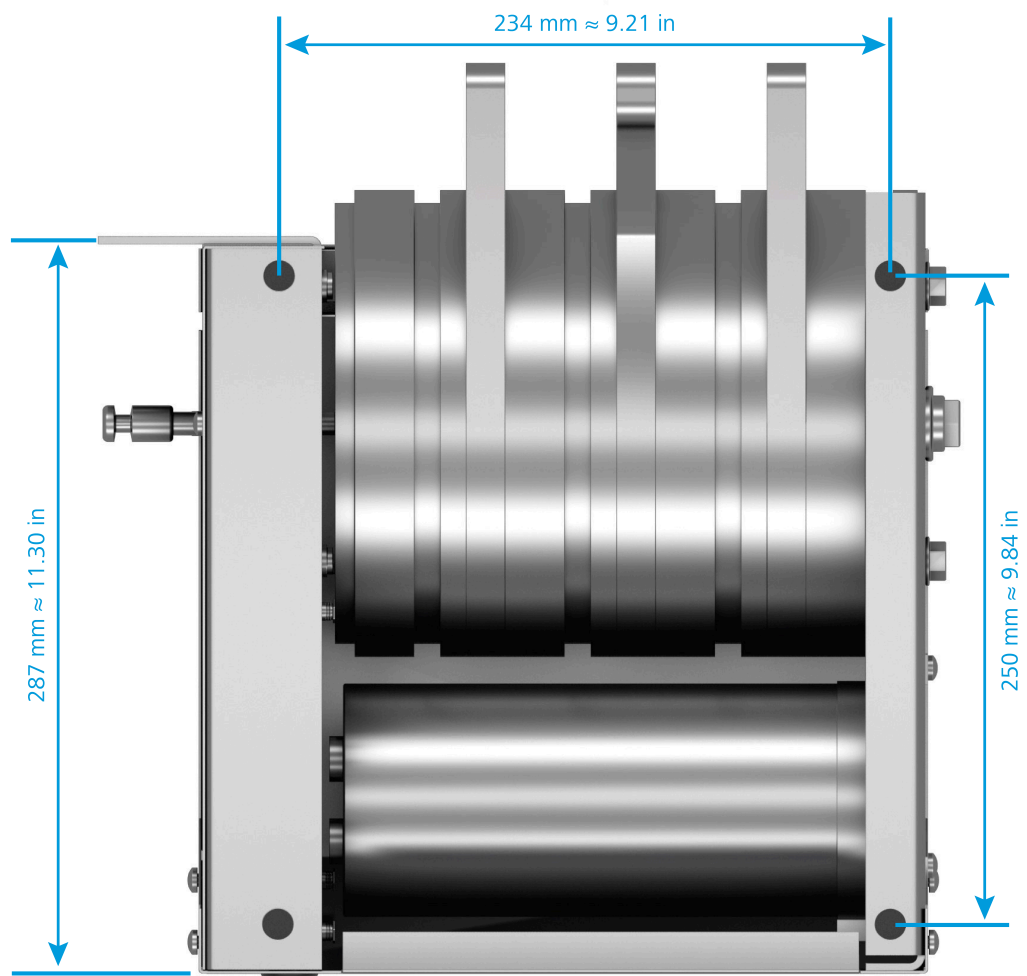
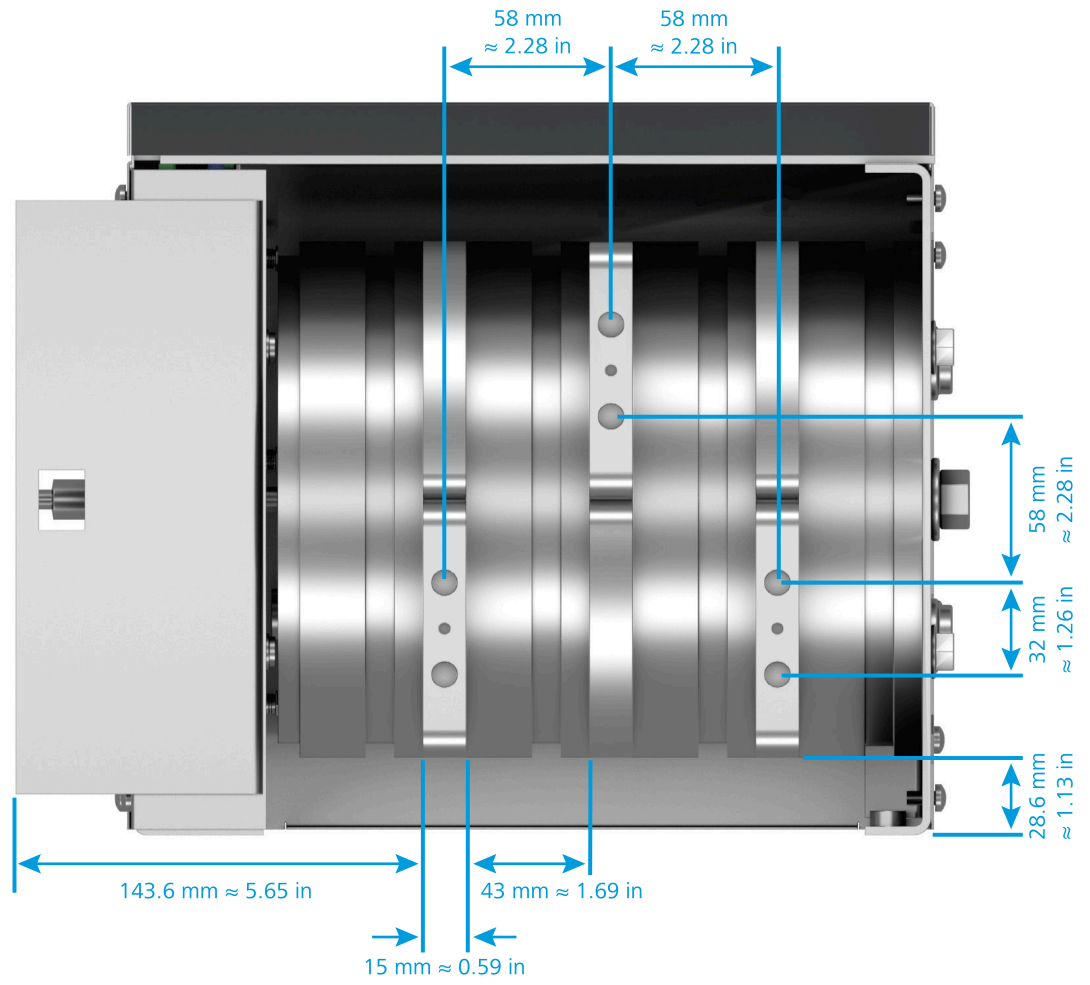

Figure. 3.1 - 5. Busbar joint dimensions form the back.



## 3.2 Mechanical installation

Figure. 3.2 - 6. Installation picture – tray assembly.

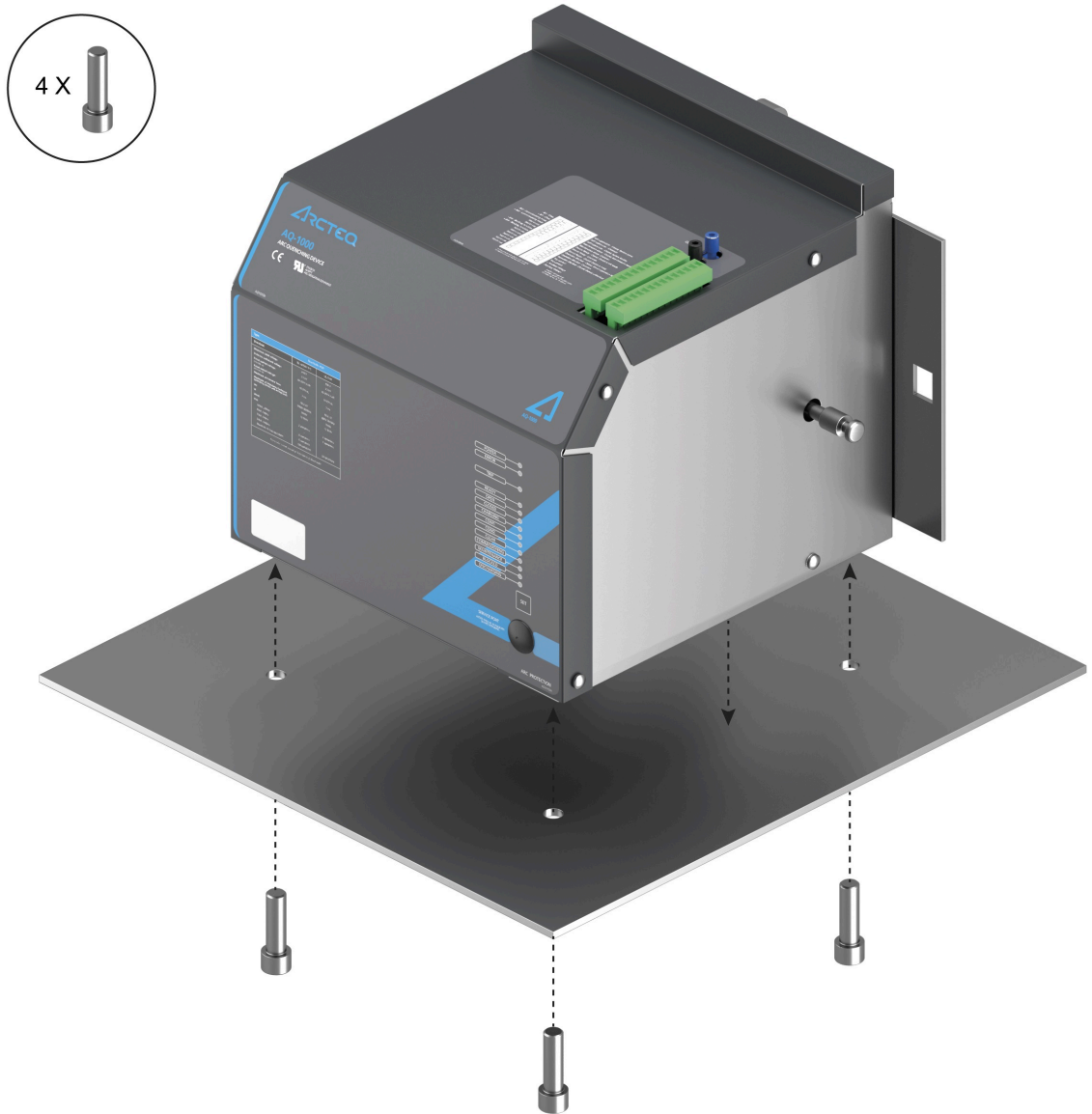

Figure. 3.2 - 7. Installation picture – C-rail assembly.

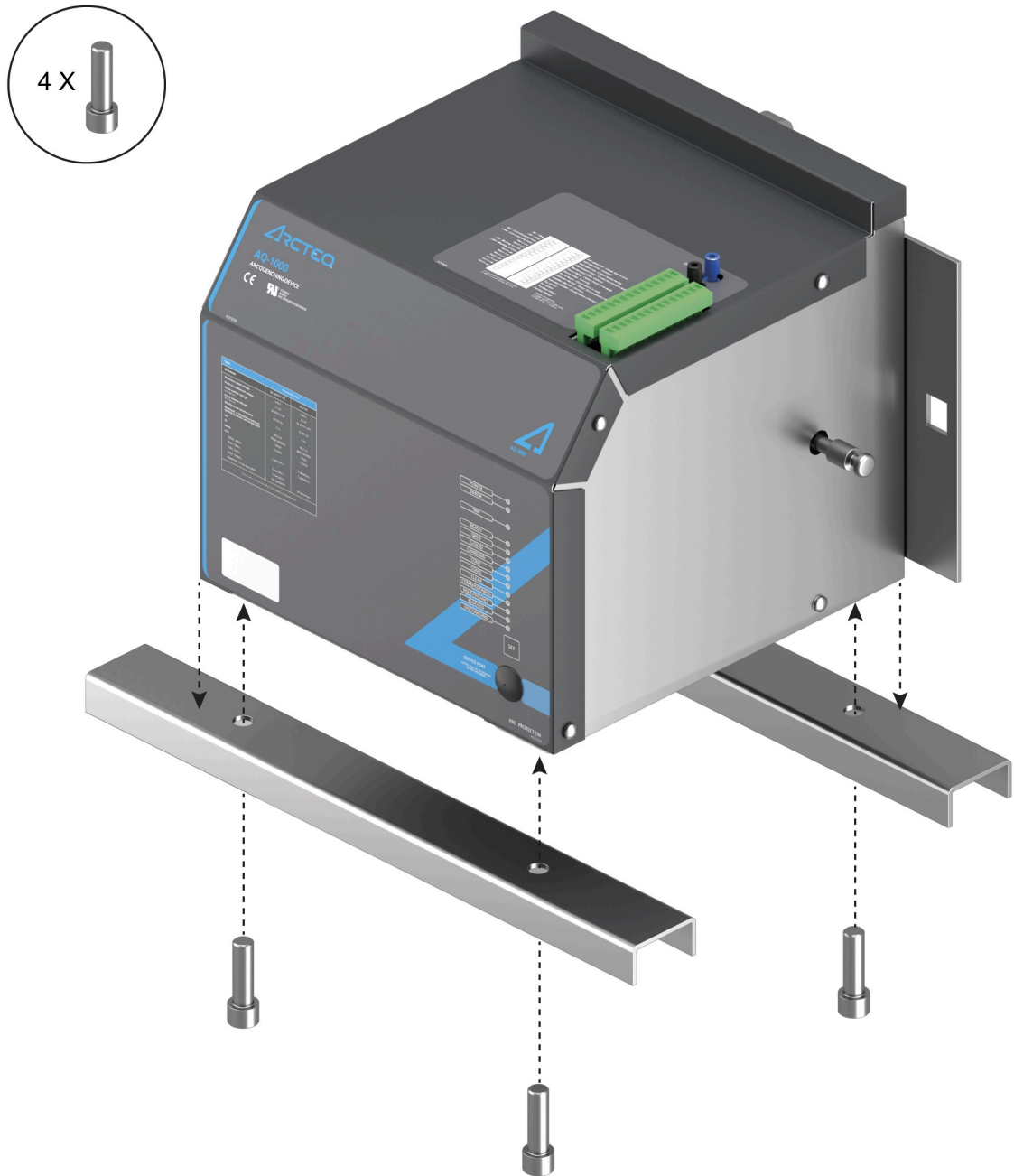
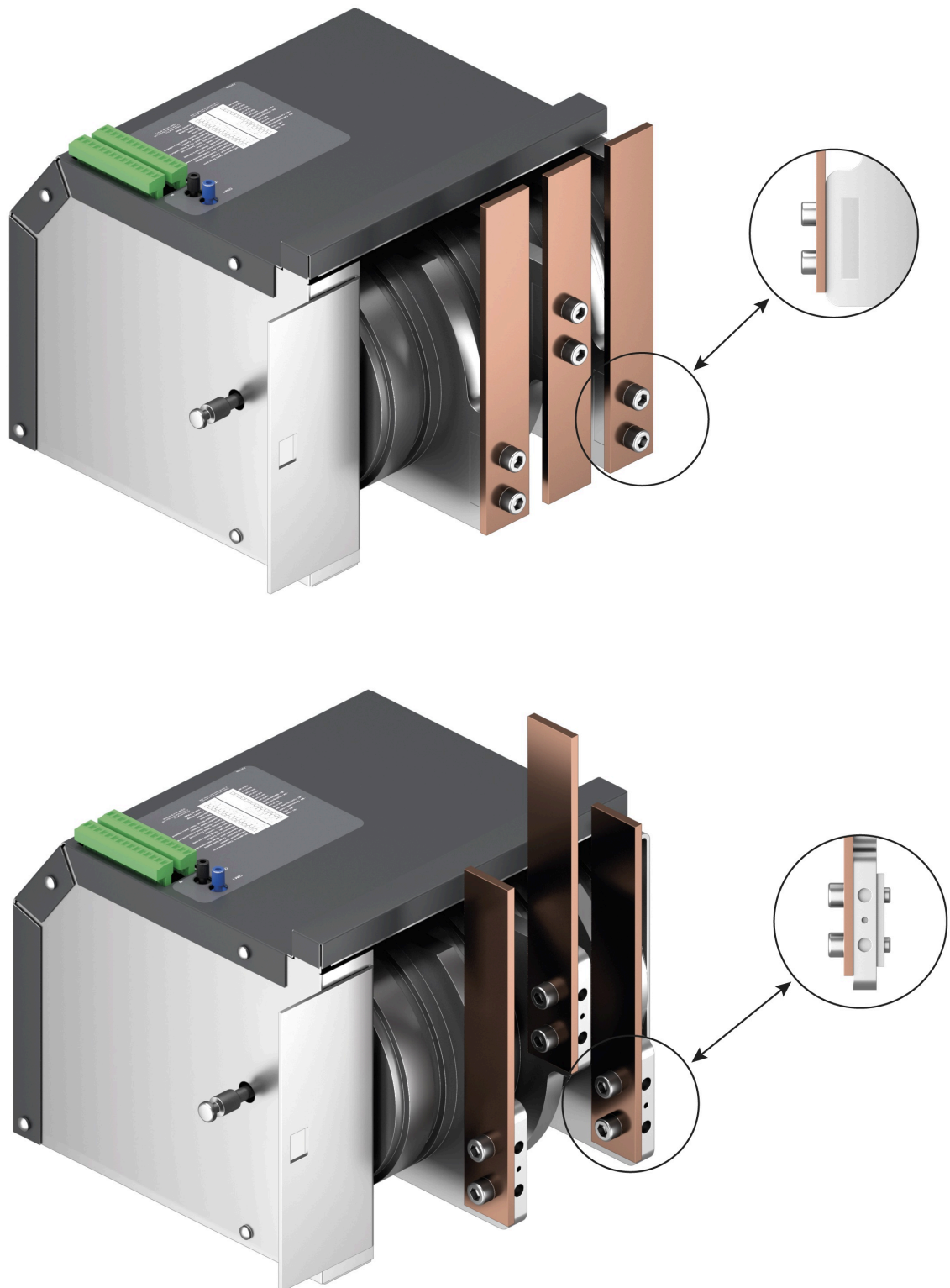

Figure. 3.2 - 8. Installation picture – busbar mounting alternatives.

**NOTICE!**

For the technical details related to installation and mounting, please refer to the [Technical data](#) chapter.



**CAUTION!**

Busbar sizing and clearance distances must be dimensioned according to switchgear ratings and the maximum short-circuit current!

### 3.3 Wiring

Description	
COM 1 – Fiber Connector; Self-Supervision and Trip Signal	COM 1
COM 2 – Fiber Connector; Self-Supervision and Trip Signal	COM 2

Description	X1	X2	Description
- Binary Input 1 – Clear			Self-supervision – Closed; System alarm
+ Binary Input 1 – Clear			Self-supervision – Common
- Binary Input 2 – Commissioning mode			Self-supervision – Closed; System healthy
+ Binary Input 2 – Commissioning mode			Maintenance alarm – Closed; Maintenance needed
Not in use			Maintenance alarm – Common
Not in use			Device Ready – Closed; Device not ready
- Binary Input 4 – Blocking function			Device Ready – Common
+ Binary Input 4 – Blocking function			Device Ready – Closed; Device is ready
Not in use			Operation Blocked – Closed; Device unblocked or Device de-energized
Not in use			Operation Blocked – Common
Not in use			Operation Blocked – Closed; Device operation blocked
Not in use			Trip contact
Not in use			Trip contact
Not in use			+ Auxiliary Supply: Option A: 85 – 265V AC / DC, Option B: 17 – 82 DC *
Not in use			- Auxiliary Supply: Option A: 85 – 265V AC / DC, Option B: 17 – 82 DC *

\* Absolute minimum and maximum values



**NOTICE!**

The image above shows the self-supervision status when the device is de-energized. The self-supervision contact changes state when the device is energized and the device recognizes the correct fiber connection.

### 3.4 Device earthing

The device earth (also known as the device ground) is connected to the device chassis. When earthing the AQ-1000 device, you should make sure that the switchgear has adequate earthing. If the device is mechanically installed on a tray, C-rail or some other structure that is properly connected to the switchgear earth, no additional earthing practices are required.

If the device is installed on a surface that is isolated from the switchgear earth, the device needs to be earthed through an additional cable to the switchgear earth. If this is the case, the earthing cable can be attached to one of the four bolts that fasten the AQ-1000 device to its mounting surface.

## 4 Device states

Mode	Definition
Charging	In Charging Mode, the device charges the energy storage to a high enough energy level as to move the contacts to the closed position. During normal operation, the charging occurs several times in an hour as the charged energy level is constantly monitored and adjusted. In this state, the LED indicators "Open" and "Charging" are on.
Ready	In Ready State, the device's energy storage has reached the optimal energy level and the device is ready to operate. In this state, the LED indicators "Ready" and "Open" are on (see the figure below).
Trip	When the device enters Trip State, the device has received a trip signal. In this state, the LED indicator "Trip" is on. If the device has operated, the LED indicator "Closed" is also on (see the figure below).
Error	When the device enters Error State, an error (or multiple errors) has occurred. In this state, the LED indicator "Error" is on. Depending on the source of the fault, one or several other LED indicators may be blinking. If the error does not resolve automatically within one minute, the device enters Discharging Mode. If the device recovers from the fault, Error State is removed and the device re-enters Charging Mode if it is not already in Ready State.
Discharging	Discharging Mode occurs when the device's auxiliary power is disconnected or if the device has been in an erroneous state for longer than one minute. In Discharging Mode, the energy storage is safely discharged. The LED indicator for Discharging Mode remains on until a safe voltage level is reached, when the indicator turns off. Discharging will also occur if the device enters a faulty state that prevents it from operating correctly. For information on the discharging time specifications, please refer to the <a href="#">Technical data</a> chapter.
Commissioning	When performing commissioning tests or periodical testing, Commissioning Mode must be activated by energizing the BI2 binary input. When in Commissioning Mode, the device can be tripped any number of times without affecting the internal trip counter.
Blocked	Blocked Mode is activated when the BI4 binary input is energized. In this state, the LED indicator "Blocked" is on. When the blocking function is active, the movement of the arc quenching contacts is prevented in case a trip signal is received.
Maintenance	Maintenance Error is generated when the device has reached the maximum number of trips. A Maintenance Alarm or Error is also generated if the device's energy capacitor has reached the end of its lifetime. Please contact Arcteq technical support for further instructions (see the <a href="#">Contact and reference information</a> chapter for details).

Figure. 4 - 9. Operating modes Ready and Trip.

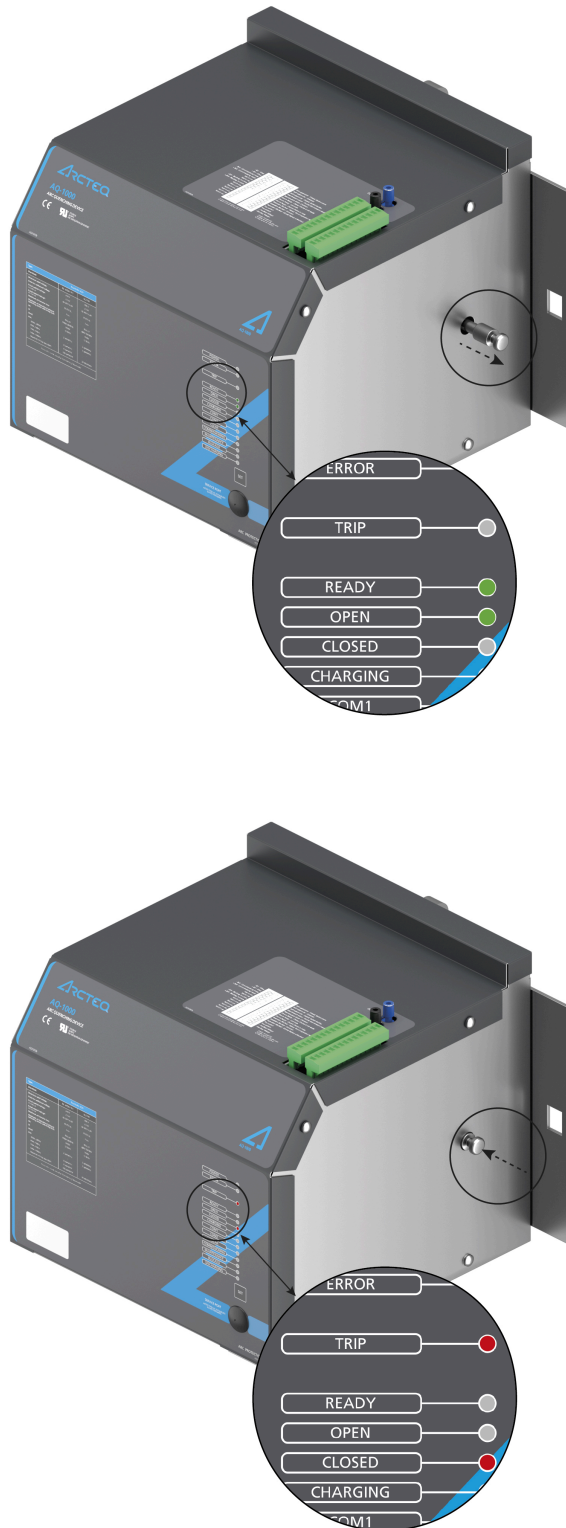

## 5 LED indicators

AQ-1000 has fourteen (14) LED indicators on its front panel for the various operating states. The following table describes them in detail.

Table. 5 - 2. LED indicators.



LED name	Color	LED is OFF	LED is ON	LED is blinking
Power	Blue	The auxiliary supply is disconnected.	The auxiliary power is connected.	There is an internal voltage error.
Error	Red	The system is healthy.	The system is unhealthy.	N/A
Trip	Red	The device has not tripped.	The device has tripped.	N/A
Ready	Green	The device is not ready to trip.	The device is ready to trip.	N/A
Open	Green	The arc quenching contacts are not open.	The arc quenching contacts are open.	The arc quenching contacts are in an error position.
Closed	Red	The arc quenching contacts are not closed.	The arc quenching contacts are closed.	The arc quenching contacts are in an error position.
Charging	Orange	The device is not charging.	The device is charging.	There is a charging error.
COM1	Green	Not in use or not installed.	The fiber connection is healthy.	The fiber connection is lost.
COM2	Green	Not in use or not installed.	The fiber connection is healthy.	The fiber connection is lost.
Clear	Green	The "Clear" input is inactive.	The "Clear" input is active.	N/A
Commissioning	Orange	The commissioning mode is OFF.	The device is in the commissioning mode.	N/A
Maintenance	Orange	No maintenance is needed.	Maintenance is needed; contact the manufacturer.	Maintenance is needed; contact the manufacturer.
Blocked	Red	The device is unblocked.	The "Blocking function" is active.	N/A
Discharging	Red	* (When the device is OFF) The energy storage has been discharged. * (When the device is ON) The energy storage is not being discharged.	The device is discharging the energy storage.	N/A



**NOTICE!**

When the "Error" LED is active, please refer to the table above for troubleshooting. All self-resolved errors are indicated by a blinking LED, in which case the "Error" LED is off.

## 6 Binary input functions

Input	Function
BI1 - Clear	Clears or resets the indications after an error or a trip event has occurred.
BI2 - Commissioning mode	<p>When the device is in the commissioning mode, it can be tripped any number of times.</p> <div style="border: 1px solid black; padding: 5px;">  <p><b>NOTICE!</b> See also the <a href="#">Arc protection system testing</a> chapter for how the BI2 binary input is used for testing and commissioning purposes.</p> </div>
BI3 – Not in use	Not in use. (Reserved for future purposes.)
BI4 - Blocking function	<p>Blocks the trip contact activation during commissioning tests or during any other circumstances where actual tripping must be prevented.</p> <div style="border: 1px solid black; padding: 5px;">  <p><b>NOTICE!</b> See also the <a href="#">Arc protection system testing</a> chapter for how the BI4 binary input is used for testing and commissioning purposes.</p> </div>

## 7 Relay functions

Relay contact	Default state	Activated state
Self-supervision	The system is not OK. The optical fiber input is faulty or missing.	The system is OK. Both optical fiber control and self-supervision are OK.
Maintenance alarm	The device does not need maintenance.	The device needs to be maintained. Contact the manufacturer.
Device ready	The device is not ready to trip.	The device is ready to trip.
Operation blocked	The device is unblocked. The quenching contacts will move when the device is tripped.	The movement of the quenching contacts is blocked by the blocking function (BI4).
Trip contact	The device has not tripped.	The device has tripped.

## 8 SET button

AQ-1000 contains a **SET** button in the front panel which is used for resetting the indicators after a Trip event and to clear resolved error signals. The **SET** button is pressed for five (5) seconds when installing fiber inputs to the COM ports.

Figure. 8 - 10. SET button.



**WARNING!**

Do **NOT** use force when pushing the button as this is likely to force the button deep inside the chassis!

## 9 Self-supervision functions: alarms and errors



### WARNING!

**All alarms must be connected** to the supervising system to guarantee the safe operation of the AQ-1000 arc quenching device!

AQ-1000 features self-supervision functions that monitor the health and status of the device. When a fault occurs, the device indicates the fault source by blinking the corresponding LED on the front panel. If the device automatically recovers from the fault, the device returns to normal operation mode on its own. However, the LED remains blinking until the fault is manually cleared, in order to make it easy to identify the source of the resolved problem.

### Error: Fiber connection lost

This error occurs when one or two fiber connections are missing from the fiber input COM ports. When installing the arc protection system, always ensure that the AQ-1000 device has a connection to the AQ-100 host device. When using a connection from two AQ-100 host devices, make sure that both COM ports are properly installed.

#### Error: Fiber connection lost, using one com port only

When a fiber connection is lost either from the COM 1 or the COM 2 port (depending on which one has been installed), the "Error" LED turns on and the "Ready" LED turns off. The corresponding fiber LED ("COM 1" or "COM 2") blinks to indicate the faulty connection channel. At the same time the self-supervision contacts change status to indicate a system alarm. After the connection is restored, the blinking COM LED can be cleared with the SET button or the "Clear" input (the BI1 binary input).

#### Error: Fiber connections lost, using both COM ports

When a fiber connection is lost from one or both of the COM ports, the "Error" LED turns on and the "Ready" LED turns off. One or both of the fiber LEDs are blinking, indicating the fault. At the same time the self-supervision contacts change status to indicate a system alarm. After the faulty connections have been restored, the blinking COM LEDs can be cleared with the SET button or the "Clear" input (the BI1 binary input).



### WARNING!

Whenever a fiber connection is lost, restore the missing or faulty fiber input to the COM port as soon as possible. When using two fibers, if the connection to one of the two ports is missing, the device **cannot be operated from ANY COM port**. Please investigate the reason for the missing signal and correct the fault. The fault can be as small as one fiber cable being damaged or bent out of shape.

### Error: Shaft position unknown

The shaft must be properly and completely reset after a trip. When the piston shaft is between the open and closed states, the "Open" and "Closed" LEDs begin to blink simultaneously. To remove the error, use the reset handle and make sure to open the shaft fully. Clear the fault by pressing the SET button.

### Error: Internal temperature out of bounds

When the temperature is above or below the device's allowed temperature range (+5...+ 70 °C, or + 41...+ 158 °F), the "Error" LED turns on and the "Ready" LED turns off. At the same time the self-supervision contacts change status to indicate a system alarm. After the temperature is within the allowed range, the device automatically switches to the normal state. This causes the "Error" LED to be switched off, the "Ready" LED to be switched on, and for the self-supervision contacts to change status to indicate a healthy system.

### Error: Capacitor temperature out of bounds

When the temperature is above or below the device's allowed temperature range (+5...+ 70 °C, or + 41...+ 158 °F), the "Error" LED turns on and the "Ready" LED turns off. At the same time the self-supervision contacts change status to indicate a system alarm. After the temperature is within the allowed range, the device automatically switches to the normal state. This causes the "Error" LED to be switched off, the "Ready" LED to be switched on, and for the self-supervision contacts to change status to indicate a healthy system.

### Alarm: Capacitor condition low

When the device's energy storage capacity drops below 90 % of the nominal value, Maintenance Mode is automatically activated. The device is still operational. The user should contact Arcteq technical support for further instructions (see the [Contact and reference information](#) chapter for details).

### Error: Capacitor condition critical

When the device's energy storage capacity drops below 85 % of the nominal value, Maintenance Mode is automatically activated. The device can no longer be used and needs maintenance in order to return to a working condition. The user should contact Arcteq technical support for further instructions (see the [Contact and reference information](#) chapter for details).

### Alarm: Capacitor lifetime spent

When the device has been in use for over ten (10) years, the device generate a maintenance alarm. This does not prevent the device from operating. When this alarm is generated, the AQ-1000 device should be replaced as soon as possible. The user should contact Arcteq technical support for further instructions (see the [Contact and reference information](#) chapter for details).

### Alarm: Device lifetime spent

When the device has been in use for over twenty (20) years, the device generates a maintenance alarm. This does not prevent the device from operating. When this alarm is generated, the AQ-1000 device should be replaced as soon as possible. The user should contact Arcteq technical support for further instructions (see the [Contact and reference information](#) chapter for details).

### Error: Maximum trips reached

When the device has performed the maximum allowed number of normal trips, Maintenance Mode is automatically activated. The device can no longer be used and must be replaced. The user should contact Arcteq technical support for further instructions (see the [Contact and reference information](#) chapter for details).



#### NOTICE!

Trips done using the *Commissioning function* do **not** count towards the maximum trips counter. Trips done using the *Blocking function* do **not** count towards the maximum trips counter. The factory default for the number of real allowed trips is two (2).

## 10 Accessories and arc protection system devices

### Accessories

The AQ-1000 device is accompanied by the following accessories:

- AX001 – Optical fiber cable
  - One (or two) per an AQ-1000 device
- AQX060C – Reset handle
  - One per an AQ-1000 device

### Arc protection system devices

AQ-1000 is an additional part of the AQ 100 arc protection system. The following devices are compatible with the arc protection system:

- Medium-voltage series of arc flash protection devices:
  - AQ-101
  - AQ-101D
  - AQ-101S
  - AQ-102
  - AQ-103
  - AQ-110P
  - AQ-110F
- Low-voltage series of arc flash protection devices:
  - AQ-101LV
  - AQ-101DLV
  - AQ-102LV
  - AQ-103LV
  - AQ-110PLV
  - AQ-110FLV
- Arc sensors (for both the LV and the MV series):
  - AQ-01 light point sensor
  - AQ-02 light and pressure point sensor
- Fiber optic sensors:
  - AQ-06 plastic fiber loop sensor
  - AQ-07 glass fiber loop sensor
  - AQ-08 glass fiber loop sensor (high-temperature applications)
- Arc sensor tester AST-02

## 11 Arc protection system testing



### NOTICE!

The total arcing time consists of the time it takes for the trip to activate and the arc to quench. The former depends on the selected arc protection application: typically, an arc protection system that is based solely on light sensing is faster than a system based on both light and current sensing. Please refer to the arch scheme of your application for more details.

### 11.1 Preparing AQ-1000 for commissioning tests

The commissioning of the AQ-1000 arc quenching device requires an entire arc protection system to be installed and configured. Please refer to the Arcteq AQ 100 series manuals and the AQ-SAS standard arc scheme manuals for more information on commissioning of the arc protection system. These are available for download on [Arcteq's website](#).



### DANGER!

When doing commissioning or similar trip tests with the device, ALWAYS enter either Commissioning Mode (activation with the BI2 binary input) or use the blocking function (activation with the BI4 binary input) before tripping! A failure to do so will result in the device entering Maintenance State prematurely, which will permanently block the device from further operation!



### WARNING!

Please verify that there is no voltage on busbars and that all feeding circuits are disconnected and locked before performing testing trips in either Commissioning Mode or while using the Blocked Signal.



### WARNING!

Always remove the handle after the device has been reset! If it is not removed, the handle may disengage from its slot as a result of a trip and thus cause harm or damage.

### Testing AQ-1000 using the commissioning function

When commissioning or testing the device, the commissioning function can be used to verify that the signal transmission to the AQ-1000 device is correct. While in this mode, the device trips normally but the trip counter does not increase. This mode can be entered by activating the BI2 binary input on the device, which turns on the "Commissioning" LED on the front of the device.

After a successful trip command has been received, the "Trip" LED indicates a successful trip and the "Closed" LED indicates that the quenching contacts have been shorted.

After a trip, press the SET button to clear the trip.



### DANGER!

Commissioning Mode must be de-activated through the BI2 binary input as soon as the commissioning process is done! A failure to de-activate Commissioning Mode after a commissioning process leaves the device open for more real-situation trips than the maximum ratings allow.

## Testing AQ-1000 using the blocking function

When commissioning or testing the device, the blocking function can be used to verify that a functioning trip signal has been transmitted to the AQ-1000 device from the connected AQ-110x sensor unit. While in this mode, the device receives a trip signal without moving the quenching contacts. Using this mode does not increase the normal trip counter. The "Trip" LED indicates that a successful trip command was received, and the "Closed" LED indicates that the quenching contacts have moved and shorted the terminals.

After a trip has occurred, the device must be mechanically reset using the provided handle. After the device has been mechanically reset, press the **SET** button to clear the trip. The device will start charging again and will be ready for operation in approximately three minutes.

When the blocking function (the BI4 binary input) is energized, the commissioning trip can be performed without an actual quenching operation. The "Trip" LED indicates that a successful trip command was received, but the contacts have not moved and the device remains in the open position.

It is also recommended to perform one or more actual trips without the blocking function in use in order to verify that the main contacts function properly. The user should activate Commissioning Mode by energizing the BI2 binary input, which blocks the functionality of the internal operation counter. Always de-energize the blocking function input (BI4) after the tests are finished.



### DANGER!

If the blocking function (BI4) is used for commissioning tests, the signal must be de-activated as soon as the commissioning or testing process is over! A failure to do this prevents the device from closing the quenching contacts in the event of a real arc flash, which can lead to catastrophic damages and injury to personnel.

## 11.2 Testing individual arc sensors

The functionality of the sensors can be verified by tripping the individual sensor and then inspecting the connected AQ 100 series arc flash protection device. If the corresponding LED indicator on the front panel is lit, the arc sensor in question has registered the flash and is therefore functional. Additionally, this procedure can also be used to confirm that the sensor's wiring is correct.

AQ-01 light sensors can be activated by a standard camera flash. Please note that AQ-02 light-pressure sensors require the AST-02 arc sensor tester for simultaneous injection of light and pressure for activation.

## 11.3 Testing the full arc protection system

The testing procedure described in this chapter is for a complete arc protection system with individual sensors, connected arc protection devices, and the AQ-1000 arc quenching device. All system components are tested. Devices that require both light and current activation must use an additional current injection device to trip the AQ 100 series device. For this purpose, current injection and control devices that are used for protection devices are also suited for testing the arc protection system. These commissioning devices can also be used to remotely control the arc sensor tester AST-02 for exact timing of the current and light activation.



### NOTICE!

The selected standard arc scheme (SAS) describes which arc protection device trips the AQ-1000 device and under what conditions the trip occurs. The host device might not trip the AQ-1000 device with light sensor activation (L>) alone, as it may require a current activation (I>) signal as well. Please refer to your chosen arc scheme for more details in the AQ-SAS manual, which can be downloaded on [Arcteq's website](#).

**NOTICE!**

Applications that rely only on sensor activation for tripping the breakers (as well as the AQ-1000 arc quenching device) can use AST-02 to complete a full test on the arc protection system.

## Overview

Arc flash protection systems are designed to detect and mitigate arc faults quickly, ensuring personnel safety and minimizing damage to equipment. A full system includes the following components:

- **Arc flash protection device** (for example, AQ-110P) equipped with a fiber optic sensor loop to detect the intense light from arc flash events. The device also includes an internal filter time to prevent nuisance tripping from electromagnetic compatibility (EMC) or transient disturbances.
- **Arc quenching device** (for example, AQ-1000) extinguishes an arc fault by creating a low-impedance path. The AQD includes a filter time to validate the arc condition before activation.
- **Circuit breakers**, controlled by the arc protection device, isolate the faulted section of the system.
- **Fiber optic sensors** are installed in switchgear compartments to detect light from arc flashes.

The purpose of testing the system is to verify the following:

- The arc protection device correctly detects a simulated arc flash.
- The arc protection device's output triggers the designated circuit breakers.
- The AQD activates as designed.
- The system meets the required response time and filter logic.

Successful testing requires the following items:

- **Current injection test kit** simulates overcurrent conditions.
- **Professional camera flash unit** (for example, [Nissin Di700](#)) that can produce a high-intensity light pulse with a sufficient duration, used to ensuring the system exceeds the filter times set for the arc protection device and the AQD.
- **Multimeter** or **relay test set** verifies output contacts and breaker trip signals.
- *(optional)* **Oscilloscope** or **data logger** captures the time for device activation and breaker operation.

## Testing procedure

**NOTICE!**

Remember to document all test results according to best practice!

**CAUTION!**

Read these instructions **before** beginning the testing procedure!

### Step 1: Preparation

- Verify that the system settings (= trip logic) match the testing parameters.
- Make sure that the system is de-energized and isolated. Make sure that the system cannot become energized during the testing procedure!
- Connect the fiber optic sensor loop to the arc protection device.
- Make sure that the camera flash unit is aligned properly with the fiber optic sensor.
- Confirm that the arc quenching device (AQD) is armed and connected to the arc protection device.
- Verify that the current injection test kit is properly configured and connected to simulate a fault current.

### Step 2: Simulating an arc flash

- Use the camera flash unit to emit a high-intensity light burst directly into the fiber optic sensor. At the same time, inject a simulated fault current to mimic real arc fault conditions.
- Make sure that the flash duration is longer than the combined filter times of the protection device and the quenching device (typically  $>1,200 \mu\text{s}$ ).
- Make sure that the protection device's AQD channel activates the coded signal pattern and that the pattern passes the AQD's internal filter for the activation. The AQD's LEDs and activation signalize when received fully.

### Step 3: Observing the system response

- Monitor the arc protection device's trip output.
- Confirm that the device trips and sends a signal to open the designated circuit breakers.
- Confirm that the AQD closes to extinguish the arc fault.
- Confirm that the response time is within the system's design parameters.

### Step 4: Reset and repeat

- Reset the arc protection device and the AQD.
- Repeat Steps 1 through 3 for all sensor loops and breaker outputs according to the system design. Please note that it is not necessary to trip the AQD or the circuit breakers from each sensor if they belong to the same arc protection device and the same zone.
- Test every sensor and monitor the activation of the LEDs in the arc protection device and the AQD.

## Passing criteria

A full arc fault protection system test is considered successful when all of the following criteria are filled:

- The light signal from the arc flash is detected and sustained long enough to pass the protection device's filter time.
- The arc protection device issues a trip command within the expected time frame.
- All designated circuit breakers operate according to the protection scheme.
- The AQD activates and closes correctly.
- Short or insufficient light pulses do **not** cause any nuisance trips.

The two figures below show two system test results with light intensity in relation to time. In the first figure the test has been successful: the length of the continuous light source passes all internal filters. In the second figure the test has failed: while the light intensity has been enough, it dips below the threshold level before reaching the AQD pulse receive ("Receiver Confirmation")

Figure. 11.3 - 11. Successful system test with AQD.

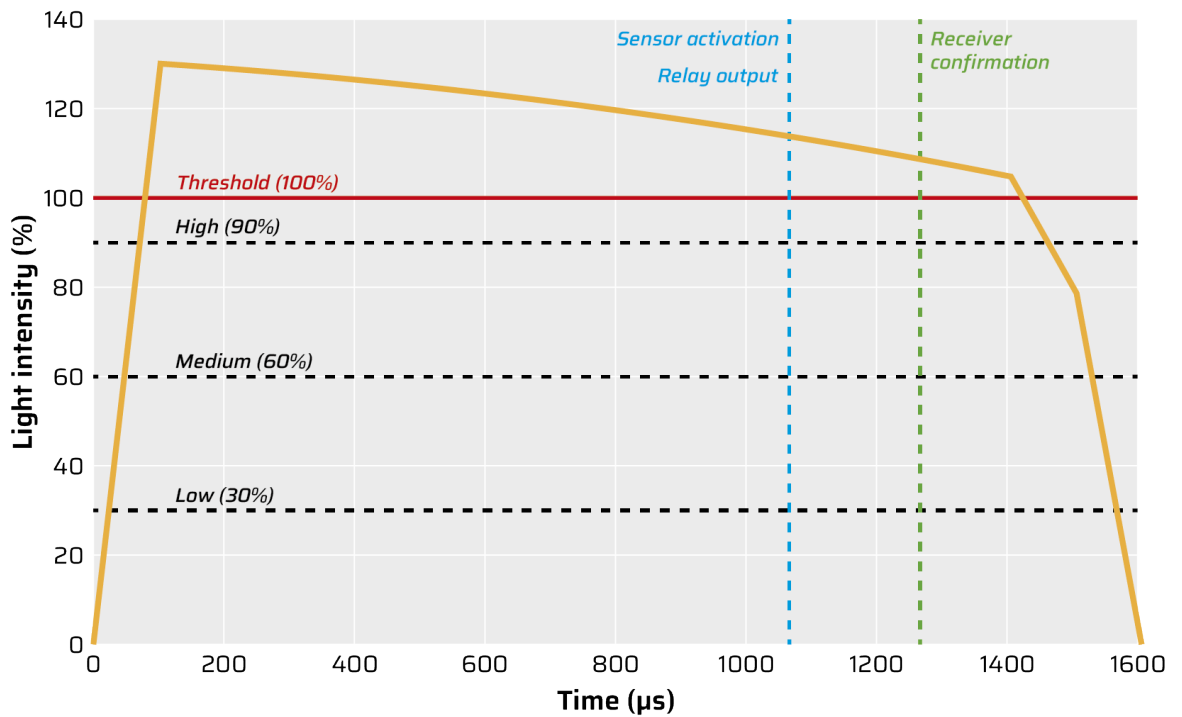
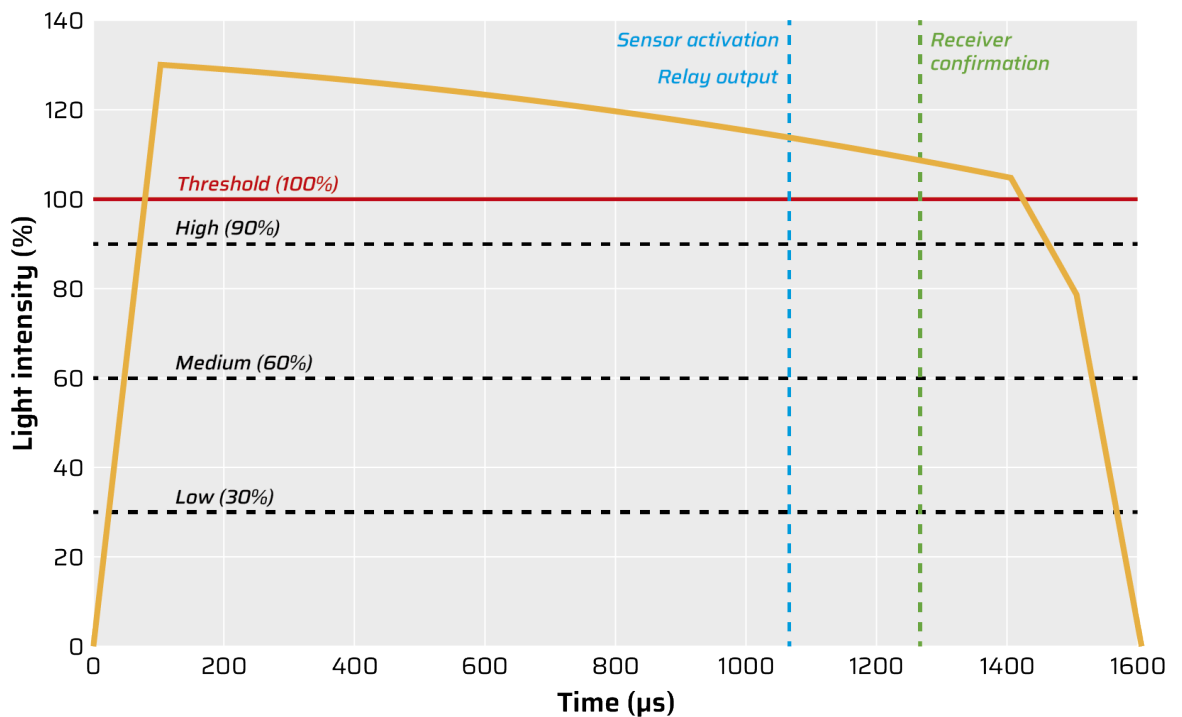

Figure. 11.3 - 12. Failed system test with AQD.



## 11.4 Testing with arc sensor tester

The AST-02 arc sensor tester can be used to test the following sensors and features:

Arc sensor	AQ-02 activation (both light and pressure)
------------	--

Arc sensor	AQ-01 activation (only light)
Arc sensor	Options for light element sensitivity threshold: 8 klx, 25 klx, and 50 klx
Arc flash protection device	Normal sensor trip and breaker activation
Arc flash protection device	Breaker activation + CBFP function (first and second stage)
Control	Local or external control device

## 11.5 Restoring the quenching contacts

After an arc flash incident has occurred, the restoration of the arc protection system and the quenching device must be done carefully and systematically. Always follow national guidelines, safety policies, and regulations as well as the instructions of the equipment manufacturer.



### WARNING!

Locate and remove the cause of the fault and repair any possible damage caused by the arc flash! The system must be verified to be in normal operating condition before the quenching contacts are restored.

- Restore the device contacts to the open position by using the reset handle (see the figure below).
- Reset and clear all indicators in the arc protection system with the **SET** buttons.



### CAUTION!

It is recommended to use the "Ready" contact of AQ-1000 as the lock-out signal for the circuit breaker. This prevents the closed operation of the circuit breaker while the AQ-1000 device is in the closed position or otherwise not ready to operate.

When a trip has occurred, the quenching contacts must be restored to the open position by using the handle provided with the device (see the figure below). Reset the device by connecting the handle to the reset shaft. Then, gently but firmly press the handle to the right. When the reset shaft has moved slightly, move the handle to the next handle position. Repeat until the device "snaps" completely open. Then, press the **SET** button. The device's LED indicators show that the contacts are now in the open position.

Figure. 11.5 - 13. Resetting contacts.

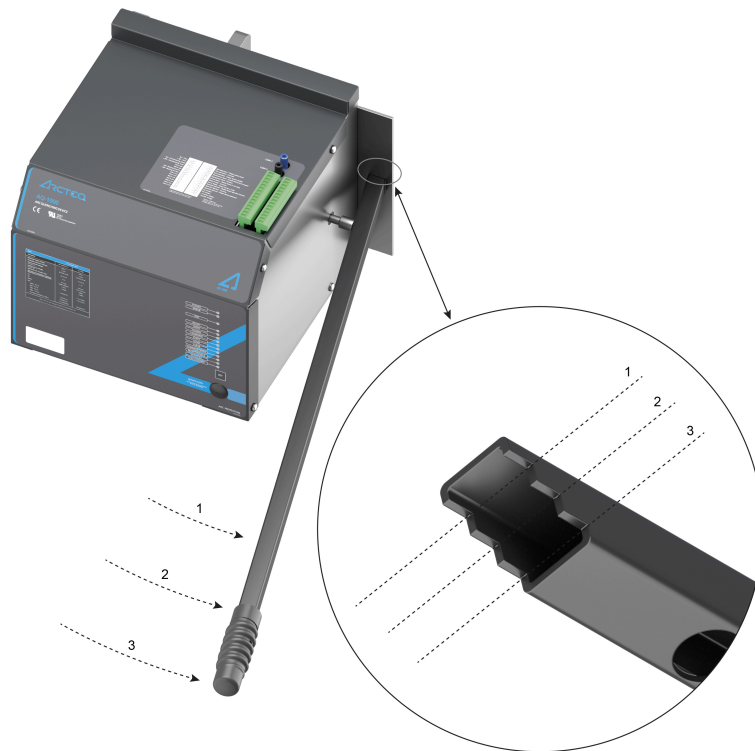
**WARNING!**

Always remove the handle after the device has been reset! If it is not removed, the handle may disengage from its slot as a result of a trip and cause harm or damage.

**WARNING!**

Never attach the handle to the device when the device is in the open position!

## 12 Application example

This chapter demonstrates one example how an arc protection system can be set. Please refer to the individual AQ 100 series device manuals as well as the AQ-SAS (standard arc scheme) manuals for more information regarding the various arc protection system schemes and applications. You can find all the SAS manuals for both MV and LV systems on [Arcteq's website](#).

This example is for a selective Main-Tie-Main configuration. Its trip logic is explained in the table below, while the image below the table shows its connections.

Arc in compartment	AQ-1000	Primary side incomer	Secondary side incomer	Feeder 1	Feeder 2	Feeder 3	Tie breaker
Incomer CB cable compartment	No	Yes	Yes	No	No	No	No
Incomer CB breaker compartment	No	Yes	Yes	Yes	Yes	Yes	Yes
Busbar compartment	Yes	No *	Yes	Yes	Yes	Yes	Yes
Feeder 1 cable compartment	No**	No	No**	Yes	No	No	No**
Feeder 2 cable compartment	No**	No	No**	No	Yes	No	No**
Feeder 3 cable compartment	No**	No	No**	No	No	Yes	No**
Tie breaker compartment	Yes	No *	Yes	Yes	Yes	Yes	Yes

\*) The circuit breaker of the high-voltage side is tripped when the circuit breaker failure protection is activated. Please refer to the individual AQ 100 series device manuals and the AQ-SAS manuals for more information regarding circuit breaker failure protection.

\*\*\*) AQ-1000, the secondary side incomer, and the tie breaker are tripped when the circuit breaker failure protection is activated. Please refer to the individual AQ 100 series device manuals and the AQ-SAS manuals for more information regarding circuit breaker failure protection.

Figure. 12 - 14. Connections of the example application.

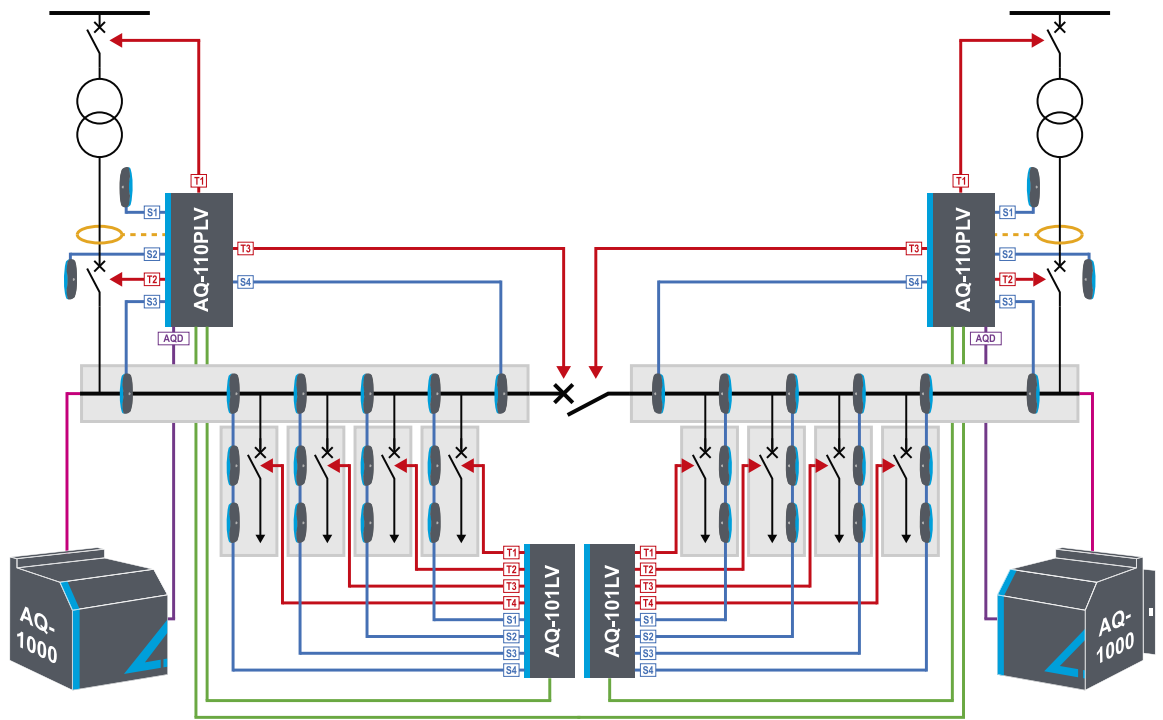

## 13 Technical data

### 13.1 Mounting and installation

Table. 13.1 - 3. Technical data for mounting and installation.

Tray	
Tray material	Steel tray plate
Tray thickness (recommended minimum)	3.0 mm (0.118")
C-rail	
C-rail material	Steel rail
C-rail material thickness (recommended minimum)	2.0 mm (0.079")
Device mounting	
Screw type	ISO 4762 M8x30, galvanized
Key size	Allen key 6
Tightening torque (min...max)	20...25 N·m (177...220 lbf·ft)
Burbar mounting	
Screw type	ISO 4762 M8x30, galvanized
Key size	Allen key 6
Tightening torque (min...max)	20...25 N·m (177...220 lbf·ft)
Connectors (X1 and X2)	
Wire cross section (solid and multicore) (min...max)	0.2...2.5 mm <sup>2</sup> (24...13 AWG)
Minimum stripping length	7 mm (0.275")
Screw tightening torque (min...max)	0.5...0.6 N·m (4.4...5.3 lbf·ft)
Connectors (fiber)	
Fiber connectors	IF-D91B
Fiber type	Arcteq AX-001 multicore glass fiber

### 13.2 Device ratings

Table. 13.2 - 4. Technical data for AQ-1000.

Maximum busbar voltages (line-to-line)	
IEC rating	690 V AC 50/60 Hz Power frequency withstand voltage 1000 V AC

UL rating	508 V AC 50/60 Hz
<b>Maximum short-circuit currents</b>	
IEC rating	100 kA (200 ms, 2 operations) 75 kA (500 ms, 3 operations) 50 kA (1 s, 4 operations) 25 kA (2 s, 5 operations)
UL rating	100 kA (200 ms, 2 operations) 85 kA (500 ms, 2 operations)
<b>Additional information</b>	
Operation time	<2 ms
Basic insulation level (phase contacts)*	12 kV
AC dielectric voltage withstand (phase contacts)*	2.2 kV AC 50/60 Hz
Typical charging time of the energy storage (empty to full)	<5 minutes
Typical discharge time of the energy storage (full to empty, when auxiliary power is disconnected)	<15 minutes
<b>Dimensions and weight</b>	
Device dimensions	Please see <a href="#">Device dimensions</a> chapter for detailed device dimensions.
Weight (gross)	15.7 kg (34.6 lbs)
Weight (net)	15.0 kg (33 lbs)

\*) For other circuits please see the following chapters.



**NOTICE!**

The total system operation time is typically <4 ms (AQ-110P + AQ-1000). Power system studies which incorporate the Arcteq AQ-1000/AQ-110P system should use a clearing time of 5 ms for all assets protected by this system.

### 13.3 Auxiliary voltage

Table. 13.3 - 5. Technical data for the auxiliary power supply options.

<b>Option A</b>	
U <sub>s</sub> (min...max)	85...265 V AC/DC
U <sub>s</sub> (nominal)	110, 220 V DC 110, 115, 220, 230 V AC, 50/60 Hz
Impulse voltage withstand	5 kV (1.2 μs)
AC dielectric voltage withstand	2 kV (50 μs)
<b>Option B</b>	

U <sub>s</sub> (min...max)	18...72 V DC
U <sub>s</sub> (nominal)	24, 36, 48, 60 V DC
Impulse voltage withstand	1 kV (1.2/50 µs)
AC dielectric voltage withstand	450 V

Table. 13.3 - 6. Technical data for auxiliary voltage (both range options).

Maximum interruption in ready operating mode	100 ms
Maximum power consumption	5 W (standby, device ready) 11 W (device charging)

## 13.4 Output relays

Table. 13.4 - 7. Technical data for output relays (Trip, Ready, Blocked, Maintenance, IRF).

Voltage withstand	250 V AC/DC
Carry: - continuous carry - make-and-carry for 3 s - make-and-carry for 0.5 s	5 A 16 A 30 A
Breaking capacity DC*	40 W (0.36 A at 110 V DC)
Contact material	AgNi 90/10

\* When the time constant L/R = 40 ms.

## 13.5 Binary inputs

Table. 13.5 - 8. Technical data for binary inputs.

Nominal threshold voltage (min...max)	24 V DC (range 24...250 V DC)
Threshold: - pick-up - drop-off	Approximately 16 V DC Approximately 15 V DC
Rated burden	3 mA



### WARNING!

The binary inputs are galvanically isolated from the device earthing. Attention must be paid to avoid galvanic loops via binary input earth!

## 13.6 Voltage tests

Table. 13.6 - 9. Technical data for the voltage tests.

Insulation test voltage (IEC 60255-5)	2 kV, 50 Hz, 1 min
Impulse test voltage (IEC 60255-5)	5 kV, 1.2/50 $\mu$ s, 0.5 J

## 13.7 Environmental ratings

Table. 13.7 - 10. Environmental ratings.

Environmental operating temperature (min...max)	5...70 °C (41...158 °F)
Humidity (max)	95 % RH, no condensation allowed
Storage temperature (min...max)	-40... 85 °C (-40...185 °F)

## 14 Ordering information

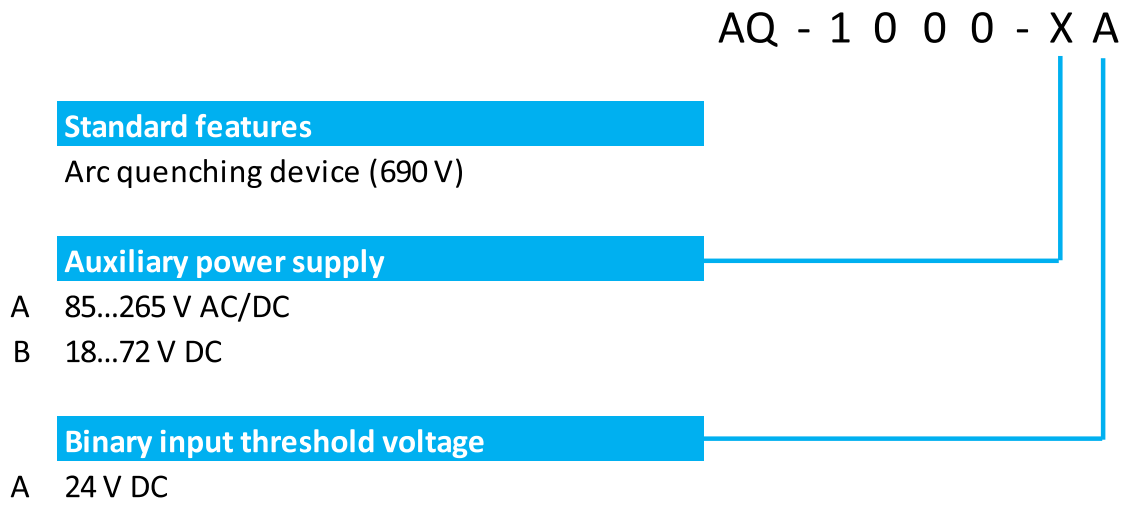

Table. 14 - 11. Accessories.

Order code	Description
AX001-3	Connection fiber, 3 meters
AX001-5	Connection fiber, 5 meters
AX001-10	Connection fiber, 10 meters
AX001-20	Connection fiber, 20 meters
AQX060C	Additional reset handle

## 15 Contact and reference information

### Manufacturer

Arcteq Relays Ltd.

### Visiting and postal address

Kvartsikatu 2 A 1  
65300 Vaasa, Finland

### Contacts

Phone:	+358 10 3221 370
Website:	<a href="http://arcteq.com">arcteq.com</a>
Technical support:	<a href="http://arcteq.com/support-login">arcteq.com/support-login</a> +358 10 3221 388 (EET 9:00 – 17.00)
E-mail (sales):	<a href="mailto:sales@arcteq.com">sales@arcteq.com</a>