



AQ 200 SERIES

PROTECTION, CONTROL, MEASUREMENT,
AND MONITORING DEVICES

ANSI



AQ 200 SERIES

**PROTECTION, CONTROL, MEASUREMENT,
AND MONITORING DEVICES**

BENEFITS OF THE AQ 200 SERIES	3	AQ 250 SERIES	43
ARCTEQ INNOVATIONS	4	➤ AQ-F255 Feeder protection device.....	43
➤ The most accurate protection relay in the world.....	4	➤ AQ-M255 Motor protection device.....	45
➤ Intermittent ground fault protection.....	5	➤ AQ-M257 Motor protection IED.....	46
➤ Broad-range ground fault detection with multiple criteria.....	6	➤ AQ-G257 Generator protection device.....	47
➤ Disturbance recorder and power quality.....	7	➤ The generator commander.....	48
➤ Cable-end differential protection.....	8	➤ AQ-M257C Motor commander.....	49
➤ AQ-S254A - A new generation of alarm annunciators.....	9	➤ AQ-V251 Voltage protection device.....	50
➤ Gateway in arc protection schemes.....	10	➤ AQ-C255 Capacitor bank protection device.....	51
➤ AQ-C255 The power factor controller.....	11	➤ AQ-T256 Transformer protection device.....	53
AQTIVATE 200	12	➤ AQ-T257 Transformer protection device.....	54
➤ Setting and configuration software.....	12	➤ AQ-S254 Alarm and indication device.....	56
AQ 200 PROTECTION FUNCTIONS	14	➤ AQ-S255 Bay control device.....	57
AQ 200 CONTROL AND MONITORING FUNCTIONS	21	SELECTION TABLE	58
AQ 210 AND AQ 250 SERIES PROTECTION AND CONTROL DEVICES	25	LIST OF AVAILABLE OPTION MODULES	62
AQ 210 SERIES	26	ACCESSORIES 210	63
➤ AQ-F201 Feeder protection device.....	26	➤ Raising frame.....	63
➤ AQ-F205 Feeder protection device.....	27	➤ Wall-mounting bracket.....	63
➤ AQ-F210 Feeder protection device.....	28	➤ COMBIFLEX frame.....	63
➤ AQ-F213 Feeder protection device.....	29	ACCESSORIES 250	64
➤ AQ-F215 Feeder protection device.....	31	➤ Raising frame.....	64
➤ AQ-M210 Motor protection device.....	32	➤ Wall-mounting bracket.....	64
➤ AQ-M215 Motor protection device.....	33	TECHNICAL DATA	65
➤ AQ-G215 Generator protection device.....	34	➤ Hardware.....	65
➤ AQ-V211 Voltage protection device.....	35	➤ Protection functions.....	68
➤ AQ-C215 Capacitor bank protection device.....	36	➤ Control functions.....	80
➤ AQ-T215 Transformer protection device.....	37	➤ Monitoring functions.....	82
➤ AQ-T216 Transformer protection device.....	38	➤ Environmental tests.....	84
➤ AQ-S214 Alarm and indication device.....	39	EXAMPLE WIRING	85
➤ AQ-S215 Bay control device.....	40	INSTALLATION AND DIMENSIONS 210	86
➤ AQ-P215 Power monitoring device.....	41	INSTALLATION AND DIMENSIONS 250	87
➤ AQ-R215 Railway protection device.....	42	NOTES	88

BENEFITS OF THE AQ 200 SERIES

The AQ 200 series provides an optimal protection for any electrical protection and control application, from utilities and power plants to wind power and heavy industry applications (offshore, marine) as well as industrial and commercial electrical systems. The series offers both integrated and segregated solutions that include complementary and powerful monitoring, measuring, communication, and diagnostics information.

The AQ 200 series is an umbrella designation which includes two levels of protection relays: the AQ 210 series offers cost-effective solutions to less complex applications, while the AQ 250 series is ideal for more demanding applications that require a more integrated functionality with a possibility for additional I/O or communication expansion.

All devices are modular as well as easy and fast to configure. The latest technologies give protection and control engineers new options and open a whole new dimension of protection and control!

AQ 200 benefits

VERSATILE PROTECTION DESIGN

The AQ 200 series is characterized by fast, versatile, and dependable protection functions with a uniquely wide operating frequency band (6...75 Hz). This makes AQ 200 devices a perfect choice for even the most demanding protection applications, including rotating machines.

MODULARITY

The fully modular hardware construction of AQ 200 series devices allow for a high level of flexibility. Existing devices can be augmented with additional I/O or communication modules according to application needs by simply plugging them in.

USABILITY

Various features guarantee that users get the maximum use out of their devices. AQ 200 devices

include guided wizards, sophisticated setting aids, highly customizable HMI, file storage of supportive documents, and extensive user log information. The devices also have a complete user history registry with setting changes and other operational history.

PERFORMANCE

The 200 series offers truly fast trip times, instantaneous and sub-cycle! A fast and integrated module can be added to include arc protection in your more traditional protection schemes. Powerful PLC programming is included to allow for extensive customization for the most demanding application. Up to 100 10-second disturbance records and up to 10,000 events can be stored in the non-volatile memory.

COMMUNICATION

Native Ethernet communication provides fast and seamless communication. AQ 200 devices communicate using a variety of standard

protocols, including the IEC 61850 substation communication standard with fast GOOSE messaging. All AQ 250 series devices have been certified for the 2nd Edition of the IEC 61850 communication protocol!

SAVINGS IN ENGINEERING TIME

The AQtivate 200 setting and configuration software saves valuable engineering time by offering an intuitive HMI that is easy to use and free of charge. You can download all relay settings instantly into the device with the native 100 MB/s Ethernet connection.

STANDARDIZED HARDWARE

The highly standardized hardware design provides trouble-free logistics and storage. Each AQ 200 device includes five CT inputs and a CPU module with a set of digital I/O, as well as an RJ-45 port in the front and the rear of the device.

The most accurate protection relay in the world

ACCURATE AND INDEPENDENT OF FREQUENCY

Arcteq's AQ 200 series of protection and control devices uses our patented measurement technology which provides a unique combination of characteristics. With a power and energy measurement accuracy of 0.2 %, a single device has a full and dynamic measurement range as well as measurement and protection independent of frequency.

The AQ 200 series provides an optimal protection and control solution for any utility.

This makes AQ 200 series devices well suited for any application that only requires accurate measurement, or one that needs a combination of measurement and protection. Additionally, our frequency-independent measurement technology allows for more accurate protection for rotating machines.

PATENTED MEASUREMENT ALGORITHM

AQ 200 devices adjust the sample rate of the measurement channels according to the measured system frequency, and do so in a way that allows FFT calculations to always make use of the full power cycle buffer. With this method devices can achieve a measurement accuracy that is independent from the system frequency.

All analog channels are also calibrated against eight system frequency points (both magnitude and angle). This frequency-dependent correction compensates the frequency dependencies present in the measurement hardware in use, and is needed because the hardware used for measurements is not linear with regards to the measured analog signal frequency. A high accuracy therefore requires that the magnitude and angle measurements are calibrated against frequency. Additionally, the fundamental frequency component from the measured channel's FFT result is corrected for magnitude and angle errors by our patented calibration algorithms.

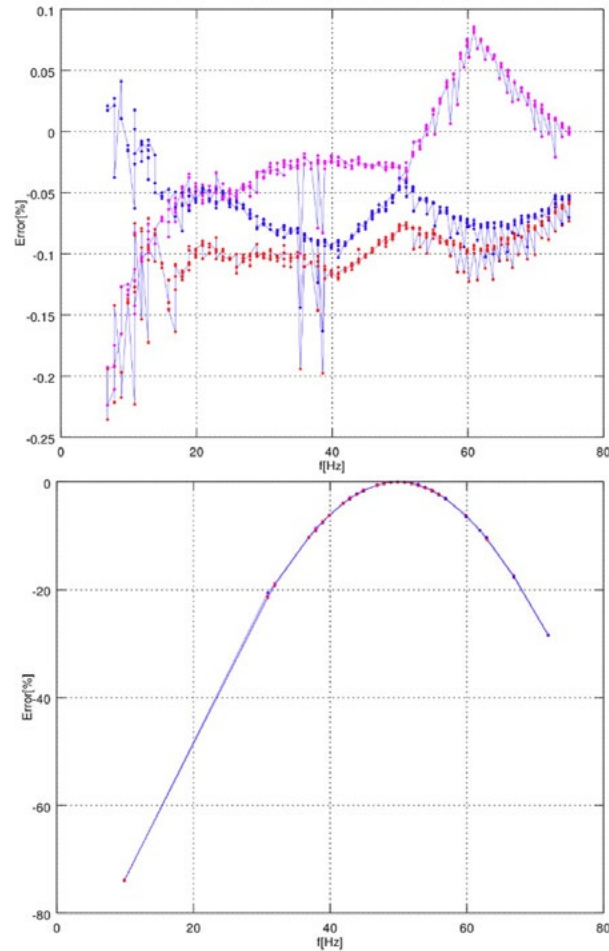

The frequency tracking functionality keeps the measurement accuracy in Arcteq protection devices with 0.2 % between 6 and 75 Hz.

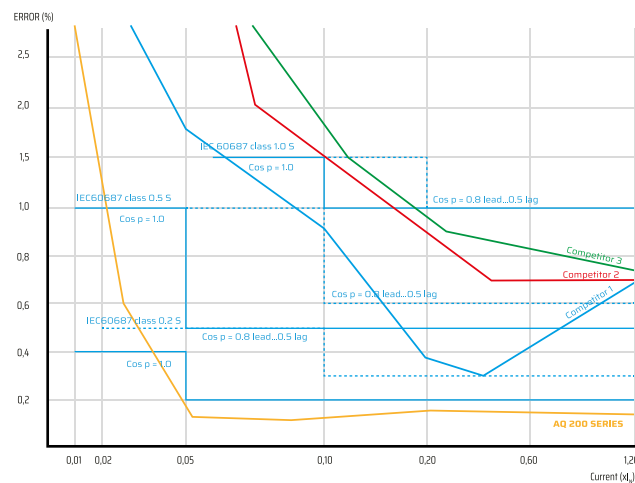

The measurement accuracy in AQ 200 devices remains within 0.2 % even at extremely low currents

Intermittent ground fault protection

BACKGROUND

While underground cabling makes distribution networks less vulnerable to disturbances, they also lead to higher ground fault currents. Compensating networks with Petersen coils keep the ground fault currents lower. A typical intermittent ground fault is a self-extinguishing flash-over fault (phase-to-earth) lasting 0.05...1.00 ms. This causes heavy transient spikes in the electrical network. Traditional directional ground fault protection, designed for non-intermittent faults, is usually grounded on FFT-processed (Fast Fourier Transformation) results which in turn are based on the RMS values of the fundamental frequency. This makes traditional protection unable to operate correctly during intermittent faults.

PATENTED SOLUTION

Arcteq's patented measurement technology is the foundation for our accurate algorithms that can protect against intermittent ground faults. By combining very accurate measurements (especially for energy and power) with a 3.2-kHz sampling rate, the algorithms search for spikes generated by intermittent ground fault strikethroughs in the fundamental frequency components I_0 and V_0 . The algorithms can cut through all unnecessary data and concentrate on the spikes: they determine the polarity of the spikes by calculating the delta in raw sample values, and with the help of our innovative and patented admittance-based formula, they can detect and isolate the fault with high accuracy.



AQ-F215 for feeder protection is one of our devices equipped with the intermittent ground fault protection function.

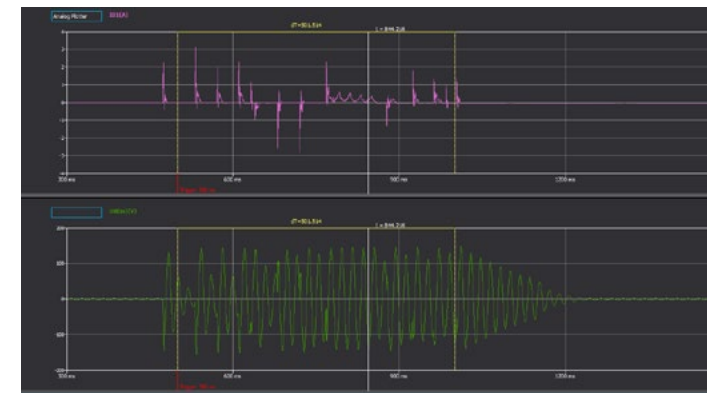

These example graphs show that the intermittent ground fault protection has worked as intended: the function's trip time has been set at 500 ms, and both graphs show that the device has detected the fault and tripped within that time.

Extensive field tests have proven our algorithms effective. The first AQ 200 devices equipped with the intermittent ground fault function were installed in 2014, and more have been installed in various networks ever since.



Testing the algorithms in the field in 2014 with VSV, an energy company located in southwestern Finland.

Broad-range ground fault detection with multiple criteria

BACKGROUND

An increasing amount of medium-voltage cabling as well as blending distributed generation and compensated networks into distributed compensation have led to new challenges in ground fault protection for distribution feeders. More and more, distribution system operators are using complex combinations of short cable feeders, long overhead feeders, and mixed cable and overhead networks. In these systems, relying on conventional protection methods may lead to various problems, such as healthy feeders nuisance-tripping, and actual faults going undetected.

If the protection of compensated long-distance cables and overhead lines is based only on measuring the angle and magnitude of residual voltage and currents, it can be very difficult to tell the difference between healthy and faulty feeders. Often, ground fault protection requires information about the network's status: is the network isolated or compensated? When changing between the two statuses, the setting groups must also be changed, and this may be difficult or downright impossible in the case of compensated distribution networks.

NEW BROAD-RANGE MODE WITH MULTI-CRITERIA DETECTION

The solution to this problem is Arcteq's new broad-range mode. Available in the AQ 200 series, it can protect against ground faults in both unearthed and compensated networks without setting changes. The algorithm is made even more reliable by our new multi-criteria detection. This optional additional tripping condition for compensated network uses our patented intermittent ground fault algorithm, and supplements it by calculating the symmetrical components for phase currents and voltages. If this additional mode is activated, the tripping criteria include the residual current (measured in the third or fourth quadrant) as well as the symmetrical components of voltages and currents that detect a fault. Unlike the traditional method, no additional parameter defining is required.

You can test the multi-criteria algorithm with COMTRADE files supplied by Arcteq. The algorithm function requires a combination of three-phase currents, the residual current, and the zero sequence voltage to operate correctly. Additionally, you can add an encroachment area in compensated, long, healthy feeder lines: this helps you avoid unnecessary trips that errors in current transformers can cause. The broad-range mode with multi-criteria detection together with the intermittent ground fault protection function provide feeders in compensated networks complete coverage against ground faults.

The solution to the problem is Arcteq's new broad-range mode. Available in the AQ 200 series, it can protect against ground faults in both unearthed and compensated networks without setting changes.

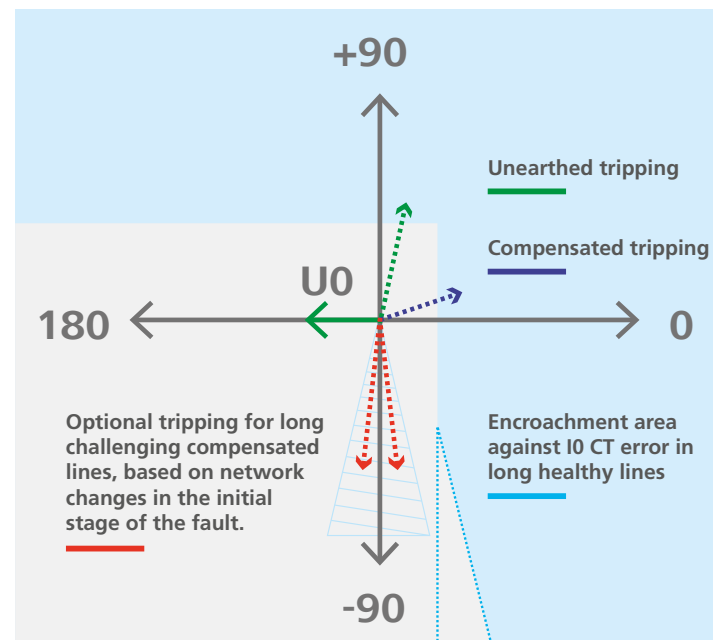

Operation of the new broad-range mode with multi-criteria detection increases protection reliability.

Disturbance recorder and power quality

DISTURBANCE RECORDER'S CAPACITY

The disturbance recorder in AQ 200 series devices is a high-capacity and fully digital recorder that is integrated into the device. The recorder supports 96 digital channels and 8 measured analog channels. The maximum sample rate for analog channels is 64 samples per cycle, but all measured and calculated values can be registered as digital channels with a 5-ms sample time. This feature is especially useful during a motor's start-up sequence, as users can track both the fully sampled analog waveform values and the RMS values sampled every 5 ms at the same time. Thanks to the notable memory capacity, devices can store up to 100 non-volatile records: a full sample rate and the maximum number of recorded channels result in a total of 500 seconds of recording time. The records are saved as COMTRADE files (based on the IEEE C37.111 standard), which makes them compatible with most viewers and relay test sets.

DOCUMENTING VOLTAGE SAGS AND SWELLS WITH THE DISTURBANCE RECORDER

The AQ 200 series disturbance recorder is a great tool for analyzing the performance of the power system in network disturbance situations. Voltage sags and swells are a common monitoring target when analyzing power quality. Any signal in the device can be used to trigger the disturbance recorder, including the protection functions for overvoltage, undervoltage, and programmable stages. With Arcteq's quickly operating protection functions, the device can record and document voltage sags and swells of as fast as 10...15 ms.

HARMONIC MONITORING

AQ 200 devices measure harmonics of up to the 31st order for both currents and voltages. Our innovative and unique harmonic overcurrent function (50H/51H/68H) can be used for alarming, tripping, and triggering the disturbance recorder. The function's stages can be set freely, and they can monitor and act on any current harmonic you want from the 2nd to the 19th order. Additionally, the disturbance recorder can record harmonic content up to the 31st order.

DISTURBANCE RECORDER SETTING EXAMPLES

Samples per cycle	64	64	64
Number of analog channels	8	8	8
Number of digital channels	24	24	24
Record duration	5 s	10 s	60 s
Total number of records	100	52	8

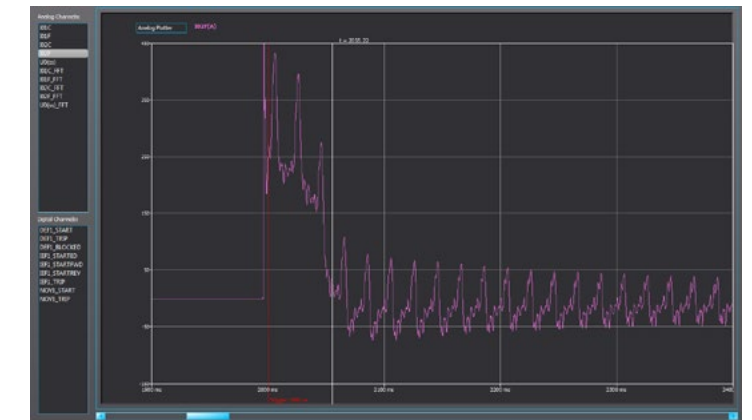

An example record with a high harmonic content.

The AQ 200 series disturbance recorder is a great tool for analyzing the performance of the power system in network disturbance situations.

Cable-end differential protection

CABLE-END FAULTS AND ARC FLASH INCIDENTS

Arc flash faults inside switchgear can be caused by a variety of reasons: human errors, equipment failures, aging materials, lack of maintenance, or by having anything from dirt to foreign objects or animals in the switchgear. Empiric data suggests that the most common fault location without human intrusion is the cable compartment. Cable-end faults are usually the result of degrading insulation levels or faulty cable connections, and these faults often start when a small ground leakage develops into a full single-phase fault. If it is not detected and tripped in time, the single-phase fault can develop further into a cross-country fault or a three-phase fault.

COMPENSATED CABLE-END DIFFERENTIAL PROTECTION

Arcteq has developed a proactive cable-end protection that aims to provide a way to detect a cable-end fault early. Traditionally, cable-end protection has been implemented via an alarming function that only indicates a need for preventative maintenance rather than detecting the fault itself. The operating principle of our cable-end protection is based on low-impedance differential protection function with settable bias characteristics. The differential current is calculated with the sum of the phase currents and the selected residual current input (measured by a core balance current transformer).

The cable-end differential protection function provides natural measurement unbalance compensation which allows our devices to have a higher operating sensitivity for monitoring cable-end faults. When calculating the residual current from the phase currents, a natural unbalance can be as high as 10 % in Class 5P current transformers. However, when this function's differential setting parameters are set to be sensitive, the natural unbalance current is compensated and does not affect the calculations.

If a cable-end starting fault occurs, the function detects the difference between the ingoing and outgoing residual currents. The resulting signal can then be used to alarm or trip the feeder with the failing cable end. Users can freely set the parameters of the function, and therefore decide how sensitive they want the algorithm to be.

NO ADDITIONAL HARDWARE OR WIRING NEEDED

The function uses the elements that are already available in the protection scheme, namely the three-phase CTs and the residual core balance CT. This means that there is no need for additional hardware or wiring. The sensitive compensated cable-end differential protection function can be used with no extra cost to provide more safety for both switchgear and personnel.

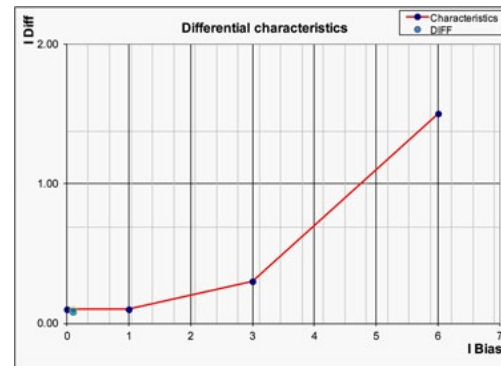
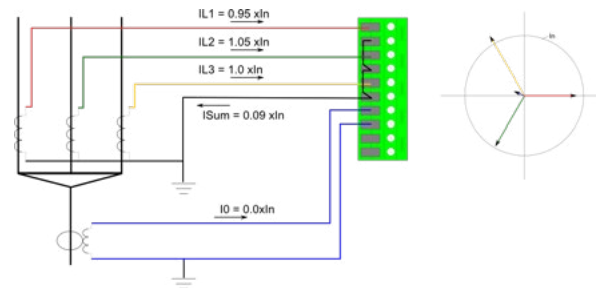

The images above show cable-end differential protection without natural unbalance compensation. The phase current CT errors cause a significant differential current. Compensation is essential to have a sensitive protection setting.

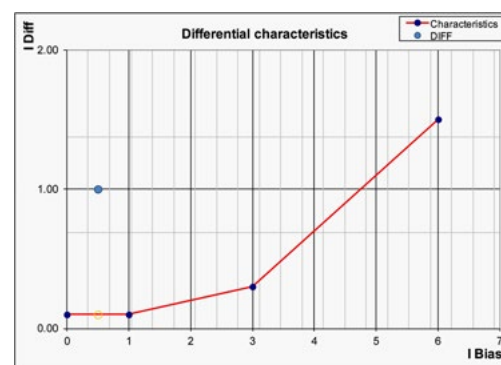
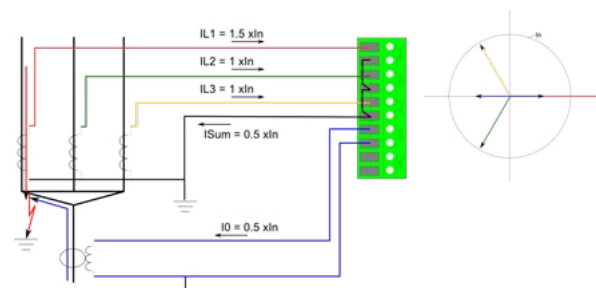

The images above show compensated cable-end differential protection during a small earth-leakage current. With the natural unbalance compensation, the function can alarm correctly even during small differential currents.

AQ-S254A - A new generation of alarm annunciators

BACKGROUND

Several markets use an alarm unit or an alarm annunciator as the standard device in substations. The annunciator's purpose is to collect alarm signal data from the entire substation into a single place, which makes it easy to handle an overview of all alarms. The annunciator unit is used in various substation applications: power plants and electrical utilities as well as industrial applications which require a collected monitoring of alarm signals.

The alarm annunciator AQ-S254A is a multipurpose device which extends the alarm functionality and the I/O capacity of a distribution or transmission substation. Its fully modular hardware construction gives you a high level of flexibility as functionality can be added or changed at any point as needed.

In addition to handling alarms, AQ-S254A comes equipped with a wide range of communication protocols. It also has a full-color, freely configurable mimic display to indicate switch statuses and other indicator changes. AQ-S24A is also capable of controlling up to 20 objects, such as circuit breakers and disconnectors.

ONE OF A KIND

To best meet the needs of demanding substation conditions, the AQ-S254A alarm annunciator has been designed and tested according to the IEC 60255 measuring relays and protection equipment standard. You can wire up to 115 binary signals to the annunciator. The 7 inch multicolor dynamic display allows you to see 128 alarms (including 64 GOOSE messages) at the same time. You can assign the various alarming states any of the 5 available colors, and add short descriptions (max. 31 characters) to each alarm. You can add up to 5 local HMI screens with mimic pictures to the device display.

AQ-S254A includes various communication protocols, including IEC 61850 communication with GOOSE messaging. You can connect to the device with an Ethernet or serial connection via its standard communication ports. You also have access to a redundant IEC 61850 protocol with HSR/PRP/RSTP. Other communication protocols include IEC 101/104, IEC 103, DNP3, Modbus, and SPA.

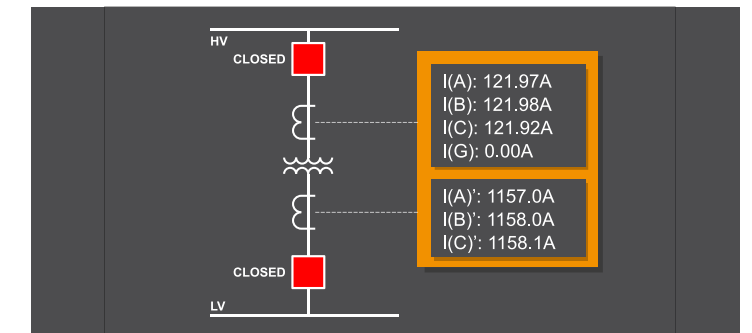

The graphical mimic editor helps you to create informative color displays for various indicators and objects.

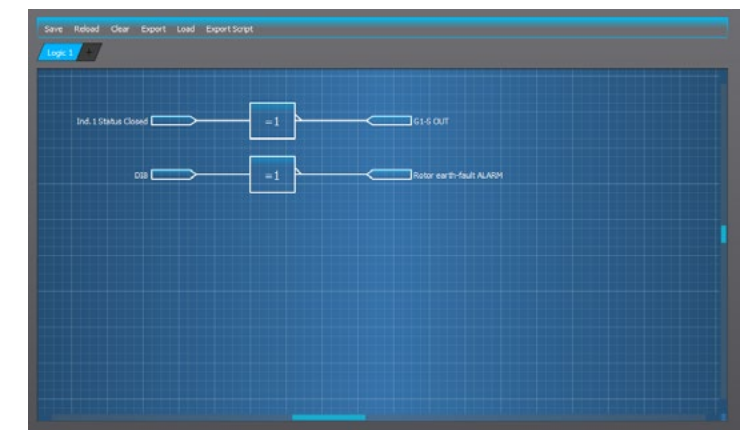

You can extend the functionality of an AQ-S254 device even further with the logic editor.

Gateway in arc protection schemes

If necessary, AQ-S254A can also be included in an AQ 100 series arc protection system, where it functions as the system's gateway. With the graphical mimic editor, you can add a local HMI display for the arc protection system. Another HMI display is dedicated for self-supervision, for light and current activation, as well as for trip alarms with events logs from every AQ 100 series device. With AQ-S254A as the system gateway, you can extend the communication on the substation level to RTU or directly to SCADA. AQ-S254A includes the IEC 101/104 protocols for the SCADA connection.

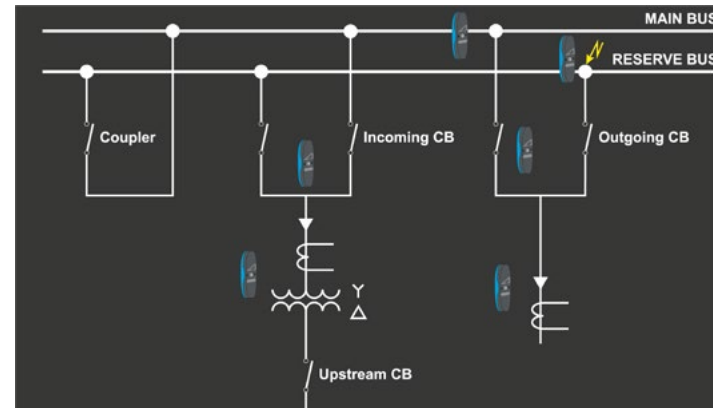

A single-line diagram indicating a faulty section in an AQ 100 arc protection system.

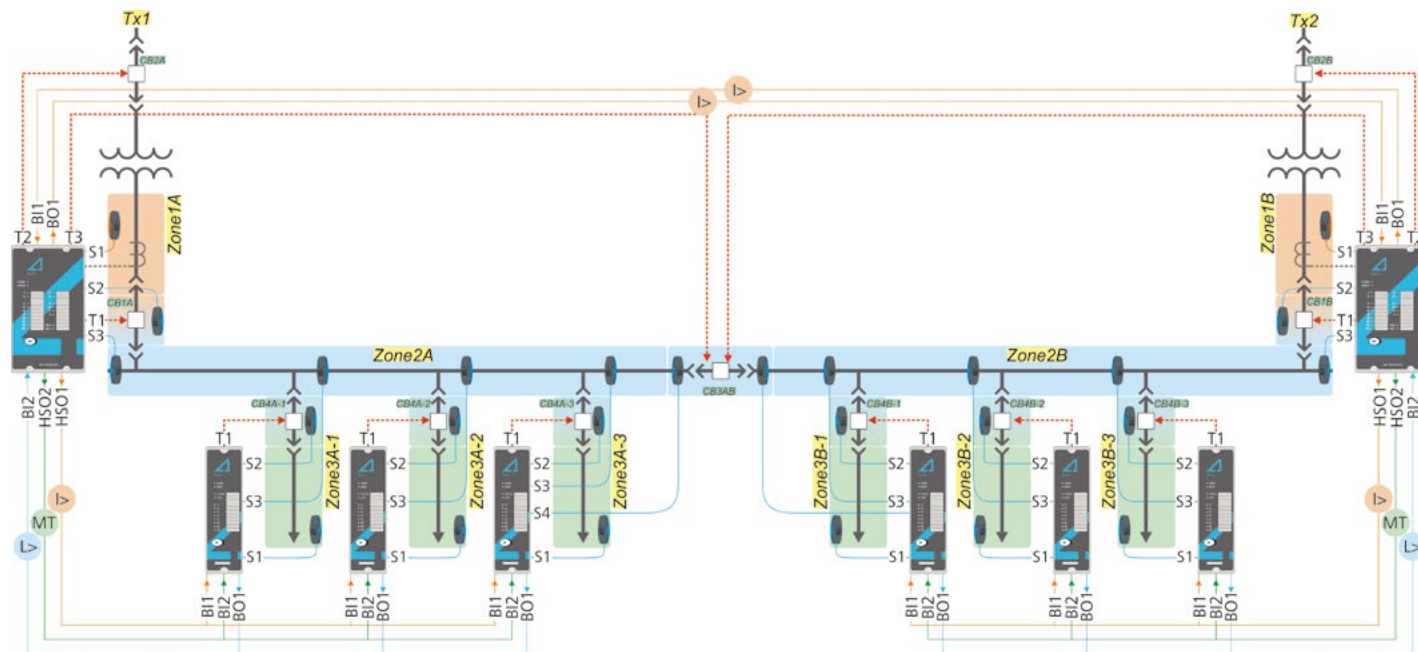

AQ-C255 The power factor controller

AQ-C255 device is the power factor controller (PFC) of an automatic capacitor bank system. It performs the switching of capacitors to reach a user-defined target $\cos\phi$. With the integration of a power factor controller, it is possible to optimize processes, speed up troubleshooting and reduce the costs of the supervised systems. The power factor controller permanently monitors the reactive power of the installation and controls the power factor. The control is done by connecting and disconnecting the power capacitor banks. When the power factor decreases, the controller activates the capacitors sequentially. The controller will continue to add capacitors in parallel to the load until a required value of the power factor is attained.

AQ-C255 has highly advanced algorithm that allows user to have from 1 to 5 capacitor banks with flexible VAR values, with the option of various control schemes i.e. First-in, First-out (FIFO), First-in, Lastout (FILO) and minimum step mode suitable for capacitor banks of same and different values. In addition to power factor correction, it is possible to indicate current, voltage, power, frequency, and other values. The AQ-C255 operates like the brain of the power correction system. The PFC function can operate while one or more capacitor banks are under maintenance and it comes with built-in resettable counter (for open & close) for each bank to monitor the performance.

BASIC OPERATION

- PFC is operated when adjustment of VAR is required - which is defined by $\cos\phi$ setpoint
- The operation is blocked when the discharge time is active, which can be programmed for each bank individually
- A programmable switching time is also possible, which ensures a defined time duration between connecting or removing capacitor banks consecutively

REAL TIME DISPLAY

- Maximum VAR available in the system (combined)
- Utilized VAR, available VAR, individual VAR values (each bank)
- Power factor, power factor direction, bank condition, counters..

CONTROL SCHEMES

- First-in, first-out (FIFO) - suitable for the capacitance of equal values, and ensures minimum optimal usage
- First-in, last-out (FILO) - suitable for the capacitance of equal values, and switches sequentially
- Minimum step - suitable for capacitance of different values and the algorithm is design to step up the minimum possible value of the capacitance



The AQ C255 Power Factor Controller

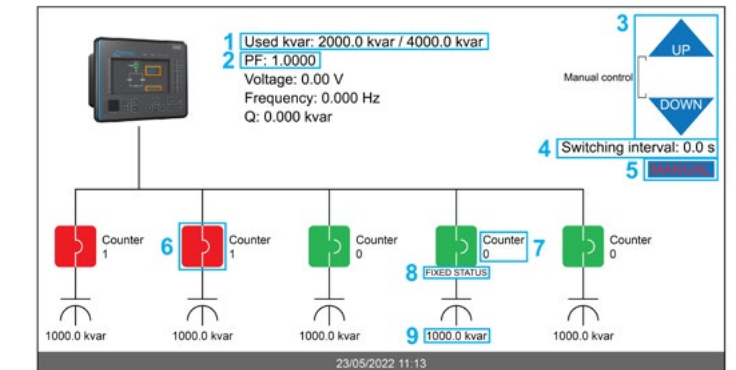

- 1.Total VAR value (used) and maximum available VAR (reserve)
- 2.Measured power factor
- 3.Increase/decrease power factor, in case of manual control (By using push buttons F1 and F2)
- 4.User-defined switching internal for consecutive opening/closing of the capacitor banks
- 5.Resettable counter (for open & close) for usage of each capacitor bank
- 6.Connection status of each capacitor bank
- 7.Maintenance status, which can be defined by inputs
- 8.Individual VAR for each capacitor bank
- 9.Automatic or Manual mode (The mode can be changed by push button F3 in the front panel)

Setting and configuration software

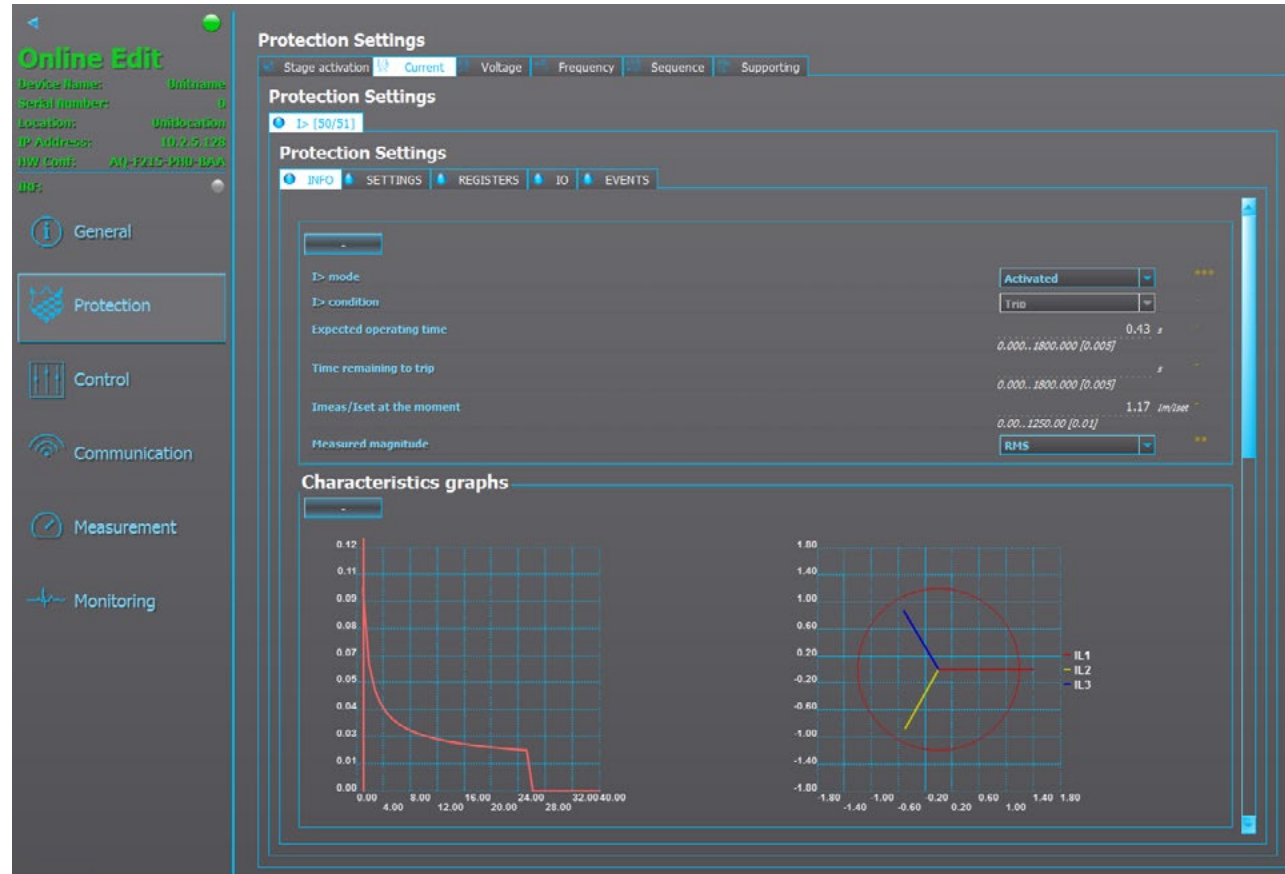

AQtivate 200 groups functionalities clearly and only shows activated functions, guaranteeing a familiar working experience while using the software.

All AQ 200 series devices can be configured and set conveniently with the help of our powerful AQtivate 200 software. AQtivate 200 is easy to use, and you can download and use it completely free. With this software you can set your protection functions, configure the I/O, program additional logic diagrams, configure the HMI display, set the parameters for communication protocols, and view the sophisticated online monitoring.

AQtivate 200 puts all device functionalities into clear groups: you can access protection functions, control functions, and monitoring functions from their own main menus. When you activate a function stage, all its settings and other information is accessible within its own tab in the relevant main menu. As only activated functions are displayed, the software provides you with a convenient setting and commissioning experience.

Integrated into the AQtivate 200 software are the several tools which make device configuration and function setting even better and easier. The graphical Mimic Editor tool helps you to easily build informative color displays for your device display, whereas the Logic Editor tool allows you to extend your device functionality further with common logic gates. You can configure the HMI display with the Carousel Designer tool.

Additionally, AQtivate 200 also includes three unique wizards for transformers, generators, and motors. They are advanced setting tools that use a selection of transformer and machine-related information and other settings as the basis for building suitable setting parameters for your device. Furthermore, their own manuals are integrated into the wizard tools themselves to make their use as easy as possible.

AQtivate 200 can be used offline or online via the RJ-45 Ethernet port

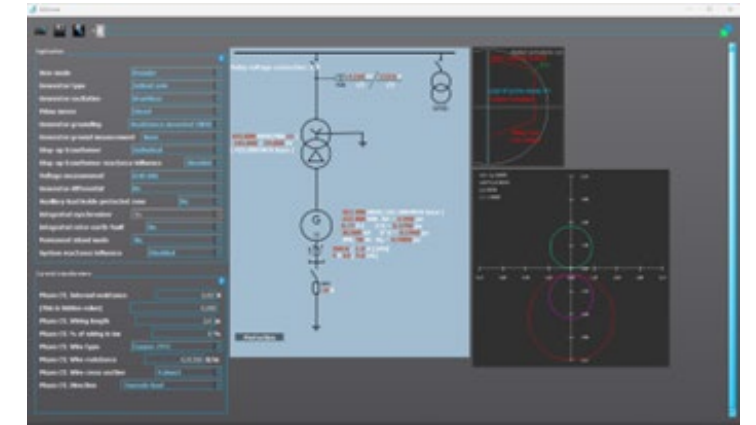

Generator wizard view.

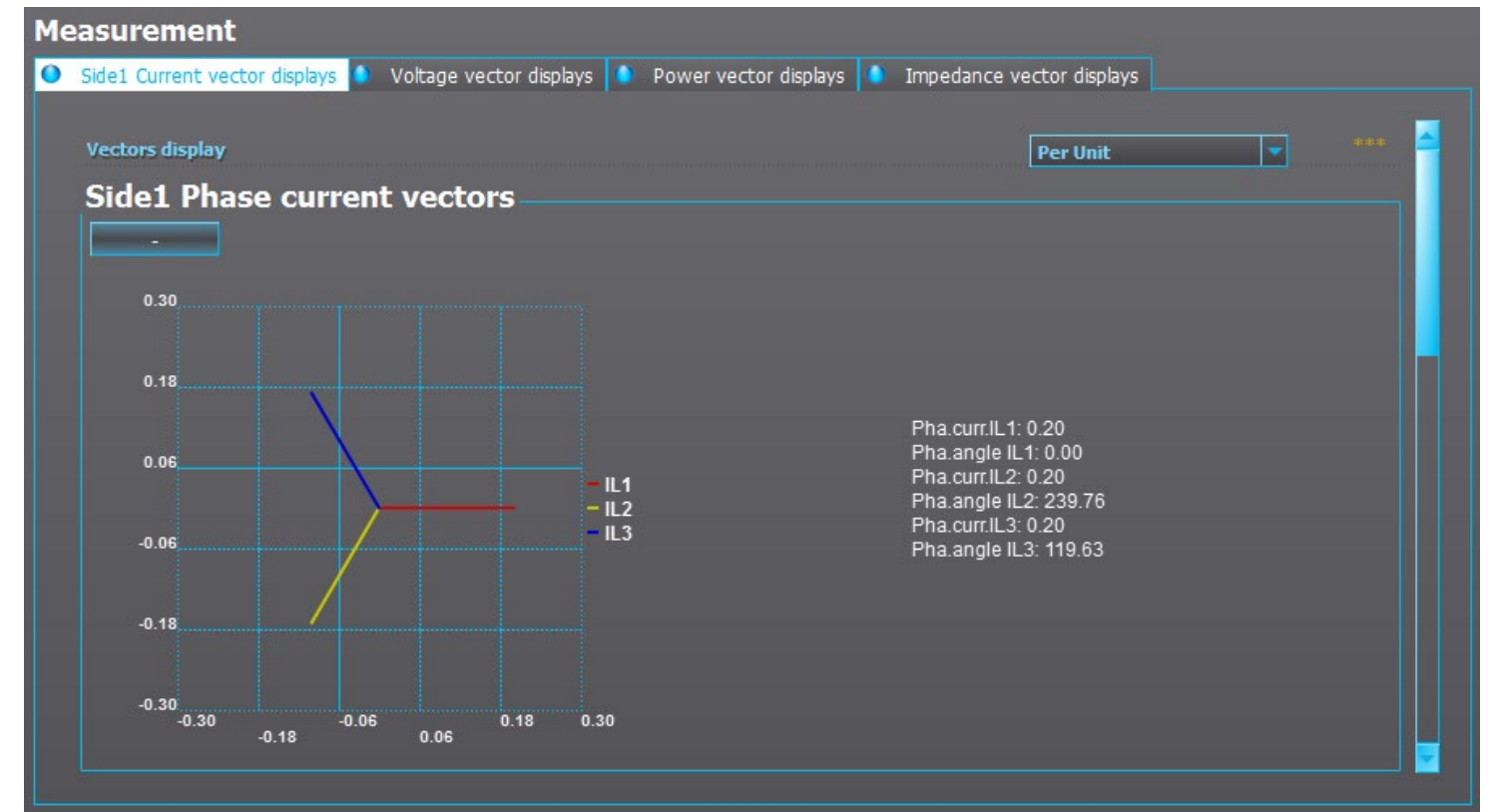

Online status displays save engineering time, from testing and commissioning to project commissioning.

The software also displays the online status of matrix signals. This saves you time during troubleshooting, project commissioning, and testing situations. AQtivate 200 comes with AQViewer, a separate software which provides you with a place for COMTRADE

disturbance recorder analysis. The Setting and configuration software AQtivate 200 configuration and setting software runs on recent Windows operating systems.

NON-DIRECTIONAL OVERCURRENT PROTECTION (50/51)

Used for instant, DT, and IDMT (IEC/ANSI/custom) overcurrent and short-circuit protection, the function has 1...4 stages (depending on the device model) and a wide setting range of 0.1...50 ×In. Its operation is based on the constantly measured phase currents (RMS, TRMS, or peak-to-peak values). The function includes an option for internal harmonic blocking (2nd and 5th).

NON-DIRECTIONAL GROUND FAULT PROTECTION (50N/51N)

Used for instant, DT, and IDMT (IEC/ANSI/custom) ground fault protection, the function has 1...4 stages (depending on the device model). Its operation is based on the constantly measured selected neutral currents (RMS, TRMS, or peak-to-peak values). The available analog measurement channels are the residual current measurements (I_{01} and I_{02}) as well as the residual current calculated from the phase current (IOCalc).

SINGLE-POLE NON-DIRECTIONAL OVERCURRENT PROTECTION (50/51)

Used for instant, DT, and IDMT (IEC/ANSI/custom) overcurrent and short-circuit protection, the function has 1...2 stages (depending on the device model) and a wide setting range of 0.1...50 ×In. Its operation is based on the constantly measured phase currents (RMS, TRMS, or peak-to-peak values). The function includes an option for internal harmonic blocking (2nd and 5th).

DIRECTIONAL OVERCURRENT PROTECTION (67)

Used for instant, DT, and IDMT (IEC/ANSI/custom) overcurrent and short-circuit protection, the function has 4 stages. Its operation is based on the constantly monitored phase currents (RMS, TRMS, or peak-to-peak). The function uses the direction of the calculated positive sequence voltage and setting parameters to determine the forward direction of the pick-up sector.

DIRECTIONAL GROUND FAULT PROTECTION (67N/32N)

Used for instant, DT, and IDMT (IEC/ANSI/custom) ground fault protection, the function has 4 stages. Its operation is based on the constantly measured selected neutral currents and voltages (RMS, TRMS, or peak-to-peak), and the selected earthing type. The magnitudes come from the residual current measurement (I_{01} or I_{02}), or from the residual current calculated from the phase current measurements (IOCalc). The current angle is compared to the angle of the measured/calculated zero sequence voltage. Tripping requires a set minimum amount of zero sequence voltage.

INTERMITTENT GROUND FAULT PROTECTION (67NT)

Used for intermittent transient ground faults protection, the function has 1 stage. Its operation is based on our patented measurement and sampling technology to detect transient spikes in IO and V_0 : it determines the spikes' polarity by calculating the delta of raw samples and is thus able to tell a faulty feeder from a healthy one. Users can set the function's operating time freely to guarantee co-ordination with back-up residual voltage protection. These faults usually happen in compensated (Petersen coil earthed) MV networks, which are becoming more and more common in the world.

NEGATIVE SEQUENCE OVERCURRENT PROTECTION, PHASE CURRENT REVERSAL PROTECTION, CURRENT UNBALANCE PROTECTION (46/46R/46L)

Used for instant, DT, and IDMT (IEC/ANSI/custom) unbalanced network protection and for detecting broken conductors, the function has 1...4 stages (depending on the device model). Its operation is based on the constantly measured negative and positive sequence currents. The function has two operating modes: the I2 mode monitors the negative sequence current, while the I2/I1 mode (the broken conductor mode) monitors the minimum loading current in the phase currents. Additional calculations and records are done (symmetrical component magnitudes, zero sequence current).

HARMONIC OVERCURRENT PROTECTION (50H/51G/68H)

Used for instant, DT, and IDMT (IEC/ANSI/custom) non-directional overcurrent detection and clearing, the function has 1...4 stages (depending on the device model). Its operation is based on the constantly measured harmonic components (absolute or relative to RMS) of the selected measurement channels (2nd, 3rd, 4th, 5th, 6th, 7th, 11th, 13th, 15th, 17th, or 19th harmonic).

CIRCUIT BREAKER FAILURE PROTECTION (50BF/52BF)

Used for monitoring the circuit breaker's operation after it has received a tripping signal, the function has 1 stage. The function can also be used to re-trip a failing breaker: if the tripping fails, an incomer breaker can be tripped with the function's CBFP output. The re-tripping functionality can be disabled if the breaker only has one trip coil. Users can set the operating times as required.

LOW- OR HIGH-IMPEDANCE RESTRICTED GROUND FAULT PROTECTION, CABLE-END DIFFERENTIAL PROTECTION (87N)

Used for residual differential current measurement for transformers or for cable-end differential protection, this function has 1 stage. Its operation is based on the constantly monitored phase currents and selected residual currents as well as the calculated bias current and differential currents. A differential current is calculated with the sum of the phase currents and the selected residual current input. In the cable-end differential mode the function provides natural measurement unbalance compensation for a higher operating sensitivity when monitoring cable-end faults.

OVERVOLTAGE PROTECTION (59)

Used for instant, DT, and IDMT (IEC/ANSI/custom) overvoltage protection, the function has 4 stages. Its operation is based on constantly measured phase voltages as well as line-to-neutral or line-to-line magnitudes (RMS). When the protection is based on a line-to-line voltage, it is not affected by ground faults in isolated or compensated networks.

UNDERVOLTAGE PROTECTION (27)

Used for instant, DT, and IDMT (IEC/ANSI/custom) undervoltage protection, the function has 4 stages. Its operation is based on the constantly measured phase voltages as well as line-to-neutral or line-to-line voltages (RMS). When the protection is based on a line-to-line voltage, it is not affected by ground faults in isolated or compensated networks. The function has two blocking stages: internal blocking (voltage measurement and low voltage) and external blocking (e.g., VT fuse failure).

NEUTRAL OVERVOLTAGE PROTECTION (59N)

Used for instant, DT, and IDMT (IEC/ANSI/custom) non-directional ground fault protection, the function has 4 stages. Its operation is based on the constantly measured phase-to-ground voltages, the calculated zero sequence components, or a dedicated voltage input. Protection is scaled to the line-to-line RMS level. With a line-to-line system voltage of 100 V (secondary), the ground fault is 100% of Un and the calculated zero sequence voltage is 57.74 V.

SEQUENCE VOLTAGE PROTECTION (47/27P/59PN)

Used for instant, DT, and IDMT (IEC/ANSI/custom) voltage protection, the function has 4 stages and has positive/negative sequence protection for both overvoltage and undervoltage as selected. Its operation is based on the system's line-to-line voltage level. The function constantly measures phase-to-ground voltages (RMS) and calculates positive/negative sequence voltages from the line-to-line and neutral voltages.

OVERFREQUENCY AND UNDERFREQUENCY PROTECTION (810/81U)

Used for instant and DT (IEC/ANSI/custom) overfrequency and underfrequency protection, the function has 8 stages (four for each). The function can be applied to feeder, bus, transformer, motor, and generator application protections. The difference between the generated power and the load demand can cause the frequency to drop/rise beyond the set limits, which is especially important to detect in generator applications. The function can also be used to indicate accidental island operation, and to control power generation to keep the system frequency consistent.

RATE-OF-CHANGE OF FREQUENCY (81R)

Used for instant, DT, and IDMT (IEC/ANSI/custom) detection of fast drops or increases in frequency, the function has 8 stages (four stages for both increase and decrease in frequency). It detects and clears frequency-based faults faster than conventional over- and underfrequency protections. An unbalance between generated power and load demand is the most common cause of frequency deviations, and if the unbalance is great enough the frequency changes rapidly. The function can also be applied to detect a loss of mains situation (a part of the network loses its connection to the rest of the system), where a connected generator can cause safety hazard and automatic reconnections can cause damage to both the generator and the network.

OVERPOWER, UNDERPOWER AND REVERSE POWER PROTECTION (320/32U/32R)

Used for instant, DT, and IDMT (IEC/ANSI/custom) active power protection, each of the functions has 1 stage. The overpower function detects overload situations in various types of applications; the underpower function detects loss of load when there is no significant loss of current; the reverse power function is used to protect the generator's turbine in situations where a synchronous generator runs like a motor, drawing active power.

POWER PROTECTION (32)

Used for instant and DT (IEC/ANSI/custom) three-phase overpower or underpower protection (active, reactive, or apparent), the function has 4 stages. It constantly calculates the ration between the power settings and the measured power magnitudes.

CAPACITOR BANK OVERLOAD PROTECTION (490L)

Used for instant, DT, and IDMT (IEC/ANSI/custom) overload alarming and capacitor bank protection, the function has 1 or 2 stages (depending on the device model). Its operation is based on the constantly measured phase currents (RMS, TRMS, and peak-to-peak). The main difference separating this function from the regular overcurrent function ($I > 50/51$) is that users can freely program the capacitor overload curve to the function by giving the current, the time points, or the IDMT coefficients.

CAPACITOR BANK NEUTRAL UNBALANCE PROTECTION (50UB)

Used for instant and DT (IEC/ANSI/custom) capacitor bank neutral unbalance protection, the function has 1 stage. Its operation is activated by a settable definite time delay which is counted from the moment when the alarm or trip threshold is exceeded. The basic design of the protection function is the three-pole operation.

CAPACITOR BANK CURRENT UNBALANCE PROTECTION (46C)

Used for instant and DT (IEC/ANSI/custom) capacitor bank current unbalance protection when the bank has a double wye configuration, the function has 1 stage. Its operation is based on the constantly measured phase currents (RMS).

RAILWAY NON-DIRECTIONAL OVERCURRENT PROTECTION (50/51)

Used for instant, DT, and IDMT (IEC/ANSI/custom) overcurrent and short-circuit protection, the function has 4 stages and a wide setting range

of $0.1...50 \times I_n$. Its operation is based on the constantly measured phase currents (RMS, TRMS, or peak-to-peak values).

RAILWAY DIRECTIONAL OVERCURRENT PROTECTION (67)

Used for instant, DT, and IDMT (IEC/ANSI/custom) directional overcurrent and short-circuit protection, the function has 8 stages (when a device has both voltage and current measurement modules). Its operation is based on the constantly measured phase currents (RMS). As a function in the railway protection module, the function can handle current and voltage measurements in railway frequencies (16.67 Hz) and the standard three-phase system frequencies (50 Hz or 60 Hz).

RAILWAY VOLTAGE PROTECTION (27/59)

Used for instant, DT, and IDMT (IEC/ANSI/custom) voltage protection, the function has 4 stages. Its operation is based on the constantly measured RMS values from the selected voltage channel. Users can select whether the function protects against undervoltage or overvoltage. As a function in the railway protection module, the function can handle current and voltage measurements in railway frequencies (16.67 Hz) and the standard three-phase system frequencies (50 Hz or 60 Hz).

MOTOR STATUS MONITORING (MST)

Designed as a single place where users can set up all necessary motor data and select the motor protection functions relevant to their application. The function parameters can also be set within each function; all changes in the individual functions are updated to this compilation function as well. In addition to motor data, the motor status monitoring function also counts how many times the motor has started, how many times the start has succeeded, and how many times the motor has stopped. It also tracks the motor's running time and starting time as well as when the motor last stopped.

MOTOR START PROTECTION, LOCKED ROTOR MONITORING (48/14)

Used for monitoring the start-up duration and the stress it causes to the motor. The function has 1 stage, and it can also be used as locked rotor protection after starting. The function has two operating modes:

definite maximum locked rotor time monitoring and inverse operating time (based on the I^2t calculation). When using the latter, the maximum allowed starting time is automatically scaled to the motor's current to compensate for the starting conditions. Users can also set the speed switch input. The function operates with the motor status monitoring function, following the data set there.

FREQUENT START PROTECTION (66)

Used for monitoring and preventing the motor from starting too frequently, the function has 1 stage. It monitors how many times the motor has started within a given time frame to ensure that the start stress does not exceed the manufacturer's limits, allowing the motor to cool down sufficiently before the next start attempt. The function operates with the motor status monitoring function, following the data set there.

NON-DIRECTIONAL UNDERCURRENT PROTECTION (37)

Used for instant and DT (IEC/ANSI/custom) undercurrent protection, the function has 1 stage. Its operation is based on the constantly measured phase currents (RMS). The function monitors motor loading: a sudden loss in the load can indicate problems with the actual load (a broken belt, other mechanical problems) and the motor needs to be turned off immediately to avoid further damage. In automation systems the function can be used to indicate a finished task. The function operates with the motor status monitoring function, following the data set there. Its operation is blocked when the motor is not running.

MECHANICAL JAM PROTECTION (51M)

Used for instant and DT (IEC/ANSI/custom) monitoring of the motor loading after the motor has started, the function has 1 stage. Its operation is based on the constantly measured phase currents (RMS). When a motor-run apparatus jams during its work load, the function can be used to disconnect the motor from the feeding network to avoid further damage. The function operates with the motor status monitoring function, following the data set there. Its operation is blocked during motor starting.

POWER FACTOR PROTECTION (55)

Used for instant and DT (IEC/ANSI/custom) power factor protection, the function has 1 stage. Its operation is based on the calculated three-phase power factor ($\cos \varphi$). The function cannot detect a power factor that is less than 0.05.

MACHINE THERMAL OVERLOAD PROTECTION (49M)

Used for thermal capacity monitoring and protection of electric machines, the function has 1 stage. It constantly monitors the instant values of phase currents (RMS) and calculates the set thermal replica status in 5-ms cycles; it also includes a total memory function of the load current conditions according to IEC 60255-8. The function's highly-accurate motor and generator thermal modeling is based on up to five different time constants, and it sets up a thermal replica to calculate and display the protected object's thermal loading in relation to the object's effective current. The function is differentiated from regular overcurrent function by the calculated thermal capacity in the replica. The function operates with the motor status monitoring function, following the data set there.

UNDEREXCITATION PROTECTION (40)

Used for instant and DT (IEC/ANSI/custom) underexcitation protection, the function has 1 stage. Its operation is based on constantly calculated three-phase reactive power values. Synchronous machines require a set amount of excitation to stay stable: when a generator induces capacitive power, the reactive power becomes negative, which in turn makes the excitation current too low, resulting in the machine dropping out of step. The function supervises the capacitive power and picks up when the set kvar value is exceeded.

UNDERIMPEDANCE PROTECTION (21U)

Used as an instant and DT (IEC/ANSI/custom) alternative for voltage-restrained overcurrent protection, the function has 2 stages. Its operation is based on constantly calculated primary impedances (phase-to-phase, phase-to-earth, positive sequence). The function can be used to detect even small short-circuit faults near the generator. Additionally, it can be used as back-up protection for transformer protection.

UNDERREACTANCE PROTECTION (21/40)

Used for instant and DT (IEC/ANSI/custom) underreactance protection, the function has 2 stages. Its operation is based on constantly calculated primary impedances (phase-to-phase, phase-to-earth, positive sequence). The function monitors the distance between the defined circle and the measured impedance.

100% STATOR GROUND FAULT PROTECTION (64S)

Used for instant, DT, and IDMT (IEC/ANSI/custom) detecting ground faults near the neutral point, the function has 1 stage. Its operation is based on constantly measured phase currents (RMS) and the constantly measured 3rd harmonic neutral voltage of the selected voltage channel. Even in the best case scenario, at least 5% of the stator remains outside the conventional neutral overvoltage protection function's range: this function complements the other to protect the whole stator.

VOLTAGE-RESTRAINED OVERCURRENT PROTECTION (51V)

Used for instant, DT, and IDMT (IEC/ANSI/custom) voltage-restrained overcurrent protection, the function has 1 stage. Its operation is based on the constantly measured phase currents and voltage channel values (RMS). Because short-circuits that occur close to the generator inhibit the operation of high-set overcurrent stages, this function is used to improve sensitivity. Depending on the parameter settings, the function can act as voltage-restrained or voltage-controlled overcurrent protection. Additionally, the function can be used as an alternative for the underimpedance protection function for more sensitive short-circuit detection in generator applications.

VOLTS-PER-HERTZ OVEREXCITATION PROTECTION (24)

Used for instant and DT (IEC/ANSI/custom) overexcitation protection, the function has 1 stage. Its operation is based on the constantly measured phase-to-phase voltages (RMS). Machine manufacturers specify the specific V/Hz ratios under which they are not expected to operate. Exceeding these limits results in machines overexcitation which causes excessive voltage and current heating to damage the machine's insulation (within seconds in generators). The most common situation for overexcitation takes place when a machine is offline before synchronization.

POLE SLIP PROTECTION (78)

Used for protecting machines and transformers against pole slipping within a set slip detection area, the function has 1 stage. Its operation is based on the constantly measured phase currents (RMS) as well as on the impedance calculated from phase-to-phase or phase-to-neutral voltages (RMS). Pole slip refers to the phenomenon where synchronism is lost due to power swings. Especially for generators this causes stress and possible damage to the machine.

LINE THERMAL OVERLOAD PROTECTION (49F)

Used for thermal capacity monitoring and protection of cables and overhead lines, the function has 1 stage. It constantly monitors the instant values of phase currents (RMS) and calculates the set thermal replica status in 5-ms cycles; it also includes a total memory function of the load current conditions according to IEC 60255-8. The function's thermal modeling sets up a thermal replica to calculate and display the protected object's thermal loading in relation to the current going through the object. The function is differentiated from regular overcurrent function by the calculated thermal capacity in the replica.

TRANSFORMER STATUS MONITORING (TRF)

Designed as a single place where users can set up all necessary transformer data and select the transformer protection functions relevant to their application. The function parameters can also be set within each function; all changes in the individual functions are updated to this compilation function as well. The function calculates many transformer-related properties used to monitor and protect the transformer. In addition to name plate data, the transformer status monitoring function also counts how many times the transformer has overloaded (cumulative) and keeps track of its high overcurrent time. While standard transformers only require name plate data and CT scalings, you can manually set additional parameters to meet rarer transformer parameters encountered in special transformers.

TRANSFORMER THERMAL OVERLOAD PROTECTION (49T)

Used for monitoring and protecting the thermal capacity in power transformers, the function has 1 stage. It constantly monitors the instant values of phase currents (TRMS) and calculates the set thermal replica status in 5-ms cycles; it also includes a total memory function of the load current conditions according to IEC 60255-8. The function's thermal modeling sets up a thermal replica to calculate and display the protected object's thermal loading in relation to the current going through the object. The function is differentiated from regular overcurrent function by the calculated thermal capacity in the replica. The function operates with the transformer status monitoring function, following the data set there.

TRANSFORMER/MOTOR/GENERATOR DIFFERENTIAL PROTECTION (87T/87M/87G)

Used for the differential protection of generators and certain transformers, the function has 1 stage. The function can be used to protect the following power transformers: two-winding transformers, and to some extent three-winding and two-winding transformers that have double outputs and a summing application. Its operation is based on the constantly calculated phase currents (phase bias currents, phase differential currents, maximum differential currents allowed by the set current bias level) and HV/LV side currents (REF bias currents, REF differential currents, maximum REF differential currents allowed by the set current bias level).

RESISTANCE TEMPERATURE DETECTORS (RTD)

Used for measuring both ambient temperatures and machine temperatures ($^{\circ}\text{C}$ or $^{\circ}\text{F}$), the function has 12 stages. Its operation is usually based on a thermocouple or a PT100-type RTD. The function supports up to 3 separate RTD modules, each of which can hold up to 8 measurement elements. You can set max. 16 individual element monitors for this alarm function; each can be set to give 2 separate alarms from one selected input.

ARC FAULT PROTECTION (50ARC/50NARC)

Used for protecting against arc faults, the function has 1 stage. Arc faults can occur for many reasons (such as insulation failure, foreign objects in switchgear, mechanical aging), and their fast detection is necessary to minimize their effects. However, detecting arc faults from measured currents and voltages is slower than detection by arc sensors as in the arc protection module and this function. The module includes high-speed outputs to extend the speed of arc protection by tripping signals faster.

PROGRAMMABLE STAGE (99)

Used for programming more advanced custom applications, the function has 10 instant or DT (IEC/ANSI/custom) stages. Each stage can be set either as an individual stage or together with programmable logic. A stage can be set to follow 1...3 analog measurements, and it has 3 pick-up term options: greater than, lesser than, and rate-of-change of the selected signal.

VOLTAGE MEMORY (V. MEM.)

Used for helping calculate fault directions and/or distances in situations where the system fault is absent (such as close-in faults) and using non-directional protection for tripping would reduce the network selectivity. The function's operation is based on an adjustable voltage level with pre-fault voltage angles. Certain protection functions (such as directional overcurrent) use the measured current and voltage values to determine whether a fault occurs within a protected area by comparing the angle between the operating and the measured quantities, and for them this backup function is important. The duration reference can also be set manually, and you can even initiate time-delayed back-up tripping with the voltage memory function.

SETTING GROUP SELECTION (SGS)

Used for controlling the availability and selection of setting groups, of which all AQ 200 series devices have 8. By default, only one setting group ("SG1") is active, and the selection logic is idle. When you have enabled one or more additional setting groups, the selection logic activates the groups based on the logic and conditions you have programmed. You can also switch between the enabled setting groups with any digital signal (including GOOSE messages) or force a change with local controls (AQtivate 200 setting tool, HMI, or SCADA).

OBJECT CONTROL AND MONITORING (OBJ),

Used to control objects, including circuit breakers and disconnectors. The exact number of objects depends on the device model and available inputs (1 object, 1...5, or 1...10 objects). The function's operation is based on the statuses of the configured digital inputs and outputs. Usually, object control requires at least two output contacts, while object monitoring requires at least 2 digital inputs. However, if required monitoring can be done with a single digital input (switch the input's active and zero states in the device's Logic editor).

SINGLE-POLE OBJECT CONTROL AND MONITORING (OBJ5)

Used to control and monitor single-pole objects, including circuit breakers and disconnectors. The function can control and monitor 1 single-pole object. The function's operation is based on the status of the configured object. The control of single-pole objects requires at least 4 output contacts, while its monitoring usually requires 6 digital inputs. The function has 3 operating modes: it can open all breakers, open each phase individually, or open all phases.

INDICATOR OBJECT MONITORING (IND)

Used to monitor the status of disconnectors, the function has 1 stage. Its operation is based on the statuses of the configured digital inputs, and it has no control functionality. The exact number of indicator objects depends on the device model and the available inputs (1...5, 1...10, or 1...20 indicator objects). Usually, indicator object monitoring requires two digital inputs, although monitoring can be done with a single digital input (switch the input's active and zero states in the device's Logic editor).

COLD LOAD PICK-UP (CLPU)

Used for detecting cold-load situations (a loss of load after distribution re-energizing) and blocking protection functions based on these cold loads, the function has 1 stage. The characteristics of various cold-load situations depend on the load types that individual feeders have, which means that this function has to be set specifically according to the monitored load type (e.g., high inrush current from the many thermostat-controlled devices in residential areas vs. industrial start-up processes that can take days).

SWITCH-ON-TO-FAULT (SOTF)

Used to speed up tripping and reducing damage in the fault location when the breaker is closed towards a fault or a forgotten earthing. It has 1 stage, and it can be used to control protection functions or to initiate direct tripping. The function's typical operating time is less than 20 ms, and the operation is based entirely on digital signal statuses.

SYNCHROCHECK (25)

Used to ensure that two systems are synchronized before closing the circuit breaker between them, the function has 3 stages. Its operation is based on the constantly measured voltages (RMS), and the function also monitors the frequency and the angle of the selected voltage channel. The availability and function of the stages depends on which voltage channels have been set to SS mode; at least one voltage channel (U3 or U4) must be active to access the function. The function supervises the synchronization condition between a specific voltage channel and the selected system voltage, or between two voltage channels.

VECTOR JUMP (78)

Used for detecting most islanding situations (that is, when power is supplied to a load only from distributed generators) and switching off the mains breaker, the function is used for instant tripping and has only 1 stage. This lets the generator only supply loads according to their rated power value, meaning that an overload does not cause any mechanical stress to the generator unit(s). The function's operation is based on the samples of the selected measured voltages (64 samples per cycle). The reference voltage can be all or any phase-to-phase or phase-to-neutral voltages. The vector jump device should be located either on the mains side of the operated breaker or on the islanding generator's side.

SYNCHRONIZER (25)

Used to synchronize generators to power grids automatically, the function has 1 stage. Its operation is based on the constantly measured voltages from selected voltage channels (RMS). Proper synchronizing is essential to avoid inrush currents, power system oscillations as well as thermal and mechanical stress on the generator. The function controls the amplitude,

the speed, and the phase-angle between the two voltages to allow a close command signal to the generator's circuit breaker. You can synchronize max. 8 circuit breakers with this one function by using different setting groups and the Logic editor.

AUTOMATIC VOLTAGE REGULATOR (90)

Used for controlling a transformer's tap changer within a set voltage window, the function has 1 stage. Internal overcurrent blocking and low-voltage blocking prevent the tap from burning during overcurrent faults and move the tap to its high position when the bus is de-energized. When a high overvoltage occurs, the function controls the tap to its low position as fast as mechanically possible to reduce the voltage to a minimum. The function has 2 modes: independent and parallel. The independent mode allows you to control one transformer's tap changer with both high- and low-speed schemes, and its operation is based on the constantly measured phase-to-phase voltages and phase currents (RMS). The parallel mode allows you to control up to 4 transformer tap changers in parallel with a plug-and-play GOOSE configuration, and its operation is based on the constantly measured circulating current as well as the calculated circulating current deviation, voltage deviation, and total deviation. Additionally, the parallel control method can be selected between the master-follower mode and the circulating reactive current mode.

AUTO-RECLOSER (79)

Used for opening the circuit breaker of a line with a transient or semi-permanent fault to de-energize it and its fault location so as to give the cause of the fault a possibility to drop from the line and clear the fault. After a set time the breaker is automatically closed, and the line is re-energized. If the fault is not cleared by the first cycle of de-energizing and re-energizing ("a shot"), up to 4 additional shots are applied to the

line. The shots can be independent or scheme-controlled; schemes are especially useful for evolving faults. Approximately 80...95 % faults in transmission and distribution networks are faults that can be cleared with high-speed auto-reclosing, while the remaining faults can be cleared with delayed auto-reclosing by de-energizing the faulty line for a longer period of time. However, the function cannot clear permanent faults or cable network faults in mixed networks. You also need to be aware of the fault location before applying auto-reclosing as the function would only cause unnecessary stress to the lines and circuit breakers during faults that the function cannot clear.

ZERO SEQUENCE RECLOSER (79N)

Used when the ground fault current is so low that the directional ground fault protection cannot detect the fault's direction, the function has 1 stage. Together with the neutral overvoltage protection function, this function works as a back-up for finding an outgoing feeder with a fault, while at the same time disconnecting as few healthy feeders as possible (and reconnecting the disconnected healthy feeders as quickly as possible). Feeder breakers are set up to be opened and closed one after another in small time increments until the faulty feeder is disconnected. No communication between feeder devices is required.

POWER FACTOR CONTROLLER (90PF)

Designed as the control unit of an automatic capacitor bank system, the function has 4 stages. Its operation is based on three constantly measured phase-to-phase voltages, or phase-to-neutral voltages with the three phase currents. The function performs the switching of capacitors to reach a user-defined target $\cos \varphi$ by constantly monitoring the installation's reactive power and by connecting and disconnecting capacitor banks sequentially in parallel to the load to attain the set power factor. This

function allows the device to use power efficiently: a standard power supply has a factor of 0.70...0.75, whereas this function allows the power supply to have a factor of 0.95...0.99.

EXCITATION CONTROL

The exciter unit provides synchronous machine control, and it can be used by any machine with an apparent power of max. 250 MVA. The unit includes 4 excitation control modes: the automatic voltage regulator (AVR), the field current regulator (FCR), the reactive power controller (MVAR), and the power factor controller (PF). There are also 5 excitation limiters: the underexcitation limiter (UEL), the stator current limiter (SCL), the field current limiter (IFCL and DFCL for instant and time-delayed operation), and the V/Hz limiter (VHZ). In addition, the unit includes the power system stabilizer (PSS) and voltage supervision (SUP).

CURRENT TRANSFORMER SUPERVISION (CTS)

Used for instant and DT (IEC/ANSI/custom) monitoring current transformers as well as the wirings between the AQ 200 series device and the CT inputs for malfunctions and wire breaks, the function has 1...2 stages (depends on the device model). Its operation is based on the constantly measured phase currents and residual currents (RMS). The function also supervises the angles of each current measurement channel, and calculates the positive and negative sequence currents. An open CT circuit can generate dangerously high voltages into the CT secondary side and thus cause unintended activations of current balance monitoring functions.

VOLTAGE TRANSFORMER SUPERVISION (VTS; 60)

Used for instant and DT (IEC/ANSI/custom) detection of errors in the voltage transformer's secondary circuit wiring and during fuse failures, the

function has 1 stage. Its operation is based on the constantly measured voltage channel values and on the constantly calculated positive, negative, and zero sequence voltages. The function also monitors the angle of each voltage channel. When a device has both current and voltage measurements, the magnitudes are cross-compared to separate a VT failure from a fault. However, the function is often used as an alarming function or to disable functions that require a specific minimum amount of voltage measurement.

CIRCUIT BREAKER WEAR MONITORING (CBW)

Used for monitoring a circuit breaker's lifetime and maintenance needs due to interrupting currents and mechanical wearing, the function has 1 stage. It uses the data supplied by the CB manufacturer to monitor its operating cycles in relation to the interrupted current magnitudes. Its operation is based on the constantly measured phase currents (RMS). The function is integrated into the object control and monitoring function which is why it can be enabled and set there. However, it is also an independent function and initializes as an independent instance with its own events and settings not related to the object it is linked to.

CURRENT TOTAL HARMONIC DISTORTION (THD)

Used for constantly monitoring the content of the current harmonic, the function has 1 stage. Its operation is based on the constantly measured phase and residual currents: it uses the FFT measurement of the whole harmonic spectrum up to the 31st harmonic component from each current channel, and calculates either the amplitude ratio or the power ratio. When the function is activated, these measurements become available for mimic displays and are shown in the measurement view in the HMI.

Harmonics can be caused by various sources in electrical networks, and you can use the function to alarm when the harmonic content rises too high. Additionally, you can create alarm limits for each measured channel individually if the application so requires.

FAULT LOCATOR (21FL)

Used for recording an estimated distance to the point where a fault has occurred, the function has 1 stage. Its operation is based on the constantly calculated phase-to-phase or phase-to-ground loop impedances from the current and voltage measurements (RMS). The function is mostly used in directional overcurrent protection or distance protection applications, but it can also be triggered by other protections. Using the function requires that all three phase currents and all three phase voltages have been connected to the device.

DISTURBANCE RECORDER (DR)

Designed as a high-capacity and fully digital recorder, the function is integrated into all AQ 200 series devices. It has a 64-MB permanent flash memory, its maximum sample rate for its analog channels is 64 samples per cycle, and its maximum capacity is 100 recorders. The recorder provides a great tool for analyzing the performance of the power system during network disturbance situations. As the recorder outputs records as general COMTRADE files, you can use most viewers and injection devices to playback captured recordings to help you analyze the fault. The files are based on the IEEE standard C37.111-1999.



AQ 210 and AQ 250 series protection and control devices

On the following pages you will find detailed information about all the protection and control devices in the AQ 210 and AQ 250 series. From the point of view of protection performance, the series are largely identical. The difference between the two series is in the display and the expandability of the device. The AQ 210 series devices have a monochrome display and up to 6 expansion slots, whereas the AQ 250 series devices have a full-color display and up to 14 expansion slots.

- You can find all AQ 210 series devices on pages 26—42.
- You can find all AQ 250 series devices on pages 43—57.
- You can find descriptions for all available option modules on page 62.

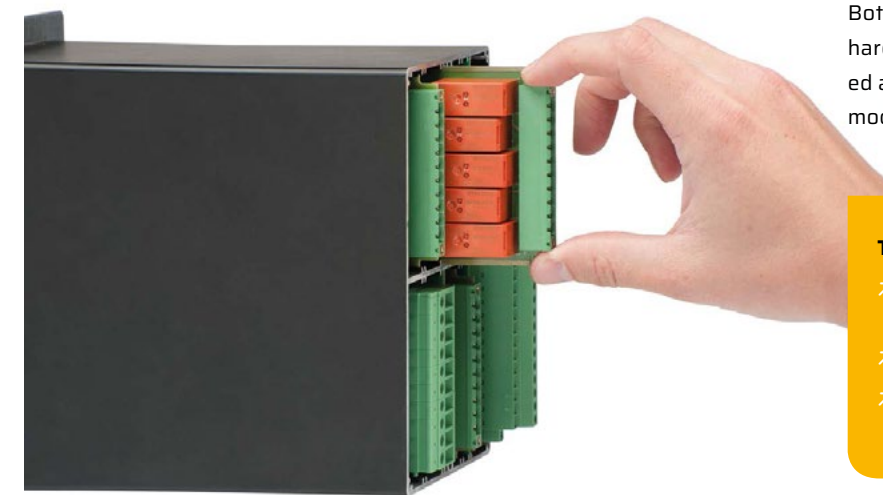

Both the AQ 210 and the AQ 250 series offer a modular software and hardware design. This means that devices in both series can be updated at any stage of their life cycle with additional I/O or communication modules for more comprehensive monitoring and control applications.

THE ONLY TRULY MODULAR DESIGN ON THE MARKET:

- Hardware and/or software upgrades at any point of the device life cycle.
- Upgrading can be done even on-site.
- Unique flexibility and reduced life cycle costs.

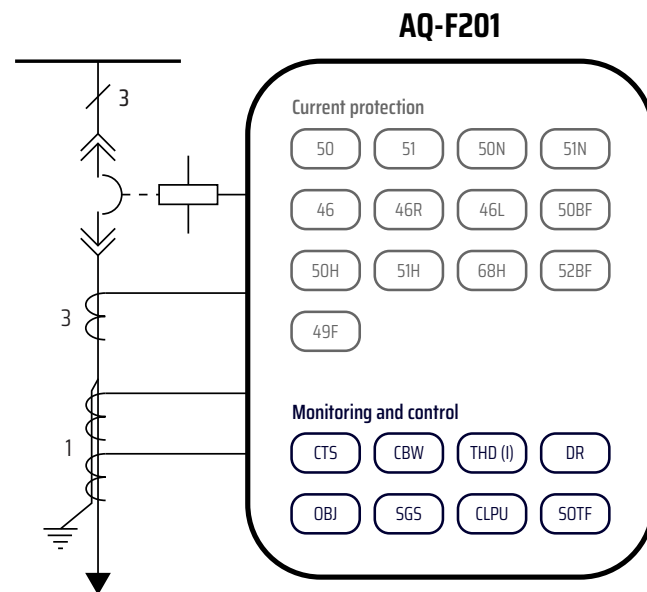

AQ-F201 Feeder protection device

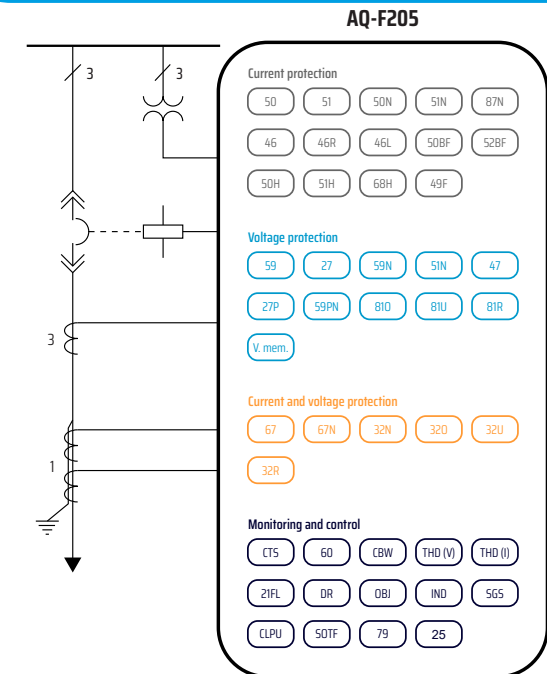

AQ-F205 Feeder protection device



READ MORE

The AQ-F201 overcurrent and ground fault device offers a compact solution for any application that requires non-directional overcurrent and ground fault protections. AQ-F201 has a selection of supportive functions for protection, measurement, monitoring, control, and communication as well as a large and programmable HMI. All of this guarantees the best price-performance ratio in basic protective devices.

HIGHLIGHTS:

- Basic range.
- Excellent price-performance ratio.

PROTECTION:

- Non-directional overcurrent (50/51)
- Non-directional ground fault (50N/51N)
- Negative sequence overcurrent / Phase current reversal / Current unbalance (46/46R/46L)
- Harmonic overcurrent (50H/51H/68H)
- Circuit breaker failure protection (50BF/52BF)
- Line thermal overload (49F)

CONTROL:

- Objects to control and monitor (OBJ): 1
- Setting groups (SGS): 8
- Cold load pick-up (CLPU)
- Switch-on-to-fault (SOTF)

MONITORING:

- Current transformer supervision (CTS)
- Voltage transformer supervision (60)
- Current total harmonic distortion (THD)
- Disturbance records: 100 (à 5 s 3.2 kHz sampling)
- Non-volatile event records: 15,000

MEASUREMENTS:

- Phase, sequence, and residual currents ($I_A, I_B, I_C, I_{01}, I_{02}$)

HARDWARE:

- **Standard features:**
 - Digital inputs: 3
 - Digital outputs: 5 + 1
 - Current inputs: 5

COMMUNICATION:

- **Standard inputs:**
 - 1 port with RJ-45 Ethernet 100 MB (front)
 - 1 port with RJ-45 Ethernet 100 MB (rear, COM A)
 - 1 port with RS-485 (rear, COM B)
- **Protocols:**
 - IEC 60870-5-101/104
 - IEC 60870-5-103
 - Modbus/RTU and Modbus/TCP
 - DNP3
 - SPA



READ MORE

The AQ-F205 feeder protection device is suitable for any application that requires directional overcurrent and ground fault protections along with voltage and frequency protections. The AQ-F205 feeder protection device comes with complimentary measurement, monitoring, control, and communication features. The relay's standard configuration of 11 digital inputs and 10 digital outputs along with a large, programmable HMI allow for a variety of adaptations.

HIGHLIGHTS:

- Integrated protection, control, and measurement.
- Excellent price-performance ratio.

PROTECTION:

- Non-directional overcurrent (50/51)
- Non-directional ground fault (50N/51N)
- Directional overcurrent (67)
- Directional ground fault (67N/32N)
- Negative sequence overcurrent / Phase current reversal / Current unbalance (46/46R/46L)
- Harmonic overcurrent (50H/51H/68H)
- Circuit breaker failure protection (50BF/52BF)
- High- and low-impedance restricted ground fault / Cable-end differential (87N)
- Overvoltage (59)
- Undervoltage (27)
- Neutral overvoltage (59N)
- Sequence voltage (47/27P/59PN)
- Over- and underfrequency (810/81U)
- Rate-of-change of frequency (81R)
- Overpower (320)
- Underpower (32U)
- Reverse power (32R)
- Line thermal overload (49F)
- Voltage memory

CONTROL:

- Objects to control and monitor (OBJ): 5
- Indicator objects to monitor (IND): 5
- Setting groups (SGS): 8
- Cold load pick-up (CLPU)
- Switch-on-to-fault (SOTF)
- Auto-recloser (79)
- Synchrocheck (25)

MONITORING:

- Current transformer supervision (CTS)
- Voltage transformer supervision (60)
- Circuit breaker wear monitoring (CBW)
- Current total harmonic distortion (THD)
- Voltage total harmonic distortion (THD)
- Fault locator (21FL)
- Disturbance records: 100 (à 5 s 3.2 kHz sampling)
- Non-volatile event records: 15,000

MEASUREMENTS:

- Phase, sequence, and residual currents ($I_A, I_B, I_C, I_{01}, I_{02}$)
- Phase, sequence, and residual voltages ($V_A, V_B, V_C, V_{AB}, V_{BC}, V_{CA}, V_{CB}$)
- Frequency (f)
- Power (P, Q, S, cos φ) and energy (E+, E-, Eq+, Eq-)

HARDWARE:

- **Standard features:**
 - Digital inputs: 11
- **Digital outputs: 10 + 1**
 - Current inputs: 5
 - Voltage inputs: 4
- **COMMUNICATION:**
 - **Standard inputs:**
 - 1 port with RJ-45 Ethernet 100 MB (front)
 - 1 port with RJ-45 Ethernet 100 MB (rear, COM A)
 - 1 port with RS-485 (rear, COM B)
 - **Protocols:**
 - IEC 60870-5-101/104
 - IEC 60870-5-103
 - Modbus/RTU and Modbus/TCP
 - DNP3
 - SPA

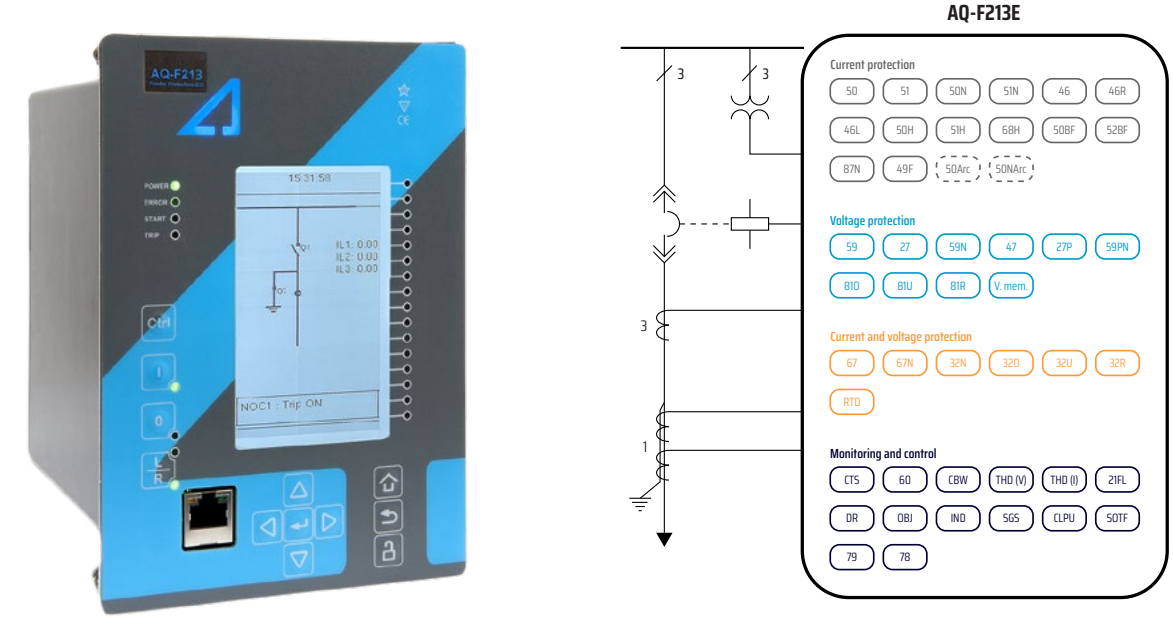
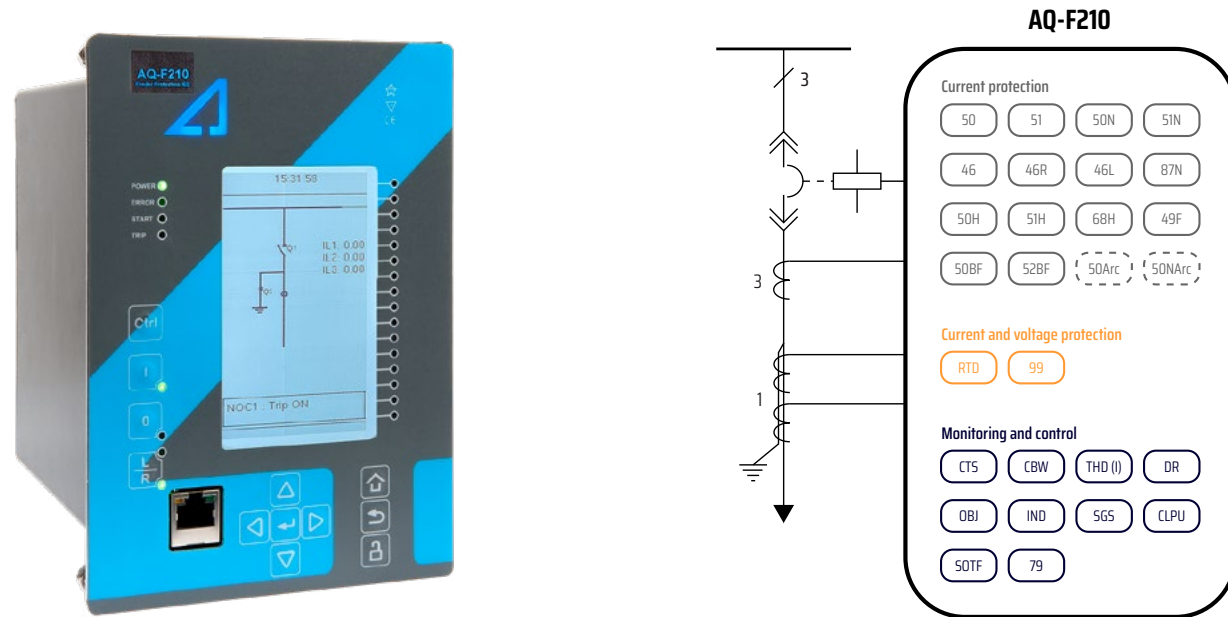

AQ-F210 Feeder protection device

AQ-F213 Feeder protection device



The AQ-F210 feeder protection device offers a modular feeder protection and control solution, with non-directional overcurrent and ground fault protections with an automatic recloser. You can add up to 4 I/O or communication modules into the device for more comprehensive monitoring and control applications. The AQ-F210 feeder protection device communicates using various protocols, including the IEC 61850.

HIGHLIGHTS:

- Cable-end differential protection.
- Low-impedance restricted ground fault protection.
- Harmonics protection and control (up to 31st).
- 5-shot scheme-controlled auto-recloser.

PROTECTION:

- Non-directional overcurrent (50/51)
- Non-directional ground fault (50N/51N)
- Negative sequence overcurrent / Phase current reversal / Current unbalance (46/46R/46L)
- Harmonic overcurrent (50H/51H/68H)
- Circuit breaker failure protection (50BF/52BF)
- High- and low-impedance restricted ground fault / Cable-end differential (87N)
- Resistance temperature detectors (RTD)
- Line thermal overload (49F)
- Programmable stage (99)
- Arc protection (50Arc/50Narc) (optional)

CONTROL:

- Objects to control and monitor (OBJ): 5
- Indicator objects to monitor (IND): 5
- Setting groups (SGS): 8
- Cold load pick-up (CLPU)
- Switch-on-to-fault (SOTF)
- Auto-recloser (79)

MONITORING:

- Current transformer supervision (CTS)
- Circuit breaker wear monitoring (CBW)
- Current total harmonic distortion (THD)
- Disturbance records: 100 (à 5 s 3.2 kHz sampling)
- Non-volatile event records: 15,000

MEASUREMENTS:

- Phase, sequence, and residual currents ($I_A, I_B, I_C, I_{01}, I_{02}$)

HARDWARE:

- **Standard features:**
 - Digital inputs: 3
 - Output relays: 5
 - Current inputs: 5
 - Empty module slots: 4
- **Optional hardware modules:**
 - Digital input module: 8 inputs
 - Digital output module: 5 outputs
 - Milliampere I/O module: 4 outputs + 1 input
 - Arc protection module: 4 sensors + 2 HSO + 1 BI
 - External I/O modules (see the "Accessories" page)

COMMUNICATION:

- **Standard inputs:**
 - 1 port with RJ-45 Ethernet 100 MB (front)
 - 1 port with RJ-45 Ethernet 100 MB (rear, COM A)
 - 1 port with RS-485 (rear, COM B)
- **Optional modules:**
 - 2 × RJ-45 Ethernet (100 MB/s) + IRIG-B input
 - 2 × ST Ethernet (100 MB/s) + IRIG-B input
 - 2 × LC Ethernet (100 MB/s, PRP/HSR)
 - RS-232 serial fiber (PP/PG/GP/PP)
- **Protocols:**
 - IEC 60870-5-101/104
 - IEC 60870-5-103
 - Modbus/RTU and Modbus/TCP
 - DNP3
 - SPA



The AQ-F213 feeder protection device provides optimal performance for medium-voltage (main) or high-voltage (back-up) protection, control, and monitoring applications. AQ-F213 integrates protection, control, monitoring, measuring, communication, and extensive diagnostics information in one compact package. The device has a fully modular hardware construction with 3 empty I/O slots. This gives the device a high level of flexibility as you can simply plug in additional I/O or communication modules according to application needs.

The best characteristic of AQ-F213 is its modularity: you can have the basic device (AQ-F213A) in storage until you know exactly the kind of functionality its use will require. Then, you only need the necessary modules and a new script to make it into the variant required by your application!

The development of the AQ-F213 feeder protection device uses the latest available technologies, which provides protection engineers with more options and a completely new dimension to protection. The device has many features which guarantee its maximum usability. These include

SOFTWARE OPTIONS:

- AQ-F213A - basic feeder protections
- AQ-F213B - basic feeder protections + IEC 61850 (1st Edition)
- AQ-F213C - basic feeder protections + directional ground fault protection + voltage protections + IEC 61850 (1st Edition)
- AQ-F213D - advanced feeder protection + fault locator
- AQ-F213E - full feeder functionality

HIGHLIGHTS:

- 5 software package options for different feeder needs: modify the basic AQ-F213A with necessary modules and a new script to transform it into the device you need.
- Low-impedance restricted ground fault protection.
- Harmonics protection and control (up to 31st).
- 5-shot scheme-controlled auto-recloser.
- IEC 61850 communication protocol (1st Edition).

the highly customizable graphic interface, the ability to store PDF files and other supportive documents, and extensive user log information. Additionally, the powerful configuration and setting software tools are easy to configure and free of charge.

Protection		AQ-F213A, -B, C, D, E
Non-directional overcurrent (50/51)		•
Non-directional ground fault (50N/51N)		•
Directional overcurrent (67)		D, E
Directional ground fault (67N/32N)		C, D, E
Negative sequence overcurrent / Phase current reversal / Current unbalance (46/46R/46L)		•
Harmonic overcurrent (50H/51H/68H)		•
Circuit breaker failure protection (50BF/52BF)		•
High- and low-impedance restricted ground fault / Cable-end differential (87N)		•
Overvoltage (59)		C, D, E
Undervoltage (27)		C, D, E
Neutral overvoltage (59N)		C, D, E
Sequence voltage (47/27P/59PN)		E
Over- and underfrequency (810/81U)		D, E
Rate-of-change of frequency (81R)		E
Overpower (320)		E
Underpower (32U)		E
Reverse power (32R)		E
Line thermal overload (49F)		•
Resistance temperature detectors (RTD)		•
Voltage memory		•
Arc protection (50Arc/50Narc) (optional)		•
Control		
Objects to control and monitor (OBJ): 5		•
Indicator objects to monitor (IND): 5		•
Setting groups (SGS): 8		•
Cold load pick-up (CLPU)		•
Switch-on-to-fault (SOTF)		•
Auto-recloser (79)		•
Vector jump (78)		D, E
Monitoring		
Current transformer supervision (CTS)		•
Voltage transformer supervision (VTS; 60)		C, D, E
Circuit breaker wear monitoring (CBW)		•
Current total harmonic distortion (THD)		C, D, E
Voltage total harmonic distortion (THD)		C, D, E
Fault locator (21FL)		D, E
Disturbance records: 100 (à 5 s 3.2 kHz sampling)		•
Non-volatile event records: 15,000		•
Measurements		
Phase, sequence, and residual currents ($I_A, I_B, I_C, I_{01}, I_{02}$)		B, C, D, E
Phase, sequence, and residual voltages ($V_A, V_B, V_C, V_{AB}, V_{BC}, V_{CA}, V_D$)		C, D, E
Frequency (f)		C, D, E
Power (P, Q, S, cos φ) and energy (E+, E-, Eq+, Eq-)		C, D, E
Hardware		
Standard features	Digital inputs: 6	•
	Digital outputs: 5	•
	Current inputs: 5	•
	Voltage inputs: 3	•
	Empty module slots: 3	•
Optional modules	Digital input module: 8 inputs	•
	Digital output module: 5 outputs	•
	Milliampere I/O module: 4 outputs + 1 input	•
	Arc protection module: 4 sensors + 2 HSO + 1 BI	•
External I/O modules (see the "Accessories" page)		•
Communication		
Comm. inputs	1 port with RJ-45 Ethernet 100 MB (front)	•
	1 port with RJ-45 Ethernet 100 MB (rear, COM A)	•
Optional modules	1 port with RS-485 (rear, COM B)	•
	2 × RJ-45 Ethernet (100 MB/s) + IRIG-B input	•
	2 × 5T Ethernet (100 MB/s) + IRIG-B input	•
	2 × LC Ethernet (100 MB/s, PRP/HSR)	•
	RS-232 serial fiber (PP/PD/GP/PP)	•
Communication protocols	IEC 61850 (1st Edition)	•
	IEC 60870-5-101/104	•
	IEC 60870-5-103	•
	Modbus/RTU and Modbus/TCP	•
	DNP3	•
	SPA	•

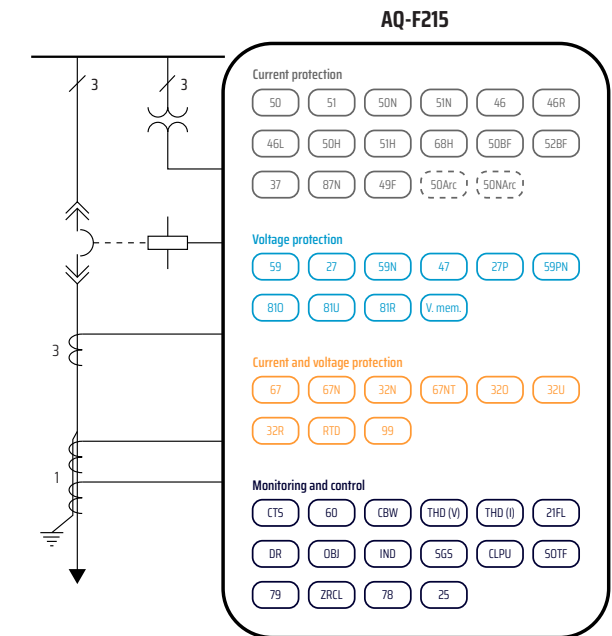

AQ-F215 Feeder protection device

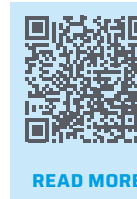

READ MORE

The AQ-F215 feeder protection device offers a modular feeder protection and control solution for applications that require both current-based and voltage-based protections as well as complete measurements. You can add up to 3 I/O or communication modules into the device for more comprehensive monitoring and control applications. The AQ-F215 feeder protection device communicates using various protocols, including the IEC 61850.

HIGHLIGHTS:

- Current- and voltage-based protections.
- Cable-end differential protection.
- Low-impedance restricted ground fault protection.
- Harmonics protection and control (up to 31st).
- 5-shot scheme-controlled auto-recloser.
- Optional power and energy measurement 0.2 %.

PROTECTION:

- Non-directional overcurrent (50/51)
- Non-directional ground fault (50N/51N)
- Directional overcurrent (67)
- Directional ground fault (67N/32N)
- Intermittent ground fault (67NT)
- Negative sequence overcurrent / Phase current reversal / Current unbalance (46/46R/46L)
- Harmonic overcurrent (50H/51H/68H)
- Circuit breaker failure protection (50BF/52BF)
- High- and low-impedance restricted ground fault / Cable-end differential (87N)
- Voltage-restrained overcurrent (51V)
- Overvoltage (59)
- Undervoltage (27)
- Neutral overvoltage (59N)
- Sequence voltage (47/27P/59PN)
- Over- and underfrequency (810/81U)
- Rate-of-change of frequency (81R)
- Overpower (320)
- Underpower (32U)
- Reverse power (32R)
- Line thermal overload (49F)
- Resistance temperature detectors (RTD)
- Programmable stage (99)
- Arc protection (50Arc/50Narc) (optional)
- Voltage memory

CONTROL:

- Objects to control and monitor (OBJ): 5
- Indicator objects to monitor (IND): 5
- Setting groups (SGS): 8
- Cold load pick-up (CLPU)
- Switch-on-to-fault (SOTF)
- Auto-recloser (79)
- Zero sequence recloser (79N)
- Vector jump (78)
- Synchrocheck (25)

MONITORING:

- Current transformer supervision (CTS)
- Circuit breaker wear monitoring (CBW)
- Current total harmonic distortion (THD)
- Disturbance records: 100 (à 5 s 3.2 kHz sampling)
- Non-volatile event records: 15,000

MEASUREMENTS:

- Phase, sequence, and residual currents ($I_A, I_B, I_C, I_{01}, I_{02}$)
- Phase, sequence, and residual voltages ($V_A, V_B, V_C, V_{AB}, V_{BC}, V_{CA}, V_D$)
- Frequency (f)
- Power (P, Q, S, cos φ) and energy (E+, E-, Eq+, Eq-)
- Power and energy measurement accuracy 0.5
- Power and energy measurement accuracy 0.2% (optional)

HARDWARE:

- **Standard features:**
 - Digital inputs: 3
 - Output relays: 5
 - Current inputs: 5
 - Voltage inputs: 4
 - Empty module slots: 3
- **Optional hardware modules:**
 - Digital input module: 8 inputs
 - Digital output module: 5 outputs
 - Milliampere I/O module: 4 outputs + 1 input
 - Arc protection module: 4 sensors + 2 HSO + 1 BI
 - External I/O modules (see the "Accessories" page)

COMMUNICATION:

- **Standard inputs:**
 - 1 port with RJ-45 Ethernet 100 MB (front)
 - 1 port with RJ-45 Ethernet 100 MB (rear, COM A)
 - 1 port with RS-485 (rear, COM B)
- **Optional modules:**
 - 2 × RJ-45 Ethernet (100 MB/s) + IRIG-B input
 - 2 × 5T Ethernet (100 MB/s) + IRIG-B input
 - 2 × LC Ethernet (100 MB/s, PRP/HSR)
 - RS-232 serial fiber (PP/PD/GP/PP)
- **Protocols:**
 - IEC 61850 (1st Edition)
 - IEC 60870-5-101/104
 - IEC 60870-5-103
 - Modbus/RTU and Modbus/TCP
 - DNP3
 - SPA

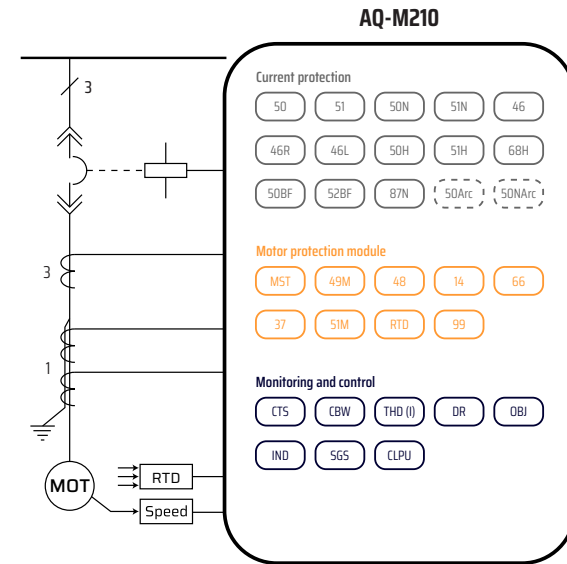

AQ-M210 Motor protection device



READ MORE

The AQ-M210 motor protection device offers a modular protection and control solution for small and medium-sized motors. You can add up to 4 I/O or communication modules into the device for more comprehensive monitoring and control applications. You can also connect up to 12 RTD signals for thermal alarming and tripping. AQ-M210 communicates using various protocols, including the IEC 61850.

HIGHLIGHTS:

- 5 thermal models (time constant accurate).
- Soft start protection begins at 6 Hz.
- Wye-delta started motor supervision.
- Two-speed motor protection.

PROTECTION:

- Non-directional overcurrent (50/51)
- Non-directional ground fault (50N/51N)
- Negative sequence overcurrent / Phase current reversal / Current unbalance (46/46R/46L)
- Harmonic overcurrent (50H/51H/68H)
- Circuit breaker failure protection (50BF/52BF)
- High- and low-impedance restricted ground fault / Cable-end differential (87N)
- Resistance temperature detectors (RTD)
- Motor status monitoring (MST)
- Machine thermal overload (49M)
- Motor start / Locked rotor monitoring (48/14)
- Frequent start (66)
- Non-directional undercurrent (37)
- Mechanical jam (51M)
- Programmable stage (99)
- Arc protection (50Arc/50Narc) (optional)

CONTROL:

- Objects to control and monitor (OBJ): 5
- Indicator objects to monitor (IND): 5
- Setting groups (SGS): 8
- Cold load pick-up (CLPU)

MONITORING:

- Current transformer supervision (CTS)
- Circuit breaker wear monitoring (CBW)
- Current total harmonic distortion (THD)
- Disturbance records: 100 (à 5 s 3.2 kHz sampling)
- Non-volatile event records: 15,000

MEASUREMENTS:

- Phase, sequence, and residual currents ($I_A, I_B, I_C, I_{01}, I_{02}$)

HARDWARE:

- **Standard features:**
 - Digital inputs: 3
 - Output relays: 5
 - Current inputs: 5
 - Empty module slots: 4
- **Optional hardware modules:**
 - Digital input module: 8 inputs
 - Digital output module: 5 outputs
 - Milliampere I/O module: 4 outputs + 1 input
 - Arc protection module: 4 sensors + 2 HSO + 1 BI
 - External I/O modules (see the "Accessories" page)

COMMUNICATION:

- **Standard inputs:**
 - 1 port with RJ-45 Ethernet 100 MB (front)
 - 1 port with RJ-45 Ethernet 100 MB (rear, COM A)
 - 1 port with RS-485 (rear, COM B)
 - 2 x RJ-45 Ethernet (100 MB/s) + IRIG-B input
 - 2 x ST Ethernet (100 MB/s) + IRIG-B input
 - 2 x LC Ethernet (100 MB/s, PRP/HSR)
 - RS-232 serial fiber (PP/PG/GP/PP)
- **Protocols:**
 - IEC 61850 (1st Edition)
 - IEC 60870-5-101/104
 - IEC 60870-5-103
 - Modbus/RTU and Modbus/TCP
 - DNP3
 - SPA

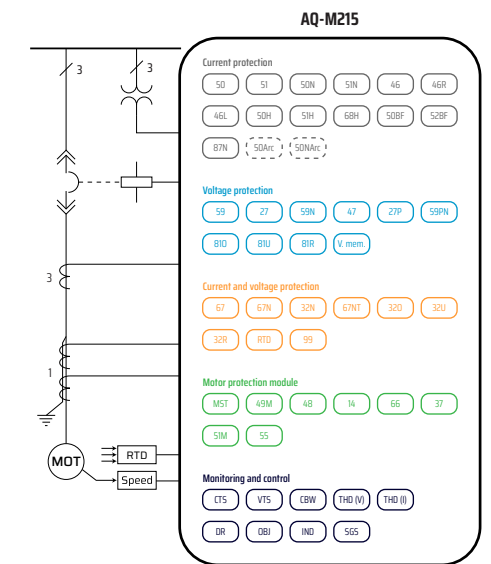

AQ-M215 Motor protection device



READ MORE

The AQ-M215 motor protection device offers a modular protection and control solution for larger and more important motors that require both current-based and voltage-based protection functions along with complete measurements. You can add up to 3 I/O or communication modules into the device for more comprehensive monitoring and control applications. You can also connect up to 16 RTD signals for thermal alarming and tripping. AQ-M215 communicates using various protocols, including the IEC 61850.

HIGHLIGHTS:

- Powerful motor management.
- 5 thermal models (time constant accurate).
- Soft start protection begins at 6 Hz.
- Wye-delta started motor supervision.
- Two-speed motor protection.
- Optional power and energy measurement of 0.2 %.

PROTECTION:

- Non-directional overcurrent (50/51)
- Non-directional ground fault (50N/51N)
- Directional overcurrent (67)
- Directional ground fault (67N/32N)
- Intermittent ground fault (67NT)
- Negative sequence overcurrent / Phase current reversal / Current unbalance (46/46R/46L)
- Harmonic overcurrent (50H/51H/68H)
- Circuit breaker failure protection (50BF/52BF)
- High- and low-impedance restricted ground fault / Cable-end differential (87N)
- Undervoltage (59)
- Neutral overvoltage (59N)
- Sequence voltage (47/27P/59PN)
- Over- and underfrequency (810/81U)
- Rate-of-change of frequency (81R)
- Overpower (320)
- Underpower (32U)
- Reverse power (32R)
- Resistance temperature detectors (RTD)
- Motor status monitoring (MST)
- Machine thermal overload (49M)
- Motor start / Locked rotor monitoring (48/14)
- Frequent start (66)
- Non-directional undercurrent (37)
- Mechanical jam (51M)
- Power factor (55)

- Programmable stage (99)
- Arc protection (50Arc/50Narc) (optional)
- Voltage memory

CONTROL:

- Objects to control and monitor (OBJ): 5
- Indicator objects to monitor (IND): 5
- Setting groups (SGS): 8

MONITORING:

- Current transformer supervision (CTS)
- Circuit breaker wear monitoring (CBW)
- Current total harmonic distortion (THD)
- Disturbance records: 100 (à 5 s 3.2 kHz sampling)
- Non-volatile event records: 15,000

MEASUREMENTS:

- Phase, sequence, and residual currents ($I_A, I_B, I_C, I_{01}, I_{02}$)
- Phase, sequence, and residual voltages ($V_A, V_B, V_C, V_{AB}, V_{BC}, V_{CA}, V_0$)
- Frequency (f)
- Power (P, Q, S, cos φ) and energy (E+, E-, Eq+, Eq-)
- Power and energy measurement accuracy 0.5
- Power and energy measurement accuracy 0.2% (optional)

HARDWARE:

- **Standard features:**
 - Digital inputs: 3
 - Output relays: 5

- Current inputs: 5
- Voltage inputs: 4
- Empty module slots: 3
- **Optional hardware modules:**
 - Digital input module: 8 inputs
 - Digital output module: 5 outputs
 - Milliampere I/O module: 4 outputs + 1 input
 - Arc protection module: 4 sensors + 2 HSO + 1 BI
 - External I/O modules (see the "Accessories" page)

COMMUNICATION:

- **Standard inputs:**
 - 1 port with RJ-45 Ethernet 100 MB (front)
 - 1 port with RJ-45 Ethernet 100 MB (rear, COM A)
 - 1 port with RS-485 (rear, COM B)
- **Optional modules:**
 - 2 x RJ-45 Ethernet (100 MB/s) + IRIG-B input
 - 2 x ST Ethernet (100 MB/s) + IRIG-B input
 - 2 x LC Ethernet (100 MB/s, PRP/HSR)
 - RS-232 serial fiber (PP/PG/GP/PP)
- **Protocols:**
 - IEC 61850 (1st Edition)
 - IEC 60870-5-101/104
 - IEC 60870-5-103
 - Modbus/RTU and Modbus/TCP
 - DNP3
 - SPA

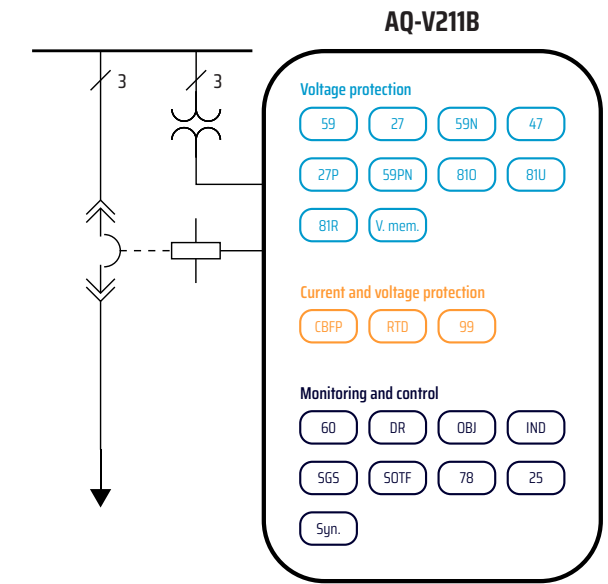
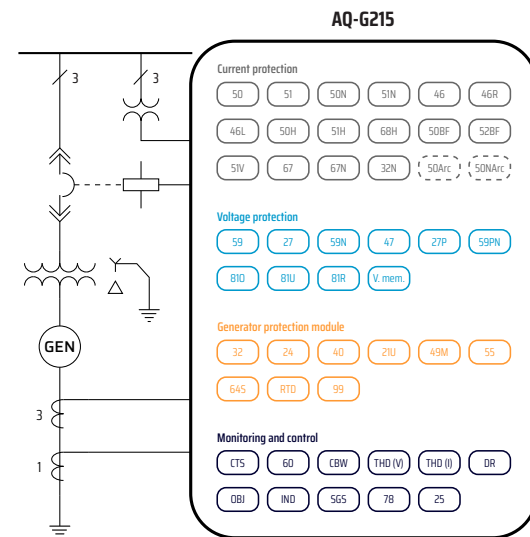

AQ-G215 Generator protection device

AQ-V211 Voltage protection device



READ MORE

The AQ-G215 generator protection device is well-suited for machines that require complete generator protections. AQ-G215 can be combined with AQ-T216 to protect larger machines that also require differential protection and greater protection redundancy. AQ-G215 communicates using various protocols, including the IEC 61850.

HIGHLIGHTS:

- Cost-efficient synchronous machine protection.
- Basic range of functionality.

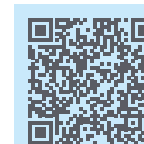

READ MORE

The AQ-V211 voltage protection device offers a modular voltage protection solution for substations. The relay includes both voltage and frequency protections as well as powerful logic programming, and you can add up to 5 I/O or communication modules. All this makes AQ-V21x optimal for demanding load shedding and automatic transfer applications. AQ-V211 communicates using various protocols, including the IEC 61850.

HIGHLIGHTS:

- 8 frequency stages and 8 setting groups for load shedding.
- Synchrocheck for up to 3 circuit breakers.
- Optional synchronizer function.
- Anti-islanding protection.

PROTECTION:

- Non-directional overcurrent (50/51)
- Non-directional ground fault (50N/51N)
- Directional overcurrent (67)
- Directional ground fault (67N/32N)
- Negative sequence overcurrent / Phase current reversal / Current unbalance (46/46R/46L)
- Harmonic overcurrent (50H/51H/68H)
- Circuit breaker failure protection (50BF/52BF)
- Voltage-restrained overcurrent (51V)
- Overvoltage (59)
- Undervoltage (27)
- Neutral overvoltage (59N)
- Sequence voltage (47/27P/59PN)
- Over- and underfrequency (810/81U)
- Rate-of-change of frequency (81R)
- Power (32)
- Volts-per-hertz overexcitation (24)
- Underexcitation (40)
- Underimpedance (21U)
- Resistance temperature detectors (RTD)
- Machine thermal overload (49M)
- Power factor (55)
- 100 % stator ground fault (64S)
- Programmable stage (99)
- Arc protection (50Arc/50Narc) (optional)
- Voltage memory

CONTROL:

- Objects to control and monitor (OBJ): 5
- Indicator objects to monitor (IND): 5
- Setting groups (SGS): 8
- Vector jump (78)
- Synchrocheck (25)

MONITORING:

- Current transformer supervision (CTS)
- Voltage transformer supervision (VTS; 60)
- Circuit breaker wear monitoring (CBW)
- Current total harmonic distortion (THD)
- Voltage total harmonic distortion (THD)
- Disturbance records: 100 (à 5 s 3.2 kHz sampling)
- Non-volatile event records: 15,000

MEASUREMENTS:

- Phase, sequence, and residual currents ($I_A, I_B, I_C, I_{01}, I_{02}$)
- Phase, sequence, and residual voltages ($V_A, V_B, V_C, V_{AB}, V_{BC}, V_{CA}, V_0$)
- Frequency (f)
- Power (P, Q, S, cos ϕ) and energy (E+, E-, Eq+, Eq-)
- Power and energy measurement accuracy 0.5
- Power and energy measurement accuracy 0.2 % (optional)

HARDWARE:

- **Standard features:**
 - Digital inputs: 3
 - Output relays: 5
 - Current inputs: 5
 - Voltage inputs: 4
 - Empty module slots: 3
- **Optional hardware modules:**
 - Digital input module: 8 inputs
 - Digital output module: 5 outputs
 - Milliampere I/O module: 4 outputs + 1 input
 - Arc protection module: 4 sensors + 2 HSO + 1 BI
 - External I/O modules (see the "Accessories" page)

COMMUNICATION:

- **Standard inputs:**
 - 1 port with RJ-45 Ethernet 100 MB (front)
 - 1 port with RJ-45 Ethernet 100 MB (rear, COM A)
 - 1 port with RS-485 (rear, COM B)
- **Optional modules:**
 - 2 x RJ-45 Ethernet (100 MB/s) + IRIG-B input
 - 2 x ST Ethernet (100 MB/s) + IRIG-B input
 - 2 x LC Ethernet (100 MB/s, PRP/HSR)
 - RS-232 serial fiber (PP/PG/GP/PP)
- **Protocols:**
 - IEC 61850 (1st Edition)
 - IEC 60870-5-101/104
 - IEC 60870-5-103
 - Modbus/RTU and Modbus/TCP
 - DNP3
 - SPA

SOFTWARE OPTIONS:

- AQ-V211A - standard voltage protections
- AQ-V211B - standard voltage protections + synchronizer

PROTECTION:

- Circuit breaker failure protection (50BF/52BF)
- Overvoltage (59)
- Undervoltage (27)
- Neutral overvoltage (59N)
- Sequence voltage (47/27P/59PN)
- Over- and underfrequency (810/81U)
- Rate-of-change of frequency (81R)
- Resistance temperature detectors (RTD)
- Programmable stage (99)
- Voltage memory

CONTROL:

- Objects to control and monitor (OBJ): 5
- Indicator objects to monitor (IND): 5
- Setting groups (SGS): 8
- Switch-on-to-fault (SOTF)
- Vector jump (78)
- Synchrocheck (25)
- Synchronizer (25) (AQ-V211B only)

MONITORING:

- Current transformer supervision (CTS)
- Circuit breaker wear monitoring (CBW)
- Current total harmonic distortion (THD)
- Disturbance records: 100 (à 5 s 3.2 kHz sampling)
- Non-volatile event records: 15,000

MEASUREMENTS:

- Phase, sequence, and residual voltages ($V_A, V_B, V_C, V_{AB}, V_{BC}, V_{CA}, V_0$)

HARDWARE:

- **Standard features:**
 - Digital inputs: 3
 - Output relays: 5
 - Voltage inputs: 4
 - Empty module slots: 5
- **Optional hardware modules:**
 - Digital input module: 8 inputs
 - Digital output module: 5 outputs
 - Milliampere I/O module: 4 outputs + 1 input
 - Arc protection module: 4 sensors + 2 HSO + 1 BI
 - External I/O modules (see the "Accessories" page)

COMMUNICATION:

- **Standard inputs:**
 - 1 port with RJ-45 Ethernet 100 MB (front)
 - 1 port with RJ-45 Ethernet 100 MB (rear, COM A)
 - 1 port with RS-485 (rear, COM B)
- **Optional modules:**
 - 2 x RJ-45 Ethernet (100 MB/s) + IRIG-B input
 - 2 x ST Ethernet (100 MB/s) + IRIG-B input
 - 2 x LC Ethernet (100 MB/s, PRP/HSR)
 - RS-232 serial fiber (PP/PG/GP/PP)
- **Protocols:**
 - IEC 61850 (1st Edition)
 - IEC 60870-5-101/104
 - IEC 60870-5-103
 - Modbus/RTU and Modbus/TCP
 - DNP3
 - SPA

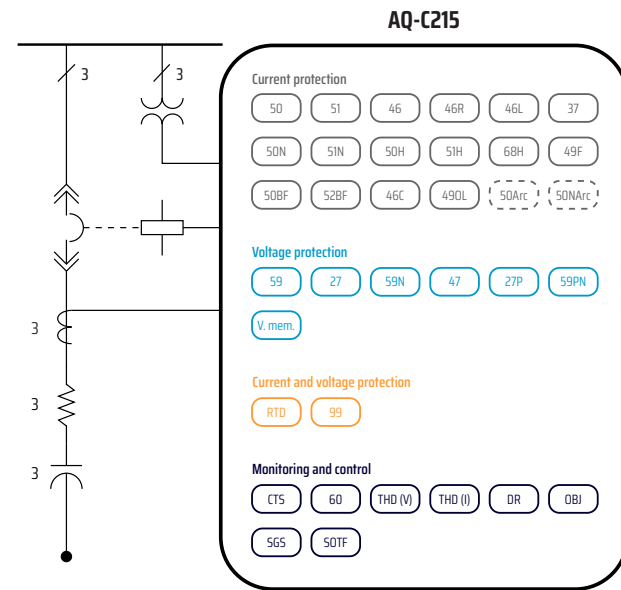

AQ-C215 Capacitor bank protection device



The AQ-C215 capacitor bank protection device has been specifically designed for the protection of capacitor banks. It includes capacitor bank current unbalance and overload protection in addition to standard overcurrent, ground fault and voltage protections. You can add up to 3 optional I/O or communication modules into the device for more comprehensive monitoring and control applications. AQ-C215 capacitor bank protection device communicates using various protocols, including the IEC 61850.

HIGHLIGHTS:

- Overcurrent, ground fault, and voltage protections.
- Capacitor bank current unbalance protection with natural unbalance compensation.
- Capacitor bank overload protection.
- Harmonic overcurrent protection (up to 31st).
- Current, voltage, energy, and power measurements.
- Up to 100 disturbance records.

PROTECTION:

- Non-directional overcurrent (50/51)
- Non-directional ground fault (50N/51N)
- Negative sequence overcurrent / Phase current reversal / Current unbalance (46/46R/46L)
- Harmonic overcurrent (50H/51H/68H)
- Circuit breaker failure protection (50BF/52BF)
- Capacitor bank current unbalance (46C)
- Capacitor bank overload (490L)
- Non-directional undercurrent (37)
- Overvoltage (59)
- Undervoltage (27)
- Neutral overvoltage (59N)
- Sequence voltage (47/27P/59PN)
- Resistance temperature detectors (RTD)
- Line thermal overload (49F)
- Programmable stage (99)
- Arc protection (50Arc/50Narc) (optional)
- Voltage memory

CONTROL:

- Objects to control and monitor (OBJ): 5
- Setting groups (SGS): 8
- Switch-on-to-fault (SOTF)

MONITORING:

- Current transformer supervision (CTS)
- Voltage transformer supervision (VTS; 60)
- Current total harmonic distortion (THD)
- Voltage total harmonic distortion (THD)
- Disturbance records: 100 (à 5 s 3.2 kHz sampling)
- Non-volatile event records: 15,000

MEASUREMENTS:

- Phase, sequence, and residual currents ($I_A, I_B, I_C, I_{01}, I_{02}$)
- Phase, sequence, and residual voltages ($V_A, V_B, V_C, V_{AB}, V_{BC}, V_{CA}, V_0$)
- Frequency (f)
- Power (P, Q, S, cos φ) and energy (E+, E-, Eq+, Eq-)
- Power and energy measurement accuracy 0.5
- Power and energy measurement accuracy 0.2% (optional)

HARDWARE:

- **Standard features:**
 - Digital inputs: 3
 - Output relays: 5
 - Current inputs: 5
 - Voltage inputs: 4
 - Empty module slots: 3

Optional hardware modules:

- Digital input module: 8 inputs
- Digital output module: 5 outputs
- Milliampere I/O module: 4 outputs + 1 input
- Arc protection module: 4 sensors + 2 HSO + 1 BI
- External I/O modules (see the "Accessories" page)

COMMUNICATION:

- **Standard inputs:**
 - 1 port with RJ-45 Ethernet 100 MB (front)
 - 1 port with RJ-45 Ethernet 100 MB (rear, COM A)
 - 1 port with RS-485 (rear, COM B)

Optional modules:

- 2 × RJ-45 Ethernet (100 MB/s) + IRIG-B input
- 2 × ST Ethernet (100 MB/s) + IRIG-B input
- 2 × LC Ethernet (100 MB/s, PRP/HSR)
- RS-232 serial fiber (PP/PG/GP/PP)

Protocols:

- IEC 61850 (1st Edition)
- IEC 60870-5-101/104
- IEC 60870-5-103
- Modbus/RTU and Modbus/TCP
- DNP3
- SPA

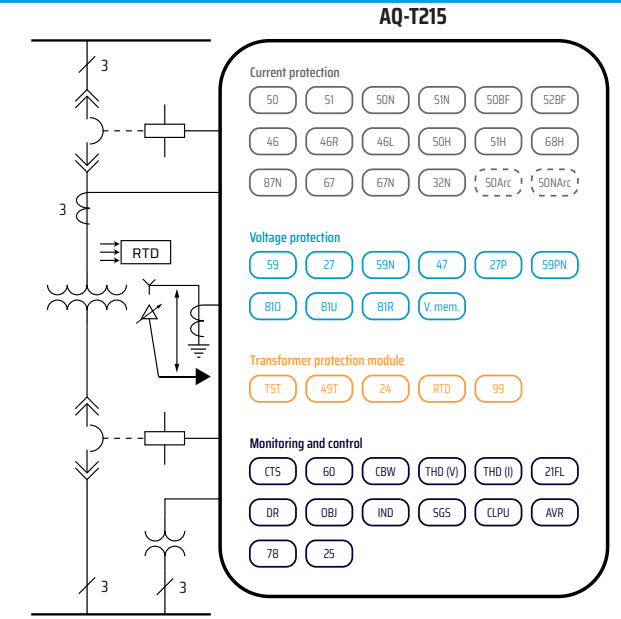

AQ-T215 Transformer protection device

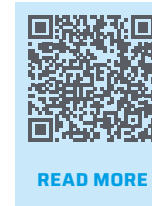

AQ-T215 is a voltage regulating device. It comes with current-based and voltage-based protection functions, which makes the relay suitable for combined transformer voltage regulation and back-up protection. The transformer monitoring module is included as a standard feature, and it provides statistical information for preventive maintenance purposes. AQ-T215 communicates using various protocols, including the IEC 61850.

HIGHLIGHTS:

- Automatic/manual voltage regulator (AVR).
- Transformer back-up protection.
- Overloading and through fault statistics for preventative maintenance.

PROTECTION:

- Non-directional overcurrent (50/51)
- Non-directional ground fault (50N/51N)
- Directional overcurrent (67)
- Directional ground fault (67N/32N)
- Negative sequence overcurrent / Phase current reversal / Current unbalance (46/46R/46L)
- Harmonic overcurrent (50H/51H/68H)
- Circuit breaker failure protection (50BF/52BF)
- High- and low-impedance restricted ground fault / Cable-end differential (87N)
- Overvoltage (59)
- Undervoltage (27)
- Neutral overvoltage (59N)
- Sequence voltage (47/27P/59PN)
- Over- and underfrequency (810/81U)
- Rate-of-change of frequency (81R)
- Volts-per-hertz overexcitation (24)
- Resistance temperature detectors (RTD)
- Transformer status monitoring (TRF)
- Transformer thermal overload (49T)
- Programmable stage (99)
- Arc protection (50Arc/50Narc) (optional)
- Voltage memory

CONTROL:

- Objects to control and monitor (OBJ): 5
- Indicator objects to monitor (IND): 5
- Setting groups (SGS): 8

- Cold load pick-up (CLPU)
- Automatic voltage regulator (AVR; 90)
- Vector jump (78)
- Synchrocheck (25)

MONITORING:

- Current transformer supervision (CTS)
- Voltage transformer supervision (VTS; 60)
- Circuit breaker wear monitoring (CBW)
- Current total harmonic distortion (THD)
- Voltage total harmonic distortion (THD)
- Fault locator (21FL)
- Disturbance records: 100 (à 5 s 3.2 kHz sampling)
- Non-volatile event records: 15,000

MEASUREMENTS:

- Phase, sequence, and residual currents ($I_A, I_B, I_C, I_{01}, I_{02}$)
- Phase, sequence, and residual voltages ($V_A, V_B, V_C, V_{AB}, V_{BC}, V_{CA}, V_0$)
- Frequency (f)
- Power (P, Q, S, cos φ) and energy (E+, E-, Eq+, Eq-)
- Power and energy measurement accuracy 0.5
- Power and energy measurement accuracy 0.2% (optional)

HARDWARE:

- **Standard features:**
 - Digital inputs: 3
 - Output relays: 5
 - Current inputs: 5

- Voltage inputs: 4
- Empty module slots: 3
- **Optional hardware modules:**
 - Digital input module: 8 inputs
 - Digital output module: 5 outputs
 - Milliampere I/O module: 4 outputs + 1 input
 - Arc protection module: 4 sensors + 2 HSO + 1 BI
 - External I/O modules (see the "Accessories" page)

COMMUNICATION:

- **Standard inputs:**
 - 1 port with RJ-45 Ethernet 100 MB (front)
 - 1 port with RJ-45 Ethernet 100 MB (rear, COM A)
 - 1 port with RS-485 (rear, COM B)
- **Optional modules:**
 - 2 × RJ-45 Ethernet (100 MB/s) + IRIG-B input
 - 2 × ST Ethernet (100 MB/s) + IRIG-B input
 - 2 × LC Ethernet (100 MB/s, PRP/HSR)
 - RS-232 serial fiber (PP/PG/GP/PP)
- **Protocols:**
 - IEC 61850 (1st Edition)
 - IEC 60870-5-101/104
 - IEC 60870-5-103
 - Modbus/RTU and Modbus/TCP
 - DNP3
 - SPA

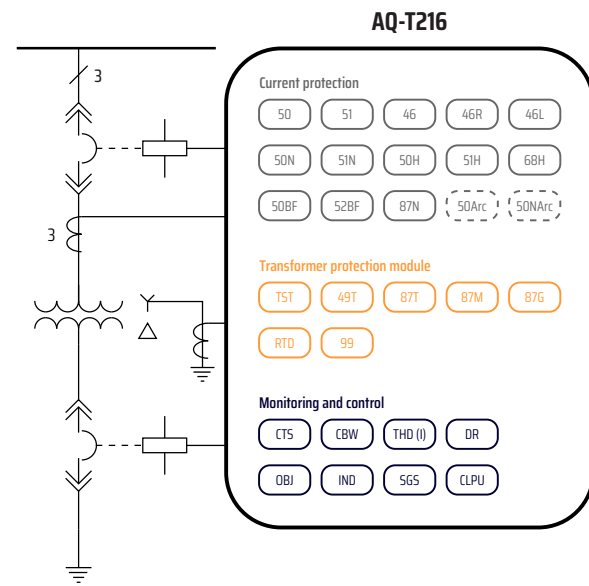

AQ-T216 Transformer protection device



READ MORE

AQ-T216 is a transformer protection device with sophisticated and easy-to-use differential protection functions. The relay provides overcurrent protection for both low-voltage and high-voltage sides, ground fault protection, negative sequence overcurrent protection as well as two independent instances of restricted ground fault protection. Additionally, AQ-T216 can be applied to generator and motor differential protection. AQ-T216 communicates using various protocols, including the IEC 61850.

HIGHLIGHTS:

- Both predefined and customizable connection group selection.
- 2nd and 5th harmonic blocking.
- Automatic verification for the connection group and nominal value settings.
- Overloading and through fault statistics for preventative maintenance.

PROTECTION:

- Non-directional overcurrent (50/51)
- Non-directional ground fault (50N/51N)
- Negative sequence overcurrent / Phase current reversal / Current unbalance (46/46R/46L)
- Harmonic overcurrent (50H/51H/68H)
- Circuit breaker failure protection (50BF/52BF)
- High- and low-impedance restricted ground fault / Cable-end differential (87N)
- Resistance temperature detectors (RTD)
- Transformer status monitoring (TRF)
- Transformer thermal overload (49T)
- Transformer/motor/generator differential (87T/87M/87G)
- Programmable stage (99)
- Arc protection (50Arc/50NArc) (optional)

CONTROL:

- Objects to control and monitor (OBJ): 5
- Indicator objects to monitor (IND): 5
- Setting groups (SGS): 8
- Cold load pick-up (CLPU)

MONITORING:

- Current transformer supervision (CTS) (2 instances)
- Circuit breaker wear monitoring (CBW)
- Current total harmonic distortion (THD)
- Disturbance records: 100 (à 5 s 3.2 kHz sampling)
- Non-volatile event records: 15,000

MEASUREMENTS:

- Phase, sequence, and residual currents ($I_A, I_B, I_C, I_{01}, I_{02}$)

HARDWARE:

- **Standard features:**
 - Digital inputs: 3
 - Output relays: 5
 - Current inputs: 10
 - Empty module slots: 2
- **Optional hardware modules:**
 - Digital input module: 8 inputs
 - Digital output module: 5 outputs
 - Milliampere I/O module: 4 outputs + 1 input
 - Arc protection module: 4 sensors + 2 HSO + 1 BI
 - External I/O modules (see the "Accessories" page)

COMMUNICATION:

- **Standard inputs:**
 - 1 port with RJ-45 Ethernet 100 MB (front)
 - 1 port with RJ-45 Ethernet 100 MB (rear, COM A)
 - 1 port with RS-485 (rear, COM B)
- **Optional modules:**
 - 2 x RJ-45 Ethernet (100 MB/s) + IRIG-B input
 - 2 x ST Ethernet (100 MB/s) + IRIG-B input
 - 2 x LC Ethernet (100 MB/s, PRP/HSR)
 - RS-232 serial fiber (PP/PG/GP/PP)
- **Protocols:**
 - IEC 61850 (1st Edition)
 - IEC 60870-5-101/104
 - IEC 60870-5-103
 - Modbus/RTU and Modbus/TCP
 - DNP3
 - SPA

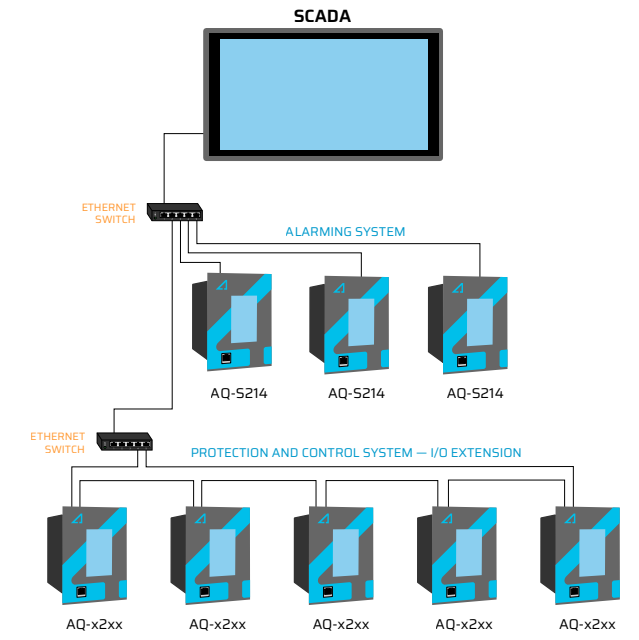

AQ-S214 Alarm and indication device

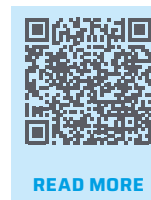

READ MORE

The AQ-S214 alarm and indication device can be applied to various substation tasks, such as extending the general I/O, sounding alarms, and control. You can add up to 6 I/O or communication modules into the device, depending on the requirements of your application. The logic programming is powerful and easy to use. This also further expands the device's application range towards more demanding control, alarm and indication needs. The HMI is large and can be freely programmed, and it provides a quick visualization of the object as well as the status of alarms and events. AQ-S214 communicates using various protocols, including the IEC 61850.

PROTECTION:

- Resistance temperature detectors (RTD)
- Programmable stage (99)

ALARM, CONTROL, AND INDICATIONS:

- Objects to control and monitor (OBJ): 10
- Indicator objects to monitor (IND): 5
- Setting groups (SGS): 8
- Alarms to program: 64
- Disturbance records: 100 (à 5 s 3.2 kHz sampling)
- Non-volatile event records: 15,000

HARDWARE:

- **Standard features:**
 - Digital inputs: 3
 - Output relays: 5
 - Empty module slots: 3

Optional hardware modules:

- Digital input module: 8 inputs
- Digital output module: 5 outputs
- Milliampere I/O module: 4 outputs + 1 input
- External I/O modules (see the "Accessories" page)

COMMUNICATION:

- **Standard inputs:**
 - 1 port with RJ-45 Ethernet 100 MB (front)
 - 1 port with RJ-45 Ethernet 100 MB (rear, COM A)
 - 1 port with RS-485 (rear, COM B)
- **Optional modules:**
 - 2 x RJ-45 Ethernet (100 MB/s) + IRIG-B input
 - 2 x ST Ethernet (100 MB/s) + IRIG-B input
 - 2 x LC Ethernet (100 MB/s, PRP/HSR)
 - RS-232 serial fiber (PP/PG/GP/PP)
- **Protocols:**
 - IEC 61850 (1st Edition)

HIGHLIGHTS:

- A dynamic view of up to 48 digital or analog alarms.
- A flexible, easy way to assign digital signals to the local alarm window, output relays, and communication protocols.
- Output relays can be activated by individual or group alarm signals.
- 6 available I/O card slots to enable a large number of signals.

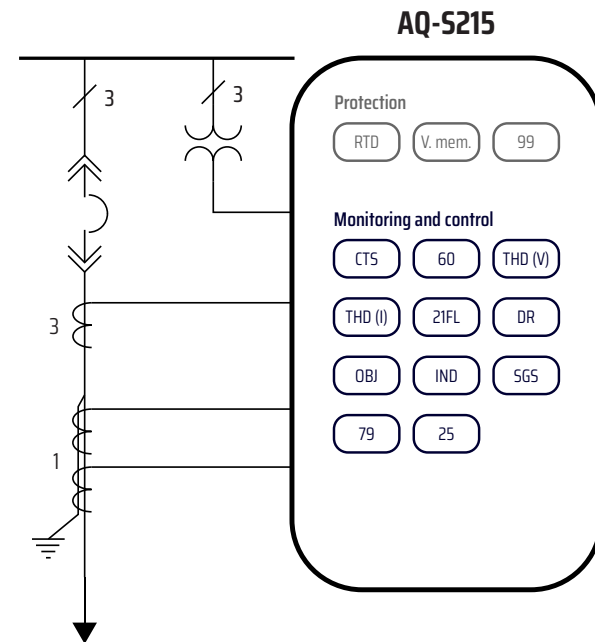

AQ-S215 Bay control device

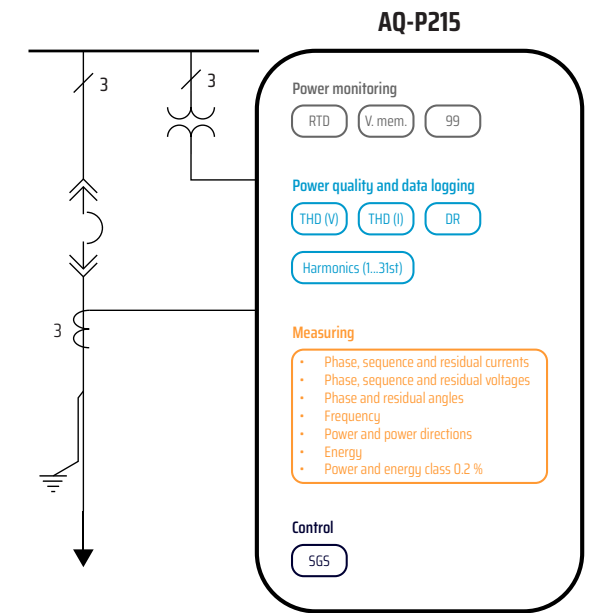

AQ-P215 Power monitoring device



READ MORE

The AQ-S215 bay control device can be applied to various types of control applications. AQ-S215 comes with full current, voltage, power and energy measurement capabilities, and the relay can be equipped with up to 3 I/O or communication modules, depending on the requirements of your application. The logic programming is powerful and easy to use, and it further expands the device's application range. The HMI is large and can be freely programmed, and provides a quick visualization of the status of objects, alarms, and events. AQ-S215 communicates using various protocols, including the IEC 61850.

HIGHLIGHTS:

- Smart grid control.
- Benefits of a smart distribution solution.
- Reduced wiring.
- Operational redundancy.
- Bay-oriented alarms and status windows.
- An integrated disturbance recorder function.

PROTECTION:

- Resistance temperature detectors (RTD)
- Programmable stage (99)
- Voltage memory

CONTROL:

- Objects to control and monitor (OBJ): 10
- Indicator objects to monitor (IND): 5
- Setting groups (SGS): 8
- Auto-recloser (79)
- Synchrocheck (25)

MONITORING:

- Current transformer supervision (CTS)
- Voltage transformer supervision (VTS; 60)
- Current total harmonic distortion (THD)
- Voltage total harmonic distortion (THD)
- Fault locator (21FL)
- Disturbance records: 100 (à 5 s 3.2 kHz sampling)
- Non-volatile event records: 15,000

MEASUREMENTS:

- Phase, sequence, and residual currents ($I_A, I_B, I_C, I_{01}, I_{02}$)
- Phase, sequence, and residual voltages ($V_A, V_B, V_C, V_{CA}, V_{CB}, V_{BC}, V_{CA}, V_{CB}$)
- Frequency (f)
- Power (P, Q, S, cos φ) and energy (E+, E-, Eq+, Eq-)
- Power and energy measurement accuracy 0.5
- Power and energy measurement accuracy 0.2% (optional)

HARDWARE:

- **Standard features:**
 - Digital inputs: 3
 - Output relays: 5
 - Current inputs: 5
 - Voltage inputs: 4
 - Empty module slots: 3
- **Optional hardware modules:**
 - Digital input module: 8 inputs
 - Digital output module: 5 outputs
 - Milliampere I/O module: 4 outputs + 1 input
 - External I/O modules (see the "Accessories" page)

COMMUNICATION:

- **Standard inputs:**
 - 1 port with RJ-45 Ethernet 100 MB (front)
 - 1 port with RJ-45 Ethernet 100 MB (rear, COM A)
 - 1 port with RS-485 (rear, COM B)
- **Optional modules:**
 - 2 × RJ-45 Ethernet (100 MB/s) + IRIG-B input
 - 2 × ST Ethernet (100 MB/s) + IRIG-B input
 - 2 × LC Ethernet (100 MB/s, PRP/HSR)
 - RS-232 serial fiber (PP/PG/GP/PP)
- **Protocols:**
 - IEC 61850 (1st Edition)
 - IEC 60870-5-101/104
 - IEC 60870-5-103
 - Modbus/RTU and Modbus/TCP
 - DNP3
 - SPA



READ MORE

AQ-P215 is a novel power monitoring device for demanding metering and power monitoring applications. AQ-P215 offers a unique combination: the high-accuracy power and energy measurement of 0.2% is paired with a dynamic measurement range of up to 250 A (secondary current). Data logging in the flash memory is freely configurable, and the programmable logic and disturbance recorder features allow for a variety of power quality monitoring applications. AQ-P215 communicates using various protocols, including the IEC 61850.

POWER MONITORING:

- Resistance temperature detectors (RTD)
- Programmable stage (99)
- Voltage memory
- Power quality and data logging:
 - Voltage and current harmonics (up to 31st)
 - Current total harmonic distortion (THD)
 - Voltage total harmonic distortion (THD)
 - Disturbance records: 100 (à 5 s 3.2 kHz sampling)
- Non-volatile event records: 15,000

CONTROL:

- Setting groups (SGS): 8

MEASUREMENTS:

- Phase, sequence, and residual currents ($I_A, I_B, I_C, I_{01}, I_{02}$)
- Phase, sequence, and residual voltages ($V_A, V_B, V_C, V_{AB}, V_{BC}, V_{CA}, V_{CB}$)
- Phase and residual angles
- Frequency (f)
- Power (P, Q, S) and energy (E+, E-, Eq+, Eq-)
- Power directions (tan φ and cos φ)
- Power and energy measurement accuracy 0.2%

HARDWARE:

- **Standard features:**
 - Digital inputs: 3
 - Output relays: 5
 - Current inputs: 5
 - Voltage inputs: 4
 - Empty module slots: 3
- **Optional hardware modules:**
 - Digital input module: 8 inputs
 - Digital output module: 5 outputs
 - Milliampere I/O module: 4 outputs + 1 input
 - External I/O modules (see the "Accessories" page)

COMMUNICATION:

- **Standard inputs:**
 - 1 port with RJ-45 Ethernet 100 MB (front)
 - 1 port with RJ-45 Ethernet 100 MB (rear, COM A)
 - 1 port with RS-485 (rear, COM B)
- **Optional modules:**
 - 2 × RJ-45 Ethernet (100 MB/s) + IRIG-B input
 - 2 × ST Ethernet (100 MB/s) + IRIG-B input
 - 2 × LC Ethernet (100 MB/s, PRP/HSR)

HIGHLIGHTS:

- Power and energy measurement accuracy of 0.2%.
- Patented frequency-independent measurement.
- The frequency-tracking algorithm guarantees a measurement accuracy of 6...75 Hz.
- Power quality analysis (harmonics, THD, and disturbance recording).
- Ultra-fast Modbus/TCP communication (5 ms update interval).
- A powerful disturbance recorder with a sampling rate of up to 64 samples per cycle.
- A dynamic measuring range of up to 250 A (secondary current); effective disturbance recording when coupled with a protection current transformer.
- A calendar feature with automatic adjustments for daylight savings time and leap years.
- Programmable logic functions.
- An extensive data logging capability.

- RS-232 serial fiber (PP/PG/GP/PP)
- **Protocols:**
 - IEC 61850 (1st Edition)
 - IEC 60870-5-101/104
 - IEC 60870-5-103
 - Modbus/RTU and Modbus/TCP
 - DNP3
 - SPA



AQ-R215 Railway protection device



READ MORE

AQ-R215 railway protection device is a three-phase feeder protection device that can be run either in Standard feeder mode or in Railway mode. In Railway mode the device provides a single-phase overcurrent, ground fault, and voltage protections. Each protection stage can be independently set to the frequency of 16.67 Hz or of 50/60 Hz. When in Standard mode the functionality of AQ-R215 is identical to that of the

AQ-F215 feeder protection device. In this mode the relay can also be dynamically set to run on a frequency between 6 and 75 Hz.

You can add up to 3 I/O or communication modules into the device for more demanding control, alarm and indication needs. AQ-R215 railway protection device communicates using various protocols, including the IEC 61850.

HIGHLIGHTS:

- Single-phase protection for any frequency range between 6 and 75 Hz.
- Double busbar control.
- Directional overcurrent and voltage protection.
- Low-impedance restricted ground fault protection.
- Harmonics protection (up to 31st).
- 5-shot scheme-controlled auto-recloser.

PROTECTION (RAILWAY MODE):

- Railway directional overcurrent (67)
- Railway non-directional ground fault (50N/51N)
- Railway voltage (27/59)

PROTECTION (STANDARD MODE):

- Non-directional overcurrent (50/51)
- Non-directional ground fault (50N/51N)
- Directional overcurrent (67)
- Directional ground fault (67N/32N)
- Intermittent ground fault (67NT)
- Negative sequence overcurrent / Phase current reversal / Current unbalance (46/46R/46L)
- Harmonic overcurrent (50H/51H/68H)
- Circuit breaker failure protection (50BF/52BF)
- High- and low-impedance restricted ground fault / Cable-end differential (87N)
- Overvoltage (59)
- Undervoltage (27)
- Neutral overvoltage (59N)
- Sequence voltage (47/27P/59PN)
- Over- and underfrequency (81O/81U)
- Rate-of-change of frequency (81R)
- Overpower (32O)
- Underpower (32U)
- Reverse power (32R)
- Resistance temperature detectors (RTD)
- Line thermal overload (49F)
- Programmable stage (99)
- Arc protection (50Arc/50Narc) (optional)
- Voltage memory

CONTROL:

- Objects to control and monitor (OBJ): 5
- Indicator objects to monitor (IND): 5
- Setting groups (SGS): 8
- Cold load pick-up (CLPU)
- Switch-on-to-fault (SOTF)
- Vector jump (78)
- Auto-recloser (79)
- Zero sequence recloser (79N)
- Synchrocheck (25)

MONITORING:

- Current transformer supervision (CTS)
- Voltage transformer supervision (VTS; 60)
- Circuit breaker wear monitoring (CBW)
- Current total harmonic distortion (THD)
- Voltage total harmonic distortion (THD)
- Fault locator (21FL)
- Disturbance records: 100 (á 5 s 3.2 kHz sampling)
- Non-volatile event records: 15,000

MEASUREMENTS:

- Phase, sequence, and residual currents ($I_A, I_B, I_C, I_{D1}, I_{D2}$)
- Phase, sequence, and residual voltages ($V_A, V_B, V_C, V_{AB}, V_{BC}, V_{CA}, V_D$)
- Frequency (f)
- Power (P, Q, S, cos φ) and energy (E+, E-, Eq+, Eq-)
- Power and energy measurement accuracy 0.5
- Power and energy measurement accuracy 0.2 % (optional)

HARDWARE:

- **Standard features:**
 - Digital inputs: 3
 - Output relays: 5
 - Current inputs: 5
 - Voltage inputs: 4
 - Empty module slots: 3
- **Optional hardware modules:**
 - Digital input module: 8 inputs
 - Digital output module: 5 outputs
 - Milliampere I/O module: 4 outputs + 1 input
 - Arc protection module: 4 sensors + 2 HSO + 1 BI
 - External I/O modules (see the "Accessories" page)

COMMUNICATION:

- **Standard inputs:**
 - 1 port with RJ-45 Ethernet 100 MB (front)
 - 1 port with RJ-45 Ethernet 100 MB (rear, COM A)
 - 1 port with RS-485 (rear, COM B)
- **Optional modules:**
 - 2 x RJ-45 Ethernet (100 MB/s) + IRIG-B input
 - 2 x ST Ethernet (100 MB/s) + IRIG-B input
 - 2 x LC Ethernet (100 MB/s, PRP/HSR)
 - RS-232 serial fiber (PP/GP/GG/PP)
- **Protocols:**
 - IEC 61850 (1st Edition)
 - IEC 60870-5-101/104
 - IEC 60870-5-103
 - Modbus/RTU and Modbus/TCP
 - DNP3
 - SPA



AQ-F255 Feeder protection device



READ MORE

The AQ-F255 feeder protection device offers a modular feeder protection and control solution for applications that require a large I/O capacity. You can add up to total 11 option modules (I/O and other type of modules) into the device for extensive monitoring and control applications. The AQ-F255 feeder protection device communicates using various protocols, including the IEC 61850.

SOFTWARE OPTIONS:

- AQ-F255A - full feeder functionality
- AQ-F255R - full feeder functionality + special object for phase-specific tripping and recloser control
- AQ-F255S - full feeder functionality + synchronizer
- AQ-F255V - full feeder functionality + AVR + transformer module

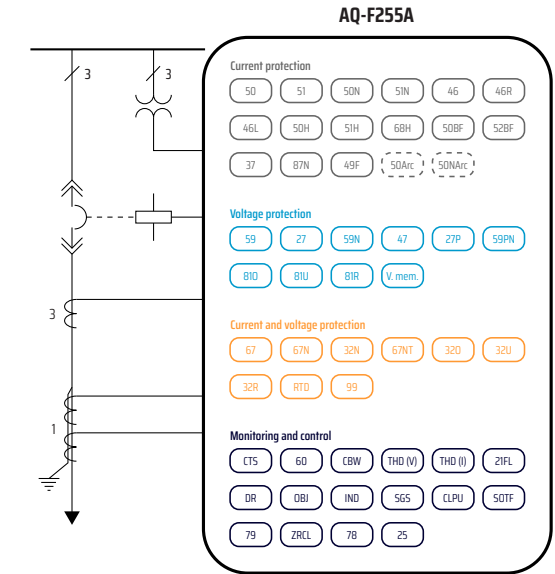

HIGHLIGHTS:

- A large I/O capacity.
- Double busbar control.
- Optional automatic/manual voltage regulation and/or parallel voltage regulation (AVR).
- Optional transformer module protections.
- 5-shot scheme-controlled auto-recloser.
- Optional power and energy measurement accuracy of 0.2 %.
- Includes IEC 61850 2nd Edition.

Protection	AQ-F255A, -R, S, V
Non-directional overcurrent (50/51)	•
Non-directional ground fault (50N/51N)	•
Single-pole non-directional overcurrent (50/51)	R
Directional overcurrent (67)	•
Directional ground fault (67N/32N)	•
Intermittent ground fault (67NT)	•
Negative sequence overcurrent / Phase current reversal / Current unbalance (46/46R/46L)	•
Harmonic overcurrent (50H/51H/68H)	•
Circuit breaker failure protection (50BF/52BF)	•
High- and low-impedance restricted ground fault / Cable-end differential (87N)	•
Voltage-restrained overcurrent (51V)	•
Overvoltage (59)	•
Undervoltage (27)	•
Neutral overvoltage (59N)	•
Sequence voltage (47/27P/59PN)	•
Over- and underfrequency (81O/81U)	•
Rate-of-change of frequency (81R)	•
Power protection (32)	V
Overpower (32O)	•
Underpower (32U)	•

Protection		AQ-F255A, -R, S, V
Reverse power (32R)		•
Line thermal overload (49F)		•
Resistance temperature detectors (RTD)		•
Transformer status monitoring (TST)		V
Transformer thermal overload (49T)		V
Underimpedance (21U)		V
Underreactance (21/40)		V
Volts-per-hertz overexcitation (24)		V
Programmable stage (99)		•
Voltage memory		•
Arc protection (50Arc/50Narc) (optional)		•
Control		
Objects to control and monitor (OBJ): 10		•
Single-pole object control and monitoring (OBJ5)		V
Indicator objects to monitor (IND): 10		•
Setting groups (SGS): 8		•
Cold load pick-up (CLPU)		•
Switch-on-to-fault (SOTF)		•
Automatic voltage regulator (90)		V
Auto-recloser (79)		•
Zero sequence recloser (79N)		•
Vector jump (78)		•
Synchrocheck (25)		•
Synchronizer (25)		S
Monitoring		
Current transformer supervision (CTS)		•
Voltage transformer supervision (VTS; 60)		•
Circuit breaker wear monitoring (CBW)		•
Current total harmonic distortion (THD)		•
Voltage total harmonic distortion (THD)		•
Fault locator (21FL)		•
Disturbance records: 100 (à 5 s 3.2 kHz sampling)		•
Non-volatile event records: 15,000		•
Measurements		
Phase, sequence, and residual currents ($I_A, I_B, I_C, I_{D1}, I_{D2}$)		•
Phase, sequence, and residual voltages ($V_A, V_B, V_C, V_{AB}, V_{BC}, V_{CA}, V_D$)		•
Frequency (f)		•
Power (P, Q, S, cos φ) and energy (E+, E-, Eq+, Eq-)		•
Power and energy measurement accuracy 0.5		•
Power and energy measurement accuracy 0.2 % (optional)		•
Hardware		
Standard features	Digital inputs: 3	•
	Digital outputs: 5	•
	Current inputs: 5	•
	Voltage inputs: 4	•
Optional modules	Empty module slots: 11	•
	Digital input module: 8 inputs	•
	Digital output module: 5 outputs	•
	Milliampere I/O module: 4 outputs + 1 input	•
Communication	Arc protection module: 4 sensors + 2 HSO + 1 BI	•
	External I/O modules (see the "Accessories" page)	•
Comm. inputs	1 port with RJ-45 Ethernet 100 MB (front)	•
	1 port with RJ-45 Ethernet 100 MB (rear, COM A)	•
	1 port with RS-485 (rear, COM B)	•
Optional modules	2 × RJ-45 Ethernet (100 MB/s) + IRIG-B input	•
	2 × 5T Ethernet (100 MB/s) + IRIG-B input	•
	2 × LC Ethernet (100 MB/s, PRP/HSR)	•
Communication protocols	RS-232 serial fiber (PP/PG/GP/PP)	•
	IEC 61850 (1st Edition)	•
	IEC 61850 (2nd Edition)	•
	IEC 60870-5-101/104	•
	IEC 60870-5-103	•
	Modbus/RTU and Modbus/TCP	•
DNP3	•	
SPA	•	

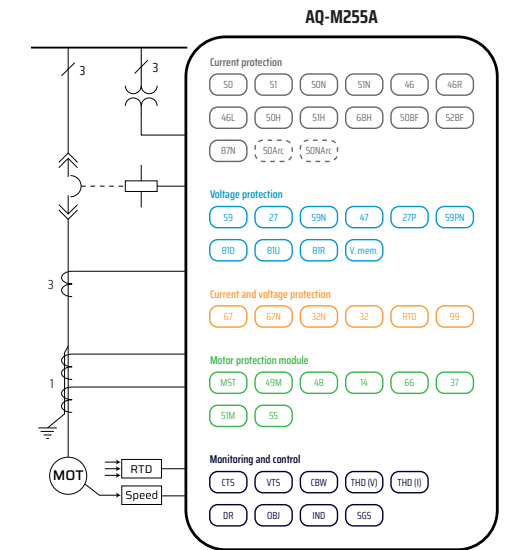

AQ-M255 Motor protection device



The AQ-M255 motor protection device offers a modular protection and control solution for larger and more important motors that require a large I/O capacity. You can add up to total 11 option modules (I/O and other type of modules) into the device for extensive monitoring and control applications. You can also connect up to 16 RTD signals for thermal alarming and tripping. AQ-M255 communicates using various protocols, including the IEC 61850.

- HIGHLIGHTS:**
- Powerful motor management with a large I/O capacity.
 - 5 thermal models (time constant accurate).
 - Soft start protection begins at 6 Hz.
 - Wye-delta started motor supervision.
 - Two-speed motor protection.
 - Optional power and energy measurement accuracy of 0.2 %.
 - Asynchronous and synchronous motors.
 - Includes IEC 61850 2nd Edition.

PROTECTION:

- Non-directional overcurrent (50/51)
- Non-directional ground fault (50N/51N)
- Directional overcurrent (67)
- Directional ground fault (67N/32N)
- Negative sequence overcurrent / Phase current reversal / Current unbalance (46/46R/46L)
- Harmonic overcurrent (50H/51H/68H)
- Circuit breaker failure protection (50BF/52BF)
- High- and low-impedance restricted ground fault / Cable-end differential (87N)
- Overvoltage (59)
- Undervoltage (27)
- Neutral overvoltage (59N)
- Sequence voltage (47/27P/59PN)
- Over- and underfrequency (810/81U)
- Rate-of-change of frequency (81R)
- Power protection (32)
- Resistance temperature detectors (RTD)
- Motor status monitoring (MST)
- Machine thermal overload (49M)
- Motor start / Locked rotor monitoring (48/14)
- Frequent start (66)
- Non-directional undercurrent (37)
- Mechanical jam (51M)
- Power factor protection (55)
- Programmable stage (99)
- Arc protection (50Arc/50Narc) (optional)
- Voltage memory

CONTROL:

- Objects to control and monitor (OBJ): 10
- Indicator objects to monitor (IND): 10
- Setting groups (SGS): 8

MONITORING:

- Current transformer supervision (CTS)
- Voltage transformer supervision (VTS; 60)
- Circuit breaker wear monitoring (CBW)
- Current total harmonic distortion (THD)
- Voltage total harmonic distortion (THD)
- Disturbance records: 100 (à 5 s 3.2 kHz sampling)
- Non-volatile event records: 15,000

MEASUREMENTS:

- Phase, sequence, and residual currents ($I_A, I_B, I_C, I_{D1}, I_{D2}$)
- Phase, sequence, and residual voltages ($V_A, V_B, V_C, V_{AB}, V_{BC}, V_{CA}, V_D$)
- Frequency (f)
- Power (P, Q, S, cos φ) and energy (E+, E-, Eq+, Eq-)
- Power and energy measurement accuracy 0.5
- Power and energy measurement accuracy 0.2 % (optional)

HARDWARE:

- **Standard features:**
 - Digital inputs: 3
 - Output relays: 5
 - Current inputs: 5
 - Voltage inputs: 4
 - Empty module slots: 11

Optional hardware modules:

- Digital input module: 8 inputs
- Digital output module: 5 outputs
- Milliampere I/O module: 4 outputs + 1 input
- Arc protection module: 4 sensors + 2 HSO + 1 BI
- External I/O modules (see the "Accessories" page)

COMMUNICATION:

- **Standard inputs:**
 - 1 port with RJ-45 Ethernet 100 MB (front)
 - 1 port with RJ-45 Ethernet 100 MB (rear, COM A)
 - 1 port with RS-485 (rear, COM B)
- **Optional modules:**
 - 2 × RJ-45 Ethernet (100 MB/s) + IRIG-B input
 - 2 × 5T Ethernet (100 MB/s) + IRIG-B input
 - 2 × LC Ethernet (100 MB/s, PRP/HSR)
 - RS-232 serial fiber (PP/PG/GP/PP)
- **Protocols:**
 - IEC 61850 (1st Edition)
 - IEC 61850 (2nd Edition)
 - IEC 60870-5-101/104
 - IEC 60870-5-103
 - Modbus/RTU and Modbus/TCP
 - DNP3
 - SPA

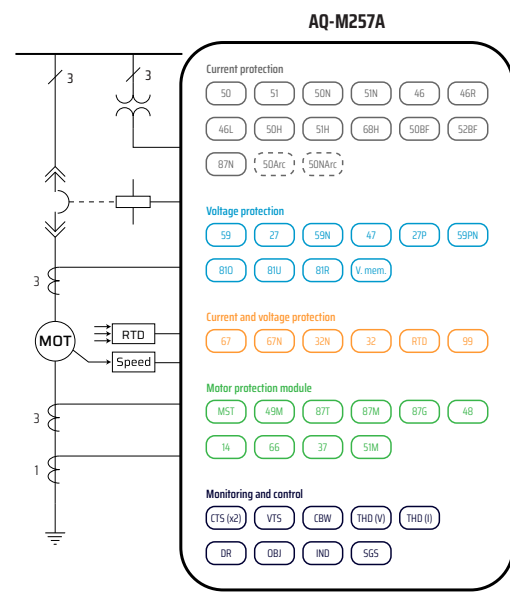

AQ-M257 Motor protection device



READ MORE

The AQ-M257 offers a modular motor protection and control solution for large and important asynchronous or synchronous motors requiring differential protection. Up to 9 optional I/O or communication cards are available for extensive monitoring and control applications. Up to 16 RTD signals can be connected for thermal alarming and tripping. The AQ-M257 communicates using various protocols including IEC 61850 substation communication standard.

HIGHLIGHTS:

- Differential protection.
- A large I/O capacity.
- 5 thermal models (time constant accurate).
- Soft-start protection beginning from 6 Hz.
- Wye-delta started motor supervision.
- Two-speed motor protection.
- Optional power and energy measurement accuracy of up to 0.2 %.
- Asynchronous and synchronous motors.

SOFTWARE OPTIONS:

- AQ-M257A - Asynchronous motor protections
- AQ-M257B - Synchronous motor protections

PROTECTION:

- Non-directional overcurrent (50/51)
- Non-directional ground fault (50N/51N)
- Directional overcurrent (67)
- Directional ground fault (67N/32N)
- Negative sequence overcurrent / Phase current reversal / Current unbalance (46/46R/46L)
- Harmonic overcurrent (50H/51H/68H)
- Circuit breaker failure protection (50BF/52BF)
- High- and low-impedance restricted ground fault / Cable-end differential (87N)
- Overvoltage (59)
- Undervoltage (27)
- Neutral overvoltage (59N)
- Sequence voltage (47/27P/59PN) (AQ-M257A only)
- Over- and underfrequency (810/81U)
- Rate-of-change of frequency (81R)
- Power protection (32)
- Pole slip / Out-of-step protection (78)
- Resistance temperature detectors (RTD)
- Motor status monitoring (MST)
- Machine thermal overload (49M)
- Generator/transformer differential (87T/87M/87G)
- Power factor protection (55)
- Motor start / Locked rotor monitoring (48/14)
- Frequent start (66)
- Non-directional undercurrent (37)
- Mechanical jam (51M)
- Underexcitation (40) (AQ-M257B only)
- Programmable stage (99)

- Arc protection (50Arc/50Narc) (optional)
- Voltage memory

CONTROL:

- Objects to control and monitor (OBJ): 10
- Indicator objects to monitor (IND): 10
- Setting groups (SGS): 8

MONITORING:

- 2 x Current transformer supervision (CTS)
- Voltage transformer supervision (60)
- Circuit breaker wear monitoring (CBW)
- Current total harmonic distortion (THD)
- Voltage total harmonic distortion (THD)
- Disturbance records: 100 (à 5 s 3.2 kHz sampling)
- Non-volatile event records: 15,000

MEASUREMENTS:

- Phase, sequence, and residual currents ($I_A, I_B, I_C, I_{01}, I_{02}$)
- Phase, sequence, and residual voltages ($V_A, V_B, V_C, V_{BC}, V_{CA}, V_{CB}$)
- Frequency (f)
- Power (P, Q, S, cos φ) and energy (E+, E-, Eq+, Eq-)
- Power and energy measurement accuracy 0.5
- Power and energy measurement accuracy 0.2% (optional)

HARDWARE:

- **Standard features:**
 - Digital inputs: 3
 - Output relays: 5

- Current inputs: 5
- Voltage inputs: 4
- Empty module slots: 11
- **Optional hardware modules:**
 - Digital input module: 8 inputs
 - Digital output module: 5 outputs
 - Milliampere I/O module: 4 outputs + 1 input
 - Arc protection module: 4 sensors + 2 HSO + 1 BI
 - External I/O modules (see the "Accessories" page)

COMMUNICATION:

- **Standard inputs:**
 - 1 port with RJ-45 Ethernet 100 MB (front)
 - 1 port with RJ-45 Ethernet 100 MB (rear, COM A)
 - 1 port with RS-485 (rear, COM B)
- **Optional modules:**
 - 2 x RJ-45 Ethernet (100 MB/s) + IRIG-B input
 - 2 x ST Ethernet (100 MB/s) + IRIG-B input
 - 2 x LC Ethernet (100 MB/s, PRP/HSR)
 - RS-232 serial fiber (PP/PG/GP/PP)
- **Protocols:**
 - IEC 61850 (1st Edition)
 - IEC 61850 (2nd Edition)
 - IEC 60870-5-101/104
 - IEC 60870-5-103
 - Modbus/RTU and Modbus/TCP
 - DNP3
 - SPA

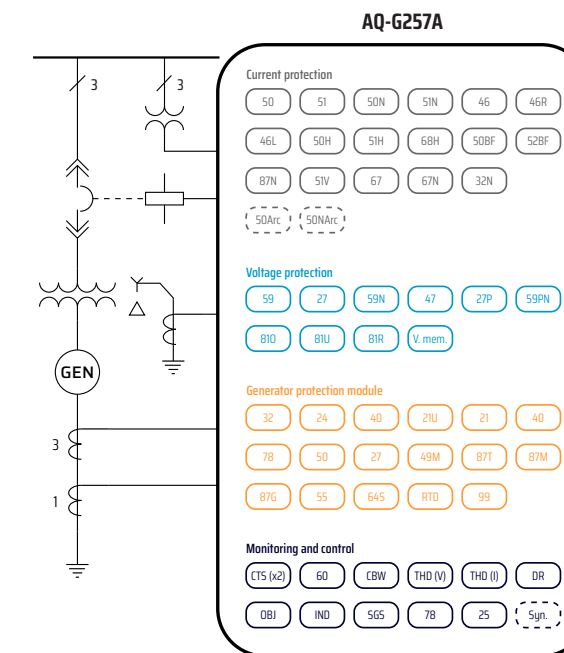

AQ-G257 Generator protection device



READ MORE

The AQ-G257 generator protection device is well-suited for large machines that require complete generator protection and differential protection. The device has an integrated automatic voltage regulator function. You can add up to total 9 option modules (I/O and other type of modules) into the device for extensive monitoring and control applications. You can also connect up to 16

RTD signals for thermal alarming and tripping. AQ-G257 communicates using various protocols, including the IEC 61850.

SOFTWARE OPTIONS:

- AQ-G257A - standard generator protections
- AQ-G257B - standard generator protections + synchronizer

PROTECTION:

- Non-directional overcurrent (50/51)
- Non-directional ground fault (50N/51N)
- Directional overcurrent (67)
- Directional ground fault (67N/32N)
- Negative sequence overcurrent / Phase current reversal / Current unbalance (46/46R/46L)
- Harmonic overcurrent (50H/51H/68H)
- Circuit breaker failure protection (50BF/52BF)
- High- and low-impedance restricted ground fault / Cable-end differential (87N)
- Voltage-restrained overcurrent (51V)
- Overvoltage (59)
- Undervoltage (27)
- Neutral overvoltage (59N)
- Sequence voltage (47/27P/59PN)
- Over- and underfrequency (810/81U)
- Rate-of-change of frequency (81R)
- Power protection (32)
- Volts-per-hertz overexcitation (24)
- Underexcitation (40)
- Underimpedance (21U)
- Underreactance (21/40)
- Resistance temperature detectors (RTD)
- Machine thermal overload (49M)
- Transformer/motor/generator differential (87T/87M/87G)
- Power factor protection (55)
- 100 % stator ground fault (64S)
- Programmable stage (99)
- Arc protection (50Arc/50Narc) (optional)
- Voltage memory

CONTROL:

- Objects to control and monitor (OBJ): 10
- Indicator objects to monitor (IND): 10
- Setting groups (SGS): 8
- Vector jump (78)
- Voltage inputs: 4
- Synchronizer (25) (AQ-G257B only)

MONITORING:

- Current transformer supervision (CTS) (2 instances)
- Voltage transformer supervision (VTS); 60)
- Circuit breaker wear monitoring (CBW)
- Current total harmonic distortion (THD)
- Voltage total harmonic distortion (THD)
- Disturbance records: 100 (à 5 s 3.2 kHz sampling)
- Non-volatile event records: 15,000

MEASUREMENTS:

- Phase, sequence, and residual currents ($I_A, I_B, I_C, I_{01}, I_{02}$)
- Phase, sequence, and residual voltages ($V_A, V_B, V_C, V_{BC}, V_{CA}, V_{CB}$)
- Frequency (f)
- Power (P, Q, S, cos φ) and energy (E+, E-, Eq+, Eq-)
- Power and energy measurement accuracy 0.5
- Power and energy measurement accuracy 0.2% (optional)

HARDWARE:

- **Standard features:**
 - Digital inputs: 3
 - Output relays: 5
 - Current inputs: 10
 - Voltage inputs: 4
 - Empty module slots: 9
- **Optional hardware modules:**
 - Digital input module: 8 inputs
 - Digital output module: 5 outputs
 - Milliampere I/O module: 4 outputs + 1 input
 - Arc protection module: 4 sensors + 2 HSO + 1 BI
 - External I/O modules (see the "Accessories" page)
- **COMMUNICATION:**
 - **Standard inputs:**
 - 1 port with RJ-45 Ethernet 100 MB (front)
 - 1 port with RJ-45 Ethernet 100 MB (rear, COM A)
 - 1 port with RS-485 (rear, COM B)
 - **Optional modules:**
 - 2 x RJ-45 Ethernet (100 MB/s) + IRIG-B input
 - 2 x ST Ethernet (100 MB/s) + IRIG-B input
 - 2 x LC Ethernet (100 MB/s, PRP/HSR)
 - RS-232 serial fiber (PP/PG/GP/PP)
 - **Protocols:**
 - IEC 61850 (1st Edition)
 - IEC 61850 (2nd Edition)
 - IEC 60870-5-101/104
 - IEC 60870-5-103
 - Modbus/RTU and Modbus/TCP
 - DNP3
 - SPA

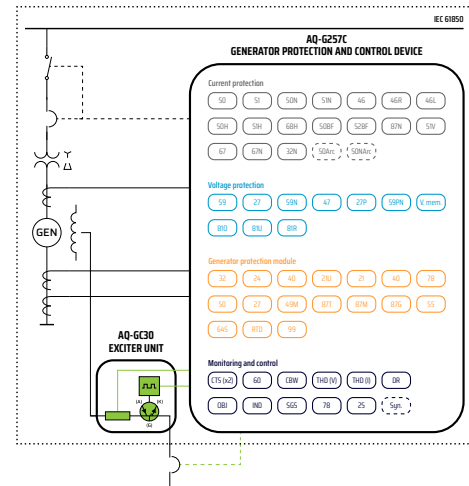

The Generator Commander

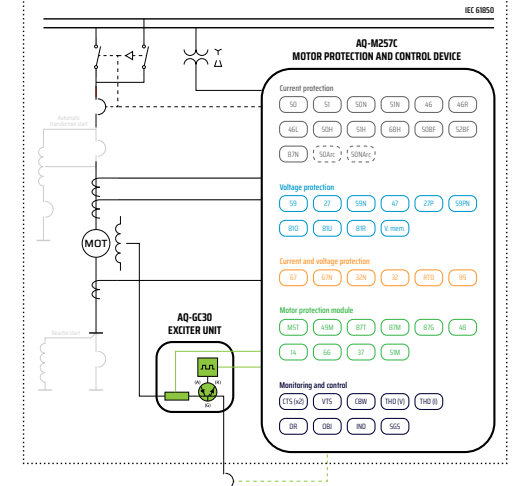

The Motor Commander



READ MORE

Synchronous generator control and protection in one package! The Generator Commander is an innovation that combines synchronous generator protection and control into a single device. The Commander is ideal for any power plant or industrial application where both protection and control of generators needed. Compared to traditional systems with several separate devices and multiple software, the GeneratorCommander takes less space and saves considerable hours of engineering time. Additionally, its operation is smooth as there is only one interface.

FEATURES:

- Generator and differential protection.
- Synchronizer with synchrocheck.
- Excitation control with an external IGBT bridge.
- Power and energy measurement (0.2 % accuracy).
- Sophisticated network compensation.
- Power System Stabilizer (PSS).

SOFTWARE OPTIONS:

- AQ-G257C - standard generator protection functionality + excitation control
- AQ-G257D - standard generator protection functionality + excitation control + power system stabilizer
- AQ-G257E - standard generator protection functionality + excitation control + synchronizer
- AQ-G257F - standard generator protection functionality + excitation control + power system stabilizer + synchronizer

GENERATOR PROTECTION FUNCTIONS:

- Non-directional overcurrent (50/51)
- Non-directional ground fault (50N/51N)
- Directional overcurrent (67)
- Directional ground fault (67N/32N)
- Negative sequence overcurrent / Phase current reversal / Current unbalance (46/46R/46L)
- Harmonic overcurrent (50H/51H/68H)
- Circuit breaker failure protection (50BF/52BF)
- High- and low-impedance restricted ground fault / Cable-end differential (87N)
- Voltage-restrained overcurrent (51V)
- Overvoltage (59)
- Undervoltage (27)
- Neutral overvoltage (59N)
- Sequence voltage (47/27P/59PN)
- Over- and underfrequency (810/81U)
- Rate-of-change of frequency (81R)
- Power protection (32)
- Volts-per-hertz overexcitation (24)
- Underexcitation (40)
- Underimpedance (21U)
- Underreactance (21/40)
- Pole slip (78)
- Resistance temperature detectors (RTD)
- Machine thermal overload (49M)
- Transformer/motor/generator differential (87T/87M/87G)
- Power factor protection (55)
- 100 % stator ground fault (64S)

- Programmable stage (99)
- Arc protection (50Arc/50Narc) (optional)
- Voltage memory

CONTROL:

- Objects to control and monitor (OBJ): 10
- Indicator objects to monitor (IND): 10
- Setting groups (SGS): 8
- Vector jump (78)
- Synchrocheck (25)
- Synchronizer (25) (optional)
- Excitation with an external IGBT bridge
- Power system stabilizer PSS

MONITORING:

- Current transformer supervision (CTS) (2 instances)
- Voltage transformer supervision (VTS; 60)
- Circuit breaker wear monitoring (CBW)
- Current total harmonic distortion (THD)
- Voltage total harmonic distortion (THD)
- Disturbance records: 100 (à 5 s 3.2 kHz sampling)
- Non-volatile event records: 15,000

MEASUREMENTS:

- Phase, sequence, and residual currents ($I_A, I_B, I_C, I_{01}, I_{02}$)
- Phase, sequence, and residual voltages ($V_A, V_B, V_C, V_{BC}, V_{CA}, V_{AB}$)
- Frequency (f)
- Power (P, Q, S, cos φ) and energy (E+, E-, Eq+, Eq-)
- Power and energy measurement accuracy 0.5
- Power and energy measurement accuracy 0.2 % (optional)

HARDWARE:

- **Standard features:**
 - Digital inputs: 3
 - Output relays: 5
 - Current inputs: 10
 - Voltage inputs: 4
 - Empty module slots: 9
- **Optional hardware modules:**
 - Digital input module: 8 inputs
 - Digital output module: 5 outputs
 - Milliampere I/O module: 4 outputs + 1 input
 - Arc protection module: 4 sensors + 2 HSO + 1 BI
 - External I/O modules (see the "Accessories" page)

COMMUNICATION:

- **Standard inputs:**
 - 1 port with RJ-45 Ethernet 100 MB (front)
 - 1 port with RJ-45 Ethernet 100 MB (rear, COM A)
 - 1 port with RS-485 (rear, COM B)
- **Optional modules:**
 - 2 × RJ-45 Ethernet (100 MB/s) + IRIG-B input
 - 2 × ST Ethernet (100 MB/s) + IRIG-B input
 - 2 × LC Ethernet (100 MB/s, PRP/HSR)
 - RS-232 serial fiber (PP/PG/GP/PP)
- **Protocols:**
 - IEC 61850 (1st Edition)
 - IEC 61850 (2nd Edition)
 - IEC 60870-5-101/104
 - IEC 60870-5-103
 - Modbus/RTU and Modbus/TCP
 - DNP3
 - SPA



READ MORE

Synchronous motor control and protection in one package! The Motor Commander is an innovation that combines synchronous motor protection and control into a single device. The Commander is ideal for any power plant or industrial application where both protection and control of generators needed. Compared to traditional systems with several separate devices and multiple software, the Motor Commander takes less space and saves considerable hours of engineering time. Additionally, its operation is smooth as there is only one interface.

FEATURES:

- Motor and differential protection.
- Start-up sequence control.
- Excitation with an external IGBT bridge.
- Power and energy measurement (0.2 %).
- Sophisticated network compensation.
- Power System Stabilizer (PSS).

MOTOR PROTECTION FUNCTIONS:

- Non-directional overcurrent (50/51)
- Non-directional ground fault (50N/51N)
- Directional overcurrent (67)
- Directional ground fault (67N/32N)
- Negative sequence overcurrent / Phase current reversal / Current unbalance (46/46R/46L)
- Harmonic overcurrent (50H/51H/68H)
- Circuit breaker failure protection (50BF/52BF)
- High- and low-impedance restricted ground fault / Cable-end differential (87N)
- Overvoltage (59)
- Undervoltage (27)
- Neutral overvoltage (59N)
- Sequence voltage (47/27P/59PN)
- Over- and underfrequency (810/81U)
- Rate-of-change of frequency (81R)
- Power protection (32)
- Volts-per-hertz overexcitation (24)
- Underexcitation (40)
- Underimpedance (21U)
- Underreactance (21/40)
- Pole slip (78)
- Resistance temperature detectors (RTD)
- Motor status monitoring (MST)
- Machine thermal overload (49M)
- Transformer/motor/generator differential (87T/87M/87G)
- Motor start / Locked rotor monitoring (48/14)
- Frequent start (66)
- Non-directional undercurrent (37)
- Mechanical jam (51M)
- Programmable stage (99)

- Arc protection (50Arc/50Narc) (optional)
- Voltage memory

CONTROL:

- Objects to control and monitor (OBJ): 10
- Indicator objects to monitor (IND): 10
- Setting groups (SGS): 8
- Vector jump (78)
- Synchrocheck (25)
- Synchronizer (25) (optional)
- Excitation with an external IGBT bridge
- Power system stabilizer PSS

MONITORING:

- Current transformer supervision (CTS) (2 instances)
- Voltage transformer supervision (VTS; 60)
- Circuit breaker wear monitoring (CBW)
- Current total harmonic distortion (THD)
- Voltage total harmonic distortion (THD)
- Disturbance records: 100 (à 5 s 3.2 kHz sampling)
- Non-volatile event records: 15,000

MEASUREMENTS:

- Phase, sequence, and residual currents ($I_A, I_B, I_C, I_{01}, I_{02}$)
- Phase, sequence, and residual voltages ($V_A, V_B, V_C, V_{BC}, V_{CA}, V_{AB}$)
- Frequency (f)
- Power (P, Q, S, cos φ) and energy (E+, E-, Eq+, Eq-)
- Power and energy measurement accuracy 0.5
- Power and energy measurement accuracy 0.2 % (optional)

HARDWARE:

- **Standard features:**
 - Digital inputs: 3
 - Output relays: 5
 - Current inputs: 10
 - Voltage inputs: 4
 - Empty module slots: 9
- **Optional hardware modules:**
 - Digital input module: 8 inputs
 - Digital output module: 5 outputs
 - Milliampere I/O module: 4 outputs + 1 input
 - Arc protection module: 4 sensors + 2 HSO + 1 BI
 - External I/O modules (see the "Accessories" page)

COMMUNICATION:

- **Standard inputs:**
 - 1 port with RJ-45 Ethernet 100 MB (front)
 - 1 port with RJ-45 Ethernet 100 MB (rear, COM A)
 - 1 port with RS-485 (rear, COM B)
- **Optional modules:**
 - 2 × RJ-45 Ethernet (100 MB/s) + IRIG-B input
 - 2 × ST Ethernet (100 MB/s) + IRIG-B input
 - 2 × LC Ethernet (100 MB/s, PRP/HSR)
 - RS-232 serial fiber (PP/PG/GP/PP)
- **Protocols:**
 - IEC 61850 (1st Edition)
 - IEC 61850 (2nd Edition)
 - IEC 60870-5-101/104
 - IEC 60870-5-103
 - Modbus/RTU and Modbus/TCP
 - DNP3
 - SPA

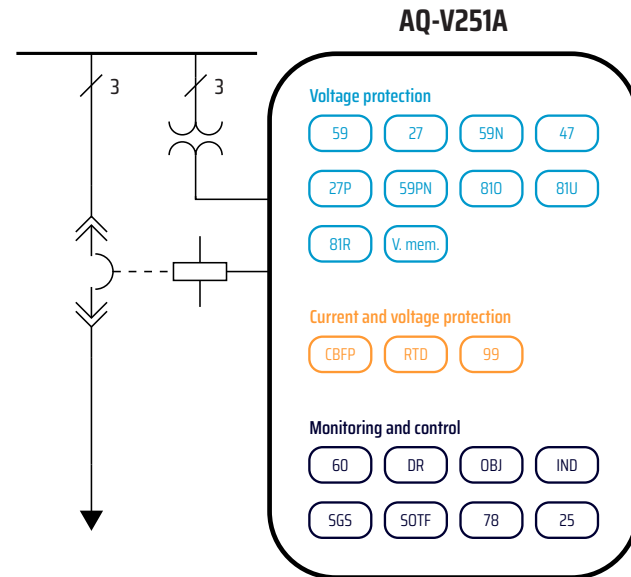

AQ-V251 Voltage protection device



READ MORE

The AQ-V251 voltage protection device offers a modular voltage protection solution for substations. The relay includes both voltage and frequency protections as well as powerful logic programming, and you can add up to total 11 option modules (I/O and other type of modules). The V251 is suitable for demanding load shedding applications and includes synchronizer functionality as software option. AQ-V251 voltage protection device communicates using various protocols, including the IEC 61850.

HIGHLIGHTS:

- A large I/O capacity.
- 8 frequency stages and 8 setting groups for load shedding.
- Synchrocheck for up to 3 circuit breakers.
- Anti-islanding protection.
- Includes IEC 61850 2nd Edition.

SOFTWARE OPTIONS:

- AQ-V251A - standard voltage protection functionality
- AQ-V251B - standard voltage protection functionality + synchronizer

PROTECTION:

- Circuit breaker failure protection (50BF/52BF)
- Overvoltage (59)
- Undervoltage (27)
- Neutral overvoltage (59N)
- Sequence voltage (47/27P/59PN)
- Over- and underfrequency (810/81U)
- Rate-of-change of frequency (81R)
- Resistance temperature detectors (RTD)
- Programmable stage (99)
- Voltage memory

CONTROL:

- Objects to control and monitor (OBJ): 5
- Indicator objects to monitor (IND): 5
- Setting groups (SGS): 8
- Switch-on-to-fault (SOTF)
- Vector jump (78)
- Synchrocheck (Δ25)
- Synchronizer (25) (AQ-V251B only)

MONITORING:

- Voltage transformer supervision (60)
- Disturbance records: 100 (à 5 s 3.2 kHz sampling)
- Non-volatile event records: 15,000

MEASUREMENTS:

- Phase, sequence, and residual voltages ($V_A, V_B, V_C, V_{AB}, V_{BC}, V_{CA}, V_D$)

HARDWARE:

- **Standard features:**
 - Digital inputs: 3
 - Output relays: 5
 - Voltage inputs: 4
 - Empty module slots: 11
- **Optional hardware modules:**
 - Digital input module: 8 inputs
 - Digital output module: 5 outputs
 - Milliampere I/O module: 4 outputs + 1 input
 - Arc protection module: 4 sensors + 2 HSO + 1 BI
 - External I/O modules (see the "Accessories" page)

COMMUNICATION:

- **Standard inputs:**
 - 1 port with RJ-45 Ethernet 100 MB (front)
 - 1 port with RJ-45 Ethernet 100 MB (rear, COM A)
 - 1 port with RS-485 (rear, COM B)
- **Optional modules:**
 - 2 × RJ-45 Ethernet (100 MB/s) + IRIG-B input
 - 2 × ST Ethernet (100 MB/s) + IRIG-B input
 - 2 × LC Ethernet (100 MB/s, PRP/HSR)
 - RS-232 serial fiber (PP/PG/GP/PP)
- **Protocols:**
 - IEC 61850 (1st Edition)
 - IEC 61850 (2nd Edition)
 - IEC 60870-5-101/104
 - IEC 60870-5-103
 - Modbus/RTU and Modbus/TCP
 - DNP3
 - SPA

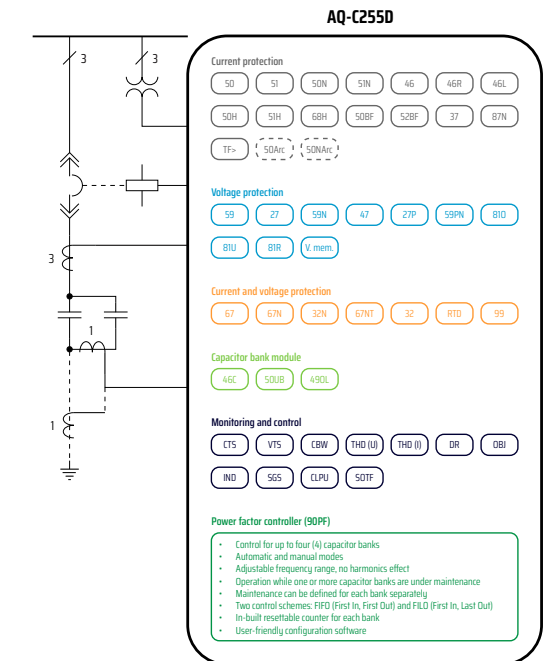

AQ-C255 Capacitor bank protection device



READ MORE

The AQ-C255 capacitor bank protection device has been specifically designed for the protection of capacitor banks. It includes capacitor bank current unbalance, capacitor bank neutral unbalance, and overload protections in addition to the standard overcurrent, ground fault and voltage protections. AQ-C255 offers a modular protection and control solution for applications that require a large I/O capacity. You can add up to total 11 option modules (I/O and other type of modules) into the device for extensive monitoring and control applications. The AQ-C255 capacitor bank protection device communicates using various protocols, including the IEC 61850.

HIGHLIGHTS:

- A large I/O capacity.
- Double busbar control.
- Capacitor bank module with capacitor-specific protection functions.
- The new power factor controller function (up to 5 capacitor banks).
- Optional power and energy measurement accuracy of 0.2 %.
- Includes IEC 61850 2nd Edition.

SOFTWARE OPTIONS:

- AQ-C255A - standard capacitor bank functionality
- AQ-C255B - PFC (up to 5 capacitor banks)
- AQ-C255C - standard voltage protections + PFC (up to 5 capacitor banks)
- AQ-C255D - standard capacitor bank functionality + PFC (up to 4 capacitor banks)

Protection	AQ-C255A, -B, C, D, E
Non-directional overcurrent (50/51)	A, D, E
Non-directional ground fault (50N/51N)	A, D, E
Directional overcurrent (67)	A, D, E
Directional ground fault (67N/32N)	A, D, E
Intermittent ground fault (67NT)	A, D, E
Negative sequence overcurrent / Phase current reversal / Current unbalance (46/46R/46L)	A, D, E
Harmonic overcurrent (50H/51H/68H)	A, D, E
Circuit breaker failure protection (50BF/52BF)	A, C, D, E
High- and low-impedance restricted ground fault / Cable-end differential (87N)	A, D, E
Capacitor bank overload protection (49OL)	A, D, E
Capacitor bank neutral unbalance protection (50UB)	A, D, E

Protection		AQ-C255A, -B, C, D, E
Capacitor bank current unbalance protection (46C)		A, D, E
Non-directional undercurrent protection (37)		A, D, E
Overvoltage (59)		A, C, D, E
Undervoltage (27)		A, C, D, E
Neutral overvoltage (59N)		A, C, D, E
Sequence voltage (47/27P/59PN)		A, C, D, E
Over- and underfrequency (810/81U)		A, C, D, E
Rate-of-change of frequency (81R)		A, C, D, E
Power protection (32)		A, C, D, E
Overpower protection (32O)		A, C, D, E
Underpower protection (32U)		A, C, D
Reverse power (32R)		C
Line thermal overload (49F)		A, D
Resistance temperature detectors (RTD)		A, C, D
Programmable stage (99)		A, D
Voltage memory		A, B, C, D
Arc protection (50Arc/50Narc) (optional)		A, B
Control		
Objects to control and monitor (OBJ): 10		•
Indicator objects to monitor (IND): 10		•
Cold load pick-up (CLPU)		•
Switch-on-to-fault (SOTF)		•
Monitoring		
Current transformer supervision (CTS)		A, C, D, E
Voltage transformer supervision (VTS; 60)		•
Circuit breaker wear monitoring (CBW)		A, C, D, E
Current total harmonic distortion (THD)		A, C, D, E
Voltage total harmonic distortion (THD)		A, C, D, E
Fault locator (21FL)		A, C, D, E
Disturbance records: max 100 records		•
Non-volatile event records: max 15,000 records		•
Measurements		
Phase, sequence, and residual currents ($I_A, I_B, I_C, I_{D1}, I_{D2}$)		A, C, D, E
Phase, sequence, and residual voltages ($V_A, V_B, V_C, V_{AB}, V_{BC}, V_{CA}, V_D$)		•
Frequency (f)		•
Power (P, Q, S, cos φ) and energy (E+, E-, Eq+, Eq-)		•
Power and energy measurement accuracy 0.5		A, B, C, D
Power and energy measurement accuracy 0.2% (optional)		A, B, C, D
Hardware		
Standard features	Digital inputs: 3 Digital outputs: 5 Current inputs: 5 Voltage inputs: 4 Empty module slots: 11	• • A, C, D, E • •
Optional modules	Additional digital input module: 8...88 inputs Additional digital output module: 5...30 outputs Milliampere I/O module: 4 outputs + 1 input Arc protection module: 4 sensors + 2 HSO + 1 BI External I/O modules (see the "Accessories" page)	• • • • •
Communication		
Comm. inputs	1 port with RJ-45 Ethernet 100 MB (front) 1 port with RJ-45 Ethernet 100 MB (rear, COM A) 1 port with RS-485 (rear, COM B)	• • •
Optional modules	2 × RJ-45 Ethernet (100 MB/s) + IRIG-B input 2 × ST Ethernet (100 MB/s) + IRIG-B input 2 × LC Ethernet (100 MB/s, PRP/HSR) RS-232 serial fiber (PP/PG/GP/PP)	• • • •
Communication protocols	IEC 61850 (1st Edition) IEC 61850 (2nd Edition) IEC 60870-5-101/104 IEC 60870-5-103 Modbus/RTU and Modbus/TCP DNP3 SPA	• • • • • • •

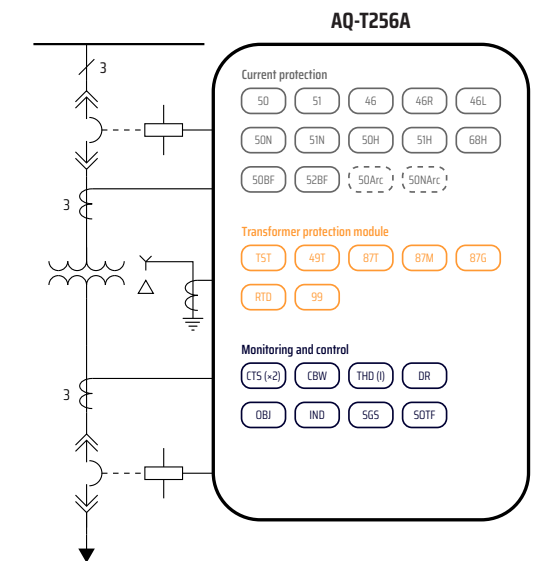

AQ-T256 Transformer protection device

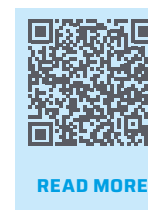

READ MORE

AQ-T256 is a transformer protection device with sophisticated and easy-to-use differential protection functions. The relay provides overcurrent protection for both low-voltage and high-voltage sides, ground fault protection, negative sequence overcurrent protection as well as two independent instances of restricted ground fault protection. You can add up to total 11 option modules (I/O and other type of modules) into the device for extensive monitoring and control applications. AQ-T256 is a transformer protection device with a sophisticated and easy-to-use differential protection function. communicates using various protocols, including the IEC 61850.

HIGHLIGHTS:

- A large I/O capacity.
- Both predefined and customizable connection group selection.
- 2nd and 5th harmonic blocking.
- Automatic verification of connection group and nominal value settings.
- Overloading and through fault statistics for preventative maintenance.
- Includes IEC 61850 2nd Edition.

PROTECTION:

- Non-directional overcurrent (50/51)
- Non-directional ground fault (50N/51N)
- Negative sequence overcurrent / Phase current reversal / Current unbalance (46/46R/46L)
- Harmonic overcurrent (50H/51H/68H)
- Circuit breaker failure protection (50BF/52BF)
- Resistance temperature detectors (RTD)
- Transformer status monitoring (TRF)
- Transformer thermal overload (49T)
- Transformer/motor/generator differential (87T/87M/87G)
- Programmable stage (99)
- Arc protection (50Arc/50Narc) (optional)

CONTROL:

- Objects to control and monitor (OBJ): 10
- Indicator objects to monitor (IND): 10
- Setting groups (SGS): 8
- Switch-on-to-fault (SOTF)

MONITORING:

- Current transformer supervision (CTS) (2 instances)
- Circuit breaker wear monitoring (CBW)
- Current total harmonic distortion (THD)
- Disturbance records: 100 (à 5 s 3.2 kHz sampling)

- Non-volatile event records: 15,000

MEASUREMENTS:

- Phase, sequence, and residual voltages ($V_A, V_B, V_C, V_{AB}, V_{BC}, V_{CA}, V_D$)

HARDWARE:

- **Standard features:**
 - Digital inputs: 3
 - Output relays: 5
 - Current inputs: 10
 - Empty module slots: 10
- **Optional hardware modules:**
 - Digital input module: 8 inputs
 - Digital output module: 5 outputs
 - Milliampere I/O module: 4 outputs + 1 input
 - Arc protection module: 4 sensors + 2 HSO + 1 BI
 - External I/O modules (see the "Accessories" page)

COMMUNICATION:

- **Standard inputs:**
 - 1 port with RJ-45 Ethernet 100 MB (front)
 - 1 port with RJ-45 Ethernet 100 MB (rear, COM A)
 - 1 port with RS-485 (rear, COM B)

Optional modules:

- 2 × RJ-45 Ethernet (100 MB/s) + IRIG-B input
- 2 × ST Ethernet (100 MB/s) + IRIG-B input
- 2 × LC Ethernet (100 MB/s, PRP/HSR)
- RS-232 serial fiber (PP/PG/GP/PP)

Protocols:

- IEC 61850 (1st Edition)
- IEC 61850 (2nd Edition)
- IEC 60870-5-101/104
- IEC 60870-5-103
- Modbus/RTU and Modbus/TCP
- DNP3
- SPA

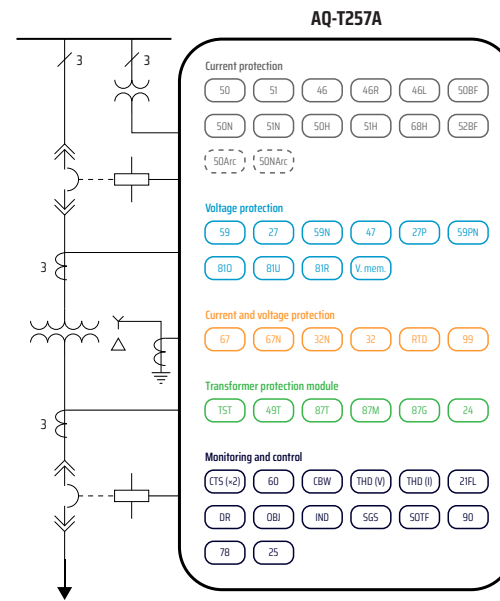

PROTECTION:

- Non-directional overcurrent (50/51)
- Non-directional ground fault (50N/51N)
- Directional overcurrent (67)
- Directional ground fault (67N/32N)
- Negative sequence overcurrent / Phase current reversal / Current unbalance (46/46R/46L)
- Harmonic overcurrent (50H/51H/68H)
- Circuit breaker failure protection (50BF/52BF)
- Overvoltage (59)
- Undervoltage (27)
- Neutral overvoltage (59N)
- Sequence voltage (47/27P/59PN)
- Over- and underfrequency (810/81U)
- Rate-of-change of frequency (81R)
- Power protection (32)
- Volts-per-hertz overexcitation (24)
- Resistance temperature detectors (RTD)
- Transformer status monitoring (TRF)
- Transformer thermal overload (49T)
- Transformer/motor/generator differential (87T/87M/87G)
- Programmable stage (99)
- Arc protection (50Arc/50Narc) (optional)
- Voltage memory

CONTROL:

- Objects to control and monitor (OBJ): 10
- Indicator objects to monitor (IND): 10
- Setting groups (SGS): 8
- Switch-on-to-fault (SOTF)

- Vector jump (78)
- Automatic voltage regulator (90) (AQ-T257B only)
- Synchrocheck (25)

MONITORING:

- Current transformer supervision (CTS) (2 instances)
- Voltage transformer supervision (VTS; 60)
- Circuit breaker wear monitoring (CBW)
- Current total harmonic distortion (THD)
- Voltage total harmonic distortion (THD)
- Fault locator (21FL)
- Disturbance records: 100 (à 5 s 3.2 kHz sampling)
- Non-volatile event records: 15,000

MEASUREMENTS:

- Phase, sequence, and residual currents ($I_A, I_B, I_C, I_{D1}, I_{D2}$)
- Phase, sequence, and residual voltages ($V_A, V_B, V_C, V_{AB}, V_{BC}, V_{CA}, V_D$)
- Frequency (f)
- Power (P, Q, S, cos φ) and energy (E+, E-, Eq+, Eq-)
- Power and energy measurement accuracy 0.5
- Power and energy measurement accuracy 0.2 % (optional)

HARDWARE:

- **Standard features:**
 - Digital inputs: 3
 - Output relays: 5
 - Current inputs: 10
 - Voltage inputs: 4
 - Empty module slots: 9

Optional hardware modules:

- Digital input module: 8 inputs
- Digital output module: 5 outputs
- Milliampere I/O module: 4 outputs + 1 input
- Arc protection module: 4 sensors + 2 HSO + 1 BI
- External I/O modules (see the "Accessories" page)

COMMUNICATION:

- **Standard inputs:**
 - 1 port with RJ-45 Ethernet 100 MB (front)
 - 1 port with RJ-45 Ethernet 100 MB (rear, COM A)
 - 1 port with RS-485 (rear, COM B)
- **Optional modules:**
 - 2 x RJ-45 Ethernet (100 MB/s) + IRIG-B input
 - 2 x ST Ethernet (100 MB/s) + IRIG-B input
 - 2 x LC Ethernet (100 MB/s, PRP/HSR)
 - RS-232 serial fiber (PP/PG/GP/PP)
- **Protocols:**
 - IEC 61850 (1st Edition)
 - IEC 61850 (2nd Edition)
 - IEC 60870-5-101/104
 - IEC 60870-5-103
 - Modbus/RTU and Modbus/TCP
 - DNP3
 - SPA

AQ-T257 Transformer protection device



READ MORE

AQ-T257 is a transformer protection device with a differential protection function and an integrated automatic voltage regulator function. The relay also provides complete current-based and voltage-based protection functions as well as full measurements you can add up to total 9 option modules (I/O and other type of modules) into the device for extensive monitoring

and control applications. AQ-T257 communicates using various protocols, including the IEC 61850.

SOFTWARE OPTIONS:

- AQ-T257A - standard transformer functionality
- AQ-T257B - standard transformer functionality + AVR

HIGHLIGHTS:

- A large I/O capacity.
- Automatic/manual voltage regulation and/or parallel voltage regulation (AVR).
- Complete transformer protection functionality.
- 2nd and 5th harmonic blocking.
- Automatic verification of connection group and nominal value settings.
- Overloading and through fault statistics for preventative maintenance.
- Optional power and energy measurement accuracy of 0.2 %.
- Includes IEC 61850 2nd Edition.

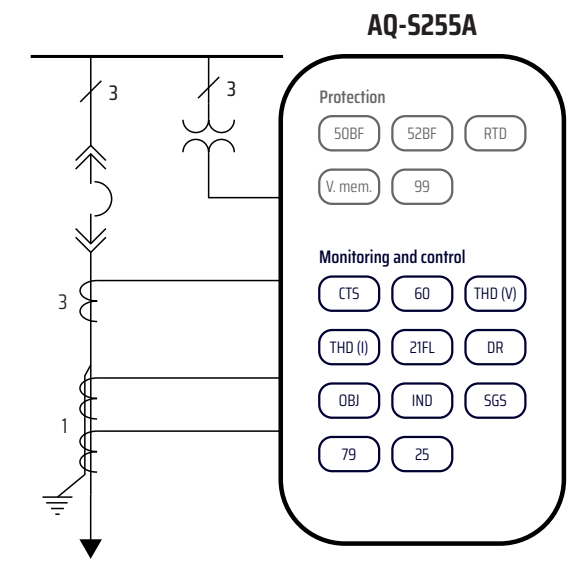
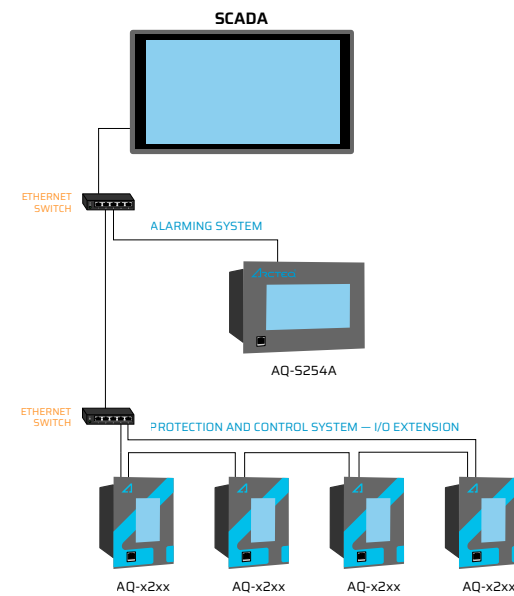

AQ-S254 Alarm and indication device



READ MORE

The AQ-S254 alarm and indication device can be applied to various substation tasks: extending the general I/O, sounding alarms, and control. You can add up to total 14 option modules (I/O and other type of modules) into the device, depending on the requirements of your application. The logic programming is powerful and easy to use. It also further expands the device's application range towards more demanding control, alarm and indication needs. The HMI is large and can be freely programmed, and provides a quick visualization of the object as well as the status of alarms and events. AQ-S254 communicates using various protocols, including the IEC 61850.

HIGHLIGHTS:

- Modern alarm sounding and a large I/O extension with IEC 61850 and GOOSE communication.
- Control and status indication for 20 objects.
- A full mimic diagram with busbar coloring.
- A full-color display for up to 128 alarms.
- Includes IEC 61850 2nd Edition.

ALARM, CONTROL, AND INDICATORS:

- Objects to control and monitor (OBJ): 10
- Indicator objects to monitor (IND): 20
- Alarms to program: 128
- Setting groups (SGS): 8
- Disturbance records: 100 (à 5 s 3.2 kHz sampling)
- Non-volatile event records: 15,000

HARDWARE:

- **Standard features:**
 - Digital inputs: 3
 - Output relays: 5
 - Empty module slots: 14
- **Optional hardware modules:**
 - Digital input module: 8 inputs

- Digital output module: 5 outputs
- Milliampere I/O module: 4 outputs + 1 input
- Arc protection module: 4 sensors + 2 HSO + 1 BI
- External I/O modules (see the "Accessories" page)

COMMUNICATION:

- **Standard inputs:**
 - 1 port with RJ-45 Ethernet 100 MB (front)
 - 1 port with RJ-45 Ethernet 100 MB (rear, COM A)
 - 1 port with RS-485 (rear, COM B)
- **Optional modules:**
 - 2 x RJ-45 Ethernet (100 MB/s) + IRIG-B input
 - 2 x ST Ethernet (100 MB/s) + IRIG-B input
 - 2 x LC Ethernet (100 MB/s, PRP/HSR)
 - RS-232 serial fiber (PP/PG/GP/PP)

PROTOCOLS:

- IEC 61850 (1st Edition)
- IEC 61850 (2nd Edition)
- IEC 60870-5-101/104
- IEC 60870-5-103
- Modbus/RTU and Modbus/TCP
- DNP3
- SPA

AQ-S255 Bay control device



READ MORE

The AQ-S255 bay control device can be applied to demanding control applications. AQ-S255 comes with full current, voltage, power, and energy measurement capabilities. You can add up to total 11 option modules (I/O and other type of modules), depending on the requirements of your application. The logic programming is powerful and easy to use, and it further expands

the device's application range towards more demanding control needs. The HMI is large and can be freely programmed, and it provides a quick visualization of the status of objects, alarms, and events. AQ-S255 communicates using various protocols, including the IEC 61850.

SOFTWARE OPTIONS:

- AQ-S255A - full current, voltage, power, and energy measurement capabilities
- AQ-S255B - full current, voltage, power, and energy measurement capabilities + AVR

PROTECTION:

- Circuit breaker failure protection (50BF/52BF)
- Resistance temperature detectors (RTD)
- Programmable stage (99)
- Voltage memory

CONTROL:

- Objects to control and monitor (OBJ): 10
- Indicator objects to monitor (IND): 20
- Setting groups (SGS): 8
- Auto-recloser (79)
- Synchrocheck (25)
- Automatic voltage regulator (90) (AQ-S255B only)

MONITORING:

- Current transformer supervision (CTS)
- Voltage transformer supervision (60)
- Circuit breaker wear monitoring (CBW)
- Current total harmonic distortion (THD)
- Voltage total harmonic distortion (THD)
- Fault locator (21FL)
- Disturbance records: 100 (à 5 s 3.2 kHz sampling)
- Non-volatile event records: 15,000

MEASUREMENTS:

- Phase, sequence, and residual currents ($I_A, I_B, I_C, I_{D1}, I_{D2}$)
- Phase, sequence, and residual voltages ($V_A, V_B, V_C, V_{AB}, V_{BC}, V_{CA}, V_{CB}$)
- Frequency (f)
- Power (P, Q, S, cos φ) and energy (E+, E-, Eq+, Eq-)
- Power and energy measurement accuracy 0.5
- Power and energy measurement accuracy 0.2% (optional)

HARDWARE:

- **Standard features:**
 - Digital inputs: 3
 - Output relays: 5
 - Current inputs: 5
 - Voltage inputs: 4
 - Empty module slots: 11
- **Optional hardware modules:**
 - Digital input module: 8 inputs
 - Digital output module: 5 outputs
 - Milliampere I/O module: 4 outputs + 1 input
 - Arc protection module: 4 sensors + 2 HSO + 1 BI
 - External I/O modules (see the "Accessories" page)

HIGHLIGHTS:

- A bay control device with extensive I/O capacity.
- Synchrocheck for up to 3 circuit breakers.
- Optional voltage regulator for controlling two or more transformers at the same time.
- Optional power and energy measurement accuracy of 0.2%.
- Includes IEC 61850 2nd Edition.

SELECTION TABLE

	Machine protection										Capacitor bank protection					Control monitoring and measuring	
	IEC	ANSI	AQ-M210	AQ-M215	AQ-M255A	AQ-M257A,-B	MotorCommander AQ-M257C	AQ-G215	AQ-G257A,-B	GeneratorCommander G257C,-D,-E,-F	AQ-C215	AQ-C255A,-B,-C,-D	AQ-S214	AQ-S254A	AQ-S215	AQ-S255A	AQ-S255B
Protection functions																	
Non-directional overcurrent protection	I>	50/51	•	•	•	•	•	•	•	•	•	•					
Non-directional ground fault protection	IO>	50N/51N	•	•	•	•	•	•	•	•	•						
Single-pole non-directional overcurrent protection	IPW>	50/51															
Directional overcurrent protection	Idir>	67		•	•	•	•	•	•	•	•						
Directional ground fault protection	IOdir>	67N/32N		•	•	•	•	•	•	•	•						
Intermittent ground fault protection	IOint>	67NT															
Negative sequence overcurrent/ Phase current reversal/ Current unbalance protection	I2>	46/46R/46L	•	•	•	•	•	•	•	•	•						
Harmonic overcurrent protection	Ih>	50H/51H/68H	•	•	•	•	•	•	•	•	•						
Circuit breaker failure protection	CBFP	50BF/52BF	•	•	•	•	•	•	•	•	•				•		•
High- and low-impedance restricted ground fault/ Cable-end differential protection	IOd>	87N	•	•	•	•	•	•	•	•	•						
Capacitor bank overload protection	Icol>	490L									•						
Capacitor bank neutral unbalance protection	Cnu>	50UB															
Capacitor bank current unbalance protection	Iuc>	46C									•						
Non-directional undercurrent protection	I<	37	•								•						
Voltage-restrained overcurrent protection	Iv>	51V															
Overvoltage protection	U>	59		•	•	•	•	•	•	•	•						
Undervoltage protection	U<	27		•	•	•	•	•	•	•	•						
Neutral overvoltage protection	V _n >	59N		•	•	•	•	•	•	•	•						
Sequence voltage protection	UI/U2-/<	47/27P/59PN		•	•	•	•	•	•	•	•						
Overfrequency and underfrequency protection	f>/<	810/81U		•	•	•	•	•	•	•	•						
Rate-of-change of frequency protection	df/dt>/<	81R		•	•	•	•	•	•	•	•						
Overpower protection	P>	320		•	•	•	•	•	•	•	•						
Underpower protection	P<	32U		•	•	•	•	•	•	•	•						
Reverse power protection	Pr	32R		•	•	•	•	•	•	•	•						
Power protection	P,Q,S>/<	32															
Volts-per-hertz overexcitation protection	V/Hz>	24															
Power factor protection	PF<	55		•	•	B	•	•	•	•	•						
Underexcitation protection	Q<	40				B	•	•	•	•	•						
Underimpedance protection	Z<	21U							•	•	•						
Line thermal overload protection	TF>	49F	•														
Resistance temperature detectors	RTD		•	•	•	•	•	•	•	•	•						
Motor status monitoring (MST)			•	•	•	•	•	•	•	•	•						
Machine/transformer differential protection	I _{dx} >	87T/87M/87G															
Motor start/ locked rotor monitoring	I _{st} >	48/14	•	•	•	•	•	•	•	•	•						
Machine thermal overload protection	TM>	49M	•	•	•	•	•	•	•	•	•						
Mechanical jam protection	Im>	51M	•	•	•	•	•	•	•	•	•						
100 % stator ground fault protection	V _{g3rd} >	64S															
Frequent start protection	N>	66	•	•	•	•	•	•	•	•	•						
Transformer status monitoring (TST)																	
Transformer thermal overload protection	TT>	49T															
Programmable stage	PGx>/<	99	•	•	•	•	•	•	•	•	•						
Voltage memory				•	•	•	•	•	•	•	•						
Arc protection	Iarc>/IOArc>	50Arc/50NArc	optional	optional	optional	optional	optional	optional	optional	optional	optional	optional	optional	optional	optional	optional	optional
Synchronous motor protection functions							A										
Asynchronous motor protection functions							B										
Control																	
Objects to control and monitor (OBJ)			5	5	10	10				5	10					10	10
Single-pole object monitoring (OBJ5)																	
Indicator objects to monitor (IND)			5	5	10	10				5	10					20	20
Programmable alarms																	
Cold load pick-up	CLPU		•														
Switch-on-to-fault	SOTF										•						
Automatic voltage regulator	AVR	90															
Auto-recloser	0 → 1	79												•	•	•	•
Zero sequence recloser	V _n > RECL	79N															
Vector jump	Δφ	78															
Synchrocheck	ΔV/Δa/Δf	25								•	•				•	•	•
Synchronizer	ΔV/Δa/Δf	25															
Excitation control (GC-30 unit included)									•								
PSS (Power system stabilizer)																	
Power Factor Controller (PFC)																	
Monitoring																	
Current transformer supervision (CTS)			•	•	•	•(2)				•	•(2)				•	•	•
Voltage transformer supervision (VTS)		60								•	•				•	•	•
Circuit breaker wear monitoring (CBW)			•	•	•	•				•	•				•	•	•
Current total harmonic distortion (THD)			•	•	•	•				•	•				•	•	•
Voltage total harmonic distortion (THD)				•	•	•				•	•				•	•	•
Fault locator		21FL													•	•	•
Disturbance recorder (max. 100 records)			•	•	•	•				•	•				•	•	•
Non-volatile event recorder (max. 15,000 records)			•	•	•	•				•	•				•	•	•
Running hour counter			•	•	•	•				•	•				•	•	•
Measurements																	
Phase, sequence, and residual currents (I _A , I _B , I _C , I ₀ , I ₂)			•	•	•	•				•	•				•	•	•
Phase, sequence, and residual voltages (V _A , V _B , V _C , V ₀ , V ₂)				•	•	•				•	•				•	•	•
Frequency (f)				•	•	•				•	•				•	•	•
Power (P, Q, S, cos φ) and energy (E+, E-, Eq+, Eq-)				•	•	•				•	•				•	•	•
Power and energy class 0.5%				•	•	•				•	•				•	•	•
Power and energy class 0.2%				optional	optional	optional	optional	optional	optional	optional	optional	optional	optional	optional	optional	optional	optional
Hardware																	
Digital inputs (standard)			3	3	3	3				3	3				3	3	3
Digital outputs (standard)			5	5	5	5				5	5				5	5	5
Current inputs			5	5	5	10				5	10				5	5	5
Voltage inputs				4	4	4				4	4				4	4	4
Empty module slots			4	3	11	9				3	9				3	11	11
Additional digital inputs (optional)			8...32	8...24	8...88	8...72				8...24	8...72				8...24	8...88	8...88
Additional digital outputs (optional)			5...10	5...10	5...30	5...30				5...10	5...30				5...10	5...30	5...30
Milliampere I/O module			optional	optional	optional	optional	optional	optional	optional	optional	optional	optional	optional	optional	optional	optional	optional
Arc protection module			optional	optional	optional	optional	optional	optional	optional	optional	optional	optional	optional	optional	optional	optional	optional
External I/O modules			optional	optional	optional	optional	optional	optional	optional	optional	optional	optional	optional	optional	optional	optional	optional
Communication interface																	
RJ-45 Ethernet 100 MB/s (front), RJ-45 Ethernet 100 MB/s and RS-485 (rear)			•	•	•	•				•	•				•	•	•
2x RJ-45 Ethernet 100 MB/s & IRIG-B input			optional	optional	optional	optional	optional	optional	optional	optional	optional	optional	optional	optional	optional	optional	optional
2x ST Ethernet 100 MB/s & IRIG-B input			optional	optional	optional	optional	optional	optional	optional	optional	optional	optional	optional	optional	optional	optional	optional
2x LC Ethernet 100 MB/s (PRP/HSR)			optional	optional	optional	optional	optional	optional	optional	optional	optional	optional	optional	optional	optional	optional	optional
RS-232 serial fiber (PP/PG/GP/GG)			optional	optional	optional	optional	optional	optional	optional	optional	optional	optional	optional	optional	optional	optional	optional
Communication protocols																	
IEC 61850 (1st Edition)			•	•	•	•				•	•				•	•	•
IEC 61850 (2nd Edition)																	
IEC 60870-5-103/101/104, Modbus/RTU, Modbus/TCP, DNP3, SPA			•	•	•	•											

CURRENT MEASUREMENT MODULE

Used for basic current measurements, the module has 5 channels: 3 three-phase current measurement inputs as well as 2 residual current inputs (coarse and fine). It can be ordered with standard or ring-lug connectors. The module is connected to the secondary side of a conventional CT. The module's nominal current for the phase current inputs is 5 A, and its measurement ranges are 25 mA...250 A (I_A-I_C), 5...150 A (I_{O1}), and 1 mA...75 A (I_{O2}).

VOLTAGE MEASUREMENT MODULE (4 CHANNELS)

Used for basic voltage measurements, the module has 4 channels. The inputs can be configured freely. The module is connected to the secondary side of a conventional VT, or directly to fuse-secured LV systems. The module's nominal voltage can be set between 100...400 V, and its measurement range is 0.5...480.0 V per channel.

VOLTAGE MEASUREMENT MODULE (3 CHANNELS)

Used for basic voltage measurements, the module has 3 channels. The inputs can be configured freely. The module also has 4 digital inputs. The module is connected to the secondary side of a conventional VT, or directly to fuse-secured LV systems. The module's nominal voltage can be set between 100...400 V, and its measurement range is 0.5...480.0 V per channel.

DIGITAL INPUT MODULE

Used for extending the I/O of a device, the module has 8 galvanically isolated digital inputs. Its properties follow those of the receiving device's CPU module (device series, auxiliary voltage range, and so on). The module's current consumption is 2 mA when activated, and its rated auxiliary voltage is 5...265 V AC/DC.

DIGITAL OUTPUT MODULE

Used for extending the I/O of a device, the module has 5 digital outputs. Its properties follow those of the receiving device's CPU module (device series, auxiliary voltage range, and so on). The module's rated auxiliary voltage is 265 V AC/DC.

ARC PROTECTION MODULE

Used for adding arc flash protection to a device, the module has 4 sensor channels, 2 high-speed outputs, and 1 binary input. Each sensor channel can have up to 3 point sensors connected serially, activated by arc light or by arch light and pressure. The high-speed outputs have a voltage withstand of max. 250 V DC, and their operating time is < 1 ms. The binary input can be used for external light information or as a part of an arc scheme.

RTD INPUT MODULE

Used for adding RTD measurements to a device, the module has 8 RTD input channels. Each input supports 2-wire, 3-wire, and 4-wire RTD sensors. The sensor type can be selected for two groups (4 channels/group) in the AQtivate 200 software. The module supports Pt100 and Pt1000 RTD sensors.

MILLIAMPERE I/O MODULE

Used for adding milliamper inputs and outputs to a device, the module has 4 mA outputs and 1 mA input. Both the input and the outputs are in two galvanically isolated groups; each group has one pin for the positive connector and one pin for the negative connector. The scaling range for the input is 0...4 000 mA, and for the outputs it is 0...24 mA.

2 x RJ-45 + IRIG-B COMMUNICATION MODULE

Used for multidrop configurations, the module has 2 RJ-45 connectors and a two-pin connector. The RJ-45 ports support Ethernet communication: one is 10BASE-T, the other 100BASE-TX. The two-pin connector is used as an IRIG-B timecode input.

2 x ST + IRIG-B COMMUNICATION MODULE

Used for a redundant ring configuration and multidrop configurations, the module has 2 ST connectors and a two-pin connector. The ST connectors are 100BASE-FX and are compatible with 62.5/125 μm or 50/125 μm multimode fibers of up to 2 km. Each ring can only contain AQ 200 series devices, and any third-party devices must be connected to a separate ring. The two-pin connector is used as an IRIG-B timecode input.

2 x LC COMMUNICATION MODULE (HSR, PRP)

Used for HSR and PRP redundancy protocols, the module has 2 LC connectors. The connectors have the data speed 100 Mbps and are compatible with 62.5/125 μm or 50/125 μm multimode glass fibers. Their wavelength is 1 300 nm.

2 x RJ-45 COMMUNICATION MODULE (HSR, PRP)

Used for HSR and PRP redundancy protocols, the module has 2 RJ-45 connectors. The ports support Ethernet communication: one is 10BASE-T, the other 100BASE-TX.

RS-232 SERIAL COMMUNICATION MODULE

Used for serial communication, the module has 1 RS-232 interface and 1 serial fiber interface. The serial fiber interface is compatible with ST connectors, and the fiber can be GG/PG/GP/PP. The fiber interface is compatible with 50/125 μm , 62.5/125 μm , 100/140 μm , and 200 μm plastic-clad silica (PCS) fibers.

Raising frame

When using a raising frame for installing an AQ 210 series protection device to a cabinet door, it leaves additional room for other installation equipment in the space behind the door. We offer two raising frame options: the first is 40 mm deep (AX010), and the other 87 mm deep (AX009). The selection depends on how much you need the device to jut out from the background.



COMBIFLEX frame

The COMBIFLEX frame (AX011) allows you to install an AQ 210 series device directly into a modular COMBIFLEX system.

Wall-mounting bracket

A wall-mounting bracket (AX012) is used for mounting an AQ 210 series protection device on a wall. The arm is fastened to the wall and then the device itself is mounted on the bracket and locked into place.



Raising frame

When using a raising frame for installing an AQ 250 series protection device to a cabinet door, it leaves additional room for other installation equipment in the space behind the door. We offer two raising frame options: the first is 40 mm deep (AX014), and the other 120 mm deep (AX013). The selection depends on how much you need the device to jut out from the background.



Wall-mounting bracket

A wall-mounting bracket (AX015) is used for mounting an AQ 250 series protection device on a wall. The arm is fastened to the wall and then the device itself is mounted on the bracket and locked into place.

Hardware

Current measurement module	
General information	
Spare part code	SP-2xx-CM
Compatibility	AQ 210 and AQ 250 series devices
Connections	
Measurement channels/ CT inputs	Three phase currents: I_A, I_B, I_C One coarse residual current (I01) One fine residual current (I02)
Phase current inputs	
Sample rate	64 samples per cycle (with frequency range 6...75 Hz)
Rated current (IN)	5 A (configurable 0.2...20 A) (AQ 210) 5 A (configurable 0.2...10 A) (AQ 250)
Thermal withstand	20 A (continuous) 100 A (10 s) 500 A (1 s) 1250 A (0.01 s)
Frequency measurement range	6...75 Hz fundamental, up to the 31st harmonic current
Current measurement range	25 mA...250 A (RMS)
Current measurement inaccuracy	0.005...4.000 × IN < ±0.5 % or ±15 mA 4...20 × IN < ±0.5 % 20...50 × IN < ±1.0 %
Angle measurement inaccuracy	< ±0.2 deg (I > 0.1 A) < ±1.0 deg (I ≤ 0.1 A)
Burden (50/60 Hz)	< 0.1 VA
Transient overreach	< 8 %
Coarse residual current input	
Rated current (IN)	1 A (configurable 0.1...10 A)
Thermal withstand	20 A (continuous) 100 A (10 s) 500 A (1 s) 1250 A (0.01 s)
Frequency measurement range	6...75 Hz fundamental, up to the 31st harmonic current
Current measurement range	5 mA...150 A (RMS)
Current measurement inaccuracy	0.002...10.000 × IN < ±0.5 % or ±3 mA 10...150 × IN < ±0.5 %
Angle measurement inaccuracy	< ±0.2 deg (I > 0.05 A) < ±1.0 deg (I ≤ 0.05 A)
Burden (50/60 Hz)	< ±1.0 deg (I ≤ 0.05 A)
Transient overreach	< 5 %
Fine residual current input	
Rated current (IN)	0.2 A (configurable 0.001...10 A)
Thermal withstand	25 A (continuous) 100 A (10 s) 500 A (1 s) 1250 A (0.01 s)
Frequency measurement range	6...75 Hz fundamental, up to the 31st harmonic current
Current measurement range	1 mA...75 A (RMS)
Current measurement inaccuracy	0.002...25.000 × IN < ±0.5 % or ±0.6 mA 25...375 × IN < ±1.0 %
Angle measurement inaccuracy	< ±0.2 deg (I > 0.01 A) < ±1.0 deg (I ≤ 0.01 A)
Burden (50/60 Hz)	< 0.1 VA
Transient overreach	< 5 %
Terminal block connection	
Terminal block	Phoenix Contact FRONT 4-H-6,35
Solid or stranded wire Maximum wire diameter	4 mm ²

Voltage measurement module (4 channels)	
General information	
Spare part code	SP-2xx-VT
Compatibility	AQ 210 and AQ 250 series devices
Connections	
Measurement channels/VT inputs	Four independent VT inputs: U1, U2, U3, and U4
Measurement	
Sample rate	64 samples per cycle (with frequency range 6...75 Hz)
Voltage measuring range	0.50...480.00 V (RMS)
Voltage measurement inaccuracy	1...2 V ±1.5 % 2...10 V ±0.5 % 10...480 V ±0.35 %
Angle measurement inaccuracy	< ±0.2 deg (15...300 V) < ±1.5 deg (1...15 V)
Voltage measurement bandwidth (freq.)	7...75 Hz fundamental, up to the 31st harmonic voltage
Terminal block connection	
Terminal block	Phoenix Contact PC 5/8-STCL1-7.62
Solid or stranded wire Maximum wire diameter	6 mm ²
Input impedance	Approx. 24.5 MΩ
Burden (50/60 Hz)	< 0.02 VA
Thermal withstand	630 VRMS (continuous)

Power and energy measurement accuracy	
Power measurements (P, Q, S)	
Inaccuracy	0.3 % < 1.2 × IN or 3 VA secondary 1.0 % > 1.2 × IN or 3 VA secondary
Energy measurement	
Energy and power metering inaccuracy	0.5 % down to 1 A RMS (50/60 Hz) (standard) 0.2 % down to 1 A RMS (50/60 Hz) (optional)

Frequency measurement accuracy	
Frequency measurement range	6...75 Hz fundamental, up to the 31st harmonic current or voltage
Inaccuracy	<1 mHz (AQ 210) 10 mHz (AQ 250)

CPU modules	
General information	
Spare part code	SP-210-CPU (AQ 210) SP-250-CPU (AQ 250)
Compatibility	AQ 210 and AQ 250 series devices
Connections	
Auxiliary voltage	80...265 V AC/DC or 18...72 V DC
Communication ports	1 × RJ-45 (front) 1 × RJ-45 (rear) 1 × RS-485 (rear)
Digital inputs	2 or 3 inputs (AQ 210) 3 inputs (AQ 250)
Digital outputs	5 + 1

CPU: Auxiliary voltage (AQ 210)	
Rated values	
Rated auxiliary voltage	80...265 V AC/DC (model H) 18...72 V DC (model L)
Power consumption	<7 W (without added option modules) <15 W (maximum number of added option modules)
Maximum permitted interrupt time	<60 ms with 110 V DC (model H) <90 ms with 24 V DC (model L)
DC ripple	<15 %
Terminal block connection	
Terminal bloc	Phoenix Contact MSTB 2,5/5-ST-5,08
Communication ports	2.5 mm2
Other	
Minimum recommended pulse rating	MCB C2

CPU: Auxiliary voltage (AQ 250)	
Rated values	
Rated auxiliary voltage	80...265 V AC/DC (model H) 18...72 V DC (model L)
Power consumption	<20 W (without added option modules) <40 W (maximum number of added option modules)
Maximum permitted interrupt time	<40 ms with 110 V DC (model H) <40 ms with 24 V DC (model L)
DC ripple	<15 %
Terminal block connection	
Terminal block	Phoenix Contact MSTB 2,5/5-ST-5,08
Communication ports	2.5 mm2
Other	
Minimum recommended pulse rating	MCB C2

CPU: Communication ports	
Front	
Number of ports	1
Port media	Copper Ethernet RJ-45
Port protocols	PC protocols FTP Telnet
Data transfer rate	100 MB/s
System integration	Cannot be used for system protocols, only for local programming

Rear (COM A)	
Number of ports	1
Port media	Copper Ethernet RJ-45
Port protocols	IEC 61850 IEC 104 Modbus/TCP DNP3 FTP Telnet
Data transfer rate	100 MB/s
System integration	Can be used for system protocols and for local programming

Rear (COM B)	
Number of ports	1
Port media	Copper RS-485
Port protocols	Modbus/RTU IEC 103 IEC 101 DNP3 SPA
Data transfer rate	65,580 kB/s
System integration	Can be used for system protocols

CPU: Digital inputs	
Rated values	
Rated auxiliary voltage	265 V AC/DC
Nominal voltage options	24 V AC/DC 110 V AC/DC 220 V AC/DC
Pick-up threshold options	19 V 90 V 170 V
Release threshold options	14 V 65 V 132 V
Scanning rate	5 ms
Settings	
Pick-up delay	0...1,800 s
Polarity	Normally ON Normally OFF
Current drain	2 mA
Terminal block connection	
Terminal block	Phoenix Contact MSTB 2,5/5-ST-5,08
Solid or stranded wire Maximum wire diameter	2.5 mm2

CPU: Digital outputs	
Rated values	
Rated auxiliary voltage	265 V AC/DC
Continuous carry	5 A (Normally Open) 2.5 A (Change-over)
Make and carry: 0.5 s 3 s	30 A 15 A
Breaking capacity, DC (L/R = 40 ms) at 48 V DC at 110 V DC at 220 V DC	1 A 0.4 A (Normally Open) 0.3 A (Change-over) 0.2 A (Normally Open) 0.15 A (Change-over)
Control rate	5 ms
Settings	
Polarity	Normally ON Normally OFF
Terminal block connection	
Terminal block	Phoenix Contact MSTB 2,5/5-ST-5,08
Solid or stranded wire Maximum wire diameter	2.5 mm2

Digital input module	
General information	
Spare part code	SP-210-DI8 (AQ 210) SP-250-DI8 (AQ 250)
Compatibility	AQ 210 and AQ 250 series devices
Rated values	
Rated auxiliary voltage	5...265 V AC/DC
Current drain	2 mA
Scanning rate	5 ms
Activation/release delay	5...11 ms
Settings	
Pick-up threshold	16...200 V
Release threshold	10...200 V
Pick-up delay	0...1,800 s
Drop-off delay	0...1,800 s
Polarity	Normally ON Normally OFF
Terminal block connection	
Standard screw connection terminal blocks	Phoenix Contact MSTB 2,5/10-ST-5,08
Spring cage terminal blocks (optional)	Phoenix Contact FK 2,5/10-STF-5,08
Solid or stranded wire Maximum wire diameter	2.5 mm2

Digital output module	
General information	
Spare part code	SP-210-DO5 (AQ 210) SP-250-DO5 (AQ 250)
Compatibility	AQ 210 and AQ 250 series devices
Rated values	
Rated auxiliary voltage	265 V AC/DC
Continuous carry	5 A
Make and carry: 0.5 s 3 s	30 A 15 A
Breaking capacity, DC (L/R = 40 ms) at 48 V DC at 110 V DC at 220 V DC	1 A 0.4 A 0.2 A
Control rate	5 ms
Settings	
Polarity	Normally ON Normally OFF
Terminal block connection	
Standard screw connection terminal blocks	Phoenix Contact MSTB 2,5/10-ST-5,08
Spring cage terminal blocks (optional)	Phoenix Contact FK 2,5/10-STF-5,08
Solid or stranded wire Maximum wire diameter	2.5 mm2

Arc protection module	
General information	
Spare part code	SP-2xx-ARC
Compatibility	AQ 210 and AQ 250 series devices
Connections	
Input arc point sensor channels	S1, S2, S3, and S4 (light only, or both pressure and light)
Sensors per channel	3
Performance	
Pick-up light intensity	8,000 lx 25,000 lx 50,000 lx
Point sensor detection radius	180 degrees
Start and instant operating time (light only)	Typically <5 ms (dedicated semiconductor outputs, HSO) Typically <10 ms (regular outputs relays)

High-speed outputs (HS01, HS02)	
Rated auxiliary voltage	250 V DC
Continuous carry	2 A
Make and carry: 0.5 s 3 s	15 A 6 A
Breaking capacity, DC (L/R = 40 ms)	1 A / 110 W
Control rate	5 ms
Operation delay	<1 ms
Polarity	Normally OFF
Contact material	Semiconductor
Standard screw connection terminal blocks	Phoenix Contact MSTB 2,5/5-ST-5,08
Solid or stranded wire Maximum wire diameter	2.5 mm2
Binary input channel	
Voltage withstand	265 V DC
Nominal voltage	24 V DC
Pick-up threshold	≥16 V DC
Release threshold	≤15 V DC
Scanning rate	5 ms
Polarity	Normally OFF
Current drain	3 mA
Standard screw connection terminal blocks	Phoenix Contact MSTB 2,5/5-ST-5,08
Solid or stranded wire Maximum wire diameter	2.5 mm2

RTD module	
General information	
Spare part code	SP-2xx-RTD
Compatibility	AQ 210 and AQ 250 series devices
Channels 1...8	
2/3/4-wire RTD	
Pt100 or Pt1000	

Milliampere I/O module	
General information	
Spare part code	SP-2xx-mA
Compatibility	AQ 210 and AQ 250 series devices
Signals	
Output magnitudes	4 × mA output signal (DC)
Input magnitudes	1 × mA input signal (DC)
mA input	
Hardware range	0...33 mA
Measurement range	0...24 mA
Inaccuracy	±0.1 mA
Update cycle	5...10,000 ms
Response time at 5-ms cycle	Appr. 15 ms (13...18 ms)
Update cycle time inaccuracy	Max. +20 ms above the set cycle
Input scaling range	0...4,000 mA
Output scaling range	-106...106 mA
mA output	
Inaccuracy at 0...24 mA	±0.01 mA
Response time at 5-ms cycle (fixed)	<5 ms
mA output scaling range	0...24 mA
Source signal scaling range	-106...106 mA
Terminal block connection	
Terminal block	Phoenix Contact MSTB 2,5/10-ST-5,08
Solid or stranded wire Maximum wire diameter	2.5 mm2

2 × RJ-45 + IRIG-B communication module	
General information	
Spare part code	SP-2xx-2RJ45
Compatibility	AQ 210 and AQ 250 series devices
Ports	2 × RJ-45 connectors 1 × IRIG-B connector
Protocols	
Protocols	Modbus/TCP Station bus communications
RJ-45 connectors	
Connector type	Copper Ethernet RJ-45 10BASE-T and 100BASE-TX
Port protocols	IEC 61850 Modbus/TCP IEC 104 FTP DNP/TCP
IRIG-B connector	
Connector type	Phoenix Contact MC 1,5/2-ST-3,5 BD: 1-2

2 × ST + IRIG-B communication module	
General information	
Spare part code	SP-2xx-2ST
Compatibility	AQ 210 and AQ 250 series devices
Ports	2 × ST connectors 1 × IRIG-B connector
Protocols	
Protocols	IEC 61850 Modbus/TCP IEC 104 FTP DNP/TCP
ST connectors	
Connector type	Duplex ST connectors 62.5/125 μm or 50/125 μm multimode fiber 100BASE-FX
Transmitter wavelength	1,260...1,360 nm (nominal: 1,310 nm)
Receiver wavelength	1,100...1,600 nm
Maximum distance	2 km
IRIG-B connector	
Connector type	Phoenix Contact MC 1,5/2-ST-3,5 BD: 1-2

2 × LC communication module	
General information	
Spare part code	SP-2xx-2LC(HSR/PRP)
Compatibility	AQ 210 and AQ 250 series devices
Protocols	
Protocols	HSR PRP
Ports	
Number of fiber ports	2
Communication ports C & D	LC fiber connector 100 MB/s Wavelength 1,300 nm
Fiber cable	50/125 μm or 62.5/125 μm multimode (glass)

2 × RJ-45 communication module	
General information	
Spare part code	SP-2xx-2RJ45(HSR/PRP)
Compatibility	AQ 210 and AQ 250 series devices
Protocols	
Protocols	HSR PRP
Ports	
Number of ports	2
Communication ports C & D	Copper Ethernet RJ-45 10BASE-T and 100BASE-TX
Fiber cable	50/125 μm or 62.5/125 μm multimode (glass)

RS-232 communication module	
General information	
Spare part code	SP-2xx-232PP (plastic-plastic) SP-2xx-232PG (plastic-glass) SP-2xx-232GP (glass-plastic) SP-2xx-232GG (glass-glass)
Compatibility	AQ 210 and AQ 250 series devices

Ports	
RS-232	
Serial fiber (PP/PG/GP/GG)	
Serial port wavelength	
660 nm	
Cable type	
1 mm plastic fiber	

Display	
AQ 210	
Spare part code	SP-210-DISP
Compatibility	AQ 210 series devices
Number of dots / Resolution	320 × 160
Size	84.78 × 49.90 mm (3.34 × 1.96 in)
Display type	LCD
Color	Monochrome
AQ 250	
Spare part code	SP-250-DISP
Compatibility	AQ 250 series devices
Number of dots / Resolution	800 × 400
Size	154.08 × 85.92 mm (6.06 × 3.38 in)
Display type	TFT
Color	RGB color

Protection functions

Non-directional overcurrent protection (50/51)	
Measurement inputs	
Current inputs	Phase current inputs: I_A, I_B, I_C
Current input magnitudes	RMS phase currents TRMS phase currents Peak-to-peak phase currents
Pick-up	
Pick-up current setting	0.10...50.00 × IN
Inrush 2nd harmonic blocking	0.10...50.00 × IFUND
Inaccuracy: Current 2nd harmonic blocking	±0.5 % ISET or ±15 mA (0.10...4.00 × ISET) ±1.0 %-unit of the 2nd harmonic setting
Operating time	
Definite time function operating time setting	0...1,800 s
Inaccuracy: Definite time: IM/ISET ratio > 3 Definite time: IM/ISET ratio = 1.05...3	±1.0 % or ±20 ms ±1.0 % or ±30 ms
IDMT setting parameters: K (time dial setting for IDMT) A (IDMT constant) B (IDMT constant) C (IDMT constant)	0.01...25.00 0...250 0...5 0...250
Inaccuracy: IDMT operating time IDMT minimum operating time	±1.5 % or ±20 ms ±20 ms
Retardation time (overshoot)	<30 ms

Instant operating time (AQ 210)	
Start time and instant operating time (trip): IM/ISET ratio > 3 IM/ISET ratio = 1.05...3	<35 ms (typically 25 ms) <50 ms
Instant operating time (AQ 250)	
Start time and instant operating time (trip): IM/ISET ratio = 2 IM/ISET ratio = 5 IM/ISET ratio = 10	<25 ms (typical) <16 ms (typical) <12 ms (typical)
Reset	
Reset ratio	97 % of the pick-up setting value
Reset time setting	0.01...10.00 s
Reset time inaccuracy	±1.0 % or ±50 ms
Instant reset time and start-up reset	<50 ms

Non-directional ground fault protection (50N/51N)	
Measurement inputs	
Current inputs (selectable)	Residual current channel I_{01} (coarse) Residual current channel I_{02} (fine) Calculated residual current: I_A, I_B, I_C
Current input magnitudes	RMS residual current (I_{01}, I_{02} , or calculated IO) TRMS residual current (I_{01} or I_{02}) Peak-to-peak residual current (I_{01} or I_{02})
Pick-up	
Used magnitudes	Measured residual current I_{01} (1 A) Measured residual current I_{02} (0.2 A) Calculated residual current IOCalc (5 A)
Pick-up current setting	0.0001...40.0000 × IN
Inaccuracy: Starting I_{01} (1 A) Starting I_{02} (0.2 A) Starting IOCalc (5 A)	±0.5 % IOSET or ±3 mA (0.005...10.000 × ISET) ±1.5 % ISET or ±1 mA (0.005...25.000 × ISET) ±1.0 % ISET or ±15 mA (0.005...4.000 × ISET)
Operating time	
Definite time function operating time setting	0...1,800 s
Inaccuracy: Definite time: IM/ISET ratio > 3 Definite time: IM/ISET ratio = 1.05...3	±1.0 % or ±20 ms ±1.0 % or ±30 ms
IDMT setting parameters: K (time dial setting for IDMT) A (IDMT constant) B (IDMT constant) C (IDMT constant)	0.01...25.00 0...250 0...5 0...250
Inaccuracy: IDMT operating time IDMT minimum operating time	±1.5 % or ±20 ms ±20 ms
Retardation time (overshoot)	<30 ms

Instant operating time	
Start time and instant operating time (trip): IM/ISET ratio > 3 IM/ISET ratio = 1.05...3	<50 ms (typically 35 ms) <55 ms
Reset	
Reset ratio	97 % of the pick-up setting value
Reset time setting	0.01...10.00 s
Reset time inaccuracy	±1.0 % or ±50 ms
Instant reset time and start-up reset	<50 ms

Single-pole non-directional overcurrent protection (50/51)	
Measurement inputs	
Current inputs	Phase current inputs: I_A, I_B, I_C
Current input magnitudes	RMS phase currents TRMS phase currents Peak-to-peak phase currents
Pick-up	
Pick-up current setting	0.10...50.00 × IN
Inrush 2nd harmonic blocking	0.10...50.00 × IFUND
Inaccuracy: Current 2nd harmonic blocking	±0.5 % ISET or ±15 mA (0.10...4.00 × ISET) ±1.0 %-unit of the 2nd harmonic setting
Operating time	
Definite time function operating time setting	0...1,800 s
Inaccuracy: Definite time: IM/ISET ratio > 3 Definite time: IM/ISET ratio = 1.05...3	±1.0 % or ±20 ms ±1.0 % or ±30 ms
IDMT setting parameters: K (time dial setting for IDMT) A (IDMT constant) B (IDMT constant) C (IDMT constant)	0.01...25.00 0...250 0...5 0...250
Inaccuracy: IDMT operating time IDMT minimum operating time	±1.5 % or ±20 ms ±20 ms
Retardation time (overshoot)	<30 ms
Instant operating time	
Start time and instant operating time (trip): IM/ISET ratio = 2 IM/ISET ratio = 5 IM/ISET ratio = 10	<25 ms (typical) <16 ms (typical) <12 ms (typical)
Reset	
Reset ratio	97 % of the pick-up setting value
Reset time setting	0.01...10.00 s
Reset time inaccuracy	±1.0 % or ±50 ms
Instant reset time and start-up reset	<50 ms

Directional overcurrent protection (67)	
Input signals	
Current inputs	Phase current inputs: I_A, I_B, I_C
Current input magnitudes	RMS phase currents TRMS phase currents Peak-to-peak phase currents
Current input calculations	Positive sequence current angle
Voltage inputs	V_A, V_B, V_C $V_{AB}, V_{BC}, V_{CA} + V_0$
Voltage input calculations	Positive sequence voltage angle
Pick-up	
Characteristic direction	Directional Non-directional
Operating sector center	-180...180°
Operating sector size (+/-)	1...170
Pick-up current setting	0.10...40.00 × IN
Inaccuracy: Current U1/I1 angle (U > 15 V) U1/I1 angle (U = 1...15 V)	±0.5 % ISET or ±15 mA (0.10...4.00 × ISET) ±0.20° ±1.5°

Operating time	
Definite time function operating time setting	0...1,800 s
Inaccuracy: Definite time: IM/ISET ratio > 3 Definite time: IM/ISET ratio = 1.05...3	±1.0 % or ±20 ms ±1.0 % or ±35 ms
IDMT setting parameters: K (time dial setting for IDMT) A (IDMT constant) B (IDMT constant) C (IDMT constant)	0.01...25.00 0...250 0...5 0...250
Inaccuracy: IDMT operating time IDMT minimum operating time	±1.5 % or ±20 ms ±20 ms
Instant operating time	
Start time and instant operating time (trip): IM/ISET ratio > 3 IM/ISET ratio = 1.05...3	<40 ms (typically 30 ms) <50 ms
Reset	
Reset ratio: Current UI/I1 angle	97 % of the pick-up setting value 2.0°
Reset time setting	0.01...10.00 s
Reset time inaccuracy	±1.0 % or ±50 ms
Instant reset time and start-up reset	<50 ms

Directional ground fault protection (67N/32N)

Measurement inputs	
Current inputs (selectable)	Residual current channel I ₀₁ (coarse) Residual current channel I ₀₂ (fine) Calculated residual current: I _A , I _B , I _C
Current input magnitudes	RMS residual current (I ₀₁ , I ₀₂ or calculated ID) TRMS residual current (I ₀₁ or I ₀₂) Peak-to-peak residual current (I ₀₁ or I ₀₂)
Voltage inputs (selectable)	Residual voltage from the U3 voltage channel (AQ-F213x) Residual voltage from U3 or U4 voltage channel (others) Residual voltage calculated from V _A , V _B , V _C
Voltage input magnitudes	RMS residual voltage (V ₀) Calculated RMS residual voltage (V ₀)
Pick-up	
Characteristic direction	Unearthed (varmetric 90°) Peterson coil GND (wattmetric 180°) Earthed (adjustable sector)
When the "Earthed" mode is active: Tripping area center Tripping area size (+/-)	0...360° 45...135°
Pick-up current setting	0.05...40.00 × IN
Pick-up voltage setting	1...50 %V _{0N} (AQ-F213x) 1...75 %V _{0N} (others)
Inaccuracy: Starting I ₀₁ (1 A) Starting I ₀₂ (0.2 A) Starting I _{0Calc} (5 A) Voltage V ₀ and V _{0Calc} V ₀ /I ₀ angle (U > 15 V) V ₀ /I ₀ angle (U = 1...15 V)	±0.5 %I _{0SET} or ±3 mA (0.005...10.000 × ISET) ±1.5 %ISET or ±1 mA (0.005...25.000 × ISET) ±1.5 %ISET or ±15 mA (0.005...4.000 × ISET) ±1.0 %V _{0SET} or ±30 mV ±0.2° (I _{0Calc} ±1.0°) ±1.0°
Operating time	
Definite time function operating time setting	0...1,800 s
Inaccuracy: Definite time: IM/ISET ratio 1.05→	±1.0 % or ±30 ms (AQ-F213x) ±1.0 % or ±45 ms (others)

IDMT setting parameters: K (time dial setting for IDMT) A (IDMT constant) B (IDMT constant) C (IDMT constant)	0.01...25.00 0...250 0...5 0...250
Inaccuracy: IDMT operating time IDMT minimum operating time	±1.5 % or ±25 ms ±20 ms
Instant operating time	
Start time and instant operating time (trip): IM/ISET ratio > 3 IM/ISET ratio = 1.05...3	<55 ms (typically 45 ms) <65 ms
Reset	
Current and voltage reset	97 % of the pick-up setting value
V ₀ /I ₀ angle	2.0°
Reset time setting	0...150 s
Reset time inaccuracy	±1.0 % or ±45 ms
Instant reset time and start-up reset	<50 ms

Intermittent ground fault protection (67NT)

Measurement inputs	
Current inputs (selectable)	Residual current channel I ₀₁ (coarse) Residual current channel I ₀₂ (fine)
Current input magnitudes	Residual current samples
Voltage inputs (selectable)	Residual voltage from U3 or U4 voltage channel
Voltage input magnitudes	Zero sequence voltage samples
Pick-up	
Spikes to trip	1...50
Pick-up current setting	0.05...40.00 × IN
Pick-up voltage setting	1...100 %V _{0N}
Inaccuracy: Starting I ₀₁ (1 A) Starting I ₀₂ (0.2 A) Voltage V ₀	±0.5 %I _{0SET} or ±3 mA (0.005...10.000 × ISET) ±1.5 %ISET or ±1.0 mA (0.005...25.000 × ISET) ±1.0 %V _{0SET} or ±30 mV
Operating time	
Definite time function operating time setting	0...1,800 s
Inaccuracy: Definite time: IM/ISET ratio 1.05→	±1.0 % or ±30 ms
Instant operating time	
Start time and instant operating time (trip): IM/ISET ratio 1.05→	<15 ms
Reset	
Reset time setting (FWD and REV)	0...1,800 s
Reset time inaccuracy	±1.0 % or ±35 ms
Instant reset time and start-up reset	<50 ms

Negative sequence overcurrent protection, Phase current reversal protection, Current unbalance protection (46/46R/46L)

Measurement inputs	
Current inputs	Phase current inputs: I _A , I _B , I _C
Current input calculations	Positive sequence current (I1) Negative sequence current (I2)
Pick-up	
Used magnitudes	Negative sequence component (I2pu) Relative unbalance (I2/I1)
Pick-up setting	0.10...40.00 × IN (I2pu) 1...200 % (I2/I1)

Minimum phase current (at least one phase above)	0.01...2.00 × IN
Inaccuracy: Starting I2pu Starting I2/I1	±1.0 %-unit or ±100 mA (0.10...4.00 × IN) ±1.0 %-unit or ±100 mA (0.10...4.00 × IN)
Operating time	
Definite time function operating time setting	0...1,800 s
Inaccuracy: Definite time: IM/ISET ratio > 1.05	±1.5 % or ±60 ms
IDMT setting parameters: K (time dial setting for IDMT) A (IDMT constant) B (IDMT constant) C (IDMT constant)	0.01...25.00 0...250 0...5 0...250
Inaccuracy: IDMT operating time IDMT minimum operating time	±2.0 % or ±30 ms ±20 ms
Retardation time (overshoot)	<5 ms
Instant operating time	
Start time and instant operating time (trip): IM/ISET ratio > 1.05	<70 ms
Reset	
Reset ratio	97 % of the pick-up setting value
Reset time setting	0.01...10.00 s
Reset time inaccuracy	±1.5 % or ±60 ms
Instant reset time and start-up reset	<55 ms

Harmonic overcurrent protection (50H/51H/68H)

Measurement inputs	
Current inputs	Phase current inputs: I _A , I _B , I _C Residual current channel I ₀₁ (coarse) Residual current channel I ₀₂ (fine)
Pick-up	
Harmonic selection	2nd, 3rd, 4th, 5th, 6th, 7th, 9th, 11th, 13th, 15th, 17th, and 19th
Used magnitudes	Harmonic per unit (× IN) Harmonic relative (Ih/IL)
Pick-up setting	0.05...2.00 × IN (× IN) 5...200 % (Ih/IL)
Inaccuracy: Starting × IN Starting Ih/IL	<0.03 × IN (2nd, 3rd, 5th) <0.03 × IN tolerance to Ih (2nd, 3rd, 5th)
Operating time	
Definite time function operating time setting	0...1,800 s
Inaccuracy: Definite time: IM/ISET ratio > 1.05	±1.0 % or ±35 ms
IDMT setting parameters: K (time dial setting for IDMT) A (IDMT constant) B (IDMT constant) C (IDMT constant)	0.01...25.00 0...250 0...5 0...250
Inaccuracy: IDMT operating time IDMT minimum operating time	±1.5 % or ±20 ms ±20 ms
Instant operating time	
Start time and instant operating time (trip): IM/ISET ratio > 1.05	<50 ms
Reset	
Reset ratio	95 % of the pick-up setting value
Reset time setting	0.01...10.00 s
Reset time inaccuracy	±1.0 % or ±35 ms
Instant reset time and start-up reset	<50 ms

Circuit breaker failure protection (50BF/52BF)

Measurement inputs	
Current inputs	Phase current inputs: I _A , I _B , I _C Residual current channel I ₀₁ (coarse) Residual current channel I ₀₂ (fine)
Current input magnitudes	RMS phase currents (I _A , I _B , I _C) RMS residual current (I ₀₁ , I ₀₂ or calculated ID)
Pick-up	
Monitored signals	Digital input status Digital output status Logical signals
Pick-up setting: I _A ...I _C I ₀₁ , I ₀₂ , I _{0Calc}	0.10...40.00 × IN 0.005...40.000 × IN
Inaccuracy: Starting phase current (5 A) Starting I ₀₁ (1 A) Starting I ₀₂ (0.2 A) Starting I _{0Calc} (5 A)	±0.5 %ISET or ±15 mA (0.10...4.00 × ISET) ±0.5 %ISET or ±3 mA (0.005...10.000 × ISET) ±1.5 %ISET or ±1 mA (0.005...25.000 × ISET) ±1.0 %ISET or ±15 mA (0.005...4.00 × ISET)
Operating time	
Definite time function operating time setting	0...1,800 s
Inaccuracy: Current criteria: IM/ISET ratio 1.05→ DO or DI only	±1.0 % or ±55 ms ±15 ms
Reset	
Reset ratio	97 % of the pick-up setting value
Reset time	<50 ms

Low-impedance or high-impedance restricted ground fault protection, Cable-end differential protection (87N)

Measurement inputs	
Current inputs	Phase current inputs: I _A , I _B , I _C Residual current channel I ₀₁ (coarse) Residual current channel I ₀₂ (fine)
Current input calculations	Calculated bias and residual differential currents
Pick-up	
Operating modes	Restricted ground fault Cable-end differential
Characteristics	Biased differential with 3 settable sections and 2 slopes
Pick-up current sensitivity setting	0.01...50.00 % (IN)
Slope 1	0...150 %
Slope 2	0...250 %
Bias (turn points 1 & 2)	0.01...50.00 × IN
Inaccuracy	±3 % of the pick-up value > 0.5 × IN setting
Starting inaccuracy	±5 mA < 0.5 × IN setting
Operating time	
Instant operation time (1.05 × ISET)	<30 ms
Reset	
Reset ratio	No hysteresis
Reset time	<40 ms

Overvoltage protection (59)	
Measurement inputs	
Voltage inputs	Phase voltage inputs: V_A, V_B, V_C Phase-to-phase voltage inputs: V_{AB}, V_{BC} (AQ-F213x) Phase-to-phase voltage inputs: V_{AB}, V_{BC}, V_{CA} (others) Residual voltage input: V_0
Voltage input magnitudes	RMS line-to-line or line-to-neutral voltages
Pick-up	
Pick-up terms	1 voltage 2 voltages 3 voltages
Pick-up setting	50...150 %UN
Inaccuracy	±3.5 %USET (AQ-F213x) ±1.5 %USET (others)
Operating time	
Definite time function operating time setting	0...1,800 s
Inaccuracy: Definite time: UM/USET ratio 1.05→	±1.0 % or ±35 ms
IDMT setting parameters:	
K (time dial setting for IDMT)	0.01...25.00
A (IDMT constant)	0...250
B (IDMT constant)	0...5
C (IDMT constant)	0...250
Inaccuracy: IDMT operating time IDMT minimum operating time	±1.5 % or ±20 ms ±20 ms
Instant operating time	
Start time and instant operating time (trip): UM/USET ratio 1.05→	<50 ms
Reset	
Reset ratio	97 % of the pick-up setting value
Reset time setting	0.01...10.00 s
Reset time inaccuracy	±1.0 % or ±35 ms (AQ-F213x) ±1.0 % or ±45 ms (others)
Instant reset time and start-up reset	<50 ms
Undervoltage protection (27)	
Measurement inputs	
Voltage inputs	Phase voltage inputs: V_A, V_B, V_C Phase-to-phase voltage inputs: V_{AB}, V_{BC} (AQ-F213x) Phase-to-phase voltage inputs: V_{AB}, V_{BC}, V_{CA} (others) Residual voltage (V_0)
Voltage input magnitudes	RMS line-to-line or line-to-neutral voltages
Pick-up	
Pick-up terms	1 voltage 2 voltages 3 voltages
Pick-up setting	20...120 %UN (AQ-F213x) 0...120 %UN (others)
Inaccuracy	±3.5 %USET (AQ-F213x) ±1.5 %USET or ±30 mV (others)
Operating time	
Definite time function operating time setting	0...1,800 s
Inaccuracy: Definite time: UM/USET ratio 1.05→	±1.0 % or ±35 ms
IDMT setting parameters:	
K (time dial setting for IDMT)	0.01...25.00
A (IDMT constant)	0...250
B (IDMT constant)	0...5
C (IDMT constant)	0...250
Inaccuracy: IDMT operating time IDMT minimum operating time	±1.5 % or ±20 ms ±20 ms

Instant operating time	
Start time and instant operating time (trip): UM/USET ratio 1.05→	<65 ms
Retardation time (overshoot)	<30 ms
Reset	
Reset ratio	103 % of the pick-up setting value
Reset time setting	0.01...10.00 s
Reset time inaccuracy	±1.0 % or ±45 ms
Instant reset time and start-up reset	<50 ms

Neutral overvoltage protection (59N)	
Measurement inputs	
Voltage inputs	Residual voltage from the U3 voltage channel (AQ-F213x) Residual voltage from U3 or U4 voltage channel (others) Residual voltage calculated from V_A, V_B, V_C
Voltage input magnitudes	RMS residual voltage (V_0) Calculated RMS residual voltage (V_0Calc)
Pick-up	
Pick-up setting	1...50 % V_0N
V_0 inaccuracy	±3.5 %USET or ±30 mV (AQ-F213x) ±1.5 %USET or ±30 mV (others)
V_0Calc inaccuracy	±400 mV (AQ-F213x) ±150 mV (others)
Operating time	
Definite time function operating time setting	0...1,800 s
Inaccuracy: Definite time: V_0M/V_0SET ratio 1.05→	±1.0 % or ±35 ms (AQ-F213x) ±1.0 % or ±45 ms (others)
IDMT setting parameters:	
K (time dial setting for IDMT)	0.01...25.00
A (IDMT constant)	0...250
B (IDMT constant)	0...5
C (IDMT constant)	0...250
Inaccuracy: IDMT operating time IDMT minimum operating time	±1.5 % or ±20 ms ±20 ms

Instant operating time	
Start time and instant operating time (trip): V_0M/V_0SET ratio 1.05→	<50 ms
Reset	
Reset ratio	97 % of the pick-up setting value
Reset time setting	0...150 s
Reset time inaccuracy	±1.0 % or ±35 ms (AQ-F213x) ±1.0 % or ±50 ms (others)
Instant reset time and start-up reset	<50 ms

Sequence voltage protection (47/27P/59NP)	
Measurement inputs	
Voltage inputs	Phase voltage inputs: V_A, V_B, V_C Phase-to-phase voltage inputs: V_{AB}, V_{BC}, V_{CA} Residual voltage input: V_0
Voltage input calculations	Positive sequence voltage (I1) Negative sequence voltage (I2)
Pick-up	
Pick-up setting	5...150 %UN
Inaccuracy	±1.5 %USET or ±30 mV
Low-voltage block	
Pick-up setting	1...80 %UN
Inaccuracy	±1.5 %USET or ±30 mV

Operating time	
Definite time function operating time setting	0...1,800 s
Inaccuracy: Definite time: UM/USET ratio 1.05→	±1.0 % or ±35 ms
IDMT setting parameters:	
K (time dial setting for IDMT)	0.01...25.00
A (IDMT constant)	0...250
B (IDMT constant)	0...5
C (IDMT constant)	0...250
Inaccuracy: IDMT operating time IDMT minimum operating time	±1.5 % or ±20 ms ±20 ms

Instant operating time	
Start time and instant operating time (trip): UM/USET ratio 1.05→	<65 ms
Reset	
Reset ratio	97 % or 103 % of the pick-up setting value
Reset time setting	0.01...10.00 s
Reset time inaccuracy	±1.0 % or ±35 ms
Instant reset time and start-up reset	<50 ms

Overfrequency and underfrequency protection (810/81U)	
Input signals	
Sampling modes	Fixed Tracked
Frequency references:	
Reference 1	CT11A, CT21A, VT1U1, VT2U1
Reference 2	CT11B, CT21B, VT1U2, VT2U2
Reference 3	CT11C, CT21C, VT1U3, VT2U3
Pick-up	
f> pick-up setting	10...70 Hz
f< pick-up setting	7...65 Hz
Inaccuracy: "Fixed" sapling mode "Tracked" sapling mode	±20 mHz (50/60 Hz fixed frequency) ±20 mHz (U > 30 V secondary) ±20 mHz (I > 30 % of rated secondary)
Operating time	
Definite time function operating time setting	0...1,800 s
Inaccuracy: Definite time: IM/ISET ratio ±50 mHz	±1.5 % or ±50 ms
Instant operating time	
Start time and instant operating time (trip): IM/ISET ratio ±50 mHz (fixed) IM/ISET ratio ±50 mHz (tracked)	<70 ms <3 cycles or <60 ms
Reset	
Reset ratio	0.02 Hz
Instant reset time and start-up reset: IM/ISET ratio ±50 mHz (fixed) IM/ISET ratio ±50 mHz (tracked)	<110 ms <3 cycles or <70 ms

Rate-of-change of frequency protection (81R)	
Input signals	
Sampling modes	Fixed Tracked
Frequency references:	
Reference 1	CT11A, CT21A, VT1U1, VT2U1
Reference 2	CT11B, CT21B, VT1U2, VT2U2
Reference 3	CT11C, CT21C, VT1U3, VT2U3

Pick-up	
df/dt>/< pick-up setting	0.15...1.00 Hz/s
Limits: f> limit f< limit	10...70 Hz 7...65 Hz
df/dt inaccuracy	±5 %ISET or ±20 mHz/s (AQ-210) ±5 %ISET or ±30 mHz/s (AQ-250)
Frequency inaccuracy	±15 mHz (U > 30 V secondary) ±20 mHz (I > 30 % of rated secondary)
Operating time	
Definite time function operating time setting	0...1,800 s
Inaccuracy: Definite time: IM/ISET ratio ±50 mHz	±1.5 % or ±110 ms
Instant operating time	
Start time and instant operating time (trip): fM/fSET ratio ±200 mHz (overreach)	<150 ms (AQ 210) <200 ms (AQ 250) <90 ms
fM/fSET ratio ±200 mHz (overreach)	
Reset	
Reset ratio of the frequency limit	±0.02 Hz
df/dt	±10 % of pick-up or 50 mHz/s (AQ 250)
Instant reset time and start-up reset: fM/fSET ratio ±50 mHz	<2 cycles or <60 ms (AQ 210) <325 ms (AQ 250)

Overpower protection (320) Underpower protection (32U) Reverse power protection (32R)	
Measurement inputs	
Current inputs	Phase current inputs: I_A, I_B, I_C
Voltage inputs	Phase voltage inputs: V_A, V_B, V_C Phase-to-phase voltage inputs: V_{AB}, V_{BC} (AQ-F213x) Phase-to-phase voltage inputs: V_{AB}, V_{BC}, V_{CA} (others) Residual voltage input: V_0
Calculated measurements	Three-phase active power
Pick-up	
P>	0.10 kW...150.00 MW
P<	-15...-1.00 kW
Pr	0.10 kW...150.00 MW
PSET<	0.10 kW...100.00 MW
Active power inaccuracy	Typically <3.0 %PSET (AQ-F213x) Typically <1.0 %PSET (others)
Operating time	
Definite time function operating time setting	0...1,800 s
Inaccuracy: Definite time: PM/PSET ratio 1.05→	±1.0 % or ±35 ms
Instant operating time	
Start time and instant operating time (trip): PM/PSET ratio 1.05→	<50 ms
Reset	
Reset ratio	97 % or 103 % of PSET
Reset time setting	0...150 s
Reset time inaccuracy	±1.0 % or ±35 ms
Instant reset time and start-up reset	<50 ms

Power protection (32)	
Measurement inputs	
Current inputs	Phase current inputs: I_A, I_B, I_C
Voltage inputs	Phase voltage inputs: V_A, V_B, V_C Phase-to-phase voltage inputs: V_{AB}, V_{BC}, V_{CA} Residual voltage input: V_D
Calculated measurements	Three-phase active power (P), three-phase reactive power (Q), three-phase apparent power (S) (values based on the selected or set nominal amplitude)
Pick-up	
Comparator selection	> or <
Range	-500...500 %/MVAN
Inaccuracy	Typically <1.0 %PSET
Operating time	
Definite time function operating time setting	0...1,800 s
Inaccuracy: Definite time: PM/PSET ratio 1.05→	±1.0 % or ±35 ms
Instant operating time	
Start time and instant operating time (trip): PQSM/PQSSET ratio 1.05→	<40 ms
Reset	
Reset ratio	97 % or 103 % of PSET
Instant reset time and start-up reset	<40 ms

Capacitor bank overload protection (490L)	
Input signals	
Current inputs	Phase current inputs: I_A, I_B, I_C
Current input magnitudes	RMS phase currents TRMS phase currents Peak-to-peak phase currents
Pick-up	
Pick-up setting	0.10...50.00 × IN
Inrush 2nd harmonic blocking	0.10...50.00 %IFUND
Inaccuracy: Current 2nd harmonic blocking	±0.5 %ISET or ±15 mA (0.10...4.00 × ISET) ±1.0 %-unit of the 2nd harmonic setting
Operating time	
Definite time function operating time setting	0...1,800 s
Inaccuracy: Definite time: IM/ISET ratio > 3 Definite time: IM/ISET ratio = 1.05...3	±1.0 % or ±20 ms ±1.0 % or ±30 ms
IDMT setting parameters: K (time dial setting for IDMT) A (IDMT constant) B (IDMT constant) C (IDMT constant)	0.01...25.00 0...250 0...5 0...250
Inaccuracy: IDMT operating time IDMT minimum operating time	±1.5 % or ±20 ms ±20 ms
Retardation time (overshoot)	<25 ms
Instant operating time	
Start time and instant operating time (trip): IM/ISET ratio > 3 IM/ISET ratio = 1.05...3	<35 ms (typically 25 ms) <50 ms
Reset	
Reset ratio	97 % of the pick-up setting value
Reset time setting	0.01...10.00 s
Reset time inaccuracy	±1.0 % or ±50 ms
Instant reset time and start-up reset	<50 ms

Reset ratio	97 % of the pick-up setting value
Reset time setting	0.01...10.00 s
Reset time inaccuracy	±1.0 % or ±50 ms
Instant reset time and start-up reset	<50 ms

Capacitor bank neutral unbalance protection (50UB)	
Measurement inputs	
Current inputs	Phase current inputs: I_A, I_B, I_C
Current input magnitudes	RMS phase currents TRMS phase currents Peak-to-peak phase currents
Pick-up	
Pick-up setting	0.10...50.00 × IN
Inrush 2nd harmonic blocking	0.10...50.00 %IFUND
Inaccuracy: Current 2nd harmonic blocking	±0.5 %ISET or ±15 mA (0.10...4.00 × ISET) ±1.0 %-unit of the 2nd harmonic setting
Operating time	
Definite time function operating time setting	0...1,800 s
Inaccuracy: Definite time: IM/ISET ratio > 3 Definite time: IM/ISET ratio = 1.05...3	±1.0 % or ±20 ms ±1.0 % or ±30 ms
IDMT setting parameters: K (time dial setting for IDMT) A (IDMT constant) B (IDMT constant) C (IDMT constant)	0.01...25.00 0...250 0...5 0...250
Inaccuracy: IDMT operating time IDMT minimum operating time	±1.5 % or ±20 ms ±20 ms
Retardation time (overshoot)	<25 ms
Instant operating time	
Start time and instant operating time (trip): IM/ISET ratio > 3 IM/ISET ratio = 1.05...3	<35 ms (typically 25 ms) <50 ms
Reset	
Reset ratio	97 % of the pick-up setting value
Reset time setting	0.01...10.00 s
Reset time inaccuracy	±1.0 % or ±50 ms
Instant reset time and start-up reset	<50 ms

Capacitor bank current unbalance protection (46C)	
Measurement inputs	
Current inputs	Phase current inputs: I_A, I_B, I_C
Current input magnitudes	RMS phase currents TRMS phase currents Peak-to-peak phase currents
Pick-up	
Pick-up setting	0.10...50.00 × IN
Inrush 2nd harmonic blocking	0.10...50.00 %IFUND
Inaccuracy: Current 2nd harmonic blocking	±0.5 %ISET or ±15 mA (0.10...4.00 × ISET) ±1.0 %-unit of the 2nd harmonic setting

Operating time	
Definite time function operating time setting	0...1,800 s
Inaccuracy: Definite time: IM/ISET ratio > 3 Definite time: IM/ISET ratio = 1.05...3	±1.0 % or ±20 ms ±1.0 % or ±30 ms
IDMT setting parameters: K (time dial setting for IDMT) A (IDMT constant) B (IDMT constant) C (IDMT constant)	0.01...25.00 0...250 0...5 0...250
Inaccuracy: IDMT operating time IDMT minimum operating time	±1.5 % or ±20 ms ±20 ms
Retardation time (overshoot)	<25 ms
Instant operating time	
Start time and instant operating time (trip): IM/ISET ratio > 3 IM/ISET ratio = 1.05...3	<35 ms (typically 25 ms) <50 ms
Reset	
Reset ratio	97 % of the pick-up setting value
Reset time setting	0.01...10.00 s
Reset time inaccuracy	±1.0 % or ±50 ms
Instant reset time and start-up reset	<50 ms

Railway non-directional overcurrent protection (50/51)	
Measurement inputs	
Current inputs	Phase current inputs: I_A, I_B, I_C
Current input magnitudes	RMS phase currents TRMS phase currents Peak-to-peak phase currents
Current input operating frequencies	Current fundamental frequency (16.67 Hz) Current 3rd harmonic (50 Hz)
Pick-up	
Pick-up current setting	0.10...50.00 × IN 0.10...50.00 %IFUND
Inaccuracy: Current 3rd harmonic	±0.5 %ISET or ±15 mA (0.10...4.00 × ISET) ±2.0 %ISET or ±25 mA (0.10...4.00 × ISET)
Operating time	
Definite time function operating time setting	0...1,800 s
Inaccuracy: Definite time: IM/ISET ratio > 3 Definite time: IM/ISET ratio = 1.05...3	±1.0 % or ±30 ms ±1.0 % or ±70 ms
IDMT setting parameters: K (time dial setting for IDMT) A (IDMT constant) B (IDMT constant) C (IDMT constant)	0.01...25.00 0...250 0...5 0...250
Inaccuracy: IDMT operating time IDMT minimum operating time	±1.5 % or ±20 ms ±20 ms
Instant operating time	
Start time and instant operating time (trip): IM/ISET ratio > 3 IM/ISET ratio = 1.05...3	<65 ms (typically 55 ms) <90 ms
Reset	
Reset ratio	97 % of the pick-up setting value
Reset time setting	0.01...10.00 s
Reset time inaccuracy	±1.0 % or ±85 ms
Instant reset time and start-up reset	<85 ms

Railway voltage protection (27/59)	
Measurement inputs	
Voltage inputs	U1, U2, U3, or U4 voltage channel
Voltage input magnitudes	Voltage fundamental frequency (16.67 Hz) Voltage 3rd harmonic (50 Hz)
Pick-up	
Pick-up terms	1 voltage (> or <)
Pick-up setting	0.10...150.00 %UN
Inaccuracy (U > 50 V): Voltage 3rd harmonic	±1.5 %USET ±1.5 %USET
Inaccuracy (U = 20...50 V): Voltage 3rd harmonic	±3.0 %USET or 500 mV ±3.0 %USET or 500 mV

Railway directional overcurrent protection (67)	
Measurement inputs	
Current inputs	Phase current inputs: I_A, I_B, I_C Residual current channel I_{01} (coarse) Residual current channel I_{02} (fine)
Current input magnitudes	Current fundamental frequency (16.67 Hz) Current 3rd harmonic (50 Hz)
Voltage inputs	U1, U2, U3, or U4 voltage channel
Voltage input magnitudes	Voltage fundamental frequency (16.67 Hz) Voltage 3rd harmonic (50 Hz)
Pick-up	
Characteristic direction	Non-directional Directional sector Directional $I_x \cos$ Directional $I_x \sin$
Operating sector center	-180...180°
Operating sector size (+/-)	1...170°
Pick-up current setting	0.10...40.00 × IN
Inaccuracy: Current 3rd harmonic U1/I1 angle (U > 15 V) U1/I1 angle (U = 1...15 V)	±0.5 %ISET or ±15 mA (0.10...4.00 × ISET) ±2.0 %ISET or ±25 mA (0.10...4.00 × ISET) ±0.3° ±1.5°
Operating time	
Definite time function operating time setting	0...1,800 s
Inaccuracy: Definite time: IM/ISET ratio > 3 Definite time: IM/ISET ratio = 1.05...3	±1.0 % or ±30 ms ±1.0 % or ±70 ms
IDMT setting parameters: K (time dial setting for IDMT) A (IDMT constant) B (IDMT constant) C (IDMT constant)	0.01...25.00 0...250 0...5 0...250
Inaccuracy: IDMT operating time IDMT minimum operating time	±1.5 % or ±20 ms ±20 ms
Instant operating time	
Start time and instant operating time (trip): IM/ISET ratio > 3 IM/ISET ratio = 1.05...3	<65 ms (typically 55 ms) <90 ms
Reset	
Reset ratio	97 % of the pick-up setting value
Reset time setting	0.01...10.00 s
Reset time inaccuracy	±1.0 % or ±85 ms
Instant reset time and start-up reset	<85 ms

Railway voltage protection (27/59)	
Measurement inputs	
Voltage inputs	U1, U2, U3, or U4 voltage channel
Voltage input magnitudes	Voltage fundamental frequency (16.67 Hz) Voltage 3rd harmonic (50 Hz)
Pick-up	
Pick-up terms	1 voltage (> or <)
Pick-up setting	0.10...150.00 %UN
Inaccuracy (U > 50 V): Voltage 3rd harmonic	±1.5 %USET ±1.5 %USET
Inaccuracy (U = 20...50 V): Voltage 3rd harmonic	±3.0 %USET or 500 mV ±3.0 %USET or 500 mV

Operating time	
Definite time function operating time setting	0...1,800 s
Inaccuracy: Definite time: UM/USET ratio 1.05→	±1.0 % or ±70 ms
IDMT setting parameters: K (time dial setting for IDMT) A (IDMT constant) B (IDMT constant) C (IDMT constant)	0.01...25.00 0...250 0...5 0...250
Inaccuracy: IDMT operating time IDMT minimum operating time	±1.5 % or ±20 ms ±20 ms
Instant operating time	
Start time and instant operating time (trip): UM/USET ratio > 1.05→	<85 ms
Reset	
Reset ratio	97 % or 103 % of the pick-up setting value
Reset time setting	0.01...10.00 s
Reset time inaccuracy	±1.0 % or ±85 ms
Instant reset time and start-up reset	<85 ms

Motor start protection, Locked motor monitoring (48/14)	
Measurement inputs	
Current inputs	Phase current inputs: I_A, I_B, I_C
Current input magnitudes	RMS phase currents
Pick-up	
Pick-up setting	0.10...40.00 × IN
Current inaccuracy	±0.5 % ISET or ±150 mA (0.10...40.00 × ISET)
Time settings	
Starting time setting	0...1,800 s
Operating modes	Definite time or cumulative I2t sum inverse operating time With or without a speed switch input Monitors only starts or monitors both starts and stall
Start time	Max. 5 ms from the detected start up or locked rotor situation
Starting inaccuracy	±3 % of pick-up setting value > 0.5 × IN < 0.5 × IN setting
Definite time operating time inaccuracy	±0.5 % or ±10 ms
Operating time	
Definite time function operating time setting	0...1,800 s
Cumulative I2t sum inverse operating time setting	0...1,800 s
Inaccuracy: Definite time: IM/ISET ratio 1.05→	±1.0 % or ±40 ms
Instant operating time	
Start time and instant operating time (trip): IM/ISET ratio > 1.05→	<55 ms
Reset	
Reset ratio	97 % of the pick-up setting value
Reset time setting	0.01...150.00 s
Reset time inaccuracy	±1.0 % or ±35 ms
Instant reset time and start-up reset	<55 ms

Frequent start protection (66)	
Inputs	
Input magnitudes	Motor start monitor set start signals
Dependent on the motor thermal status	Yes
Settings	
Starts when cold	1...100 starts
Starts when hot	1...100 starts
Output data	
Monitor data	Used starts Available starts Alarms, inhibits, blocks Inhibit, alarm time on Time since last start
Operation	
Start time	Max. 5 ms from the detected start-up
Inaccuracy	
Starting	±3 % of the pick-up setting value > 0.5 × ISET setting (from the motor start / Locked rotor monitoring function)
Definite time operating time	±0.5 or ±10 ms of the counter deduct

Non-directional undercurrent protection (37)	
Measurement inputs	
Current inputs	Phase current inputs: I_A, I_B, I_C
Current input magnitudes	RMS phase currents
Pick-up	
Pick-up current setting	0.10...40.00 × IN
Current inaccuracy	±0.5 % ISET or ±15 mA (0.10...40.00 × ISET)
Operating time	
Definite time function operating time setting	0...1,800 s
Inaccuracy: Definite time: IM/ISET ratio 0.95	±1.0 % or ±30 ms
Instant operating time	
Start time and instant operating time (trip): IM/ISET ratio < 0.95	<50 ms
Reset	
Reset ratio	103 % of the pick-up setting value
Reset time setting	0.01...150.00 s
Reset time inaccuracy	±1.0 % or ±35 ms
Instant reset time and start-up reset	<50 ms

Mechanical jam protection (51M)	
Measurement inputs	
Current inputs	Phase current inputs: I_A, I_B, I_C
Current input magnitudes	RMS phase currents
Pick-up	
Pick-up current setting	0.10...40.00 × IN
Current inaccuracy	±0.5 % ISET or ±15 mA (0.10...40.00 × ISET)
Operating time	
Definite time function operating time setting	0...1,800 s
Inaccuracy: Definite time: IM/ISET ratio 0.95	±1.0 % or ±30 ms

Instant operating time	
Start time and instant operating time (trip): IM/ISET ratio < 0.95	<50 ms
Reset	
Reset ratio	97 % of the pick-up setting value
Reset time setting	0.01...150.00 s
Reset time inaccuracy	±1.0 % or ±35 ms
Instant reset time and start-up reset	<50 ms

Power factor protection (55)	
Measurement inputs	
Current inputs	Phase current inputs: I_A, I_B, I_C
Voltage inputs	Phase voltage inputs: V_A, V_B, V_C Phase-to-phase voltage inputs: V_{AB}, V_{BC}, V_{CA} Residual voltage input: V_0
Calculated measurement	Three-phase power factor
Pick-up	
Pick-up setting	0.00...0.99
Power factor inaccuracy (when U > 1.0 V and I > 0.1 A)	±0.001
Operating time	
Definite time function operating time setting	0...1,800 s
Inaccuracy: Definite time (at least 0.01 below the setting value)	±1.0 % or ±30 ms
Instant operating time	
Start time and instant operating time (trip): At least 0.01 below the setting value	<50 ms
Reset	
Reset ratio	1.03 of the power factor setting value
Instant reset time and start-up reset	<50 ms

Machine thermal overload protection (49M)	
Measurement inputs	
Current inputs	Phase current inputs: I_A, I_B, I_C
Current input magnitudes	TRMS phase currents (up to the 31st harmonic)
Pick-up (heating)	
NPS bias factor (unbalance effect)	0.10...10.00
Pick-up current setting	0.10...40.00 × IN
Thermal alarm and trip level setting range	0...150 %
Motor service factor	0.01...5.00 × IN
Cold condition: Long heating time constant (cold) Short heating time constant (cold)	0...500 min 0...500 min
Hot condition: Long heating time constant (hot) Short heating time constant (hot) Hot condition theta limit (cold → hot spot)	0...500 min 0...500 min 0...100 %
Reset (cooling)	
Reset ratio (pick-up and alarms)	99 %
Stop condition: Long cooling time constant (stop) Short cooling time constant (stop) Short cooling time in use	0...500 min 0...500 min 0...3,000 min
Run condition: Long cooling time constant (stop)	0...500 min
Operating time	

Definite time function operating time setting	0...3,600 s
Pick-up and reset inaccuracy	±1.0 % or ±500 ms
Environmental settings	
Thermal replica temperature estimates (selectable)	Degrees Celsius (°C) or degrees Fahrenheit (°F)
Ambient temperature effect	Linear or manually set curve
k range	0.01...5.00 × IN
Ambient temperature range	-60...+500 deg
Thermal model biasing (ambient): Set ambient temperature RTD	- 60...+500 deg Used measured ambient value

Underexcitation protection (40)	
Measurement inputs	
Current inputs	Phase current inputs: I_A, I_B, I_C
Voltage inputs	Phase voltage inputs: V_A, V_B, V_C Phase-to-phase voltage inputs: V_{AB}, V_{BC}, V_{CA} Residual voltage input: V_0
Calculated measurements	Three-phase reactive power
Pick-up	
Pick-up setting	-106...1 kVar
Reactive power inaccuracy	Typically <1.0 % QSET
Operating time	
Definite time function operating time setting	0...1,800 s
Inaccuracy: Definite time QM/QSET ratio 1.05→	±1.0 % or ±35 ms
Instant operating time	
Start time and instant operating time (trip): QM/QSET ratio < 0.95	<50 ms
Reset	
Reset ratio	97 % of the pick-up setting value
Reset time setting	0...150 s
Reset time inaccuracy	±1.0 % or ±35 ms
Instant reset time and start-up reset	<50 ms

Underimpedance protection (21U)	
Measurement inputs	
Current inputs	Phase current inputs: I_A, I_B, I_C
Voltage inputs	Phase voltage inputs: V_A, V_B, V_C Phase-to-phase voltage inputs: V_{AB}, V_{BC}, V_{CA} Residual voltage input: V_0
Calculated impedances	Phase-to-phase impedances Phase-to-ground impedances Positive sequence impedance
Pick-up	
Pick-up setting	0.10...150.00 Ω
Impedance calculation inaccuracy	Typically <1.0 % ZSET
Operating time	
Definite time function operating time setting	0...1,800 s
Inaccuracy: Definite time ZM/ZSET ratio < 0.95	±1.0 % or ±25 ms
Instant operating time	

Start time and instant operating time (trip): ZM/ZSET ratio <0.95	<45 ms
Reset	
Reset ratio	103 %ZSET
Reset time setting	0.01...150.00 s
Reset time inaccuracy	±1.0 % or ±25 ms
Instant reset time and start-up reset	<45 ms

Underreactance protection (21/40)

Measurement inputs	
Current inputs	Phase current inputs: I_A, I_B, I_C
Voltage inputs	Phase voltage inputs: V_A, V_B, V_C Phase-to-phase voltage inputs: V_{AB}, V_{BC}, V_{CA} Residual voltage input: V_0
Calculated impedances	Phase-to-phase impedances Phase-to-ground impedances Positive sequence impedance

Pick-up	
Pick-up settings:	
X circle offset	-50...50 k Ω
RX circle radius	0.01 Ω ...50 k Ω
Calculation inaccuracy	Typically <1.0 %XSET

Operating time	
Definite time function operating time setting	0...1,800 s
Inaccuracy: Definite time XM/XSET ratio <0.95	±1.0 % or ±30 ms

Instant operating time	
Start time and instant operating time (trip): XM/XSET ratio <0.95	<60 ms

Reset	
Reset ratio	103 %XSET
Reset time setting	0.01...150.00 s
Reset time inaccuracy	±1.0 % or ±30 ms
Instant reset time and start-up reset	<45 ms

100 % stator ground fault protection (645)

Measurement inputs	
Current inputs	Phase current inputs: I_A, I_B, I_C
Current input calculation	Positive sequence current (I1)
Voltage inputs	Residual voltage from U3 or U4 voltage channel
Voltage input magnitude	Zero sequence voltage 3rd harmonic

Pick-up	
Pick-up setting	1...95 % V_0N
V_0 3rd harmonic inaccuracy	±1.0 % V_0 SET or ±100 mA (0.10...4.00 \times IN)

Low-voltage blocking	
"No load" current setting	0.00...1.00 \times IN
Starting inaccuracy (I1)	±1.0 %ISET or ±100 mA (0.10...4.00 \times IN)

Operating time	
Definite time function operating time setting	0...1,800 s
Inaccuracy: Definite time IM/ISET ratio 0.95	±1.0 % or ±30 ms

Instant operating time	
Start time and instant operating time (trip): UM/USET ratio <0.95	<60 ms

Reset	
Reset ratio	103 % of the pick-up setting value
Reset time setting	0.01...150.00 s
Reset time inaccuracy	±1.0 % or ±30 ms
Instant reset time and start-up reset	<45 ms

Voltage-restrained overcurrent protection (51V)

Measurement inputs	
Current inputs	Phase current inputs: I_A, I_B, I_C
Current input magnitudes	RMS phase currents
Voltage inputs	Phase voltage inputs: V_A, V_B, V_C Phase-to-phase voltage inputs: V_{AB}, V_{BC}, V_{CA} Residual voltage input: V_0
Voltage input calculation	Positive sequence voltage

Pick-up	
Pick-up current setting (Point 1 & 2)	0.10...40.00 \times IN
Pick-up voltage setting (Point 1 & 2)	0.05...150.00 %UN
Inaccuracy: Current Voltage	±0.5 %ISET or ±15 mA (0.10...4.00 \times IN) ±1.5 %USET or ±30 mV

Operating time	
Definite time function operating time setting	0...1,800 s
Inaccuracy: Definite time IM/ISET ratio 1.05→	±1.0 % or ±25 ms
IDMT setting parameters: K (time dial setting for IDMT) A (IDMT constant) B (IDMT constant) C (IDMT constant)	0.01...25.00 0...250 0...5 0...250
Inaccuracy: IDMT operating time IDMT minimum operating time	±1.5 % or ±20 ms ±20 ms

Instant operating time	
Start time and instant operating time (trip): IM/ISET ratio 1.05→	<40 ms

Reset	
Current reset ratio	97 % of the pick-up setting value
Reset time setting	0.01...150.00 s
Reset time inaccuracy	±1.0 % or ±25 ms
Instant reset time and start-up reset	<45 ms

Volts-per-hertz overexcitation protection (24)

Measurement inputs	
Voltage inputs	Phase voltage inputs: V_A, V_B, V_C Phase-to-phase voltage inputs: V_{AB}, V_{BC}, V_{CA}
Voltage input magnitude	Maximum line-to-line voltage
Frequency references: Reference 1 Reference 2 Reference 3	CT1L1, CT2L1, VT1U1, VT2U1 CT1L2, CT2L2, VT1U2, VT2U2 CT1L3, CT2L3, VT1U3, VT2U3
Pick-up	
Pick-up setting	0.01...75.00 %
V/Hz inaccuracy	±1.0 %

Operating time	
Definite time function operating time setting	0...1,800 s
Inaccuracy: Definite time VHZM/VHZSET ratio 1.05	±1.0 % or ±25 ms

Instant operating time	
Start time and instant operating time (trip): VHZM/VHZSET ratio 1.05	<40 ms

Reset	
Reset ratio	97 % of the pick-up setting value
Reset time setting	0.01...150.00 s
Reset time inaccuracy	±1.0 % or ±25 ms
Instant reset time and start-up reset	<40 ms

Pole slip protection (78)

Input signals	
Current input magnitudes	Phase current RMS
Voltage input magnitudes	Phase-to-ground voltage RMS Phase-to-phase voltage RMS Residual voltage RMS (calculated phase-to-ground voltage)
Suitable voltage measurement modes	
Voltage measurement modes	3LN + U4 3LL + U4 (when U4 is used as V_0) 2LL + U3 + U4 (when either U3 or U4 is used as V_0) 3LN (LEA req. HW)

Pick-up	
Characteristic (lens) settings: Forward reactive reach (XFWD) Reverse reactive reach (XREV) Resistive reach (RFWD) Lens inclination (α)	-0.20...-25.00 Ω 0.20...25.00 Ω 0.20...25.00 Ω 90...45°
Zone1/Zone2 (slip center detection): System side swing reach (SFWD)	20...100 %XFWD
Inaccuracy: Impedance Angle Angle ($U = 1...15$ V)	±5.0 %ZSET (typically) ±0.15° ±1.5°

Timers	
Slip timers: State transition time (dZ/dt) Max. slip time	0.02...0.20 s 0.10...60.00 s
Inaccuracy: Definite time	±1.0 % or ±20 ms

Number of slips	
Number of slips to trip	1...10

Reset	
Impedance reset ratio	103 % of the pick-up setting value
Instant reset time and start-up reset	<50 ms

Line thermal overload protection (49F)

Input signals	
Current inputs	Phase current inputs: I_A, I_B, I_C
Current input magnitudes	TRMS phase currents (up to the 31st harmonic)

Settings	
Time constants τ	1
Time constant value	0...500 min
Service factor (maximum overloading)	0.01...5.00 \times IN
Thermal model biasing	Ambient temperature (set -60...500°) Negative sequence current
Thermal replica temperature estimates (selectable)	Degrees Celsius (°C) or degrees Fahrenheit (°F)

Outputs	
Alarm 1	0...150 %
Alarm 2	0...150 %
Thermal trip	0...150 %
Trip delay	0...3,600 s
Restart inhibit	0...150 %
Inaccuracy	
Starting	±0.5 of the pick-up setting value
Operating time	±5.0 % or ±500 ms

Transformer status monitoring (TST)

Features	
Control scale	Common transformer data settings for all functions in the transformer module, the protection logic, the HMI, and the I/O
Settings	Transformer application nominal data
Other features	Status hours counters (normal load, high overload) Transformer status signals Transformer data for functions

Outputs	
Light/no load	IM <0.2 \times IN
Inrush HV side	IM <0.2 \times IN → IM >1.3 \times IN
Inrush LV side	IM <0.2 \times IN → IM >1.3 \times IN
Load normal	IM >0.2 \times IN → IM <1.0 \times IN
Overloading	IM >1.0 \times IN ... <1.3 \times IN
High overload	IM >1.3 \times IN
Inaccuracy	
Current detection	±3 % of the pick-up setting value > 0.5 \times IN 5 mA \times IN < 0.5 \times IN
Detection time	±0.5 % or ±10 ms

Transformer thermal overload protection (49T)

Input signals	
Current inputs	Phase current inputs: I_A, I_B, I_C
Current input magnitudes	TRMS phase currents (up to the 31st harmonic)

Setting specifications	
Time constants τ	1 heating, 1 cooling
Time constant value	0...500 min
Service factor (maximum overloading)	0.01...5.00 \times IN
Thermal model biasing	Ambient temperature (set -60...500°) Negative sequence current
Thermal replica temperature estimates (selectable)	Degrees Celsius (°C) or degrees Fahrenheit (°F)

Outputs	
Alarm 1	0...150 %
Alarm 2	0...150 %
Thermal trip	0...150 %
Trip delay	0...3,600 s
Restart inhibit	0...150 %
Inaccuracy	
Starting	±0.5 of the pick-up setting value
Operating time	±5.0 % or ±500 ms

Resistance temperature detectors (RTD)	
Inputs	
Resistance input magnitudes	Measured temperatures measured by RTD sensors
RTD channels	12 individual RTD channels
Settable alarms	24 alarms (2 per RTD channel)
Pick-up	
Alarm setting range	101...2,000° (either < or > setting)
Inaccuracy	±3 % of the pick-up setting value
Reset ratio	97 % of the pick-up setting value
Operating time	
Operating time	Typically <500 ms

Arc fault protection (50Arc/51Narc)	
Measurement inputs	
Current inputs	Phase current inputs: I_A, I_B, I_C Residual current channel I_{01} (coarse) Residual current channel I_{02} (fine)
Current input magnitudes	Sample-based phase current measurement Sample-based residual current measurement
Arc point sensor inputs	Channels S1, S2, S3, S4 (light only sensors, pressure, and light sensor) Up to 4 sensors per channel
System frequency operating range	6...75 Hz
Pick-up	
Pick-up current settings: Phase currents Residual current	0.50...40.00 × IN 0.10...40.00 × IN
Pick-up light intensity selections	8 klx 25 klx 50 klx
Starting inaccuracy	±3 % of the pick-up setting value > 0.5 × IN 5 mA × IN < 0.5 × IN
Point sensor detection radius	180°
Instant operating time	
Light only: Semiconductor outputs HS01 and HS02 Regular relay outputs	Typically 7 ms (3...12 ms) Typically 10 ms (6.5...15 ms)
Light and current criteria (zone 1...4): Semiconductor outputs HS01 and HS02 Regular relay outputs	Typically 10 ms (6.5...15 ms) Typically 14 ms (10...18 ms)
Arc BI only: Semiconductor outputs HS01 and HS02 Regular relay outputs	Typically 7 ms (2...12 ms) Typically 10 ms (6.5...15 ms)

Voltage memory	
Measurement inputs	
Voltage inputs	Phase voltage inputs: V_A, V_B, V_C Phase-to-phase voltage inputs: V_{AB}, V_{BC}, V_{CA} Residual voltage input: V_0
Current inputs (back-up frequency)	Phase current inputs: I_A, I_B, I_C
Pick-up	
Pick-up voltage setting	2.00...50.00 %UN
Pick-up current setting (optional)	0.01...50.00 × IN
Inaccuracy: Voltage Current	±1.5 %USET or ±30 mV ±0.5 %ISET or ±15 mA (0.10...4.00 × ISET)

Operating time	
Angle memory activation delay	<20 ms (typically 5 ms)
Maximum active time	0.02...50.00 s
Inaccuracy: Definite time UM/USET ratio >1.05	±1.0 % or ±35 ms
Angle memory	
Angle drift while voltage is absent	±1.0° per 1 second
Reset	
Reset ratios: Voltage memory (voltage) Voltage memory (current)	103 % of the pick-up voltage setting value 97 % of the pick-up voltage setting value
Reset time	<50 ms

Control functions

Setting group selection	
Setting and control modes	
Setting groups	8 independent, control-prioritized setting groups
Control scale	Common for all installed functions which support setting groups
Control mode	
Local	Any digital signal available in the device
Remote	Force change override of local controls either from the setting tool, HMI, or SCADA
Operating time	
Reaction time	<5 ms from receiving the control signal

Object control and monitoring (OBJ), Single-pole object control and monitoring (OBS)	
General	
Number of objects	1 5 10
Supported object types	Circuit breaker Circuit breaker with withdrawable cart Disconnecter (MC) Disconnecter (GND) Custom object image (AQ 250 only)
Signals	
Input signals	Digital inputs Software signals
Output signals	CLOSE command output OPEN command output
Operating time	
Breaker traverse time setting	0.02...500.00 s
Max. CLOSE/OPEN command pulse length	0.02...500.00 s
Control termination time-out setting	0.02...500.00 s
Inaccuracy: Definite time operating time	±0.5 % or ±10 ms
Breaker control operating time	
External object control time	<75 ms
Object control during auto-reclosing	(see the technical sheet for the auto-reclosing function)

Indicator object monitoring (IND)	
General	
Number of objects	5 10 20
Supported object types	Disconnecter (GND) Custom object image (AQ 250 only)
Signals	
Input signals	Digital inputs Software signals

Cold load pick-up (CLPU)	
Measurement inputs	
Current inputs	Phase current inputs: I_A, I_B, I_C
Current input magnitudes	RMS phase currents
Pick-up	
Pick-up current setting: ILOW/IHIGH/IOVER	0.01...40.00 × IN
Reset ratio	97 % of the pick-up setting value
Current inaccuracy	±0.5 %ISET or ±15 mA (0.10...4.00 × ISET)
Operating time	
Definite time function operating time settings: tSET tMAX tMIN	0...1,800 s 0...1,800 s 0...1,800 s
Inaccuracy: Definite time IM/ISET ratio = 1.05/0.95	±1.0 % or ±45 ms
Instant operation time	
CLPU activation and release	<45 ms (measured from the trip contact)

Switch-on-to-fault (SOTF)	
Initialization signals	
SOTF activate input	Any blocking input signal (Object closed signal, etc.)
Pick-up	
SOTF function input	Any blocking input signal (I> or similar)
SOTF activation time	
Activation time	<40 ms (measured from the trip contact)
SOTF release time	
Release time setting	0...1,800 s
Definite time inaccuracy	±1.0 % or ±30 ms
SOTF instant release time	<40 ms (measured from the trip contact)

Synchrocheck ($\Delta V/\Delta\alpha/\Delta f$)	
Input signals	
Voltage inputs	U1, U2, U3, or U4 voltage channel
Voltage input magnitudes	RMS line-to-line or line-to-neutral voltages U3 or U4 voltage channel RMS
Pick-up	
U diff < setting	2...50 %UN
Freq diff < setting	0.05...0.50 Hz
Angle diff < setting	3...90°
Inaccuracy: Voltage Frequency Angle	±3.0 %USET or ±0.3 %UN ±25 mHz (U> 30 V secondary) ±1.5° (U> 30 V secondary)

Reset	
Inaccuracy: Voltage Frequency Angle	99 % of the pick-up voltage setting value 20 mHz ±2.0°
Activation time	
Activation (to LD/DL/DD)	<35 ms
Activation (to Live Live)	<60 ms
Reset	<40 ms
Bypass modes	
Voltage check modes (excluding LL)	LL+LD LL+DL LL+DD LL+LD+DL LL+LD+DD Bypass
U live > limit	0.10...100.00 %UN
U dead < limit	0...100 %UN

Vector jump (78)	
Measurement inputs	
Voltage inputs	Phase voltage inputs: V_A, V_B, V_C Phase-to-phase voltage inputs: V_{AB}, V_{BC}, V_{CA} Residual voltage input: V_0
Monitored voltages	Any or all system line-to-line voltage(s) Any or all system line-to-neutral voltage(s) Selected line-to-line or line-to-neutral voltage U4 channel voltage
Pick-up	
Pick-up setting	0.05...30.00°
Voltage inaccuracy	±30 % overreach or 1.00°
Low-voltage blocking	
Pick-up setting	0.01...100.00 %UN
Voltage inaccuracy	±1.5 %USET or 30 mV
Instant operating time	
Alarm and trip operating time: IM/ISET ratio > ±30 % overreach or 1.00°	<40 ms (typically 30 ms) (50/60 Hz) <50 ms (typically 40 ms) (16.67 Hz)
Reset	
Trip pulse	Appr. 5...10 ms

Automatic voltage regulator (90)	
Measurement inputs	
Voltage inputs	Phase voltage inputs: V_A, V_B, V_C Phase-to-phase voltage inputs: V_{AB}, V_{BC}, V_{CA} Residual voltage input: V_0
Voltage input magnitudes	RMS line-to-line voltages U4 channel RMS voltage
Current inputs	Phase current inputs: I_A, I_B, I_C
Current input magnitudes (I> blocking)	RMS phase currents
Pick-up	
Pick-up area (U>/<)	0.01...30.00 %UN
Tap step effect (1...70 steps)	0.01...10.00 %UN
I> blocking	0...40.00 × IN
Inaccuracy: Voltage Current	±1.5 %USET ±0.5 %ISET or ±15 mA (0.10...4.00 × ISET)

Operating time	
Control pulse min/max and time between	0...1,800 s
Definite time function operating time setting	0...1,800 s
Inaccuracy: Definite time UM/USET ratio 1.05→	±1.5 % or ±50 ms
Integrated operating time setting: Multiplier (k)	0...1,800
Inaccuracy: IDMT operating time IDMT minimum operating time	±1.5 % or ±35 ms ±20 ms
Instant operating time	
Start time and instant operating time (trip): UM/USET ratio 1.05→	<50 ms
Reset	
Reset ratio: Voltage Current	95 % or 105 % of the pick-up voltage setting value 97 % of the pick-up current setting value
Reset time setting	0.01...10.00 s
Reset time inaccuracy	±1.0 % or ±35 ms
Instant reset time and start-up reset	<50 ms

Auto-recloser (79)	
Input signals	
Input signals	Software signals (protection, logics, etc.) Binary inputs
Requests	
REQ1-5	5 priority request inputs (can be set parallel as signals to each request)
Shots	
1-5 shots	5 independent or scheme-controlled shots in each AQ request
Operating time	
Operating time settings: Lockout after successful AR Object close reclaim time AR shot starting delay AR shot dead time delay AR shot action time AR shot specific reclaim time	0...1,800 s 0...1,800 s 0...1,800 s 0...1,800 s 0...1,800 s 0...1,800 s
Inaccuracy	
AR starting (from a protection stage's START signal)	±1.0 % or ±30 ms (AR delay)
AR starting (from a protection stage's TRIP signal)	Trip delay inaccuracy +25 ms (protection + AR delay)
Dead time	±1.0 % or ±35 ms (AR delay)
Action time	±1.0 % or ±30 ms (AR delay)
Instant starting time	
Instant operating time	Protection activation delay + 15 ms (protection + AR delay)

Zero sequence recloser (79N)	
Measurement inputs	
Voltage input	Residual voltage from the U4 voltage channel
Voltage input magnitude	RMS residual voltage (V_0)
Reset	
Reset time setting	0...150 s
Reset time inaccuracy	±1.0 % or ±35 ms

Excitation control	
Control modes	
Automatic voltage regulator (AVR)	
Field current regulator (FCR)	
Reactive power controller (MVAR)	
Power factor controller (PF)	
Excitation limiters	
Underexcitation limiter (UEL)	
Stator current limiter (SCL)	
Volts-per-hertz limiter (VHSL)	
Instant field current limiter (IFCL)	
Delayed field current limiter (DFCL)	
Others	
Voltage supervision (SUP)	
Power system stabilizer (PSS)	

Monitoring functions

Current transformer supervision (CTS)	
Measurement inputs	
Current inputs	Phase current inputs: I_A, I_B, I_C Residual current channel I_{01} (coarse) Residual current channel I_{02} (fine)
Current input magnitudes	RMS phase currents RMS residual currents
Pick-up	
Pick-up current settings: ISET high limit ISET low limit ISUM difference ISET ratio I2/I1 ratio	0.10...40.00 × IN 0.10...40.00 × IN 0.10...40.00 × IN 0.01...100.00 % 0.01...100.00 %
Inaccuracy: Starting I_A, I_B, I_C Starting I2/I1	±0.5 % ISET or ±15 mA (0.10...4.00 × ISET) ±1.0 % I2SET/I1SET or ±100 mA (0.10...4.00 × IN)
Starting I_{01} (1 A)	±0.5 % I0SET or ±3 mA (0.005...10.000 × ISET)
Starting I_{02} (0.2 A)	±1.5 % I0SET or ±1.0 mA (0.005...25.000 × ISET)
Time delay for alarm	
Definite time function operating time setting	0...1,800 s
Inaccuracy: Definite time IM/ISET ratio > 1.05	±2.0 % or ±80 ms
Instant operation time (alarm): IM/ISET ratio > 1.05	<80 ms (<50 ms in differential protection devices)
Reset	
Reset ratio	97 % or 103 % of the pick-up setting value
Instant reset time and start-up reset	<80 ms (<50 ms in differential protection devices)

Voltage transformer supervision (VTS)	
Measurement inputs	
Voltage inputs	Phase voltage inputs: V_A, V_B, V_C Phase-to-phase voltage inputs: V_{AB}, V_{BC} (AQ-F213x) Phase-to-phase voltage inputs: V_{AB}, V_{BC}, V_{CA} (others)
Voltage input magnitudes	RMS line-to-line or line-to-neutral voltages

Pick-up	
Pick-up current settings: Voltage (low pick-up) Voltage (high pick-up) Angle shift limit	0.05...0.50 × UN 0.50...1.10 × UN 2...90°
Inaccuracy (AQ-F213x): Voltage U angle (U > 1 V)	±4.0 % USET ±3.0°
Inaccuracy (others): Voltage U angle (U > 1 V)	±1.5 % USET ±1.5°
External line/bus-side pick-up (optional)	0 → 1
Time delay for alarm	
Definite time function operating time setting	0...1,800 s
Inaccuracy: Definite time IM/ISET ratio > 1.05	±1.0 % or ±35 ms
Instant operation time (alarm): IM/ISET ratio > 1.05	<50 ms (AQ-F213x) <80 ms (others)
VTS MCB trip bus/line (external input)	<50 ms
Reset	
Reset ratio	97 % or 103 % of the pick-up setting value
Reset time setting	0.01...10.00 s
Reset time inaccuracy	±1.0 % or ±35 ms (AQ-F213x) ±2.0 % or ±80 ms (others)
Instant reset time and start-up reset	<50 ms
VTS MCB trip bus/line (external input)	<50 ms

Circuit breaker wear monitoring (CBW)	
Pick-up	
Breaker characteristics settings: Nominal breaking current Maximum breaking current Operations with nominal br. current Operations with maximum br. current Pick-up setting for Alarms 1 and 2	0...100 kA 0...100 kA 0...200,000 operations 0...200,000 operations 0...200,000 operations
Inaccuracy	
Inaccuracy for current/operations counter: Current measurement element	0.1 × UN > 1 < 2 × UN ±0.2 % of the measured current, rest 0.5 % ±0.5 % of operations deducted
Operation counter	

Total harmonic distortion (THD)	
Input signals	
Current inputs	Phase current inputs: I_A, I_B, I_C Residual current channel I_{01} (coarse) Residual current channel I_{02} (fine)
Current input magnitudes	Current measurement channels (FFT result) up to the 31st harmonic component
Voltage inputs	Phase voltage inputs: V_A, V_B, V_C Phase-to-phase voltage inputs: V_{AB}, V_{BC}, V_{CA} Residual voltage input: V_0
Voltage input magnitudes	Voltage measurement channels (FFT result) up to the 31st harmonic component
Pick-up	
Operating modes	Power THD Amplitude THD
Pick-up settings for all comparators	0.10...200.00 %
Inaccuracy	±3 % of the pick-up setting value > 0.5 × IN setting 5 mA < 0.5 × IN setting
Time delay	

Definite time function operating time setting for all timers	0...1,800 s
Inaccuracy: Definite time operating time Instant operating time (when IM/ISET ratio > 3) Instant operating time (when IM/ISET ratio 1.05 < IM/ISET < 3)	±0.5 % or ±10 ms Typically <20 ms Typically <25 ms
Reset	
Reset time	Typically <10 ms
Reset ratio	97 %

Fault locator (21FL)	
Input signals	
Current inputs	Phase current inputs: I_A, I_B, I_C
Voltage inputs	Phase voltage inputs: V_A, V_B, V_C Phase-to-phase voltage inputs: V_{AB}, V_{BC}, V_{CA} Residual voltage input: V_0
Calculated reactance magnitudes when line-to-neutral voltages available	XL12, XL23, XL31, XL1, XL2, XL3
Calculated reactance magnitudes when line-to-line voltages available	XL12, XL23, XL31
Pick-up	
Trigger current >	0...40 × IN
Triggering inaccuracy	±0.5 % ISET or ±15 mA (0.10...4.00 × ISET)
Reactance	
Reactance per kilometer	0...5,000 s
Reactance inaccuracy	Typically ±5.0 %
Triggering operation	
Activation	From the TRIP signal of any protection stage
Minimum operating time	At least 0.04 s of stage operation time required

Disturbance recorder	
Recorded values	
Recorder analog channels	0...20 channels Freely selectable
Recorder digital channels	0...95 channels Freely selectable analog and binary signals 5-ms sample rate (FFT)
Performance	
Sample rate	8 samples/cycle 16 samples/cycle 32 samples/cycle 64 samples/cycle
Recording length	0...1,800 s (maximum length determined by the selected signals)
Number of recordings	0...100 recordings, 60 MB of shared flash memory reserved (maximum number of recordings determined by the combination of selected signals and set operation time)

Environmental tests

Disturbance tests	
Emissions	
Conducted emissions: EN 60255-26 (Ch. 5.2), CISPR 22	150 kHz...30 MHz
Radiated emissions: EN 60255-26 (Ch. 5.1), CISPR 11	30...1,000 MHz
Immunity	
Electrostatic discharge (ESD): EN 60255-26, IEC 61000-4-2	15 kV (air discharge) 8 kV (contact discharge)
Electrical fast transients (EFT): EN 60255-26, IEC 61000-4-4	4 kV, 5/50 ns, 5 kHz (power supply input) 4 kV, 5/50 ns, 5 kHz (other inputs and outputs)
Surge: EN 60255-26, IEC 61000-4-5	2 kV, 1.2/50 μs (between wires) 4 kV, 1.2/50 μs (between wire and earth)
Radiated RF electromagnetic field: EN 60255-26, IEC 61000-4-3	f = 80...1,000 MHz, 10 V/m
Conducted RF field: EN 60255-26, IEC 61000-4-6	f = 150 kHz...80 MHz, 10 V (RMS)
Voltage tests	
Dielectric voltage test	
EN 60255-27, IEC 60255-5, EN 60255-1	2 kV, 50 Hz, 1 min
Impulse voltage test	
EN 60255-27, IEC 60255-5	5 kV, 1.2/50 μs, 0.5 J
Mechanical tests	
Vibration test	
EN 60255-1, EN 60255-27, IEC 60255-21-1 (Class 1)	2...13.2 Hz, ±3.5 mm 13.2...100 Hz, ±1.0 g
Shock and bump test	
EN 60255-1, EN 60255-27, IEC 60255-21-2 (Class 2)	20 g 1,000 bumps/direction
Environmental tests	
Damp heat (cyclic)	
EN 60255-1, IEC 60068-2-30	Operational: +25...+55 °C, 93...97 % (RH), 12+12 h
Dry heat	
EN 60255-1, IEC 60068-2-2	Storage: +70 °C, 16 h Operational: +55 °C, 16 h
Cold test	
EN 60255-1, IEC 60068-2-1	Storage: -40 °C, 16 h Operational: -20 °C, 16 h

Environmental conditions	
IP classes	
Casing protection class	IP54 (front) IP21 (rear)
Temperature ranges	
Ambient service temperature range	-35...+70 °C
Transport and storage temperature range	-40...+70 °C
Other	
Altitude	<2,000 m
Overvoltage category	III
Pollution degree	2

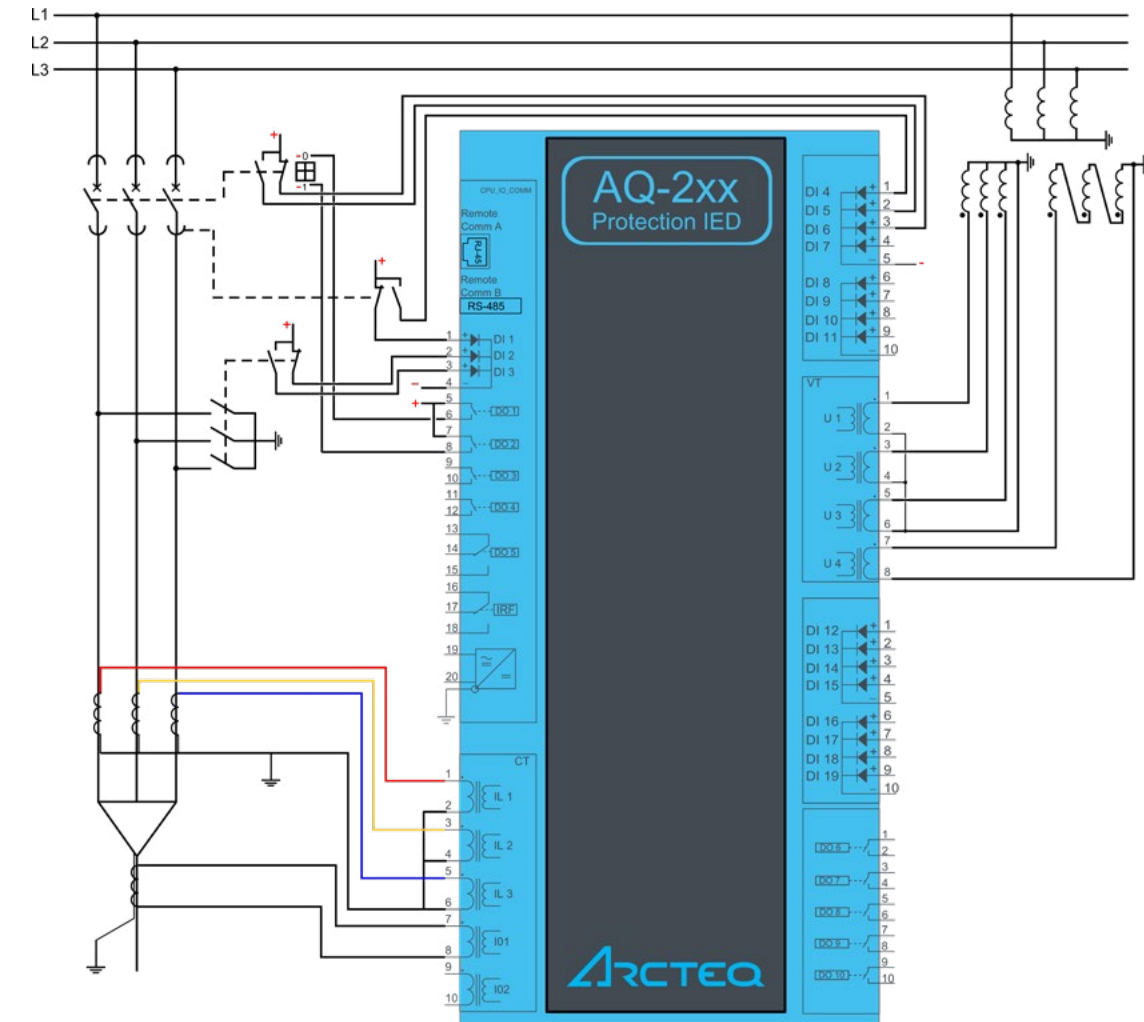

The figure above presents a typical AQ 200 series device wiring diagram as an example. The wiring includes current measurements for the three phase currents and the residual current, as well as the phase-to-neutral and residual voltage measurements. Alternative connections are also available: for example, you could have phase-to-phase voltage and

Synchrocheck reference voltage connections. With the AQtivate 200 software you can conveniently change the relevant settings, such as all analog channel measurement mode settings, polarities, and nominal values.

For more details about the wiring, please refer to the instruction manuals for specific AQ 200 series devices.

INSTALLATION AND DIMENSIONS 210

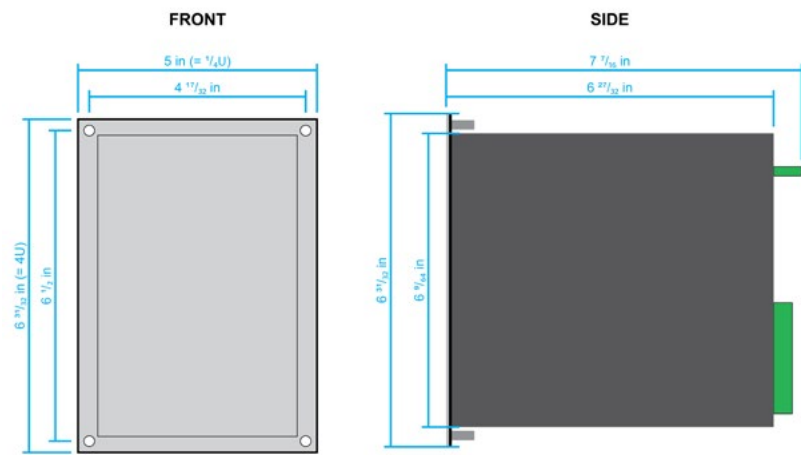

Dimensions of the AQ-21x device.

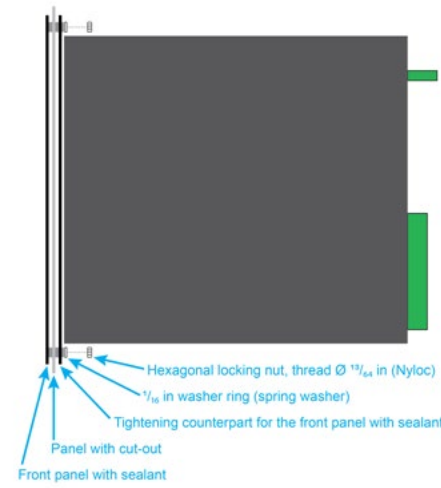

Installation of the AQ-21x device.

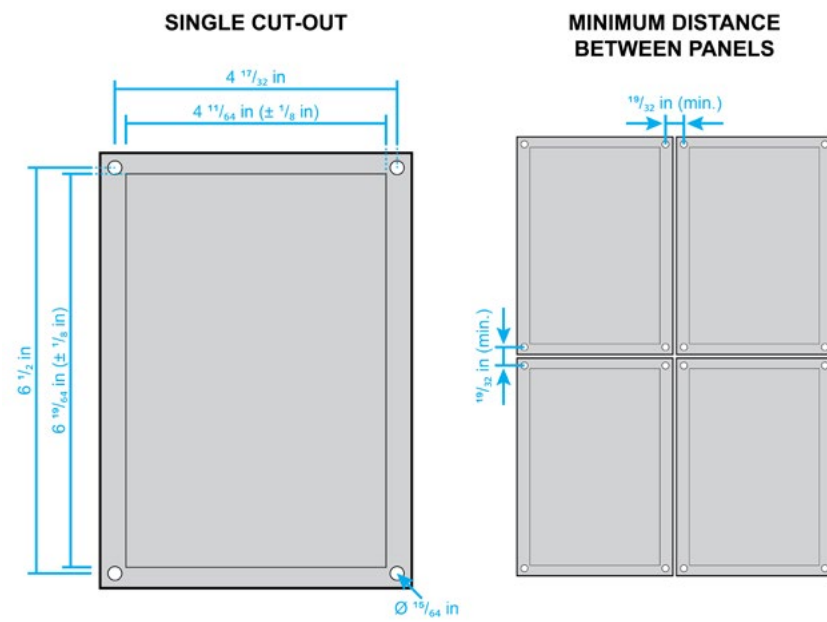

Panel cut-out and spacing of the AQ-21xx device.

INSTALLATION AND DIMENSIONS 250

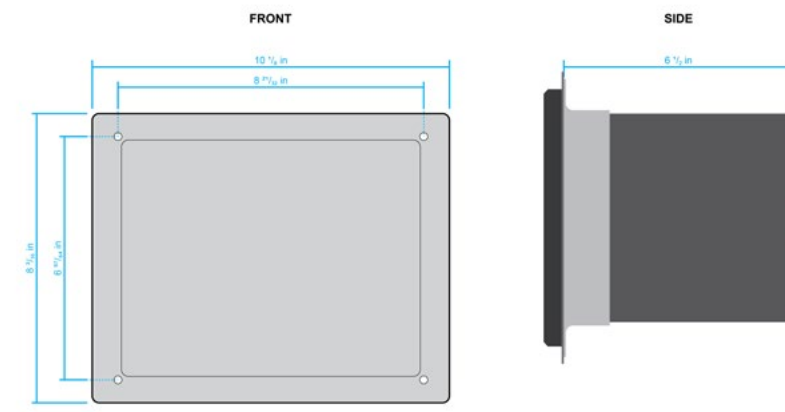

Dimensions of the AQ-25x device.

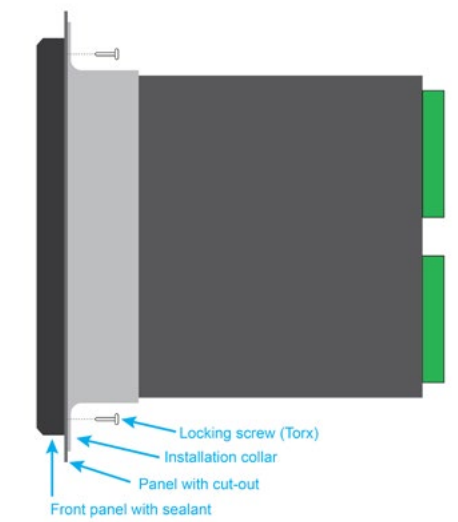

Installation of the AQ-25x device.

MINIMUM DISTANCE BETWEEN PANELS

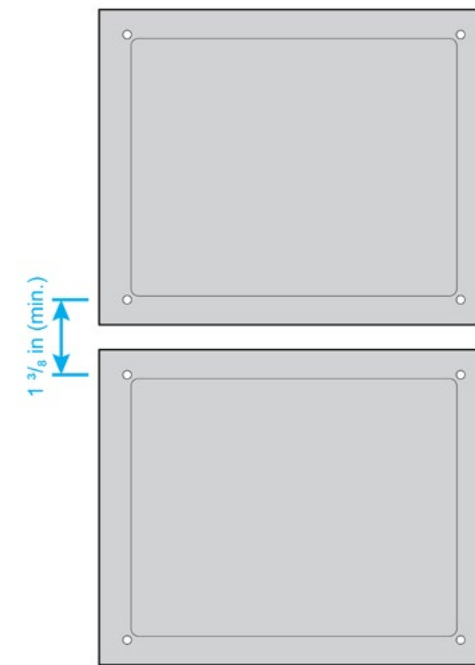

Panel cut-out and spacing of the AQ-25x device.



ENSTO NORTH AMERICA INC.

4500 S. Hardin Blvd.
Suite 460
McKinney, TX 75070, USA
tel: +1 (972) 369-7788

MAIL INQUIRIES:

Sales.US@arcteq.com

TECHNICAL SUPPORT:

arcteq.com/support

ARCTEQ SUPPORT LINE:

+358 10 3221 388
EET 9:00 - 17:00

ARCTEQ HEADQUARTERS

Arcteq Relays Ltd
Kvartsikatu 2 A 1
65300 Vaasa, Finland
Business ID: 2342569-3
tel: +358 10 3221 370



Learn about the most accurate protection relays in the world.

ARCTEQ.COM 