



AQ 100 SERIES

ARC FLASH PROTECTION

THE PIONEER IN ARC FLASH PROTECTION	3	SENSORS	31
PRODUCT OVERVIEW	4	➤ Point sensors.....	31
➤ Benefits of arc protection.....	4	➤ Fiber sensors.....	32
➤ Medium-voltage products.....	5	ACCESSORIES	33
➤ Low-voltage products.....	6	➤ Raising frame.....	33
➤ Sensors (for MV and LV).....	7	➤ Sensor mounting bracket.....	33
➤ Arc quenching devices.....	7	➤ Selection Table.....	34
ARCTEQ INNOVATIONS	8	➤ Technical data.....	36
➤ Protection for both personnel and equipment.....	8	➤ Certificates.....	37
➤ Arc quenching device that can be re-activated for multiple trips.....	9	➤ Example wiring.....	38
➤ Dedicated and dependable protection with standard arc schemes.....	10	➤ Installation and dimensions.....	39
➤ Typical standard arc scheme (LV).....	11	➤ AQ-103 & AQ-110X.....	39
➤ Typical standard arc scheme (MV).....	12	➤ AQ-101, AQ-101S & AQ-102.....	40
➤ Typical standard arc scheme for AQ-103.....	13	➤ AQ-101D.....	41
➤ Adding the pressure criterion to arc flash protection.....	14	NOTES	42
➤ Gateway in arc protection schemes.....	15		
MEDIUM-VOLTAGE	16		
➤ AQ-110P Current and point sensor unit.....	16		
➤ AQ-110F Current and fiber sensor unit.....	17		
➤ AQ-103 Point sensor unit with Modbus.....	18		
➤ AQ-101 Point sensor unit.....	19		
➤ AQ-101D Point sensor unit (DIN rail).....	20		
➤ AQ-101S Point sensor unit with extended I/O.....	21		
➤ AQ-102 Fiber sensor unit.....	22		
➤ SIQuench 3AM4132 and 3AM4143 Arc quenching devices.....	23		
LOW-VOLTAGE	24		
➤ AQ-110PLV Current and point sensor unit.....	24		
➤ AQ-110FLV Current and fiber sensor unit.....	25		
➤ AQ-103LV Point sensor unit with Modbus.....	26		
➤ AQ-101LV Point sensor unit.....	27		
➤ AQ-101DLV Point sensor unit (DIN rail).....	28		
➤ AQ-102LV Fiber sensor unit.....	29		
➤ AQ-1000 Quenching device.....	30		

THE PIONEER IN ARC FLASH PROTECTION

Our superior application know-how, continuous research, and decades of experience in product development in this field have all made Arcteq the technology leader that we are today. Our AQ 100 series is ready to provide ultimate safety both medium-voltage and low-voltage systems with the help of Arcteq’s patented technology.

Most reliable protection

The reliability of the AQ 100 series is based on our unbeatable experience in the field of arc protection. Our unique Standard Arc Schemes ensure correct operation under all conditions.

When an arc flash occurs, there is no room for mistakes.



THE WIDEST RANGE OF PRODUCTS ON THE MARKET

The AQ 100 system supports arc flash systems with a wide range of applications. The full system can be anything from a single unit covering a few cubicles of switchgear to a complex multi-incomer configuration with hundreds of units. Thanks to the unique design of the AQ 100 system, the number of arc protection units that can be connected to a system is nearly unlimited. The different available sensors support various ways of constructing an arc flash protection system: only using point sensors, only using fiber sensors, or using a mixture of the two. The AQ 100 system

always operates fast, and by adding one of our resettable quenching devices (AQ-1000 or SIQuench 3AM4132/4143) the total arcing time can be reduced to less than 5 ms. When an arc flash occurs in a system with an AQ-1000 or a SIQuench device, the source of the arc fault is removed and the power returns in minutes, or even seconds. The quenching device can repeatedly extinguish arc faults up to 100 kA, also reducing the arc flash exposure to less than 1 cal/cm².

Benefits of arc protection

The AQ 100 series is focused on simplicity while maintaining both flexibility and function. The series is built to meet the growing demands in both LV and MV switchgear and controlgear applications, ranging from basic standalone solutions to more complex system solutions.

The AQ 100 series is designed and verified to meet the requirements of the latest protection relay standards. This makes it suitable for installations in any environment, from utilities and power plants to heavy industry applications (e.g. offshore, marine, mining) as well as commercial and institutional electrical systems. Its modular design makes the AQ 100 series an excellent candidate for both new and retrofit installations.

AQ-1000 and SIQuench arc quenching devices are used to extinguish arcing faults in LV and MV power systems where the breaker's operating time is not fast enough to reduce arc flash incident levels to a safe value.

The quenching device operates in less than 5 ms to minimize –or even eliminate– the damaging thermal and pressure effects of an arc fault. In most applications this will result in an energy release of 1 cal/cm². Both AQ-1000 and SIQuench can be re-activated and can perform several operations with a full short-circuit current. The arc protection systems with these quenching devices can also be fully tested on-site.

The arc quenching devices are installed as a part of the AQ 100 arc protection system. If an arc fault occurs, an AQ 100 series unit detects the fault, triggers the quenching device, and simultaneously trips the fault feeding circuit breaker(s). The quenching device creates a three-phase low impedance parallel path for fault current to flow thus extinguishing the arc fault instantaneously.

MAXIMUM SAFETY AND MINIMUM PROCESS DOWNTIME

- Total arc fault clearance time is less than 5 ms with a quenching device that can be re-activated
- Quarter cycle arcing time guarantees low incident energy levels
- Lower category personal protective equipment (PPE) needed

SAVE TIME AND MONEY

- Faster engineering with standard arc schemes
- Faster commissioning, one button configuration, clear LED signals, no software needed

- Full product range → optimal price/ functionality ratio for any application

THE MOST RELIABLE PROTECTION

- Design based on unbeatable experience in the field
- Track record of less than 0.1% return rate of products (more than 200 years)
- EMC isolation levels tested according to highest protection relay standards

SECURE OPERATION

- Designed and tested according to protection relay standards
- The quenching device that can be re-activated allows multiple operations in testing and fault conditions

- Optimized standard arc schemes for any type of switchgear
- Individual trip zones based on light and current or light and pressure
- Master trip to prevent back feed
- Built-in circuit breaker failure protection
- Built-in lock out

Medium-voltage products



AQ-110P CURRENT AND POINT SENSOR UNIT

A flush-mounted current and light sensing main unit. The unit has 4 current inputs (3 phase currents and 1 residual current). Up to 12 point sensors and 1 fiber sensor can be connected to the unit.



AQ-101D POINT SENSOR UNIT

A DIN rail-mounted light sensing unit. The unit can be installed as a sub-unit to an AQ-110P unit or as a standalone unit for light-only systems. Up to 12 point sensors and 1 fiber sensor can be connected to the unit.



AQ-110F CURRENT AND FIBER SENSOR UNIT

A flush-mounted current and light sensing main unit. The unit has 4 current inputs (3 phase currents and 1 residual current). Up to 3 fiber sensors can be connected to the unit.



AQ-101S POINT SENSOR UNIT WITH EXTENDED I/O

A flush-mounted light sensing unit for double busbar applications. The unit can be installed as a sub-unit to an AQ-110P unit or as a standalone unit for light-only systems. Up to 12 point sensors can be connected to the unit.



AQ-103 POINT SENSOR UNIT WITH MODBUS

A flush-mounted light sensing unit with optional Modbus communication. Up to 14 point sensors and 1 fiber sensor can be connected to the unit.



AQ-102 FIBER SENSOR UNIT

A flush-mounted light sensing unit. The unit can be installed as a sub-unit to an AQ-110F unit or as a standalone unit for light-only systems. Up to 3 fiber sensors can be connected to the unit.



AQ-101 POINT SENSOR UNIT

A flush-mounted light sensing unit. The unit can be installed as a sub-unit to an AQ-110P unit or as a standalone unit for light-only systems. Up to 12 point sensors and 1 fiber sensor can be connected to the unit.

Arcteq's arc flash protection relays require only minimal setting to be made.

Low-voltage products



AQ-110PLV CURRENT AND POINT SENSOR UNIT

A flush-mounted current and light sensing main unit. The unit has 3 phase current inputs. Up to 12 point sensors and 1 fiber sensor can be connected to the unit.



AQ-101LV POINT SENSOR UNIT

A flush-mounted light sensing unit. The unit can be installed as a sub-unit to an AQ-110PLV unit or as a standalone unit for light-only systems. Up to 12 point sensors and 1 fiber sensor can be connected to the unit.



AQ-110FLV CURRENT AND FIBER SENSOR UNIT

A flush-mounted current and light sensing main unit. The unit has 3 phase current inputs. Up to 3 fiber sensors can be connected to the unit.



AQ-101DLV POINT SENSOR UNIT

A DIN rail-mounted light sensing unit. The unit can be installed as a sub-unit to an AQ-110PLV unit or as a standalone unit for light-only systems. Up to 12 point sensors and 1 fiber sensor can be connected to the unit.



AQ-103LV POINT SENSOR UNIT WITH MODBUS

A flush-mounted light sensing unit with optional Modbus communication. Up to 14 point sensors and 1 fiber sensor can be connected to the unit.



AQ-102LV FIBER SENSOR UNIT

A flush-mounted light sensing unit. The unit can be installed as a sub-unit to an AQ-110FLV unit or as a standalone unit for light-only systems. Up to 3 fiber sensors can be connected to the unit.

Sensors (for MV and LV)



POINT SENSORS

AQ-01 detects an arc flash based on light activation.
AQ-02 detects an arc flash based on both light and pressure activation.



FIBER SENSORS

AQ-06 is a plastic fiber optic loop sensor that detects light.
AQ-07 and AQ-08 are glass fiber optic loop sensors; AQ-08 is meant for high temperatures.

Arc quenching devices



SIQUENCH 3AM4132

The arc quenching device can be re-activated and has a rated voltage of up to 17.5 kV.

SIQUENCH 3AM4143

The arc quenching device can be re-activated and has a rated voltage of up to 24 kV.



AQ-1000

The arc quenching device can be re-activated and has a rated voltage of up to 690 V.

AQ-1000 has been approved by the US Patent and Trade Office (no. 9,318,294).

- Limiting arcing time is crucial when an arc flash is active. Power systems that have high short-circuit currents (typically >20 kA) sustain substantial damage in just a few milliseconds, and the breaking time of a circuit breaker is too long to reduce the damage. Arc quenching devices absorb the energy of an arc flash long enough for the circuit breaker to open and quench the arc flash in less than 5 ms.
- AQ-1000 is designed to protect low-voltage power systems (up to 690 V AC) with a short-circuit current as high as 100 kA. As for systems with a nominal voltage of up to 24 kV AC and a rated short-circuit current of 50 kA, the SIQuench will ensure the ultimate protection against arc flashes.
- Both AQ-1000 and the SIQuenches are resettable devices. They are able to make numerous mechanical operations in testing and they can be easily re-engaged in a few minutes after protecting against an arc flash incident.

Protection for both personnel and equipment

The main purpose of arc flash protection is to protect both substation personnel and the equipment from the consequences of an arc fault. The best protection against arc faults is provided by an arc protection system with a quenching device: it detects an arc fault in 2 ms. When the delay in the breaker operation is included, extinguishing an arc fault normally takes less than 70 ms.

Comparatively, when a switchgear is covered by a protection system without a quencher, the typical clearing time is 50...80 ms. While this cuts the energy levels considerably, an arc fault poses still a notable risk. The lowest form of protection is a situation where a switchgear is only covered by a typical selective overcurrent protection. With operating times as high

as 500 ms, an arc fault has time to develop into a dangerous, high-energy incident which has a high risk of severe injuries to personnel.

Using the quenching device typically reduces the energy release to the lowest level according to IEEE 1584 (2018) and NFPA 70E (2018).

Arc quenching

Typical protective equipment (PPE)



Level of damage



Arc quenching	
Typical clearing time	< 4 ms
Energy level in a typical worst-case incident	>1.2...4.0 cal/cm ²
Level of typical personal protective equipment (PPE)	Category 1
Typical outage and repair time	60 min
Recommended	Fault current >20 kA and all important loads
Level of protection	ULTIMATE

Arc flash relay

Typical protective equipment (PPE)



Level of damage



Arc flash relay	
Typical clearing time	50...80 ms
Energy level in a typical worst-case incident	4.0...8.0 cal/cm ²
Level of typical personal protective equipment (PPE)	Category 2
Typical outage and repair time	Hours
Recommended	Fault current <10 kA and non-important loads
Level of protection	HIGH

Conventional relay

Typical protective equipment (PPE)



Level of damage

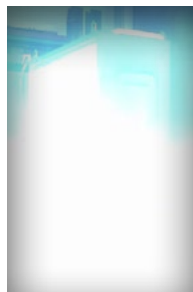

Conventional relay	
Typical clearing time	>500 ms
Energy level in a typical worst-case incident	>25.0 cal/cm ²
Level of typical personal protective equipment (PPE)	Category 4
Typical outage and repair time	Days or weeks
Recommended	Not recommended
Level of protection	LOW

Arc quenching device that can be re-activated for multiple trips

ARC FLASH INCIDENTS

Arc flash faults are the most devastating types of faults known in power distribution systems. Arc flash incidents in MV and LV air-insulated switchgear and controlgear are known to cause several injuries and fatalities every year, mainly by causing burns in the second and higher degrees. Arc flash faults also cause severe equipment damage, leading to time-consuming repairs and extended power outages.

Arc flash has been the subject of intense study in the past decade. Standards (such as IEEE 1584 and NFPA 70E) have quantified that the incident energy of an arc flash is directly proportional to the system voltage, the fault current as well as -most critically- how long the fault persists.

LIMITING THE ARCING TIME

Arc flash protection relays based on light and current detection have been applied to both MV and LV systems since the 1980s. Combining a fast-acting circuit breaker and a trip time that is as fast as 2 milliseconds typically provides a total clearing time of 5-8 cycles. This significantly reduces the amount of incident energy when compared to traditional overcurrent-based protection.

To overcome the limitations caused by a circuit breaker's opening time Arcteq has developed arc quenching devices for both MV and LV systems. Arcteq's arc quenching devices are an excellent addition to the well-proven AQ 100 arc flash protection relay system. The operation of an arc quenching device begins when it receives a triggering signal from a connected arc flash relay. Next, it creates a low-impedance path for the fault current to flow through by closing the three phases together. The system voltages drop, and the fault is extinguished within 4 milliseconds from its initiation.

ULTRAFAST AND MULTIPLE TRIPS

Arcteq arc quenching devices can be re-activated, which allows the system to be fully tested the system can be tested (and its operation time verified) both at the factory and on-site. A total arcing time of less than 5 ms typically reaches energy levels below 1..2 cal/cm² in LV systems. This ultrafast protection reduces system repair time from days and weeks to hours. The quenching devices are designed and built for heavy-duty use, and they are rated for fault currents of up to 100 kA to suite every application.

FOR LOW- AND MEDIUM-VOLTAGE SYSTEMS, FOR RETROFIT AND NEW INSTALLATIONS

Arcteq offers arc quenching solutions for both low- and medium-voltage applications. AQ-1000 is rated up to 690 V and can withstand 100 kA fault currents, whereas two SIQuench variants rate up to 24 kV and can withstand 50 kA fault currents.

A quenching device can be installed in either new or existing panels. Retrofitting the quenching device in an existing lineup is often an efficient way to prolong the switchgear's lifetime. Each busbar section requires one device, which is mounted in the most practical location within the switchgear. Typical locations include the voltage transformer compartments in medium-voltage applications and the incoming sections in low-voltage applications. When installing an arc quenching device, it is essential to ensure that the operation happens within the power system ratings.

NEW STANDARDS BY IEC AND UL

The first arc quenching device standards have been released for low-voltage applications. Arcteq's AQ-1000 arc quenching device has been successfully tested in accordance with the **UL 2748** standard ("Standard for Arcing Fault Quenching Equipment"). Additionally, AQ-1000 also complies with the newly released **IEC 60947-9-1:2018** arc quenching device standard.

Arcteq products are also an easy way to fully meet the new **IEC TS 63107** standard on the integration of internal arc fault mitigation systems in power switchgear and controlgear (PSC) assemblies. As a pioneer in arc flash systems, we provide products which can be integrated with any PSC assembly according to the latest standards and regulations.

AQ-1000 is the only arc quenching device capable of closing all three phases at the same time.



AQ-1000 arc quenching device

Dedicated and dependable protection with standard arc schemes

ARC FLASH PROTECTION - THE NEW NORMAL IN POWER GRID PROTECTION

During the last decade, the application of arc flash protection based on light sensing has become the new normal in power protection. Arc flash protection provides clear benefits, such as improved speed, selectivity, and cost-effectiveness. Arc flash protection can be found around the globe and it has been applied to all types of electrical power distribution systems ranging from electrical utility to traditional and renewable power generation, as well as industrial, marine, off-shore, institutional and commercial applications in both LV and MV switchgear and controlgear.

Protection relay manufacturers have incorporated arc flash protection features in multifunction protection relays. Because of this development, arc flash protection is often considered just as an additional protection function. This approach has clear shortcomings as it does not appreciate the critical and complex nature of arc flash protection. Selective and tailored tripping scenarios must be designed in such a way that protection operates flawlessly in every scenario and with any network topology, but at the same time systems must be designed with total selectivity which in turn limits the effected zone to a minimum in case an arc fault occurs. Therefore, arc flash protection should not be considered as a protection function but as a protection system in its own rights.

BENEFITS OF DEDICATED ARC FLASH PROTECTION RELAYS

Dedicated arc flash protection relays are designed for the sole purpose of protecting against arc faults. They operate in parallel with the numerous multifunction protection relay models that provide the classic overcurrent-based protection schemes. This approach provides redundant protection which then increases protection dependability.

Arcteq's dedicated arc flash relays require little to no customer settings. This is essential as studies confirm that up to 85% of the maloperations in arc protection is due on incorrect settings.

The development of Arcteq's arc flash relays takes a system-wide approach. The protection's operation time is 7 milliseconds for any number of circuit breakers under any operational scenario. There are no inherent delays due to communication bus operating times, which is of the outmost importance when calculating incident energy levels.

Standard Arc Schemes provide pre-engineered, fully tested, and fully documented arc flash protection systems for various common switchgear layouts.

ARCTEQ'S UNIQUE STANDARD ARC SCHEMES - IMPROVED SECURITY THROUGH SIMPLICITY

Standard Arc Schemes provide pre-engineered, fully tested, and fully documented arc flash protection systems for various common switchgear layouts. The added flexibility in arc detection and protection systems has led to situations where manufacturers have not been able to test all possible combinations of the protection scheme they have designed, which has caused complexions when the systems have been set up, wired, and commissioned. Using Standard Arc Schemes guarantees a fully tested protection scheme with standard wiring and settings.

The benefits of Standard Arc Schemes include faster engineering, easier commissioning phase, as well as dependable operation with minimal after-sales and life-cycle costs.

Typical standard arc scheme (LV)

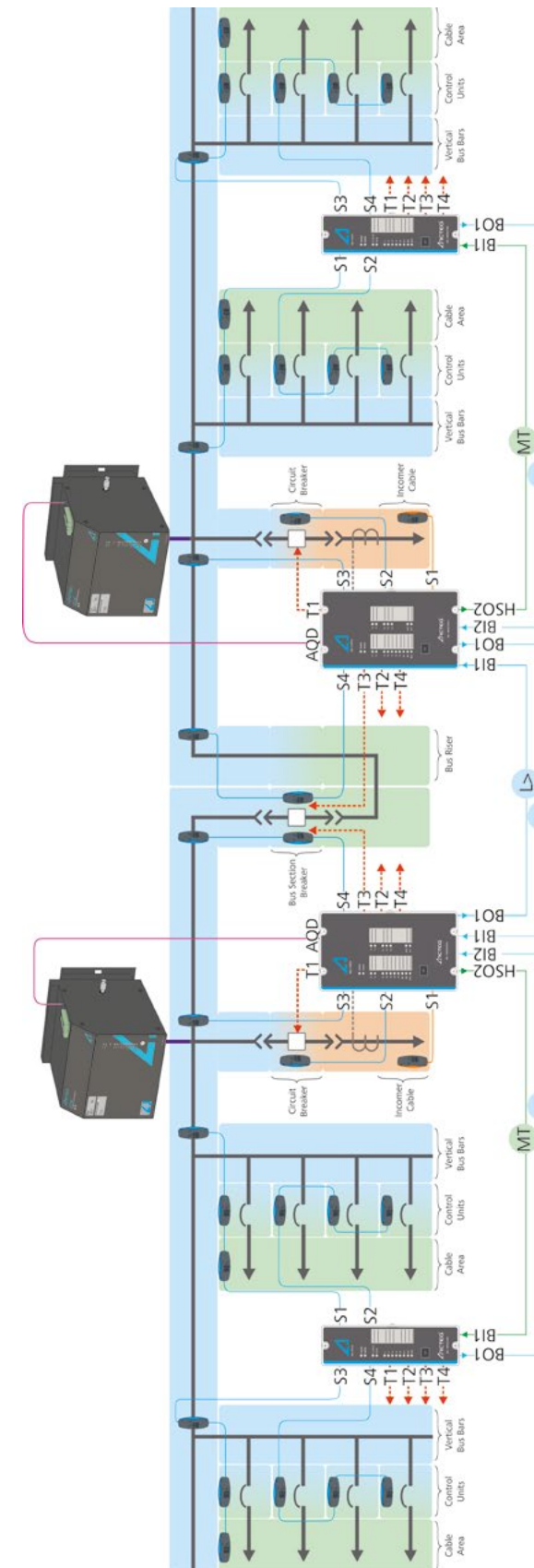

Standard arc scheme layout for low-voltage switchgear with two incoming circuit breakers and a tie breaker.

Typical standard arc scheme (MV)

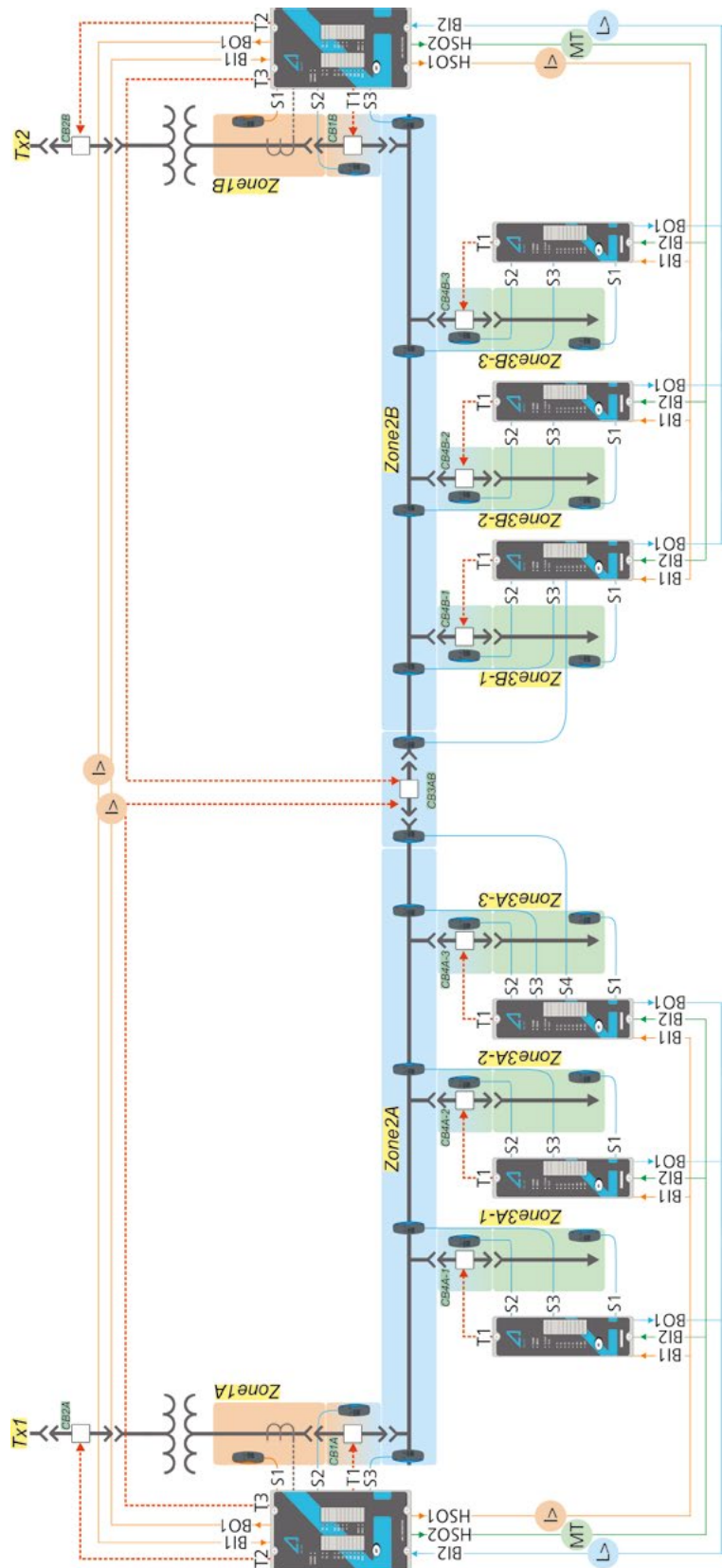

Standard arc scheme layout for medium-voltage switchgear with two incoming circuit breakers and a tie breaker.

Typical standard arc scheme for AQ-103

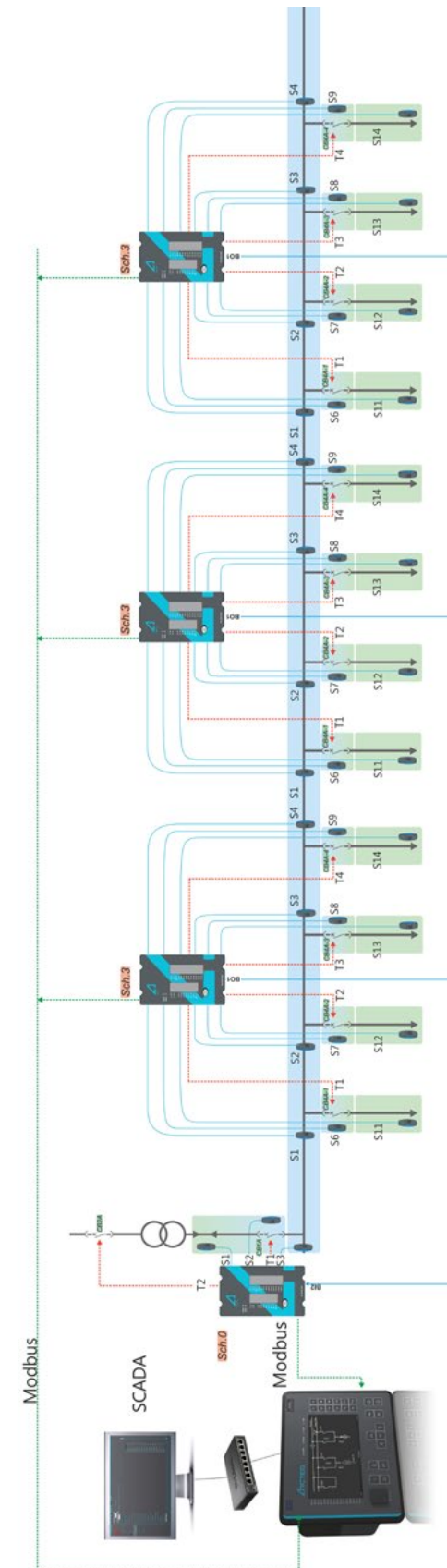

AQ-103 makes it possible to have fully feeder selective protection for up to four feeders, and it can be easily expanded to include a maximum of 64 feeders. When combined with the AQ-S254 alarm and indication device, AQ-103 equipped with Modbus communication also allows for a unique way of displaying events (such as fault locations in the mimic).

Adding the pressure criterion to arc flash protection

BACKGROUND

The first generations of arc flash protection relays only used light-sensitive arc sensors as the criterion for tripping the device. When arc light and current sensing were combined in the so-called dual sensing method, it further increased the reliability of the protection system. However, traditional dual sensing systems based on current and light can overtrip when installed in any equipment that also includes air magnetic circuit breakers. In some cases (especially in LV systems) the current criterion is nearly impossible to apply since there are no current transformers. Additionally, the incoming cable compartments in an MV switchgear cannot be protected with light and current when the overcurrent is measured from the protected switchgear.

APPLYING A LIGHT AND PRESSURE SENSOR TO A SYSTEM WITH AN AIR CIRCUIT BREAKER

It is a truth universally acknowledged that low-voltage air circuit breakers create strong light emissions when a breaking sequence occurs under load. Furthermore, when a low-voltage or magnetic air circuit breaker operates on a downstream fault, its arc chutes create an arcing that may activate any arc light sensors installed nearby. Since a downstream fault condition typically leads to exceeding the set overcurrent trip threshold, both light and current conditions may be fulfilled simultaneously. This may result in a nuisance trip of the incoming feeder's circuit breaker in the dual sensing arc flash protection system based on light and overcurrent.

Adding an arc flash pressure sensor into schemes which include air circuit breakers provides an additional trip criterion that will not be fulfilled by normal circuit breaker operations, making it easy to prevent potential nuisance trips. Using Arcteq's AQ-02 point sensor, which combines arc light and pressure sensing within a single enclosure, provides a convenient solution to dual sensing that is also easy to install. If needed, you can also apply overcurrent sensing to the system and make a triple sensing system with current, light and pressure trip criteria.

SENSOR AND SCHEME TESTING

Testing the full arc flash protection scheme is the most important part of every project execution. A typical testing situation includes the activation of each sensor and then monitoring the correct feedback from all relays involved in the scheme. All primary equipment (such as current transformers, circuit breakers and arc quenching devices) must also be tested to secure correct operation throughout the chain.

Arcteq's new arc light and pressure sensor testing device AST-02 is designed to facilitate system testing either in the factory or on-site. The tester provides three different light threshold levels to secure the correct operation of any light sensor regardless of the sensor's own

sensitivity level. The pressure element can be triggered at the same time as light to test the AQ-02 light and pressure point sensor. Additionally, the tester can be connected to any third-party relay tester to simulate the overcurrent condition and to record the total operation time of the arc flash protection system. A circuit breaker failure scheme can be also simulated with the AST-02 tester.

CONCLUSIONS

Applying a light and pressure point sensor to the system addresses the shortcomings of light and current criteria. When a pressure sensor is applied to an arc flash protection system, it provides increased system reliability without compromising the desired dual sensing criteria. Adding the pressure criterion is especially encouraged for systems that include magnetic air circuit breakers. Also, pressure sensing should be considered when there are no current transformers within the protected zone. A pressure and light sensor such as AQ-02 can be applied as a standalone solution with light and pressure being the only two tripping criteria, or it can be used in combination with overcurrent tripping to create triple sensing system.

A light and pressure point sensor can be used to eliminate nuisance trips with air circuit breakers.



AST-02 tester can be used for light and pressure testing



AQ-02 light and pressure sensor

Gateway in arc protection schemes

The AQ-S254A alarm annunciator can be included in an AQ 100 series arc protection system, where it functions as the system's gateway. With the graphical mimic editor, you can add a local HMI display for the arc protection system. Another HMI display is dedicated for self-supervision, for light and current activation, as well as for trip alarms with events logs from every AQ 100 series device. With AQ-S254A as the system gateway, you can extend the communication on the substation level to RTU or directly to SCADA. AQ-S254A includes the IEC 101/104 protocols for the SCADA connection.

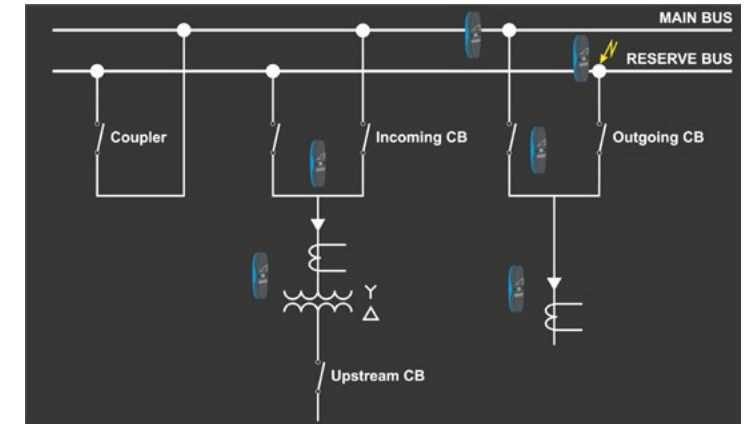

A single-line diagram indicating a faulty section in an AQ 100 arc protection system."

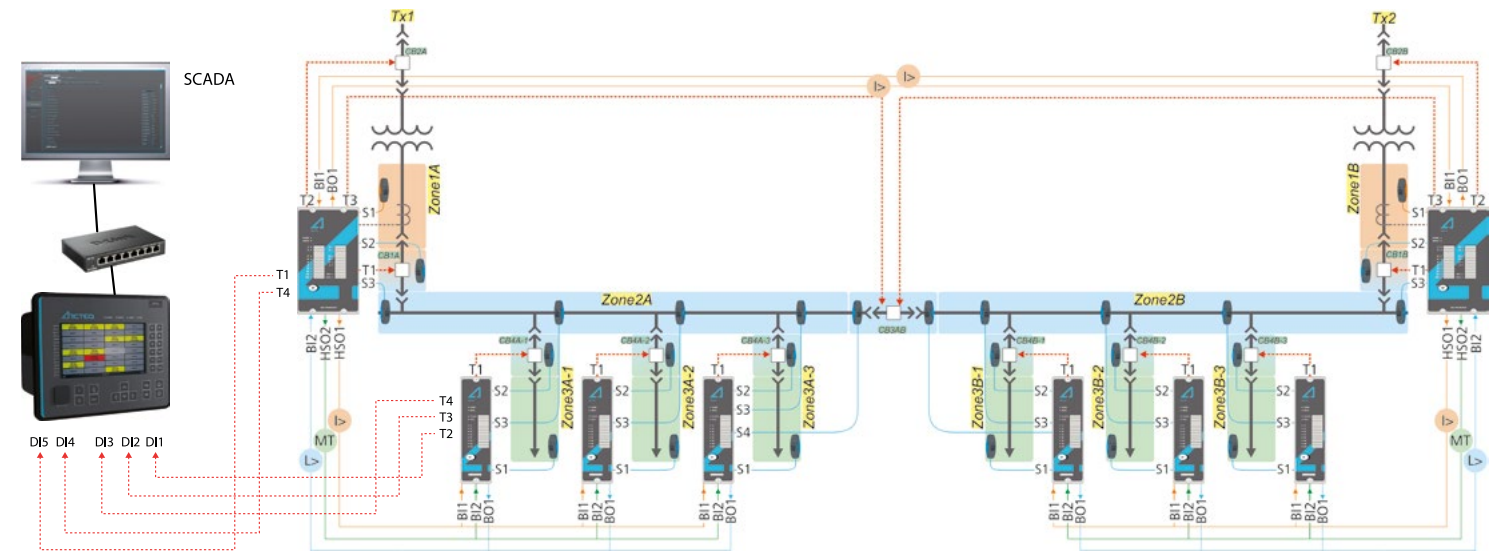



ORDER CODE

AQ-110P - X X X A

Unit type	
P Point sensor unit	
Auxiliary power supply	
A 92...265 V AC/DC	
B 18...72 V DC	
T3 trip relay setting	
A Normally open (NO)	
B Normally closed (NC), or Electronic lock-out	
Additional sensor channel	
A None	
B Fiber optic sensor channel / AQD control	
Binary input threshold voltage	
A 24 V DC	

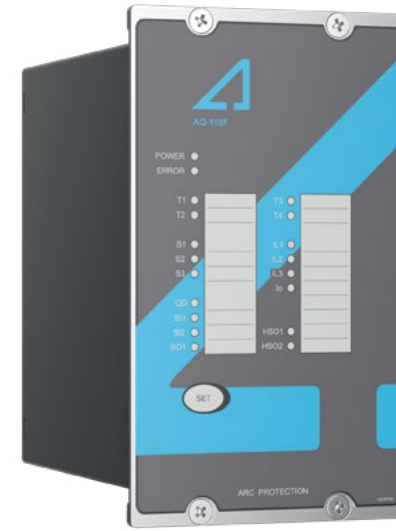

ORDER CODE

AQ-110F - X X X A

Unit type	
F Fiber sensor unit	
Auxiliary power supply	
A 92...265 V AC/DC	
B 18...72 V DC	
T3 trip relay setting	
A Normally open (NO)	
B Normally closed (NC), or Electronic lock-out	
Additional sensor channel	
A None	
B AQD control	
C Low fiber input sensitivity (S1-S3)	
Binary input threshold voltage	
A 24 V DC	

AQ-110P Current and point sensor unit



READ MORE

AQ-110P is a sophisticated microprocessor-based arc flash protection unit with combined current and arc sensing. When AQ-110P detects overcurrent in the incoming feeder and a light signal from a sub-unit or a direct light sensor, it minimizes the damage caused by an arcing fault (arc flash) by tripping the circuit breaker that sources the fault current. The complete system self-supervision function of AQ-110P provides the highest level of dependability by continuously monitoring all internal system functions as well as external connections.

HIGHLIGHTS:

- Has current and light detection.
- Connects to AQ-1000 and SIQuench arc quenching devices for rapid arc extinguishing.
- Connects to a maximum of 12 point sensors.
- Has full self-supervision of all system components and interconnections.

AQ-110F Current and fiber sensor unit



READ MORE

AQ-110F is a sophisticated microprocessor-based arc flash protection unit with combined current and arc sensing. When AQ-110F detects overcurrent in the incoming feeder and a light signal from a sub-unit or a direct light sensor, it minimizes the damage caused by an arcing fault (arc flash) by tripping the circuit breaker that sources the fault current. The complete system self-supervision function of AQ-110F provides the highest level of dependability by continuously monitoring all internal system functions as well as external connections.

HIGHLIGHTS:

- Connects 3 fiber sensors.
- Has a superior isolation level against external disturbances - tested at the highest EMC classes.
- Has a trip time as fast as 2 ms.
- Trips up to 4 breakers.

PROTECTION

- Overcurrent (50Arc)
- Ground fault (50NArc)
- Light (L->)
- Light and pressure (L> / P->)
- Circuit breaker failure protection (50BF/52BF)
- Trip time when using mechanical trip relays: 7 ms*
- Reset time (arc light stage): 2 ms
- *) total trip time when using arc light (L->) and phase/residual overcurrent (I->) from an AQ-110x unit

I/O

- Applicable sensors:**
- AQ-01 light sensor**
 - AQ-02 light and pressure sensor**
 - AQ-06 plastic fiber sensor (3...40 m) (optional)
 - AQ-07 glass fiber sensor (3...50 m) (optional)
 - AQ-08 glass fiber sensor (3...15 m) (optional)
- ** Activation threshold options:
8,000/25,000/50,000 lx

- Trip relays (T1, T2, T3, T4)**
- Number: 3 NO + 1 NC or 4 NO
 - Rated voltage: 250 V AC/DC
 - Continuous carry: 5 A
 - Make-and-carry for 3 s: 16 A
 - Make-and-carry for 0.5 s: 30 A
 - Breaking capacity DC (when L/R = 40 ms): 40 W; 0.36 A at 110 V DC
 - Contact material: AgNi 90/10

Binary output B01

- Number of outputs: 1
- Rated voltage: +24 V DC
- Maximum rated current: 20 mA

Binary inputs (B11, B12)

- Number of inputs: 2
- Threshold voltage: 24 V DC
- Rated voltage: 250 V
- Rated current: 3 mA

Power supply

- Auxiliary power supply: 92...265 V AC/DC
- Auxiliary power supply: 18...72 V DC (optional)
- Maximum interruption: 100 ms
- Maximum power consumption: 5 W
- Standby current: 90 mA

HMI

- 20 indication LEDs
- Multifunction push button (SET)
- Autoconfiguration
- Indication reset
- System check

SELF SUPERVISION

- Sensors and wiring
- Binary I/O
- Trip coil
- Power supply
- Internal voltages
- Settings
- CT connections

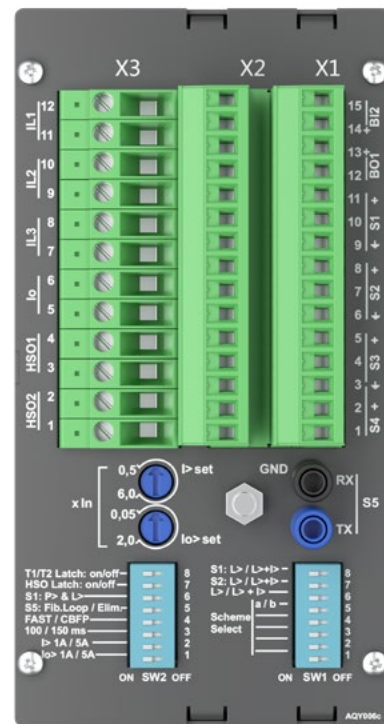

AQ-110P rear view

PROTECTION

- Overcurrent (50Arc)
- Ground fault (50NArc)
- Light (L->)
- Circuit breaker failure protection (50BF/52BF)
- Trip time when using mechanical trip relays: 7 ms*
- Reset time (arc light stage): 2 ms
- *) total trip time when using arc light (L->) and phase/residual overcurrent (I->) from an AQ-110x unit

I/O

- Applicable sensors:**
- AQ-06 plastic fiber sensor (3...40 m) (optional)
 - AQ-07 glass fiber sensor (3...50 m) (optional)
 - AQ-08 glass fiber sensor (3...15 m) (optional)

Trip relays (T1, T2, T3, T4)

- Number: 3 NO + 1 NC or 4 NO
- Rated voltage: 250 V AC/DC
- Continuous carry: 5 A
- Make-and-carry for 3 s: 16 A
- Make-and-carry for 0.5 s: 30 A
- Breaking capacity DC (when L/R = 40 ms): 40 W; 0.36 A at 110 V DC
- Contact material: AgNi 90/10

Binary output (B01)

- Number of outputs: 1
- Rated voltage: +24 V DC
- Maximum rated current: 20 mA

Binary inputs (B11, B12)

- Number of inputs: 2
- Threshold voltage: 24 V DC
- Rated voltage: 250 V
- Rated current: 3 mA

Power supply

- Auxiliary power supply: 92...265 V AC/DC
- Auxiliary power supply: 18...72 V DC (optional)
- Maximum interruption: 100 ms
- Maximum power consumption: 5 W
- Standby current: 90 mA

HMI

- 19 indication LEDs
- Multifunction push button (SET)
- Autoconfiguration
- Indication reset
- System check

SELF SUPERVISION

- Sensors and wiring
- Binary I/O
- Trip coil
- Power supply
- Internal voltages
- Settings
- CT connections

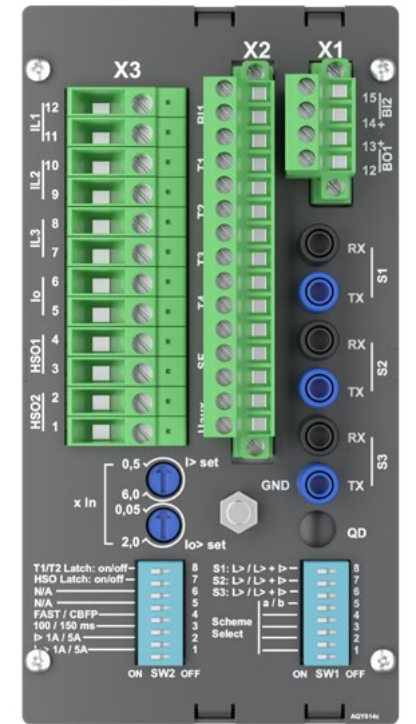

AQ-110F rear view



AQ-103 Point sensor unit with Modbus



READ MORE

AQ-103 is a sophisticated microprocessor-based arc flash protection unit with arc light detection. It acts as a sub-unit to an AQ-110P unit in an AQ 100 arc protection system. It can also function as a standalone unit in light-only systems. AQ-103 is designed to minimize the damage caused by an arcing fault (arc flash) by tripping the circuit breaker that sources the fault current. The complete system self-supervision function of AQ-103 provides the highest level of dependability by continuously monitoring all internal system functions as well as external connections. AQ-103 provides communication through Modbus protocol.

PROTECTION

- Light (L>)
- Light and pressure (L> / P>)
- Circuit breaker failure protection (50BF/52BF)
- Trip time when using mechanical trip relays: 7 ms*
- Reset time (arc light stage): 2 ms
- *) total trip time when using arc light (L>) and phase/residual overcurrent (I>) from an AQ-110x unit

I/O

- Applicable sensors:
 - AQ-01 light sensor**
 - AQ-02 light and pressure sensor**
 - AQ-06 plastic fiber sensor (3...40 m) (optional)
 - AQ-07 glass fiber sensor (3...50 m) (optional)
 - AQ-08 glass fiber sensor (3...15 m) (optional)
- ***) Activation threshold options: 8,000/25,000/50,000 lx
- Trip relays (T1, T2, T3, T4)
- Number: 3 NO + 1 NC or 4 NO
- Rated voltage: 250 V AC/DC
- Continuous carry: 5 A
- Make-and-carry for 3 s: 16 A
- Make-and-carry for 0.5 s: 30 A
- Breaking capacity DC (when L/R = 40 ms): 40 W; 0.36 A at 110 V DC
- Contact material: AgNi 90/10
- Binary output (BO1)
- Number of outputs: 1

- Rated voltage: +24 V DC
- Maximum rated current: 20 mA
- Binary inputs (B11, B12)
- Number of inputs: 2
- Threshold voltage: 24 V DC
- Rated voltage: 250 V
- Rated current: 3 mA
- Power supply
- Auxiliary power supply: 92...265 V AC/DC
- Auxiliary power supply: 18...72 V DC (optional)
- Maximum interruption: 100 ms
- Maximum power consumption: 5 W
- Standby current: 90 mA

HMI

- 25 indication LEDs
- Multifunction push button (SET)
- Autoconfiguration
- Indication reset
- System check

SELF SUPERVISION

- Sensors and wiring
- Binary I/O
- Trip coil
- Power supply
- Internal voltages
- Settings

ORDER CODE

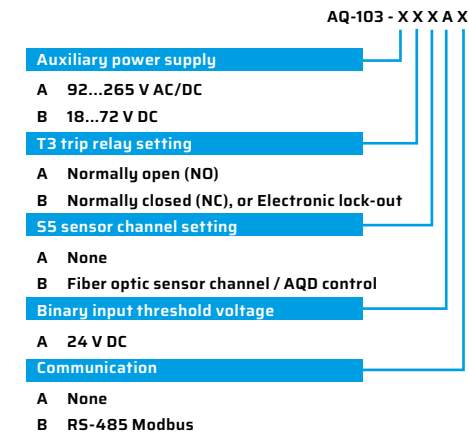

HIGHLIGHTS:

- Connects to a maximum of 14 point sensors and 1 fiber sensor.
- Has a variant with Modbus communication.

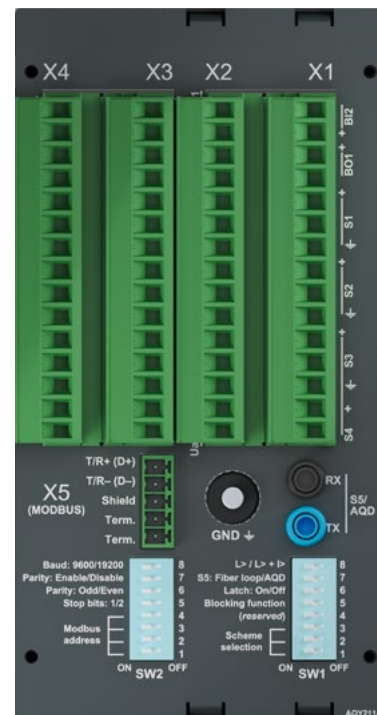

AQ-103 rear view, Modbus variant



AQ-101 Point sensor unit



READ MORE

AQ-101 is a sophisticated microprocessor-based arc flash protection unit for arc light detection. It is designed to minimize the damage caused by an arcing fault (arc flash) by tripping the circuit breaker that sources the fault current. AQ-101 acts as a sub-unit to an AQ-110P unit in an AQ 100 arc protection system. It can also function as a standalone unit in light-only systems.

The complete system self-supervision function of AQ-101 provides the highest level of dependability by continuously monitoring all internal system functions as well as external connections.

PROTECTION

- Light (L>)
- Light and pressure (L> / P>)
- Circuit breaker failure protection (50BF/52BF)
- Trip time when using mechanical trip relays: 7 ms*
- Reset time (arc light stage): 2 ms
- *) total trip time when using arc light (L>) and phase/residual overcurrent (I>) from an AQ-110x unit

I/O

- Applicable sensors:
 - AQ-01 light sensor**
 - AQ-02 light and pressure sensor**
 - AQ-06 plastic fiber sensor (3...40 m) (optional)
 - AQ-07 glass fiber sensor (3...50 m) (optional)
 - AQ-08 glass fiber sensor (3...15 m) (optional)
- ***) Activation threshold options: 8,000/25,000/50,000 lx
- Trip relays (T1, T2, T3, T4)
- Number: 3 NO + 1 NC or 4 NO
- Rated voltage: 250 V AC/DC
- Continuous carry: 5 A
- Make-and-carry for 3 s: 16 A
- Make-and-carry for 0.5 s: 30 A
- Breaking capacity DC (when L/R = 40 ms): 40 W; 0.36 A at 110 V DC
- Contact material: AgNi 90/10

Binary output (BO1)

- Number of outputs: 1
- Rated voltage: +24 V DC
- Maximum rated current: 20 mA

Binary inputs (B11, B12)

- Number of inputs: 2
- Threshold voltage: 24 or 110 or 220 V DC
- Rated voltage: 250 V
- Rated current: 3 mA

Power supply

- Auxiliary power supply: 92...265 V AC/DC
- Auxiliary power supply: 18...72 V DC (optional)
- Maximum interruption: 100 ms
- Maximum power consumption: 5 W
- Standby current: 90 mA

HMI

- 12 indication LEDs
- Multifunction push button (SET)
- Autoconfiguration
- Indication reset
- System check

SELF SUPERVISION

- Sensors and wiring
- Binary I/O
- Trip coil
- Power supply
- Internal voltages
- Settings

ORDER CODE

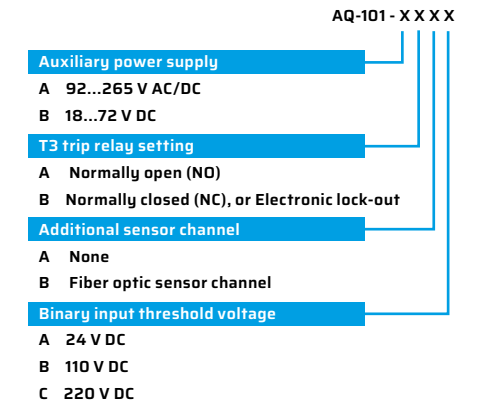

HIGHLIGHTS:

- A practically unlimited number of units can be interconnected in one system.
- Standard Arc Schemes allow for fast engineering and simple setting.
- Connects to a maximum of 12 point sensors and 1 fiber sensor (optional).



AQ-101 rear view



ORDER CODE

AQ-101D - X X X X	
Auxiliary power supply	
A	92...265 V AC/DC
B	18...72 V DC
T3 trip relay setting	
A	Normally open (NO)
B	Normally closed (NC), or Electronic lock-out
Additional sensor channel	
A	None
B	Fiber optic sensor channel
Binary input threshold voltage	
A	24 V DC
B	110 V DC
C	220 V DC

AQ-101D Point sensor unit (DIN rail)



READ MORE

AQ-101D is a sophisticated microprocessor-based arc flash protection unit for arc light detection. It is designed to minimize the damage caused by an arcing fault (arc flash) by tripping the circuit breaker that sources the fault current. AQ-101D acts as a sub-unit to an AQ-110P unit in an AQ 100 arc protection system. It can also function as a standalone unit in light-only systems.

The complete system self-supervision function of AQ-101D provides the highest level of dependability by continuously monitoring all internal system functions as well as external connections.

HIGHLIGHTS:

- Allows for easy DIN rail installation.
- Has 12 indication LEDs for fault analysis.

PROTECTION

- Light (L>)
- Light and pressure (L> / P>)
- Circuit breaker failure protection (50BF/52BF)
- Trip time when using mechanical trip relays: 7 ms*
- Reset time (arc light stage): 2 ms
- *) total trip time when using arc light (L>) and phase/residual overcurrent (I>) from an AQ-110x unit

I/O

- Applicable sensors:**
- AQ-01 light sensor**
 - AQ-02 light and pressure sensor**
 - AQ-06 plastic fiber sensor (3...40 m) (optional)
 - AQ-07 glass fiber sensor (3...50 m) (optional)
 - AQ-08 glass fiber sensor (3...15 m) (optional)
 - **) Activation threshold options: 8,000/25,000/50,000 lx
 - Trip relays (T1, T2, T3, T4)
 - Number: 3 NO + 1 NC or 4 NO
 - Rated voltage: 250 V AC/DC
 - Continuous carry: 5 A
 - Make-and-carry for 3 s: 16 A
 - Make-and-carry for 0.5 s: 30 A
 - Breaking capacity DC (when L/R = 40 ms): 40 W; 0.36 A at 110 V DC
 - Contact material: AgNi 90/10

Binary output (B01)

- Number of outputs: 1
- Rated voltage: +24 V DC
- Maximum rated current: 20 mA

Binary inputs (BI1, BI2)

- Number of inputs: 2
- Threshold voltage: 24 or 110 or 220 V DC
- Rated voltage: 250 V
- Rated current: 3 mA

Power supply

- Auxiliary power supply: 92...265 V AC/DC
- Auxiliary power supply: 18...72 V DC (optional)
- Maximum interruption: 100 ms
- Maximum power consumption: 5 W
- Standby current: 90 mA

HMI

- 12 indication LEDs
- Multifunction push button (SET)
- Autoconfiguration
- Indication reset
- System check

SELF SUPERVISION

- Sensors and wiring
- Binary I/O
- Trip coil
- Power supply
- Internal voltages
- Settings

The complete system self-supervision function of AQ-101D provides the highest level of dependability by continuously monitoring all internal system functions as well as external connections. protection systems for various common switchgear layouts.



ORDER CODE

AQ-101S - X A A X	
Auxiliary power supply	
A	92...265 V AC/DC
B	18...72 V DC
T3 trip relay setting	
A	Normally open (NO)
Additional sensor channel	
A	None
Binary input threshold voltage	
A	24 V DC
B	110 V DC
C	220 V DC

AQ-101S Point sensor unit with extended I/O



READ MORE

AQ-101S is a sophisticated microprocessor-based arc flash protection unit for arc light detection. It is designed to minimize the damage caused by an arcing fault (arc flash) by tripping the circuit breaker that sources the fault current. AQ-101S acts as a sub-unit to an AQ-110P unit in an AQ 100 arc protection system. It can also function as a standalone unit in light-only systems.

AQ-101S has an extended I/O ability to receive status information from a bay disconnect switch, which the special arc scheme for double busbar installation requires. The complete system self-supervision function of AQ-101S provides the highest level of dependability by continuously monitoring all internal system functions as well as external connections.

HIGHLIGHTS:

- Has an extended I/O for double busbar installation.
- Supports standard hardwiring practices for communication between units.
- Has a superior isolation level against external disturbances - tested at the highest EMC classes.

PROTECTION

- Light (L>)
- Light and pressure (L> / P>)
- Circuit breaker failure protection (50BF/52BF)
- Trip time when using mechanical trip relays: 7 ms*
- Reset time (arc light stage): 2 ms
- *) total trip time when using arc light (L>) and phase/residual overcurrent (I>) from an AQ-110x unit.

I/O

- Applicable sensors:**
- AQ-01 light sensor**
 - AQ-02 light and pressure sensor**
 - **) Activation threshold options: 8,000/25,000/50,000 lx

Trip relays (T1, T2, T3)

- Number: 2 NO + 1 NC or 3 NO
- Rated voltage: 250 V AC/DC
- Continuous carry: 5 A
- Make-and-carry for 3 s: 16 A
- Make-and-carry for 0.5 s: 30 A
- Breaking capacity DC (when L/R = 40 ms): 40 W; 0.36 A at 110 V DC
- Contact material: AgNi 90/10

Binary outputs (B01, B02, B03)

- Number of outputs: 3
- Rated voltage: +24 V DC
- Maximum rated current: 20 mA

Binary inputs

- (BI1, BI2, BI3, BI4, BI5, BI6)
- Number of inputs: 6
- Threshold voltage: 24 or 110 or 220 V DC
- Rated voltage: 250 V
- Rated current: 3 mA

Power supply

- Auxiliary power supply: 92...265 V AC/DC
- Auxiliary power supply: 18...72 V DC (optional)
- Maximum interruption: 100 ms
- Maximum power consumption: 5 W
- Standby current: 90 mA

HMI

- 17 indication LEDs
- Multifunction push button (SET)
- Autoconfiguration
- Indication reset
- System check

SELF SUPERVISION

- Sensors and wiring
- Binary I/O
- Trip coil
- Power supply
- Internal voltages
- Settings

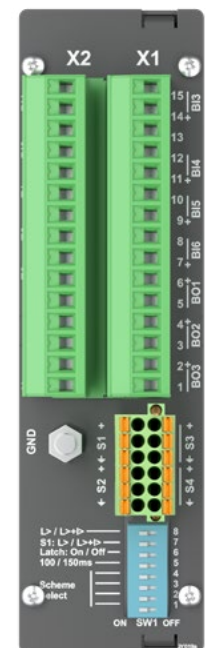

AQ-101S rear view



AQ-102 Fiber sensor unit



READ MORE

AQ-102 is a sophisticated microprocessor-based arc flash protection unit for arc light detection. It has connectors for up to three fiber sensors. AQ-102 is designed to minimize the damage caused by an arcing fault (arc flash) by tripping the circuit breaker that sources the fault current. AQ-102 acts as a sub-unit to an AQ-110x unit in an AQ 100 arc protection system. It can also function as a standalone unit in light-only systems. The complete system self-supervision function of AQ-102 provides the highest level of dependability by continuously monitoring all internal system functions as well as external connections.

PROTECTION

- ▶ Light (L->)
- ▶ Circuit breaker failure protection (50BF/52BF)
- ▶ Trip time when using mechanical trip relays: 7 ms*
- ▶ Reset time (arc light stage): 2 ms
- ▶ *) total trip time when using arc light (L->) and phase/residual overcurrent (I->) from an AQ-110x unit

I/O

Applicable sensors:

- ▶ AQ-06 plastic fiber sensor (3...40 m) (optional)
- ▶ AQ-07 glass fiber sensor (3...50 m) (optional)
- ▶ AQ-08 glass fiber sensor (3...15 m) (optional)

Trip relays (T1, T2, T3, T4)

- ▶ Number: 3 NO + 1 NC or 4 NO
- ▶ Rated voltage: 250 V AC/DC
- ▶ Continuous carry: 5 A
- ▶ Make-and-carry for 3 s: 16 A
- ▶ Make-and-carry for 0.5 s: 30 A
- ▶ Breaking capacity DC (when L/R = 40 ms): 40 W; 0.36 A at 110 V DC
- ▶ Contact material: AgNi 90/10

Binary output (B01)

- ▶ Number of outputs: 1
- ▶ Rated voltage: +24 V DC
- ▶ Maximum rated current: 20 mA

Binary inputs (B11, B12)

- ▶ Number of inputs: 2
- ▶ Threshold voltage: 24 or 110 or 220 V DC
- ▶ Rated voltage: 250 V
- ▶ Rated current: 3 mA

Power supply

- ▶ Auxiliary power supply: 92...265 V AC/DC
- ▶ Auxiliary power supply: 18...72 V DC (optional)
- ▶ Maximum interruption: 100 ms
- ▶ Maximum power consumption: 5 W
- ▶ Standby current: 90 mA

HMI

- ▶ 11 indication LEDs
- ▶ Multifunction push button (SET)
- ▶ Autoconfiguration
- ▶ Indication reset
- ▶ System check

SELF SUPERVISION

- ▶ Sensors and wiring
- ▶ Binary I/O
- ▶ Trip coil
- ▶ Power supply
- ▶ Internal voltages
- ▶ Settings

ORDER CODE

Parameter	Options
Auxiliary power supply	A 92...265 V AC/DC B 18...72 V DC
T3 trip relay setting	A Normally open (NO) B Normally closed (NC), or Electronic lock-out
Additional sensor channel	A None B AQD control C Low fiber input sensitivity (S1-S3)
Binary input threshold voltage	A 24 V DC B 110 V DC C 220 V DC

AQ-102 - X X X X

HIGHLIGHTS:

- Connects to a maximum of 3 fiber sensors.
- Has full self-supervision of all system components and interconnections.
- Adapts easily to any switchgear and trip scheme.



AQ-102 rear view

ORDER CODE

SIQuench 3AM4132
3AM4132 - 1DA12 - 0AB2 - Z

Standard features

- Arc quenching device (17.5 kV)
- 31.5 kA (3 s)
- BIL: 95 kV
- Can be re-activated
- Mechanical life: 30 operations
- Electrical life: 5 operations
- Auxiliary supply: 110...250 V AC/DC
- Phase conductor displacement: 170 mm (total width 580 mm)
- Included: controller (trigger device) connection cables

ORDER CODE

SIQuench 3AM4143
3AM4143 - 3DA12 - 0AB2 - Z

Standard features

- Arc quenching device (24 kV)
- 50 kA (3 s)
- BIL: 125 kV
- Can be re-activated
- Mechanical life: 30 operations
- Electrical life: 5 operations
- Auxiliary supply: 110...250 V AC/DC
- Phase conductor displacement: 210 mm (total width 740 mm)
- Included: controller (trigger device) connection cables

Accessories	Order code
Connection fiber (3 meters)	AX001 - 3
Connection fiber (3 meters)	AX001 - 5
Connection fiber (10 meters)	AX001 - 10

SIQuench 3AM4132 and 3AM4143 Arc quenching devices



READ MORE

SIQuench is an arc quenching device which extinguishes arcing faults within 5 ms of arc initiation. The device is installed as a part of an AQ 100 arc protection system. When an AQ 100 series unit detects an arc fault, it triggers the SIQuench arc quenching system and trips the circuit breaker(s) feeding the fault, both at the same time. Then SIQuench creates a low-impedance parallel path for the fault current to flow through. The total arcing time is less than 5 milliseconds, which mitigates the risk of personal injuries and of damages to equipment.

HIGHLIGHTS:

- Mitigates the risk of injury during operations and maintenance.
- Minimizes damage to equipment.
- Is applicable to both new and retrofit installations.

Arc quenching device that can be re-activated for a total arcing time of less than 5 ms.

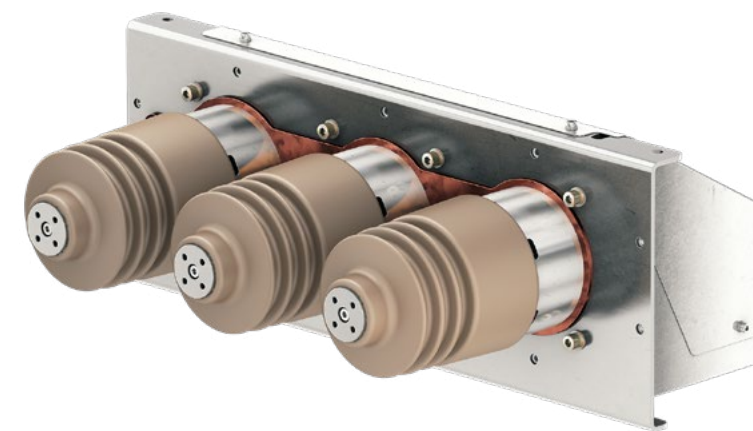

SIQuench arc quenching device

Siemens and SIQuench are registered trademarks of Siemens Aktiengesellschaft.



ORDER CODE AQ-110 P LV - X X X A

- Unit type**
P Point sensor unit
- Auxiliary power supply**
A 92...265 V AC/DC
B 18...72 V DC
- T3 trip relay setting**
A Normally open (NO)
B Normally closed (NC), or Electronic lock-out
- Additional sensor channel**
A None
B Fiber optic sensor channel / AQD control
- Binary input threshold voltage**
A 24 V DC



ORDER CODE AQ-110 FLV - X X X A

- Unit type**
F Fiber sensor unit
- Auxiliary power supply**
A 92...265 V AC/DC
B 18...72 V DC
- T3 trip relay setting**
A Normally open (NO)
B Normally closed (NC), or Electronic lock-out
- Additional sensor channel**
A None
B AQD control
C Low fiber input sensitivity (S1-S3)
- Binary input threshold voltage**
A 24 V DC

AQ-110PLV Current and point sensor unit



AQ-110PLV is a sophisticated microprocessor-based arc flash protection unit with combined current and arc sensing. When AQ-110PLV detects overcurrent in the incoming feeder and a light signal from a sub-unit or a direct light sensor, it minimizes the damage caused by an arcing fault (arc flash) by tripping the circuit breaker that sources the fault current. The complete system self-supervision function of AQ-110PLV provides the highest level of dependability by continuously monitoring all internal system functions as well as external connections.

HIGHLIGHTS:

- Has current and light detection.
- Connects to AQ-1000 and SIQuench arc quenching devices for rapid arc extinguishing.
- Connects to a maximum of 12 point sensors.
- Has full self-supervision of all system components and interconnections.

PROTECTION

- Overcurrent (50Arc)
- Light (L>)
- Light and pressure (L> / P>)
- Circuit breaker failure protection (50BF/52BF)
- Trip time when using mechanical trip relays: 7 ms*
- Reset time (arc light stage): 2 ms
- *) total trip time when using arc light (L>) and phase/residual overcurrent (I>) from an AQ-110xLV unit

I/O

Applicable sensors

- AQ-01 light sensor**
- AQ-02 light and pressure sensor**
- AQ-06 plastic fiber sensor (3...40 m) (optional)
- AQ-07 glass fiber sensor (3...50 m) (optional)
- AQ-08 glass fiber sensor (3...15 m) (optional)
- **) Activation threshold options: 8,000/25,000/50,000 lx

Trip relays (T1, T2, T3, T4)

- Number: 3 NO + 1 NC or 4 NO
- Rated voltage: 250 V AC/DC
- Continuous carry: 5 A
- Make-and-carry for 3 s: 16 A
- Make-and-carry for 0.5 s: 30 A
- Breaking capacity DC (when L/R = 40 ms): 40 W; 0.36 A at 110 V DC
- Contact material: AgNi 90/10

Binary output (BO1)

- Number of outputs: 1
- Rated voltage: +24 V DC
- Maximum rated current: 20 mA

Binary inputs (BI1, BI2)

- Number of inputs: 2
- Threshold voltage: 24 V DC
- Rated voltage: 250 V
- Rated current: 3 mA

Power supply

- Auxiliary power supply: 92...265 V AC/DC
- Auxiliary power supply: 18...72 V DC (optional)
- Maximum interruption: 100 ms
- Maximum power consumption: 5 W
- Standby current: 90 mA

HMI

- 19 indication LEDs
- Multifunction push button (SET)
- Autoconfiguration
- Indication reset
- System check

SELF SUPERVISION

- Sensors and wiring
- Binary I/O
- Trip coil
- Power supply
- Internal voltages
- Settings
- CT connections

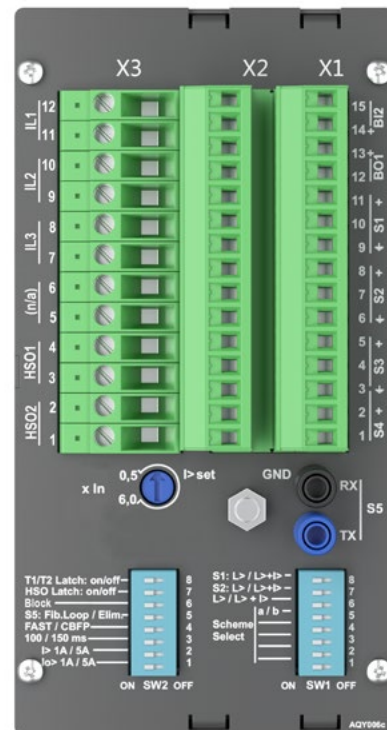

AQ-110PLV rear view

AQ-110FLV Current and fiber sensor unit



AQ-110FLV is a sophisticated microprocessor-based arc flash protection unit with combined current and arc sensing. When AQ-110FLV detects overcurrent in the incoming feeder and a light signal from a sub-unit or a direct light sensor, it minimizes the damage caused by an arcing fault (arc flash) by tripping the circuit breaker that sources the fault current. The complete system self-supervision function of AQ-110FLV provides the highest level of dependability by continuously monitoring all internal system functions as well as external connections.

HIGHLIGHTS:

- Connects to 3 fiber sensors.
- Has a superior isolation level against external disturbances - tested at the highest EMC classes.
- Has a trip time as fast as 2 ms.
- Trips up to 4 breakers.

PROTECTION

- Overcurrent (50Arc)
- Light (L>)
- Circuit breaker failure protection (50BF/52BF)
- Trip time when using mechanical trip relays: 7 ms*
- Reset time (arc light stage): 2 ms
- *) total trip time when using arc light (L>) and phase/residual overcurrent (I>) from an AQ-110xLV unit

I/O

Applicable sensors:

- AQ-06 plastic fiber sensor (3...40 m) (optional)
- AQ-07 glass fiber sensor (3...50 m) (optional)
- AQ-08 glass fiber sensor (3...15 m) (optional)

Trip relays (T1, T2, T3, T4)

- Number: 3 NO + 1 NC or 4 NO
- Rated voltage: 250 V AC/DC
- Continuous carry: 5 A
- Make-and-carry for 3 s: 16 A
- Make-and-carry for 0.5 s: 30 A
- Breaking capacity DC (when L/R = 40 ms): 40 W; 0.36 A at 110 V DC
- Contact material: AgNi 90/10

Binary output (BO1)

- Number of outputs: 1
- Rated voltage: +24 V DC
- Maximum rated current: 20 mA

Binary inputs (BI1, BI2)

- Number of inputs: 2
- Threshold voltage: 24 V DC
- Rated voltage: 250 V
- Rated current: 3 mA

Power supply

- Auxiliary power supply: 92...265 V AC/DC
- Auxiliary power supply: 18...72 V DC (optional)
- Maximum interruption: 100 ms
- Maximum power consumption: 5 W
- Standby current: 90 mA

HMI

- 18 indication LEDs
- Multifunction push button (SET)
- Autoconfiguration
- Indication reset
- System check

SELF-SUPERVISION

- Sensors and wiring
- Binary I/O
- Trip coil
- Power supply
- Internal voltages
- Settings
- CT connections

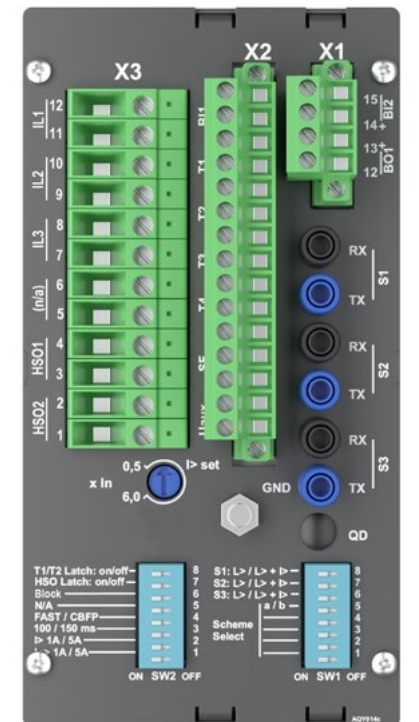

AQ-110FLV rear view



ORDER CODE

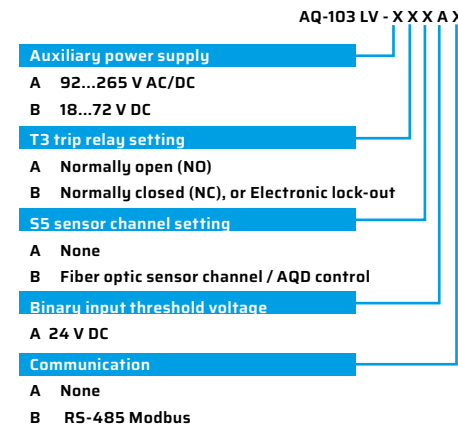

AQ-103LV Point sensor unit with Modbus



READ MORE

AQ-103LV is a sophisticated microprocessor-based arc flash protection unit with arc light detection. It acts as a sub-unit to an AQ-110PLV unit in an AQ 100 arc protection system. It can also function as a standalone unit in light-only systems. AQ-103LV is designed to minimize the damage caused by an arcing fault (arc flash) by tripping the circuit breaker that sources the fault current. The complete system self-supervision function of AQ-103LV provides the highest level of dependability by continuously monitoring all internal system functions as well as external connections. AQ-103LV provides communication through Modbus protocol.

HIGHLIGHTS:

- Connects to a maximum of 14 point sensors and 1 fiber sensor.
- Has a variant with Modbus communication.

PROTECTION

- Light (L>)
- Light and pressure (L> / P>)
- Circuit breaker failure protection (50BF/52BF)
- Trip time when using mechanical trip relays: 7 ms*
- Reset time (arc light stage): 2 ms
- *) total trip time when using arc light (L>) and phase/residual overcurrent (I>) from an AQ-110xLV unit

I/O

- Applicable sensors:**
- AQ-01 light sensor**
 - AQ-02 light and pressure sensor**
 - AQ-06 plastic fiber sensor (3...40 m) (optional)
 - AQ-07 glass fiber sensor (3...50 m) (optional)
 - AQ-08 glass fiber sensor (3...15 m) (optional)
- ***) Activation threshold options:**
8,000/25,000/50,000 lx
- Trip relays (T1, T2, T3, T4)**
- Number: 3 NO + 1 NC or 4 NO
 - Rated voltage: 250 V AC/DC
 - Continuous carry: 5 A
 - Make-and-carry for 3 s: 16 A
 - Make-and-carry for 0.5 s: 30 A
 - Breaking capacity DC (when L/R = 40 ms): 40 W; 0.36 A at 110 V DC
 - Contact material: AgNi 90/10

Binary output (BO1)

- Number of outputs: 1
- Rated voltage: +24 V DC
- Maximum rated current: 20 mA
- Binary inputs (BI1, BI2)

- Number of inputs: 2**
- Threshold voltage: 24 V DC
 - Rated voltage: 250 V
 - Rated current: 3 mA

Power supply

- Auxiliary power supply: 92...265 V AC/DC
- Auxiliary power supply: 18...72 V DC (optional)
- Maximum interruption: 100 ms
- Maximum power consumption: 5 W
- Standby current: 90 mA

HMI

- 25 indication LEDs
- Multifunction push button (SET)
- Autoconfiguration
- Indication reset
- System check

SELF SUPERVISION

- Sensors and wiring
- Binary I/O
- Trip coil
- Power supply
- Internal voltages
- Settings

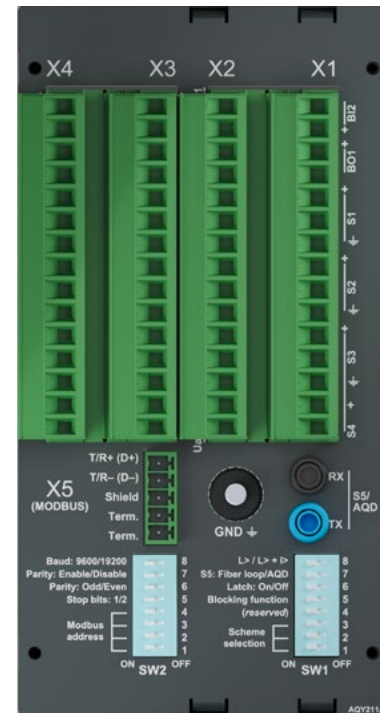

AQ-103LV rear view, Modbus variant



ORDER CODE

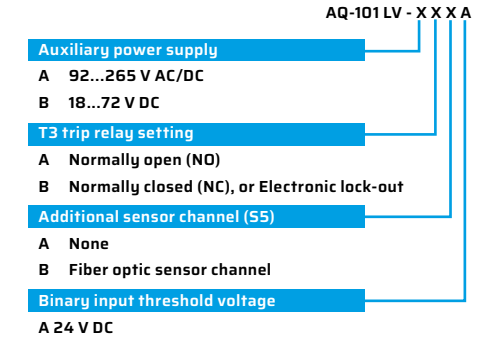

AQ-101LV Point sensor unit



READ MORE

AQ-101LV is a sophisticated microprocessor-based arc flash protection unit for arc light detection. It is designed to minimize the damage caused by an arcing fault (arc flash) by tripping the circuit breaker that sources the fault current. AQ-101LV acts as a sub-unit to an AQ-110PLV unit in an AQ 100 arc protection system. It can also function as a standalone unit in light-only systems.

The complete system self-supervision function of AQ-101LV provides the highest level of dependability by continuously monitoring all internal system functions as well as external connections.

HIGHLIGHTS:

- A practically unlimited number of units can be interconnected in one system.
- Standard Arc Schemes allow for fast engineering and simple setting.
- Connects to a maximum of 12 point sensors and 1 fiber sensor (optional).

PROTECTION

- Light (L>)
- Light and pressure (L> / P>)
- Circuit breaker failure protection (50BF/52BF)
- Trip time when using mechanical trip relays: 7 ms*
- Reset time (arc light stage): 2 ms
- *) total trip time when using arc light (L>) and phase/residual overcurrent (I>) from an AQ-110xLV unit

I/O

- Applicable sensors:**
- AQ-01 light sensor**
 - AQ-02 light and pressure sensor**
 - AQ-06 plastic fiber sensor (3...40 m) (optional)
 - AQ-07 glass fiber sensor (3...50 m) (optional)
 - AQ-08 glass fiber sensor (3...15 m) (optional)
- ***) Activation threshold options:**
8,000/25,000/50,000 lx
- Trip relays (T1, T2, T3, T4)**
- Number: 3 NO + 1 NC or 4 NO
 - Rated voltage: 250 V AC/DC
 - Continuous carry: 5 A
 - Make-and-carry for 3 s: 16 A
 - Make-and-carry for 0.5 s: 30 A
 - Breaking capacity DC (when L/R = 40 ms): 40 W; 0.36 A at 110 V DC
 - Contact material: AgNi 90/10

Binary output (BO1)

- Number of outputs: 1
- Rated voltage: +24 V DC
- Maximum rated current: 20 mA

Binary inputs (BI1, BI2)

- Number of inputs: 2
- Threshold voltage: 24 or 110 or 220 V DC
- Rated voltage: 250 V
- Rated current: 3 mA

Power supply

- Auxiliary power supply: 92...265 V AC/DC
- Auxiliary power supply: 18...72 V DC (optional)
- Maximum interruption: 100 ms
- Maximum power consumption: 5 W
- Standby current: 90 mA

HMI

- 12 indication LEDs
- Multifunction push button (SET)
- Autoconfiguration
- Indication reset
- System check

SELF SUPERVISION

- Sensors and wiring
- Binary I/O
- Trip coil
- Power supply
- Internal voltages
- Settings

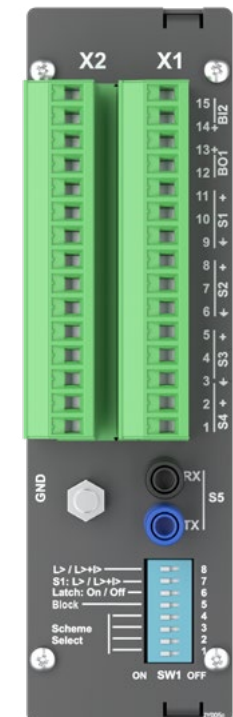

AQ-101LV rear view



AQ-101DLV Point sensor unit (DIN rail)



READ MORE

AQ-101DLV is a sophisticated microprocessor-based arc flash protection unit for arc light detection. It is designed to minimize the damage caused by an arcing fault (arc flash) by tripping the circuit breaker that sources the fault current. AQ-101DLV acts as a sub-unit to an AQ-110PLV unit in an AQ 100 arc protection system. It can also function as a standalone unit in light-only systems. The complete system self-supervision function of AQ-101DLV provides the highest level of dependability by continuously monitoring all internal system functions as well as external connections.

PROTECTION

- Light (L>)
- Light and pressure (L> / P>)
- Circuit breaker failure protection (50BF/52BF)
- Trip time when using mechanical trip relays: 7 ms*
- Reset time (arc light stage): 2 ms
- *) total trip time when using arc light (L>) and phase/residual overcurrent (I>) from an AQ-110xLV unit

I/O

- Applicable sensors:**
- AQ-01 light sensor**
 - AQ-02 light and pressure sensor**
 - AQ-06 plastic fiber sensor (3...40 m) (optional)
 - AQ-07 glass fiber sensor (3...50 m) (optional)
 - AQ-08 glass fiber sensor (3...15 m) (optional)
- **) Activation threshold options: 8,000/25,000/50,000 lx
- Trip relays (T1, T2, T3, T4)**
- Number: 3 NO + 1 NC or 4 NO
 - Rated voltage: 250 V AC/DC
 - Continuous carry: 5 A
 - Make-and-carry for 3 s: 16 A
 - Make-and-carry for 0.5 s: 30 A
 - Breaking capacity DC (when L/R = 40 ms): 40 W; 0.36 A at 110 V DC
 - Contact material: AgNi 90/10

Binary output (B01)

- Number of outputs: 1
- Rated voltage: +24 V DC
- Maximum rated current: 20 mA

Binary inputs (B11, B12)

- Number of inputs: 2
- Threshold voltage: 24 or 110 or 220 V DC
- Rated voltage: 250 V
- Rated current: 3 mA

Power supply

- Auxiliary power supply: 92...265 V AC/DC
- Auxiliary power supply: 18...72 V DC (optional)
- Maximum interruption: 100 ms
- Maximum power consumption: 5 W
- Standby current: 90 mA

HMI

- 12 indication LEDs
- Multifunction push button (SET)
- Autoconfiguration
- Indication reset
- System check

SELF SUPERVISION

- Sensors and wiring
- Binary I/O
- Trip coil
- Power supply
- Internal voltages
- Settings

ORDER CODE

- AQ-101 LV - X X X A
- Auxiliary power supply**
 - A 92...265 V AC/DC
 - B 18...72 V DC
 - T3 trip relay setting**
 - A Normally open (NO)
 - B Normally closed (NC), or Electronic lock-out
 - Additional sensor channel (S5)**
 - A None
 - B Fiber optic sensor channel
 - Binary input threshold voltage**
 - A 24 V DC

HIGHLIGHTS:

- Allows for easy DIN rail installation.
- Has 12 indication LEDs for fault analysis.

The complete system self-supervision function of AQ-101DLV provides the highest level of dependability by continuously monitoring all internal system functions as well as external connections.



AQ-102LV Fiber sensor unit



READ MORE

AQ-102LV is a sophisticated microprocessor-based arc flash protection unit for arc light detection. It has connectors for up to three fiber sensors. AQ-102LV is designed to minimize the damage caused by an arcing fault (arc flash) by tripping the circuit breaker that sources the fault current. AQ-102LV acts as a sub-unit to an AQ-110xLV unit in an AQ 100 arc protection system. It can also function as a standalone unit in light-only systems. The complete system self-supervision function of AQ-102LV provides the highest level of dependability by continuously monitoring all internal system functions as well as external connections.

PROTECTION

- Light (L>)
- Circuit breaker failure protection (50BF/52BF)
- Trip time when using mechanical trip relays: 7 ms*
- Reset time (arc light stage): 2 ms
- *) total trip time when using arc light (L>) and phase/residual overcurrent (I>) from an AQ-110xLV unit

I/O

- Applicable sensors:**
- AQ-06 plastic fiber sensor (3...40 m) (optional)
 - AQ-07 glass fiber sensor (3...50 m) (optional)
 - AQ-08 glass fiber sensor (3...15 m) (optional)

Trip relays (T1, T2, T3, T4)

- Number: 3 NO + 1 NC or 4 NO
- Rated voltage: 250 V AC/DC
- Continuous carry: 5 A
- Make-and-carry for 3 s: 16 A
- Make-and-carry for 0.5 s: 30 A
- Breaking capacity DC (when L/R = 40 ms): 40 W; 0.36 A at 110 V DC
- Contact material: AgNi 90/10

Binary output (B01)

- Number of outputs: 1
- Rated voltage: +24 V DC
- Maximum rated current: 20 mA

Binary inputs (B11, B12)

- Number of inputs: 2
- Threshold voltage: 24 or 110 or 220 V DC
- Rated voltage: 250 V
- Rated current: 3 mA

Power supply

- Auxiliary power supply: 92...265 V AC/DC
- Auxiliary power supply: 18...72 V DC (optional)
- Maximum interruption: 100 ms
- Maximum power consumption: 5 W
- Standby current: 90 mA

HMI

- 11 indication LEDs
- Multifunction push button (SET)
- Autoconfiguration
- Indication reset
- System check

SELF SUPERVISION

- Sensors and wiring
- Binary I/O
- Trip coil
- Power supply
- Internal voltages
- Settings

ORDER CODE

- AQ-102 LV - X X X A
- Auxiliary power supply**
 - A 92...265 V AC/DC
 - B 18...72 V DC
 - T3 trip relay setting**
 - A Normally open (NO)
 - B Normally closed (NC), or Electronic lock-out
 - Additional sensor channel**
 - A None
 - B AQD control
 - C Low fiber input sensitivity (S1-S3)
 - Binary input threshold voltage**
 - A 24 V DC

HIGHLIGHTS:

- Connects to a maximum of 3 fiber sensors.
- Has full self-supervision of all system components and interconnections.
- Adapts easily to any switchgear and trip scheme.

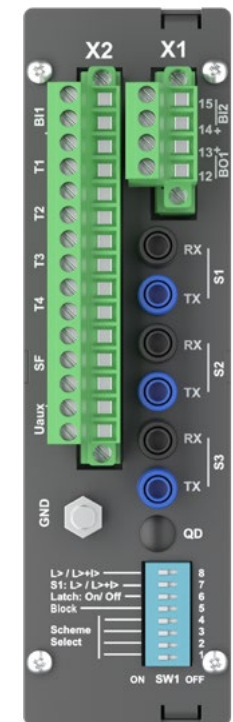

AQ-102LV rear view



AQ-1000 Quenching device



READ MORE

The AQ-1000 arc quenching device extinguishes arcing faults in systems with a rated voltage of below 690 V. AQ-1000 is designed to limit the total arcing time to less than 5 ms and to minimize (or even eliminate) the damaging effects caused by the arc fault's temperature and pressure. In most applications this will result in an energy release of less than 1.2 cal/cm². AQ-1000 can be re-activated, which allows for full system testing on-site.

The AQ-1000 arc quenching device is used in conjunction with an AQ 100 arc protection system. When an AQ 100 series unit detects a fault, it triggers the AQ-1000 arc quenching system and, at the same time, trips the circuit breaker(s) feeding the fault. Then AQ-1000 creates a three-phase, low-impedance parallel path for the fault current to flow through, thus extinguishing the arc fault.

TECHNICAL DATA

- Maximum rated voltage: 690 V
- Short-circuit withstand (IEC 60947-9-1/UL 2748): 100 kA for 200 ms, 50 kA for 1 s
- BIL: 12 kV
- Electric life: 2 operations at 100 kA, 200 ms each
- Mechanical life: 100 operations
- Total system operating time: less than 5 ms



PATENTED
US 9,318,294

ORDER CODE

AQ-1000 - X A	
Standard features	
Arc quenching device (690 V)	
Auxiliary power supply	
A	92...265 V AC/DC
B	18...72 V DC
Binary input threshold voltage	
A	24 V DC
Accessories	Order Code
Connection fiber (3 meters)	AX 0 0 1 - 3
Connection fiber (5 meters)	AX 0 0 1 - 5
Connection fiber (10 meters)	AX 0 0 1 - 10

HIGHLIGHTS:

- Mitigates the risk of injury during operations and maintenance.
- Minimizes damage to equipment.
- Is applicable to both new and retrofit installations.

Point sensors

Arcteq offers a variety of different arc sensor types to be used with different units and switchgear types, according to specific application requirements. The available point sensor types include a light-only point sensor as well as a point sensor that combines pressure and light detection. Additionally, Arcteq offers the AST-02 point sensor tester for field testing and commissioning purposes.

HIGHLIGHTS:

- Have a selectable light intensity threshold.
- Offer a unique combination of arc light and pressure.
- Allow for easy installation and full supervision.



AQ-01 - ARC LIGHT POINT SENSOR

- Three options for light intensity thresholds:
 - 8,000 lx
 - 25,000 lx
 - 50,000 lx
- Pick-up time: <1 ms
- Detection radius: 180 degrees
- Mechanical protection class: IP20
- A maximum of three sensors connected in series (except in AQ-103LV and AQ-103)
- Wiring arrangement: standard shielded twisted pair 0.75 mm²
- Operating temperature: -20...+85 °C



AQ-02 - ARC LIGHT AND PRESSURE POINT SENSOR

- Three options for light intensity thresholds:
 - 8,000 lx
 - 25,000 lx
 - 50,000 lx
- Pressure threshold: 0.2 bar above ambient pressure
- Pick-up time: <1 ms
- Detection radius: 180 degrees
- Mechanical protection class: IP20
- A maximum of three sensors connected in series (except in AQ-103LV and AQ-103)
- Wiring arrangement: standard shielded twisted pair 0.75 mm²
- Operating temperature: -20...+85 °C



AST-02 POINT SENSOR TESTER

- Arc sensor tester
- Local and remote control
- Auxiliary power supply: 80...265 V AC/DC
- Pressure input: 0.03...0.15 MPa (0.3...1.5 bar, 5...20 psi)
- Light intensity selection: 8/25/50 klx
- Activation time setting: 50/120/170 ms

Fiber sensors

Fiber sensors make sure that each compartment in the switchgear has full light supervision. The fiber can be made of plastic or multithread glass fiber. Furthermore, the glass fiber can be specifically made to tolerate higher temperatures. All fiber sensors have a light intensity threshold of 8,000 lux.

HIGHLIGHTS:

- A detection radius of 360°.
- Glass fiber sensors have a bending radius of 1 cm.
- The maximum fiber length is 50 meters (AQ-07).



AQ-06 - ARC LIGHT FIBER SENSOR (PLASTIC)

- Material: plastic fiber
- Light intensity threshold: 8,000 lx
- Detection radius: 360 degrees
- Bending radius: 5 cm
- Maximum fiber length: 40 m
- Operating temperature: -40...+85 °C

AQ-07 - ARC LIGHT FIBER SENSOR (GLASS)

- Material: covered glass fiber
- Light intensity threshold: 8,000 lx
- Detection radius: 360 degrees
- Bending radius: 1 cm
- Maximum fiber length: 50 m
- Operating temperature: -40...+85 °C

AQ-08 - ARC LIGHT FIBER SENSOR (GLASS, HIGH TEMPERATURE)

- Material: covered glass fiber
- Light intensity threshold: 8,000 lx
- Detection radius: 360 degrees
- Bending radius: 1 cm
- Maximum fiber length: 15 m
- Operating temperature: -40...+125 °C

Raising frame

When using a raising frame for installing an AQ 100 series protection device to a cabinet door, it leaves additional room for other installation equipment in the space behind the door. We offer raising frames of 40 mm to both AQ-110x and AQ-10x products.



40 mm raising frame for AQ-110x products.



40 mm raising frame for AQ-10x products.

Sensor mounting bracket

The sensor mounting bracket can be mounted in the required position of the sensor. After that it is easy to snap in the sensor, facing either direction.



Front view



Back view

SELECTION TABLE

SELECTION TABLE	AQ-110P	AQ-110F	AQ-103	AQ-101	AQ-101D	AQ-101S	AQ-102	AQ-110PLV	AQ-110FLV	AQ-103LV	AQ-101LV	AQ-101DLV	AQ-102LV
Wide power supply range (18...72 V DC or 92...265 V AC/DC)	•	•	•	•	•	•	•	•	•	•	•	•	•
Mounting	Panel/rack	Panel/rack	Panel/rack	Panel/rack	DIN rail	Panel/rack	Panel/rack	Panel/rack	Panel/rack	Panel/rack	Panel/rack	DIN rail	Panel/rack
Three-phase current detection (1/5 A)	•	•						•	•				
Residual current detection (1/5 A)	•	•											
Maximum number of point sensors	12		14	12	12	12		12		14	12	12	
Maximum number of fiber loop sensors	1 (optional)	3	1 (optional)	1 (optional)	1 (optional)		3	1 (optional)	3	1 (optional)	1 (optional)	1 (optional)	3
Connectivity to arc quenching systems	•	•	•	•	•	•	•	•	•	•	•	•	•
High-speed outputs (2 ms trip time)	2	2	1					2	2	1			
Number of trip relays (7 ms trip time)*	4	4	4	4	4	3	4	4	4	4	4	4	4
System failure (SF) relay	•	•	•	•	•	•	•	•	•	•	•	•	•
Binary outputs (24 V DC)	1	1	1	1	1	3	1	1	1	1	1	1	1
Binary inputs (24/110/220 V DC**)	2	2	2	2	2	6	2	2	2	2	2	2	2
Modbus communication		optional								optional			
Push button	•	•	•	•	•	•	•	•	•	•	•	•	•
Non-volatile memory	•	•	•	•	•	•	•	•	•	•	•	•	•
Indication LEDs	20	19	25	12	12	17	11	19	18	25	12	12	11
APPLICABLE SENSORS													
AQ-01 light sensor (a, b, c***)	•		•	•	•	•		•		•	•	•	
AQ-02 light and pressure sensor	•		•	•	•	•		•		•	•	•	
AQ-06 plastic fiber loop sensor (3...40 m)	optional	•	optional	optional	optional		•	optional	•	optional	optional	optional	•
AQ-07 glass fiber loop sensor (3...50 m)	optional	•	optional	optional	optional		•	optional	•	optional	optional	optional	•
AQ-08 glass fiber loop sensor (high temperatures, 3...15 m)	optional	•	optional	optional	optional		•	optional	•	optional	optional	optional	•

*) Optionally, one of the trip relays can be selected to be normally closed (NC) / electronic lock-out.

**) Please note that for both AQ-110x variants (MV) and both AQ-103 variants (MV) the threshold voltage of binary inputs can only be 24 V DC.

***) Activation threshold options: a = 8,000 lx, b = 25,000 lx, c = 50,000 lx.

Protection	
Trip time using HSO	2 ms*
Trip time using mechanical trip relays	7 ms*
Reset time:	
arc light stage	1 ms
overcurrent stages	50 ms

*) The total trip time using only arc light (L>) or using both overcurrent (I>) and arc light (L>).

Auxiliary voltage	
Auxiliary power supply	92...265 V AC/DC 18...72 V DC (optional)
Maximum interruption	100 ms
Maximum power consumption	5 W, <10 mΩ
Standby current	90 mA

Trip Relays (T1, T2, T3, T4)	
Number of trip relays	4 NO or 3 NO + 1 NC
Voltage withstand	250 V AC/DC
Carry:	
Continuous carry	5 A
Make-and-carry for 3 s	16 A
Make-and-carry for 0.5 s	30 A
Breaking capacity DC*	40 W (0.36 A at 110 V DC)
Contact material	AgNi 90/10

*) When the time constant L/R = 40 ms.

High-speed outputs (HS01, HS02)	
Number of high-speed outputs	2
Rated voltage	250 V DC
Carry:	
Continuous carry	2 A
Make-and-carry for 3 s	6 A
Make-and-carry for 0.5 s	15 A
Breaking capacity DC*	1 A / 110 W
Contact material	Semiconductor

*) When the time constant L/R = 40 ms.

System failure (SF) relay	
Number of SF relays	1
Rated voltage	250 V AC/DC
Carry:	
Continuous carry	5 A
Make-and-carry for 3 s	16 A
Make-and-carry for 0.5 s	30 A
Breaking capacity DC*	40 W (0.36 A at 110 V DC)
Contact material	AgNi 90/10

*) When the time constant L/R = 40 ms.

Binary output (BO1)	
Number of binary outputs	1
Rated voltage	+24 V DC
Maximum rated current	20 mA

Binary outputs (BI1, BI2)	
Number of binary inputs	2
Nominal threshold voltage	24/110/220 V DC*
Maximum rated current	3 mA
Threshold:	
pick-up	≥16 V DC
drop-off	≤15 V DC

*) Please note that the rated voltage options depend on the model (both AQ-110x variants and all LV models only have one option, 24 V DC).

Point sensors (AQ-01 & AQ-02)	
Light intensity threshold	8,000 lx 25,000 lx 50,000 lx
Pressure threshold (fixed) (only AQ-02!)	0.2 bar above ambient temperature
Pressure measuring accuracy (only AQ-02!)	±1.8 % (of full scale)
Detection radius	180°
Mechanical protection	IP 20
Sensor cable specification	Shielded twisted pair 0.75 mm ² (AWG: 20)
Maximum sensor cable length (per channel)	200 m
Operating temperature	-20...+85 °C

Fiber sensors (AQ-06, AQ-07 & AQ-08)	
Material	Plastic fiber (AQ-06) Covered glass fiber (AQ-07 & AQ-08)
Light intensity threshold	8,000 lx
Cable length (min...max)	3...40 m (AQ-06) 3...50 m (AQ-07) 3...15 m (AQ-08)
Cable diameter	1.0 mm (AQ-06) 1.2 mm (AQ-07 & AQ-08)
Detection radius	360°
Bending radius	5 cm (AQ-06) 1 cm (AQ-07 & AQ-08)
Operating temperature	-40...+85 °C (AQ-06 & AQ-07) -40...+125 °C (AQ-08)

DISTURBANCE TESTS	
Electromagnetic compatibility (EMC) test (EN 60255-26)	CE-tested and approved
Emission tests:	
Conducted (EN 55011 class A / CISPR22)	0.15...30 MHz
Emitted (EN 55011 class A / CISPR11)	30...1,000 MHz
Immunity tests:	
Static discharge (ESD) test (EN 60255-22-2 and EN 61000-4-2, severity class 4)	Air discharge: 15 kV Contact discharge: 8 kV
Fast transients (EFT) test (EN 61000-4-4, class III & EN 60255-22-4, level 4)	Power supply input: 4 kV, 5/50 ns Other inputs and outputs: 4 kV, 5/50 ns
Surge test (EN 61000-4-5, level 4 & EN 60255-22-5)	Between wires: 2 kV/1.2/50 μs Between wire and ground: 4 kV/1.2/50 μs
RF electromagnetic field test (EN 61000-4-3, class III)	f = 80...1,000 MHz, 10 V/m
Conducted RF field test (EN 61000-4-6, class III)	f = 150 kHz...80 MHz, 10 V

VOLTAGE TESTS	
Insulation test voltage (IEC 60255-5)	2 kV, 50 Hz, 1 min
Impulse test voltage (EN 60255-5)	5 kV, 1.2/50 μs, 0.5 J

MECHANICAL TESTS	
Vibration test (IEC 60255-21-1)	2...13.2 Hz (±3.5 mm) 13.2...100 Hz (±1.0 g)
Shock/bump test (IEC 60255-21-2)	20 g, 1,000 bumps/dir.

ENVIRONMENTAL CONDITIONS	
Specified ambient service temperature range	-35...+70 °C
Transport and storage temp. range	-40...+70 °C
Relative humidity	Up to 97%
Altitude	Up to 2,000 m above sea level

DEVICE CASING AND DIMENSIONS	
Protection:	
front	IP 50
back	IP 20
Device dimensions (W × H × D):	
AQ-103, AQ-110x	102 × 177 × 175 mm
AQ-101(S), AQ-102	50 × 177 × 175 mm
AQ-101D	145 × 110 × 34 mm
AQ-1000	322 × 256 × 352 mm
SIQuench 3AM4132	580 × 290 × 539.5 mm
SIQuench 3AM4143	740 × 290 × 539.5 mm

Certificates



Wiring diagram example

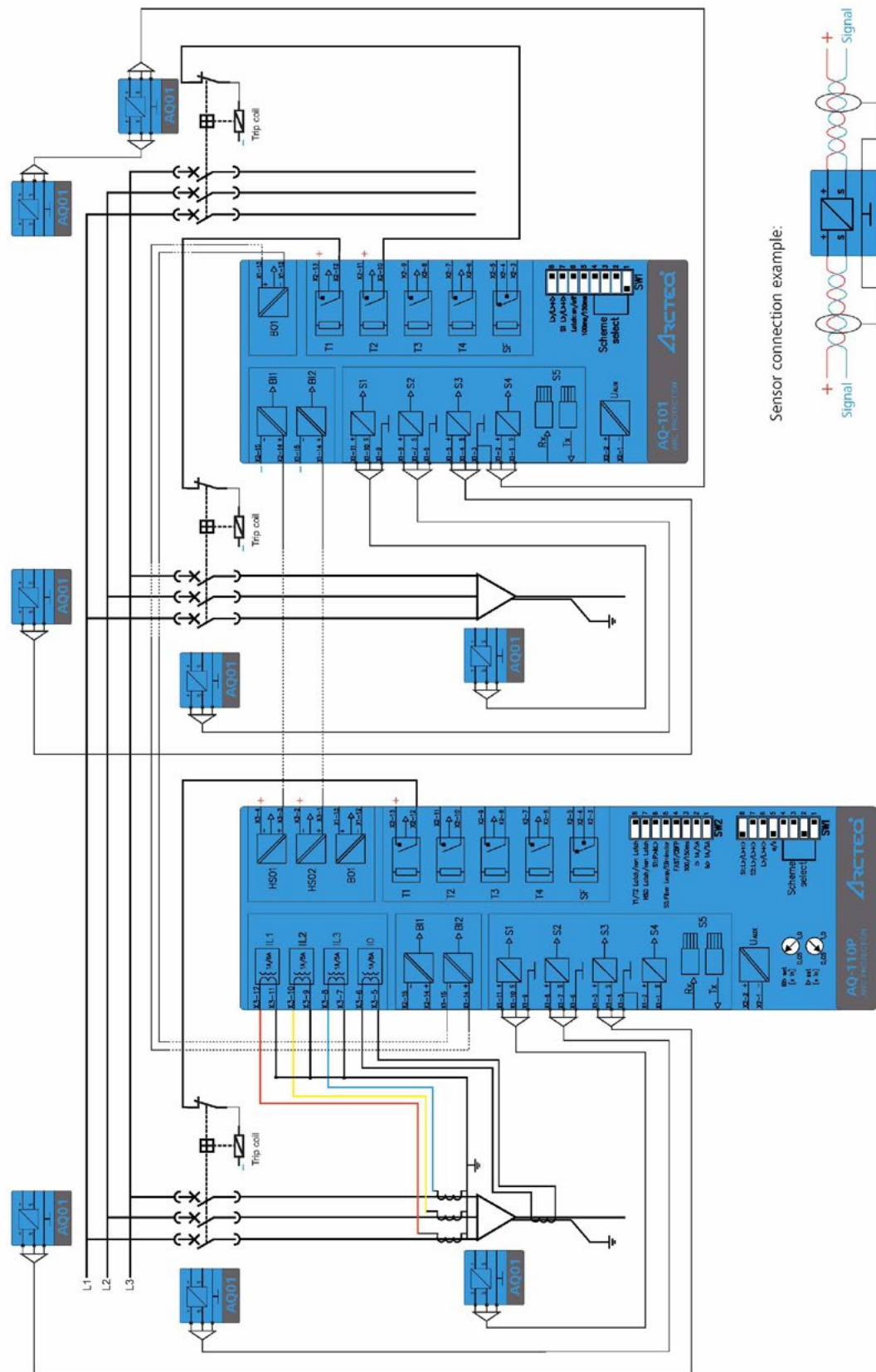

Sensor connection example:

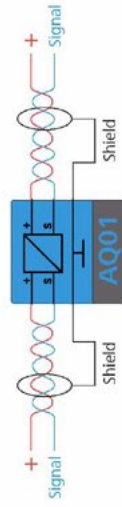

This typical AQ 100 series wiring diagram illustrates the wiring of an AQ-110x main unit and an AQ-101 sub-unit, with measurements of the three phase currents and the residual current.

AQ-103 & AQ-110X

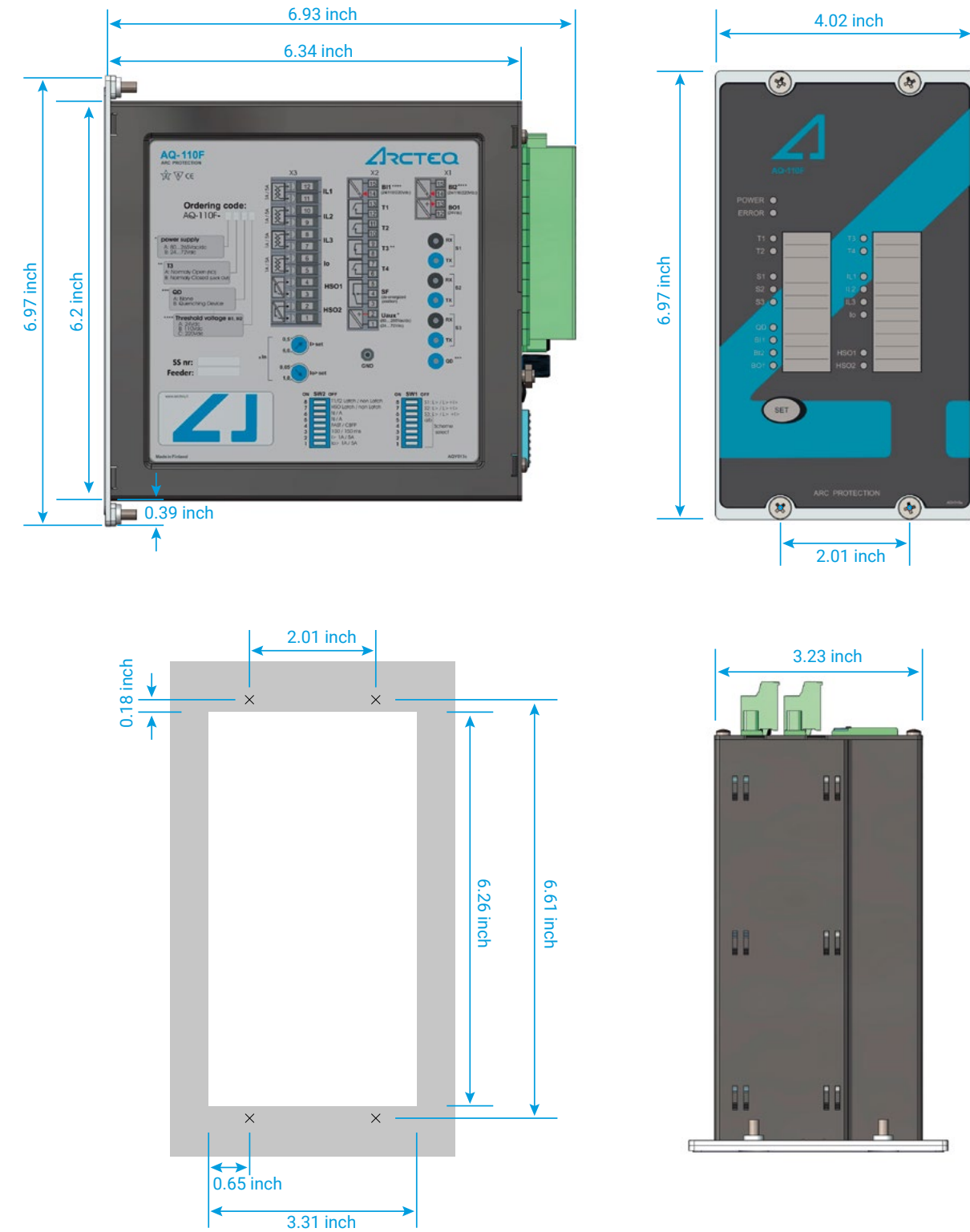

The dimensions of AQ-103 and AQ-110x units (both MV and LV variants): side view (top left), front view (top right), top view (bottom right); the panel cut-out and its dimensions (bottom left).

AQ-101, AQ-101S & AQ-102

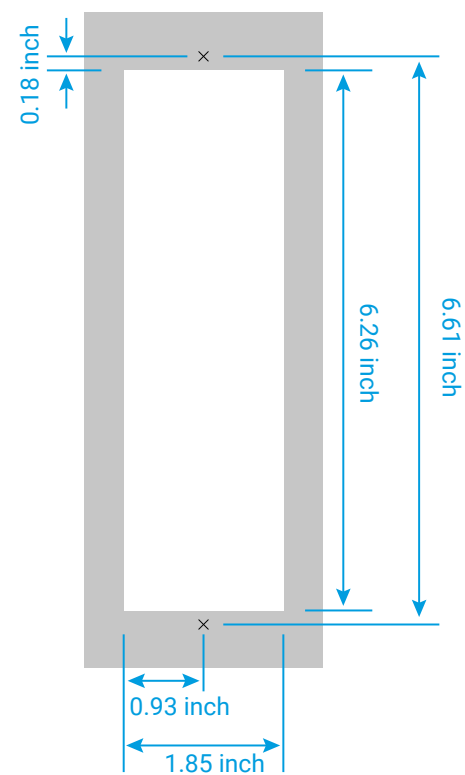
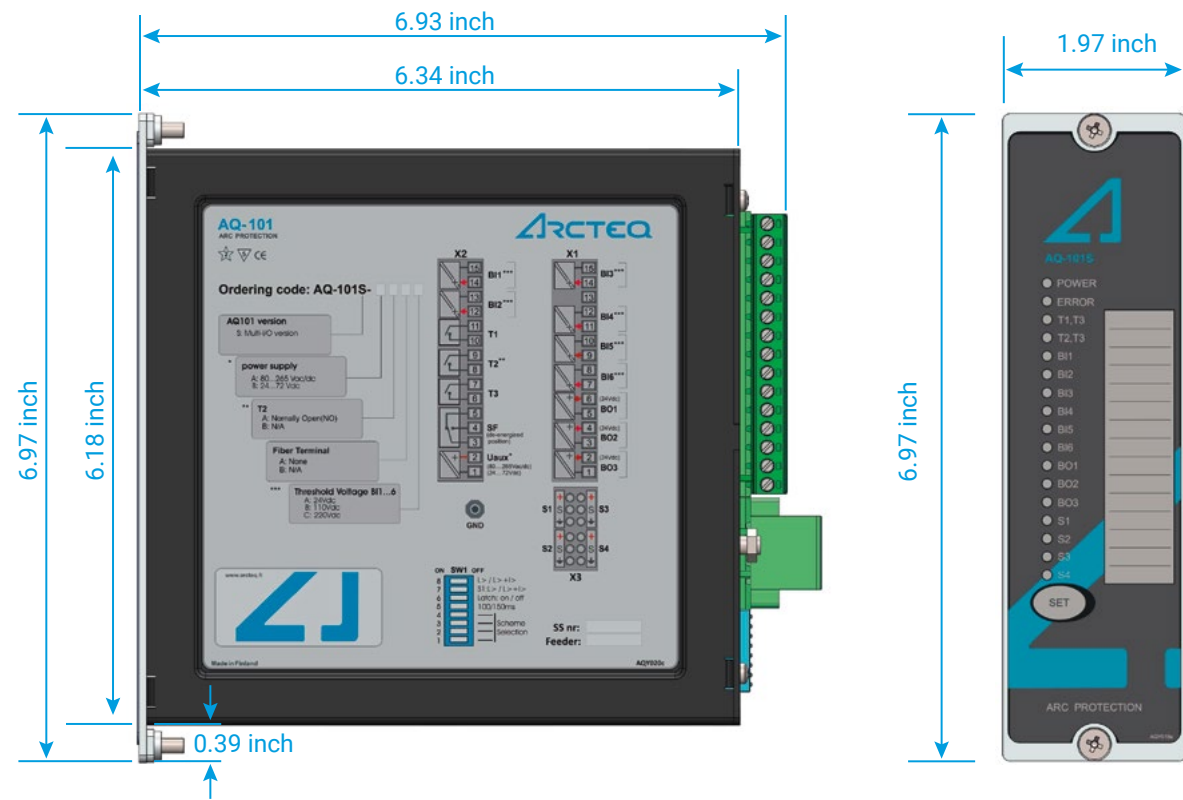

The dimensions of AQ-101, AQ-101S and AQ-102 units (both MV and LV variants): side view (top left), front view (top right), top view (bottom right); the panel cut-out and its dimensions (bottom left).



AQ-101D

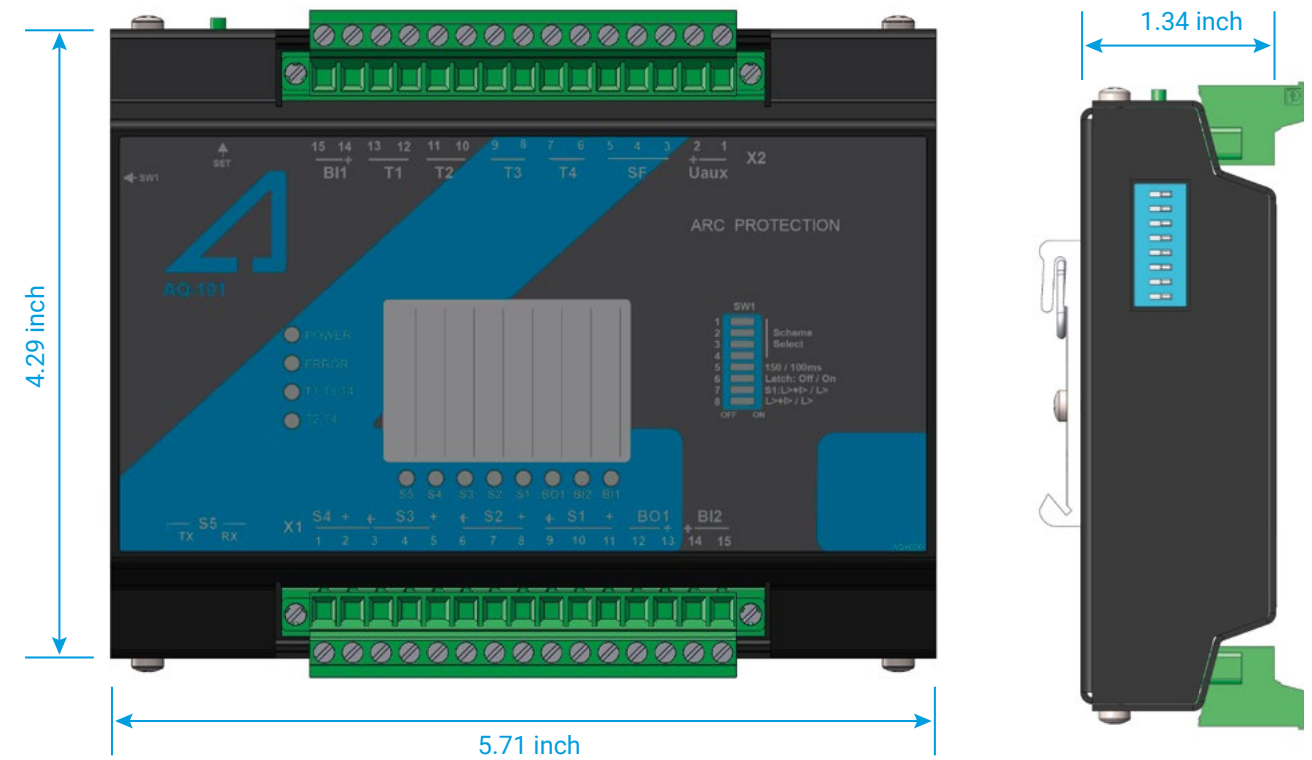

The dimensions of AQ-101D (both MV and LV variants): front view (left), side view (right).

ENSTO NORTH AMERICA INC.

4500 S. Hardin Blvd.
Suite 460
McKinney, TX 75070, USA
tel: +1 (972) 369-7788

MAIL INQUIRIES:

Sales.US@arcteq.com

TECHNICAL SUPPORT:

arcteq.com/support

ARCTEQ SUPPORT LINE:

+358 10 3221 388
EET 9:00 - 17.00

ARCTEQ HEADQUARTERS

Arcteq Relays Ltd
Kvartsikatu 2 A 1
65300 Vaasa, Finland
Business ID: 2342569-3
tel: +358 10 3221 370

