

AQ 100 (Siemens)

Arc flash protection (AQ-101, AQ-101D, AQ-110P, AQ-1000, AQ-01, AQ-02)

Instruction manual



Table of contents

1 Important document information.....	5
2 Revision history	6
3 Abbreviations	7
4 Installation.....	8
4.1 Mechanical installation.....	8
4.1.1 Door mounting	8
4.1.2 DIN rail mounting.....	9
4.1.3 Installation of the AQ-1000 arc quenching device	9
4.1.4 Installation of arc flash sensors	11
4.2 Wiring.....	12
4.2.1 AQ-101 and AQ-101D arc flash protection relays.....	12
4.2.2 AQ-110P arc flash protection relay with overcurrent	14
4.2.3 AQ-1000 arc quenching device (LV).....	16
4.2.4 AQ-01 and AQ-02 arc sensors.....	18
5 Configuration	19
5.1 DIP switches.....	19
5.1.1 AQ-101 and AQ-101D	19
5.1.2 AQ-110P.....	20
5.2 Potentiometers	21
5.3 Protection scheme logics.....	22
5.3.1 AQ-101 and AQ-101D	22
5.3.2 AQ-110P.....	24
5.3.3 I/O description	28
6 Operation.....	29
6.1 Operation of an arc flash protection relay	29
6.1.1 LED indicators	29
6.1.2 Text pocket.....	31
6.1.3 SET button	32
6.2 Operation of an arc quenching device.....	33
6.2.1 LED indicators	33
6.2.2 Operating modes.....	35
6.2.3 Binary input functions	36
6.2.4 SET button	36
6.2.5 Resetting the quencher after a trip.....	37
6.3 Sensor operation	38
7 Commissioning of arc flash relays.....	40
7.1 System installation	40
7.2 Current measurement.....	40
7.3 Light channel activation	41
7.4 Activation of outputs (tripping)	42
7.5 Testing.....	42
8 Commissioning of AQ-1000	43
9 Arc protection applications	44
9.1 Low-voltage arc protection applications	44
9.1.1 One incomer	44
9.1.2 Two incomers without a tie breaker	45
9.1.3 Two incomers with a tie breaker (shared L>)	46
9.1.4 Two incomers with a tie breaker (shared I>)	47
9.2 Medium-voltage arc protection applications	48
9.2.1 One incomer (feeder selective)	48
9.2.2 Two incomers without a tie breaker (feeder selective).....	49
9.2.3 One incomer (non-feeder selective)	50
9.2.4 Two incomers without a tie breaker (non-feeder selective).....	51
9.2.5 Two incomers with a tie breaker	52
10 Troubleshooting.....	53

11 Technical data	54
11.1 Technical data of AQ-101, AQ-101D and AQ-110P	54
11.1.1 Mounting and installation	54
11.1.2 Operating times	54
11.1.3 Auxiliary voltage	55
11.1.4 Current measurement circuits	55
11.1.5 Trip relays	55
11.1.6 High-speed outputs	56
11.1.7 Binary output	56
11.1.8 Binary inputs	56
11.2 AQ-1000 arc quenching device	57
11.2.1 Mounting and installation	57
11.2.2 Device ratings	57
11.2.3 Auxiliary voltage	58
11.2.4 Signal relays	58
11.2.5 Binary inputs	59
11.2.6 Environmental ratings	59
11.3 Arc flash sensors	60
12 Dimensions	61
12.1 AQ-101, AQ-101D and AQ-110P	61
12.2 AQ-1000 arc quenching device	65
12.3 Arc flash sensors	69
13 Order codes	70
14 Reference information	73

Disclaimer

Please read these instructions carefully before using the equipment or taking any other actions with respect to the equipment. Only trained and qualified persons are allowed to perform installation, operation, service or maintenance of the equipment. Such qualified persons have the responsibility to take all appropriate measures, including e.g. use of authentication, encryption, anti-virus programs, safe switching programs etc. necessary to ensure a safe and secure environment and usability of the equipment. The warranty granted to the equipment remains in force only provided that the instructions contained in this document have been strictly complied with.

Nothing contained in this document shall increase the liability or extend the warranty obligations of the manufacturer Arcteq Relays Ltd. The manufacturer expressly disclaims any and all liability for any damages and/or losses caused due to a failure to comply with the instructions contained herein or caused by persons who do not fulfil the aforementioned requirements. Furthermore, the manufacturer shall not be liable for possible errors in this document.

Please note that you must always comply with applicable local legislation and regulations. The manufacturer gives no warranties that the content of this document is in all respects in line with local laws and regulations and assumes no liability for such possible deviations.

You are advised to notify the manufacturer in case you become aware of any errors in this document or of defects in the equipment.

The manufacturer reserves the right to update or amend this document at any time.

Copyright

Copyright © Arcteq Relays Ltd. 2022. All rights reserved.

1 Important document information

This manual is a combination of two or more individual product manuals that have been published in English, abbreviating much of their content. As such, the purpose of this manual is to give a general overview of the "Certified for Siemens" version of the AQ 100 series product family. For more detailed information of the individual units please refer to their respective manuals. These manuals can be found at <https://www.arcteq.fi/documents-and-software/>.

Please note that the individual product manuals in English are the master documents. If there is a discrepancy between the information given in this manual and the information given in the individual manuals, always defer to the English manuals as they are updated more frequently.

2 Revision history

Table. 2 - 1. History of Revision 1.

Revision	1.00
Date	December 2021
Changes	(N/A)
Revision	1.01
Date	September 2022
Changes	Updated the "Device ratings" chapter

NOTE!

This manual combines two previous Siemens manuals (one for MV products and the other for LV products). The following changes have been made to the contents during the combining process:

- visual overhaul
- added the master document reference to the "Important document information" chapter
- added more abbreviation explanations to the "Abbreviations" chapter
- added asterisk explanations to Figure 4.1.1 and to scheme tables
- added chapter references
- all images (apart from application examples) upgraded for additional clarity and correctness
- the "Arc protection applications" chapter divided into MV and LV applications
- added the MV applications
- due to some applications being named the same, they are differentiated by adding to the titles (whether they are feeder selective or not) as well as having a note that further explains the difference
- some terminology changes: "dipswitch" --> "DIP switch", "QD" --> "AQD"
- scheme table error fixed
- separated the front panel images from their respective LED indicator tables
- LED indicator tables for AQ-1000 corrected
- AQ-1000's "CLEAR button" corrected to "SET button"
- corrected the AQ-1000's X1 wiring descriptions for pins 9-10-11
- added the "Light channel activation" subchapter to the "Relay commissioning" chapter
- fixed the "Troubleshooting" table to include all units, and changed "IF relay state" to "SF relay state"
- the contents of the "Technical data" chapter updated where necessary
- added the order code for the AQ-1000 reset handle

3 Abbreviations

AQD – arc quenching device (in accordance with IEC 60947-9-1)

BI – binary input

BIL – basic insulation level

BO – binary output

CBFP – circuit breaker failure protection

CT – current transformer

GND – ground

HSO – high-speed output

I> – overcurrent signal

IL – phase current

I0 – neutral sequence current

L> – light signal

LED – light emitting diode

MT – master trip signal

NC – normally closed

NO – normally open

Rx – receiver

SF – self-supervision

Tx – transmitter

4 Installation

4.1 Mechanical installation

4.1.1 Door mounting

Figure. 4.1.1 - 1. Installing a relay to a door.

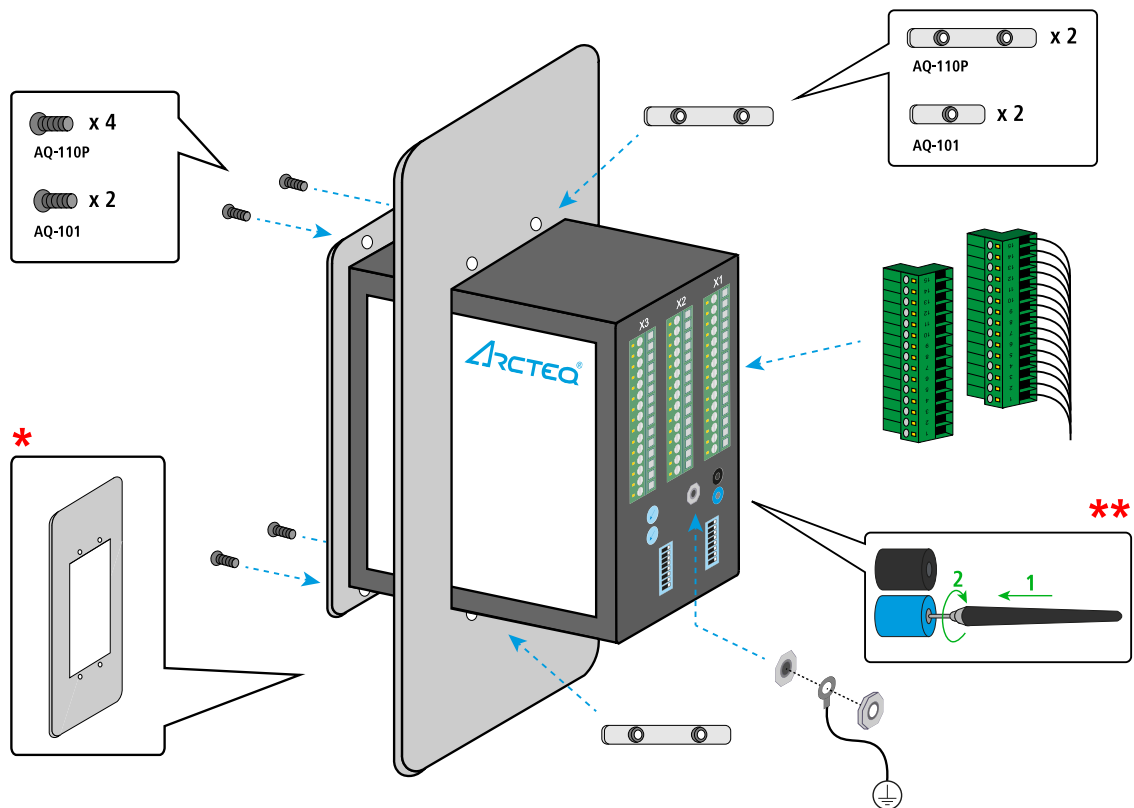

*) See the panel cut-out's dimensions in the separate cut-out sheet in Chapter 12.1 in the "Dimensions" chapter.

***) Fiber sensors are optional for AQ-101, AQ-101D and AQ-110P. See Chapter 13 ("Order codes").

4.1.2 DIN rail mounting

Figure. 4.1.2 - 2. Installing a relay to a DIN rail.

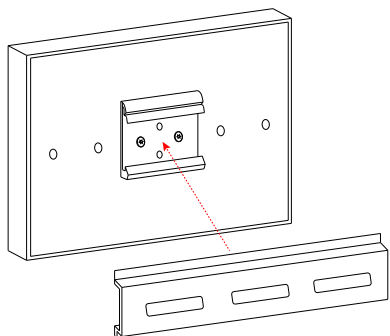

4.1.3 Installation of the AQ-1000 arc quenching device

NOTE!



For details on technical information regarding the installation please refer to Chapter 11.2.1 of the "Technical data" chapter.

Figure. 4.1.3 - 3. AQ-1000 installation (tray assembly).

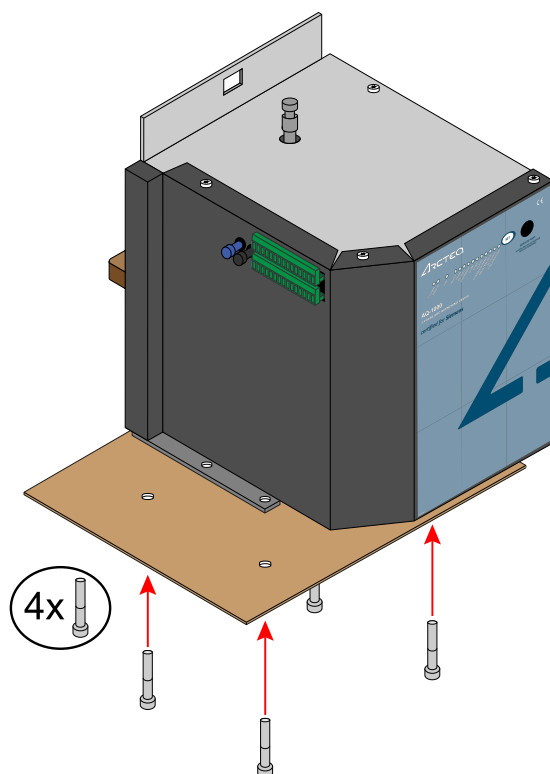
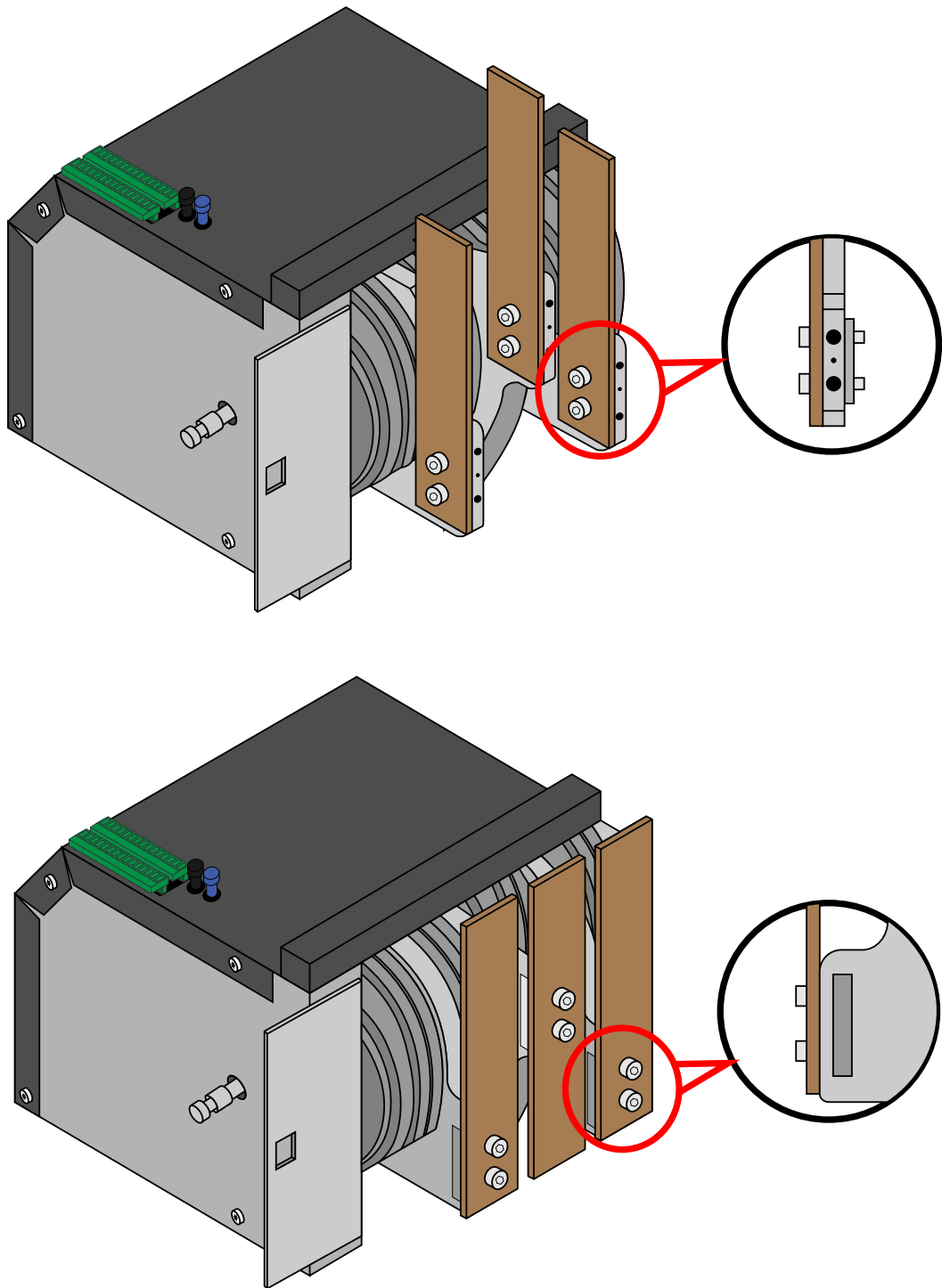

Figure. 4.1.3 - 4. AQ-1000 installation (busbar mounting alternatives).



WARNING!



Busbar sizing and clearance distances must follow both the switchgear ratings and the maximum short circuit current value!

4.1.4 Installation of arc flash sensors

Figure. 4.1.4 - 5. Installing an arc flash sensor.

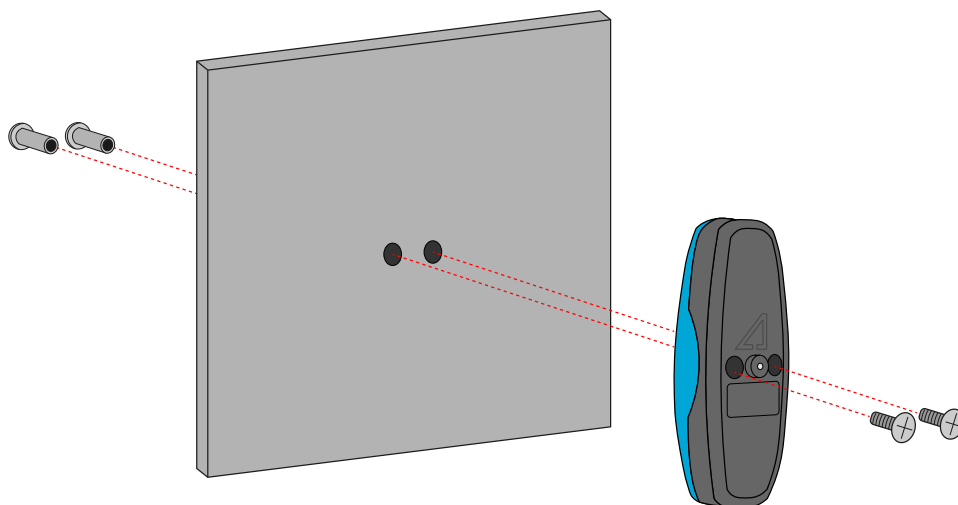

NOTE!



Although the image above depicts the installation of an AQ-01 point sensor, please note that an AQ-02 pressure and point sensor is installed in the same way.

4.2 Wiring

4.2.1 AQ-101 and AQ-101D arc flash protection relays

Table 4.2.1 - 2. Descriptions for X1 of AQ-101(D).

X1	Pin no.	Function
<p>The diagram shows a 15-pin terminal block labeled X1. The pins are numbered 1 to 15 from bottom to top. They are grouped into six sections: B12 (pins 14 and 15), BO1 (pins 12 and 13), S1 (pins 9, 10, and 11), S2 (pins 6, 7, and 8), S3 (pins 3, 4, and 5), and S4 (pins 1 and 2). Each S section has a '+' sign above the top pin and an 'S' sign above the bottom pin. Pin 3 has a ground symbol below it. Pin 15 has a diagonal slash and a star symbol next to it.</p>	15	Binary input 2 – negative
	14	Binary input 2 – positive
	13	Binary output 1 – +24 V DC
	12	Binary output 1 – GND output
	11	Sensor channel 1 – supply
	10	Sensor channel 1 – signal
	9	Sensor channel 1 – ground
	8	Sensor channel 2 – supply
	7	Sensor channel 2 – signal
	6	Sensor channel 2 – ground
	5	Sensor channel 3 – supply
	4	Sensor channel 3 – signal
	3	Sensor channels 3 and 4 – ground
	2	Sensor channel 4 – supply
	1	Sensor channel 4 – signal

Table. 4.2.1 - 3. Descriptions for X2 of AQ-101(D).

X2	Pin no.	Function
	15	Binary input 1 – negative
	14	Binary input 1 – positive
	13	Trip contact T1
	12	Trip contact T1
	11	Trip contact T2
	10	Trip contact T2
	9	Trip contact T3*
	8	Trip contact T3*
	7	Trip contact T4
	6	Trip contact T4
	5	Self-supervision contact – normal
	4	Self-supervision contact – failure
	3	Self-supervision contact – common
	2	Power supply – positive
	1	Power supply – negative

*) Trip contact T3 may be normally open or normally closed type; see Chapter 13 ("Order codes").

Table. 4.2.1 - 4. Descriptions for S5 of AQ-101(D).

S5	Name	Function
	Rx	Sensor 5 – receiver**
	Tx	Sensor 5 – transmitter**

**) Sensor S5 is optional for fiber sensor; see Chapter 13 ("Order codes").

NOTE!



See rated voltages and connector tightening torques in Chapter 11.1.1 of the "Technical data" chapter.

4.2.2 AQ-110P arc flash protection relay with overcurrent

Table. 4.2.2 - 5. Descriptions for X1 of AQ-110P.

X1	Pin no.	Function
	15	Binary input 2 – negative
	14	Binary input 2 – positive
	13	Binary output 1 – +24 V DC
	12	Binary output 1 – GND output
	11	Sensor channel 1 – supply
	10	Sensor channel 1 – signal
	9	Sensor channel 1 – ground
	8	Sensor channel 2 – supply
	7	Sensor channel 2 – signal
	6	Sensor channel 2 – ground
	5	Sensor channel 3 – supply
	4	Sensor channel 3 – signal
	3	Sensor channels 3 and 4 – ground
	2	Sensor channel 4 – supply
	1	Sensor channel 4 – signal

Table. 4.2.2 - 6. Descriptions for X2 of AQ-110P.

X2	Pin no.	Function
	15	Binary input 1 – negative
	14	Binary input 1 – positive
	13	Trip contact T1
	12	Trip contact T1
	11	Trip contact T2
	10	Trip contact T2
	9	Trip contact T3*
	8	Trip contact T3*
	7	Trip contact T4
	6	Trip contact T4
	5	Self-supervision contact – normal
	4	Self-supervision contact – failure
	3	Self-supervision contact – common
	2	Power supply – positive
	1	Power supply – negative

*) Trip contact T3 may be normally open or normally closed type; see Chapter 13 ("Order codes").

Table. 4.2.2 - 7. Descriptions for X3 of AQ-110P.

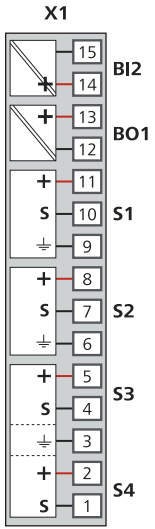
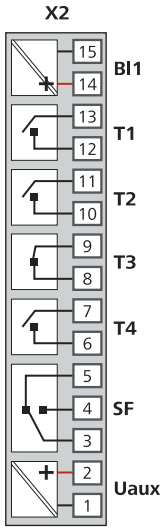
X3	Pin no.	Function
	12	Current measurement input – L1
	11	Current measurement input – L1
	10	Current measurement input – L2
	9	Current measurement input – L2
	8	Current measurement input – L3
	7	Current measurement input – L3
	6	Current measurement input – I0
	5	Current measurement input – I0
	4	High-speed output 1 – voltage in
	3	High-speed output 1 – voltage out
	2	High-speed output 2 – voltage in
	1	High-speed output 2 – voltage out

Table. 4.2.2 - 8. Descriptions for S5 of AQ-110P.

S5	Name	Function
	Rx	Sensor 5 – receiver**
	Tx	Sensor 5 – transmitter**

**) Sensor S5 is optional for fiber sensor or quenching device control; see Chapter 13 ("Order codes").

Figure. 4.2.2 - 6. HSO connection example.

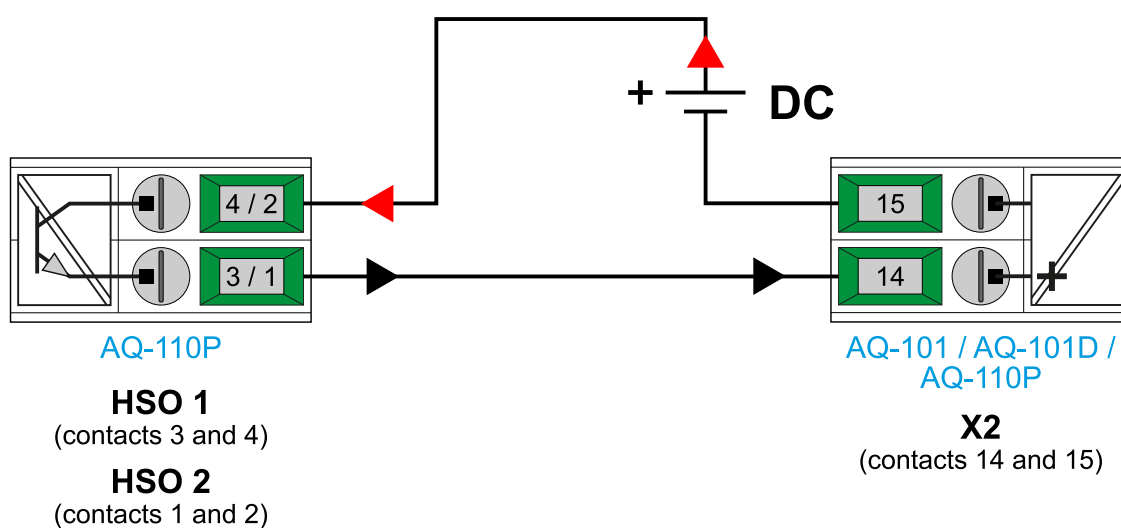

WARNING!



Always ensure that current measurement circuits are not energized during disconnection!

NOTE!



See rated voltages and connector tightening torques in Chapter 11.1.1 of the "Technical data" chapter.

4.2.3 AQ-1000 arc quenching device (LV)

Table. 4.2.3 - 9. Descriptions of X1 of AQ-1000.

X1	Pin no.	Function
	1	Binary input 1 – positive (clear)
	2	Binary input 1 – negative (clear)
	3	Binary input 2 – positive (Commissioning mode)
	4	Binary input 2 – negative (Commissioning mode)
	5	Binary input 3 – positive (not in use)
	6	Binary input 3 – negative (not in use)
	7	Binary input 4 – positive (blocking function)
	8	Binary input 4 – negative (blocking function)
		<i>(not connected)</i>
		<i>(not connected)</i>
		<i>(not connected)</i>
		<i>(not connected)</i>
		<i>(not connected)</i>
		<i>(not connected)</i>
		<i>(not connected)</i>

Table. 4.2.3 - 10. Descriptions of X2.

X2	Pin no.	Function
	1	Self-supervision contact – closed (system alarm)
	2	Self-supervision contact – common
	3	Self-supervision contact – closed (system healthy)
	4	Device charging – closed (device charging)
	5	Device charging – common
	6	Device ready – closed (device is not ready)
	7	Device ready – common
	8	Device ready – closed (device is ready)
	9	Operation blocked – closed (the device is unblocked or de-energized)
	10	Operation blocked – closed (common)
	11	Operation blocked – closed (the device is blocked)
	12	Trip contact
	13	Trip contact
	14	Auxiliary power supply – positive
	15	Auxiliary power supply – negative

Table. 4.2.3 - 11. Descriptions for the fiber connectors.

Fiber connectors	Name	Function
COM 1	COM 1	The primary receiving fiber connector (blue)
COM 2	COM 2	The secondary receiving fiber connector (black)

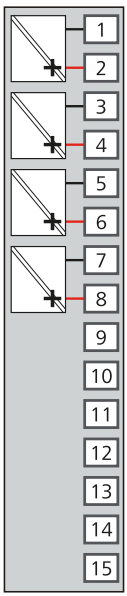
Figure. 4.2.3 - 7. Connection explanation for AQ-1000.

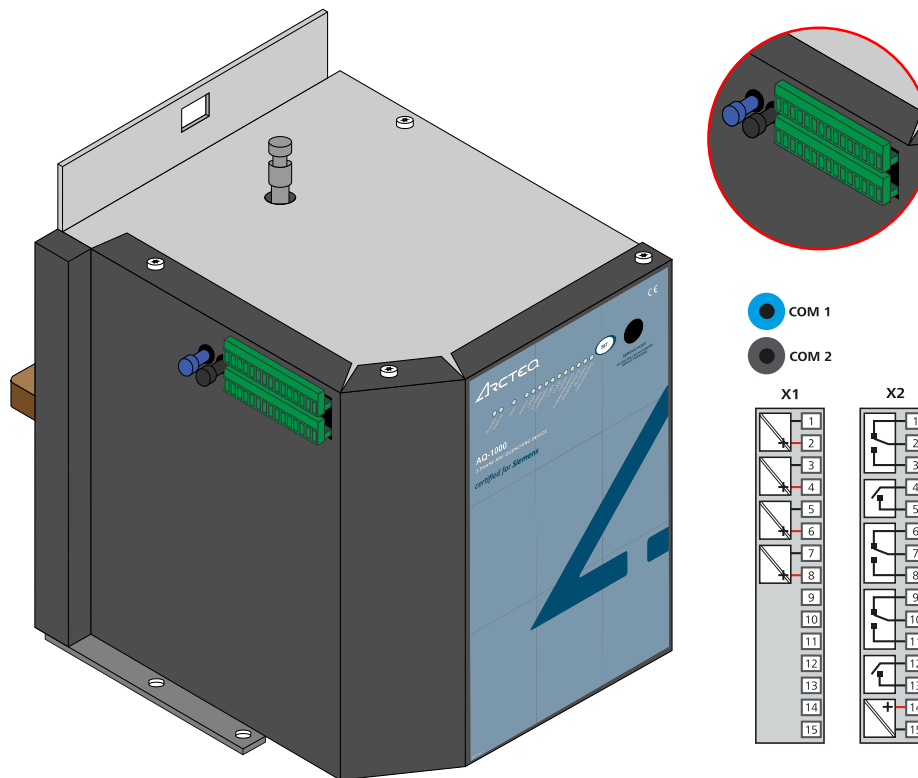

NOTE!



See rated voltages, wire sizing and connector tightening torques in Chapter 11.2.1 of the "Technical data" chapter.

4.2.4 AQ-01 and AQ-02 arc sensors

Table. 4.2.4 - 12. Descriptions for the sensor pins.

Sensor connection	Function
	Ground
	Signal
	Supply

NOTE!



See rated voltages and connector tightening torques in Chapter 11.3 ("Technical data").

5 Configuration

5.1 DIP switches

Functionality such as tripping logic is configured using the DIP switch settings. Tripping may be selected based on arc light only or on both arc light and current thresholds.

NOTE!



Scheme selection is made with DIP switches by calculating the sum of the weight factors.

5.1.1 AQ-101 and AQ-101D

Figure. 5.1.1 - 8. DIP switches of AQ-101 (left) and AQ-101D (right).

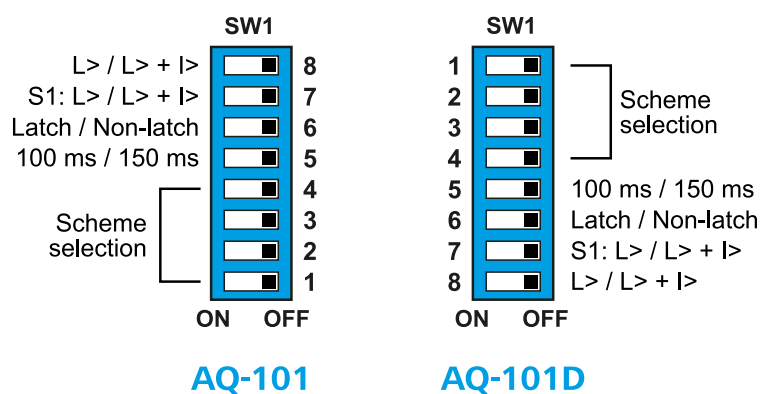

NOTE!



Please note the difference in the DIP switch of AQ-101D: while the numbers and their respective functions are as described below, their positioning is reversed. For example, SW1:1 is at the top instead of the bottom.

Table. 5.1.1 - 13. DIP switch definitions for SW1 of AQ-101 and AQ-101D.

No.	Text	Function at ON	Function at OFF
8	L> / L> + I>	Tripping with light criterion only.	Tripping with light and current criteria.
7	S1: L> / L> + I>	Sensor S1 tripping with light criterion only.	Sensor S1 tripping with light and current criteria.
6	Latch / Non-latch	Output relays latched.	Output relays not latched.
5	100 ms / 150 ms	CBFP operating time is 100 ms.	CBFP operating time is 150 ms.
4	Scheme selection	Weight factor 8	Weight factor 0
3		Weight factor 4	Weight factor 0
2		Weight factor 2	Weight factor 0
1		Weight factor 1	Weight factor 0

5.1.2 AQ-110P

Figure. 5.1.2 - 9. DIP switches of AQ-110P.

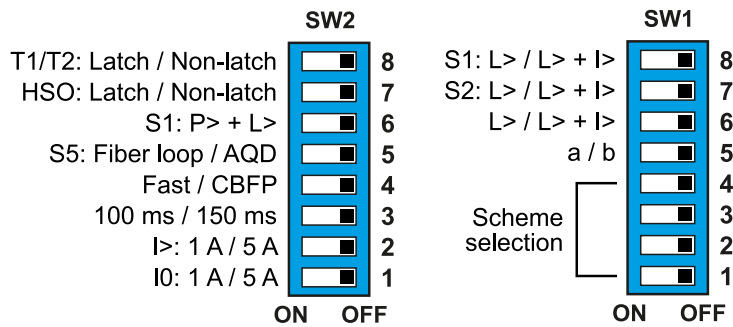

AQ-110P

Table. 5.1.2 - 14. DIP switch definitions for SW1 of AQ-110P.

No.	Text	Function at ON	Function at OFF
8	S1: L> / L> + I>	Sensor S1 tripping with light criterion only.	Sensor S1 tripping with light and current criteria.
7	S2: L> / L> + I>	Sensor S2 tripping with light criterion only.	Sensor S2 tripping with light and current criteria.
6	L> / L> + I>	Tripping of all other sensors with light criterion only.	Tripping of all other sensors with light and current criteria.
5	a / b	Scheme a.	Scheme b.
4	Scheme selection	Weight factor 8	Weight factor 0
3		Weight factor 4	Weight factor 0
2		Weight factor 2	Weight factor 0
1		Weight factor 1	Weight factor 0

Table. 5.1.2 - 15. DIP switch definitions for SW2 of AQ-110P.

No.	Text	Function at ON	Function at OFF
8	T1/T2: Latch / Non-latch	Trip relays T1 and T2 are latched.	Trip relays T1 and T2 are not latched.
7	HSO: Latch / Non-latch	High-speed outputs HSO1 and HSO2 are latched.	High-speed outputs HSO1 and HSO2 are not latched.
6	S1: P> & L>	(N/A)	Sensor S1 is connected with an AQ-01 light sensor or an AQ-02 pressure and light sensor.
5	S5: Fiber loop / AQD	Sensor S5 is connected with a fiber loop sensor.	Sensor S5 is connected with an arc quenching device control (Tx only).
4	Fast / CBFP	Fast mode tripping without circuit breaker failure protection.	Circuit breaker failure protection activated.
3	100 ms / 150 ms	Circuit breaker failure protection delay is set to 100 ms.	Circuit breaker failure protection delay is set to 150 ms.
2	I>: 1A / 5A	Nominal rating of phase current measurement channels is 1 A.	Nominal rating of phase current measurement channels is 5 A.
1	I0>: 1A / 5A	Nominal rating of neutral current measurement channels is 1 A.	Nominal rating of neutral current measurement channels is 5 A.

NOTE!



When CBFP mode is selected (that is, when SW2: 4 is OFF), the trip relay T2 will work as a CBFP relay. If a sensor channel (S2, S3, S4) or an L> input (BI1, BI2) is activated for longer than what has been set as the CBFP delay in SW2: 3 (100 ms or 150 ms), the CBFP function activates the trip relay T2.

NOTE!



Please note that the DIP switch for circuit breaker failure protection's delay (SW2: 3) has no function if the device has been configured to Fast operating mode (that is, when SW2: 4 is ON).

5.2 Potentiometers

Current pick-up setting (set point) is done with potentiometers on the back side of the device. Use a flat screw driver to move the potentiometers to the desired set point. See Chapter 7.2 ("Current measurement") for more information on the accurate setting of the current activation level.

Figure. 5.2 - 10. Setting the current pick-up potentiometers.

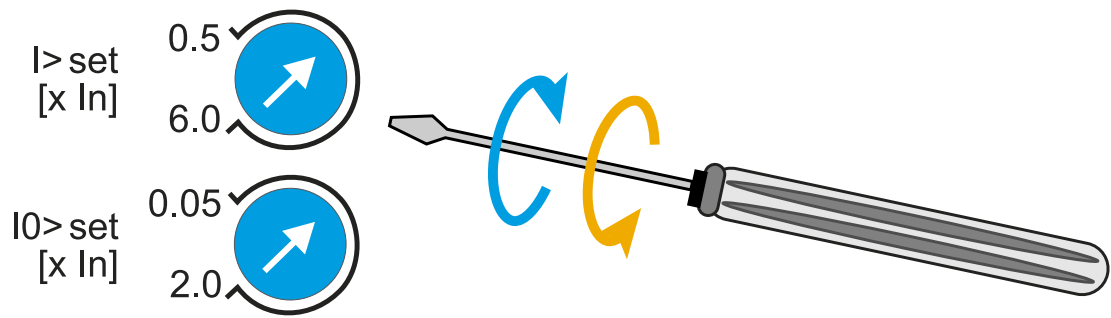

NOTE!



Potentiometers are only in AQ-110P!

5.3 Protection scheme logics

The logic matrices below describe the basic functionality of the following schemes:

- AQ-101 and AQ-101D:
 - SS:0
 - SS:4
- AQ-110P:
 - SS:1a
 - SS:1b
 - SS:2a
 - SS:4a

Please note that the tables do not separate the trip settings between light-only mode and light + current mode. If light + current mode has been selected with the DIP switches, the corresponding light sensor activation requires simultaneous overcurrent injection for tripping to occur. For the CBFP operation, please refer to the relevant DIP switch setting in Chapter 5.1 ("DIP switches").

5.3.1 AQ-101 and AQ-101D

Scheme 0 (SS:0 for AQ-101 and AQ-101D)

Table. 5.3.1 - 16. Logic matrix of Scheme 0 for AQ-101(D).

DIP SWITCH SETTINGS	BI (I>)	SENSOR	TRIP 1	TRIP 2	TRIP 3	TRIP 4	BO1 (L>)
L> only	N/A	Sensor 1	X	X	–	–	X
		Sensor 2	X	X	Latch	–	X
		Sensor 3	X	X	–	Latch	X
		Sensor 4	X	X	Latch	Latch	X
L> + I>	BI1 OFF	Sensor 1	–	–	–	–	X
		Sensor 2	–	–	–	–	X
		Sensor 3	–	–	–	–	X
		Sensor 4	–	–	–	–	X
	BI1 ON	Sensor 1	X	X	–	–	X
		Sensor 2	X	X	Latch	–	X
		Sensor 3	X	X	–	Latch	X
		Sensor 4	X	X	Latch	Latch	X
N/A		None	–	–	–	–	–
N/A	BI2 ON	None	X	X	–	–	–

Scheme 4 (SS:4 for AQ-101 and AQ-101D)

Table. 5.3.1 - 17. Logic matrix of Scheme 4 for AQ-101(D).

DIP SWITCH SETTINGS	BI (I>)	SENSOR	TRIP 1	TRIP 2	TRIP 3	TRIP 4	BO1 (L>)
L> only	N/A	Sensor 1	X	–	–	–	X
		Sensor 2	–	X	Latch	–	X
		Sensor 3	X	X	–	Latch	X
		Sensor 4	X	X	Latch	Latch	X
L> + I>	BI1 OFF	Sensor 1	–	–	–	–	X
		Sensor 2	–	–	–	–	X
		Sensor 3	–	–	–	–	X
		Sensor 4	–	–	–	–	X
	BI1 ON	Sensor 1	X	–	–	–	X
		Sensor 2	–	X	Latch	–	X
		Sensor 3	X	X	–	Latch	X
		Sensor 4	X	X	Latch	Latch	X
N/A		None	–	–	–	–	–
N/A	BI2 ON	None	X	X	–	–	–

5.3.2 AQ-110P

Scheme 1a and 1b (SS:1a, SS:1b)

Table. 5.3.2 - 18. Logic matrix of Scheme 1a and Scheme 1b for AQ-110P.

DIP SWITCH SETTINGS	OVER-CURRENT SIGNAL (I>)	SENSOR	TRIP 1	TRIP 2	TRIP 3	TRIP 4	BO1 (L>)	HSO1 (I>)	HSO2 (MT)	S5/ AQD
L> only	Current OFF	Sensor 1	X	X	–	–	X	–	X	X
		Sensor 2	X	CBFP	Latch	–	X	–	X	X
		Sensor 3	X	CBFP	–	Latch	X	–	X	X
		Sensor 4	X	CBFP	Latch	Latch	X	–	X	X
		BI2 (L> 101)	X	CBFP	–	–	X	–	X	X
		BI1 (L> 110)	X	CBFP	–	–	–	–	X	X
	Current ON	Sensor 1	X	X	–	–	X	X	X	X
		Sensor 2	X	CBFP	Latch	–	X	X	X	X
		Sensor 3	X	CBFP	–	Latch	X	X	X	X
		Sensor 4	X	CBFP	Latch	Latch	X	X	X	X
		BI2 (L> 101)	X	CBFP	–	–	X	X	X	X
		BI1 (L> 110)	X	CBFP	–	–	–	X	X	X
L> + I>	Current OFF	Sensor 1	–	–	–	–	X	–	–	–
		Sensor 2	–	–	–	–	X	–	–	–
		Sensor 3	–	–	–	–	X	–	–	–
		Sensor 4	–	–	–	–	X	–	–	–
		BI2 (L> 101)	–	–	–	–	X	–	–	–
		BI1 (L> 110)	–	–	–	–	–	–	–	–
	Current ON	Sensor 1	X	X	–	–	X	X	X	X
		Sensor 2	X	CBFP	Latch	–	X	X	X	X
		Sensor 3	X	CBFP	–	Latch	X	X	X	X
		Sensor 4	X	CBFP	Latch	Latch	X	X	X	X
		BI2 (L> 101)	X	CBFP	–	–	X	X	X	X
		BI1 (L> 110)	X	CBFP	–	–	–	X	X	X
N/A	Current ON	None	–	–	–	–	–	X	–	–

NOTE!



The overcurrent signal from HSO1 can go to AQ-101 and to AQ-110P.

Scheme 2a (SS:2a)

Table. 5.3.2 - 19. Logic matrix of Scheme 2a for AQ-110P.

DIP SWITCH SETTINGS	OVER-CURRENT SIGNAL (I>)	SENSOR	TRIP 1	TRIP 2	TRIP 3	TRIP 4	BO1 (I>)	HSO1 (I>)	HSO2 (MT)	S5/AQD
L> only	Both BI1 and current OFF	Sensor 1	X	X	-	-	-	-	X	-
		Sensor 2	X	X	Latch	-	-	-	X	-
		Sensor 3	X	X	-	Latch	-	-	X	-
		Sensor 4	X	X	Latch	Latch	-	-	X	-
		BI2 (L> ext)	X	X	-	-	-	-	X	-
	BI1 ON	Sensor 1	X	X	-	-	-	X	X	X
		Sensor 2	X	X	Latch	-	-	X	X	X
		Sensor 3	X	X	-	Latch	-	X	X	X
		Sensor 4	X	X	Latch	Latch	-	X	X	X
		BI2 (L> ext)	X	X	-	-	-	X	X	X
	Current ON	Sensor 1	X	X	-	-	X	X	X	X
		Sensor 2	X	X	Latch	-	X	X	X	X
		Sensor 3	X	X	-	Latch	X	X	X	X
		Sensor 4	X	X	Latch	Latch	X	X	X	X
		BI2 (L> ext)	X	X	-	-	X	X	X	X
L> + I>	Both BI1 and current OFF	Sensor 1	-	-	-	-	-	-	-	-
		Sensor 2	-	-	-	-	-	-	-	-
		Sensor 3	-	-	-	-	-	-	-	-
		Sensor 4	-	-	-	-	-	-	-	-
		BI2 (L> ext)	-	-	-	-	-	-	-	-
	BI1 ON	Sensor 1	X	X	-	-	-	X	X	X
		Sensor 2	X	X	Latch	-	-	X	X	X
		Sensor 3	X	X	-	Latch	-	X	X	X
		Sensor 4	X	X	Latch	Latch	-	X	X	X
		BI2 (L> ext)	X	X	-	-	-	X	X	X
	Current ON	Sensor 1	X	X	-	-	X	X	X	X
		Sensor 2	X	X	Latch	-	X	X	X	X
		Sensor 3	X	X	-	Latch	X	X	X	X
		Sensor 4	X	X	Latch	Latch	X	X	X	X
		BI2 (L> ext)	X	X	-	-	X	X	X	X
N/A	BI1	None	-	-	-	-	X	-	-	
N/A	Current ON	None	-	-	-	-	X	-	-	

NOTE!



The overcurrent signal from HSO1 can go to AQ-101 and to AQ-110P. AQD is always tripped by the criterion "L> + I>" (light + current), even when the DIP switch mode "L>" (light-only) has been selected.

Scheme 4a (SS:4a)

Table. 5.3.2 - 20. Logic matrix of Scheme 4a for AQ-110P.

DIP SWITCH SETTINGS	OVERCURRENT SIGNAL (I>)	SENSOR	TRIP 1	TRIP 2	TRIP 3	TRIP 4	BO1 (L>)	HSO1 (I>)	HSO2 (MT)	S5/ AQD
L> only	Both BI2 and current OFF	Sensor 1	X	X	–	–	X	–	X	–
		Sensor 2	X	X	Latch	–	X	–	X	–
		Sensor 3	X	X	–	Latch	X	–	X	–
		Sensor 4	X	X	Latch	Latch	X	–	X	–
	BI2 ON	Sensor 1	X	X	–	–	X	–	X	X
		Sensor 2	X	X	Latch	–	X	–	X	X
		Sensor 3	X	X	–	Latch	X	–	X	X
		Sensor 4	X	X	Latch	Latch	X	–	X	X
	Current ON	Sensor 1	X	X	–	–	X	X	X	X
		Sensor 2	X	X	Latch	–	X	X	X	X
		Sensor 3	X	X	–	Latch	X	X	X	X
		Sensor 4	X	X	Latch	Latch	X	X	X	X
L> + I>	Both BI1 and current OFF	Sensor 1	–	–	–	–	X	–	–	–
		Sensor 2	–	–	–	–	X	–	–	–
		Sensor 3	–	–	–	–	X	–	–	–
		Sensor 4	–	–	–	–	X	–	–	–
	BI1 ON	Sensor 1	X	X	–	–	X	–	X	X
		Sensor 2	X	X	Latch	–	X	–	X	X
		Sensor 3	X	X	–	Latch	X	–	X	X
		Sensor 4	X	X	Latch	Latch	X	–	X	X
	Current ON	Sensor 1	X	X	–	–	X	X	X	X
		Sensor 2	X	X	Latch	–	X	X	X	X
		Sensor 3	X	X	–	Latch	X	X	X	X
		Sensor 4	X	X	Latch	Latch	X	X	X	X
N/A	BI1 (MT)	None	X	X	–	–	–	–	X	X
N/A	Current ON	None	–	–	–	–	–	X	–	–
N/A	BI2	None	–	–	–	–	–	–	–	–

NOTE!



Scheme 4a is otherwise the same as Scheme 2a, but BO1 is "L>" instead of "I>".
The overcurrent signal from HSO1 can go to AQ-101 and to AQ-110P.
AQD is always tripped by the criterion "L> + I>" (light and current), even when the DIP switch mode "L>" (light only) has been selected.

5.3.3 I/O description

Table. 5.3.3 - 21. I/O descriptions.

AQ-110P	AQ-101, AQ-101D	I/O description
IL1/IL2/IL3/I0		The current inputs for phases IL1, IL2, IL3 and E/F I0, measuring the current for incomer.
BI1		The function of the BI1 binary input depends on the selected scheme. It also acts as an external overcurrent signal or as a master trip signal.
BI2		Receives a light signal (L>) from the connected AQ-101(D) unit. In Schemes 1a and 2a, BI2 counts the number of connected AQ-101(D) units while supervising each BO1 connection from AQ-101(D) units. In Scheme 1b, BI2 excludes the counting function and triggers the self-supervision alarm (the SF relay) when the connections to all connected AQ-101(D) units are lost.
S1		Usually, S1 is used to detect arc flash light for an incomer cable compartment, but it can also be used to detect arc flash light for an outgoing feeder compartment or some other compartment.
S2/S3/S4		Detects arc flash light... a) ...usually for an incomer switching device and a busbar compartment, or b) ...usually for a feeder busbar compartment, a switching device, and a cable compartment.
HSO1		Sends an overcurrent signal (I>) to all connected AQ-101(D) units. In normal operations, HSO1 is used to synchronize all connected AQ-101(D) units.
HSO2		Send the master trip signal (MT) to all connected AQ-101(D) units. When HSO2 activates, the connected AQ-101(D) units activate the T1 and T2 trip relays.
BO1		Depending on the scheme selection, sends a sensor channel (S1, S2, S3, S4), a light signal (L>) of the BI2 binary input, and/or an overcurrent signal (I>) to the connected AQ-110P unit.
T1		The trip relay for an incomer circuit breaker.
T2		The trip relay for an incomer upstream circuit breaker.
T3/T4		The trip relays used mainly for fault location identification.
	BI1	Receives an overcurrent signal (I>) from the connected AQ-110P unit.
	BI2	Receives the master trip signal (MT) from the connected AQ-110P unit.
	S1/S2/S3/S4	Detects arc flash light for a feeder busbar compartment, a switching device compartment, and a cable compartment.
	BO1	Sends a sensor channel (S1, S2, S3, S4) to the connected AQ-110P unit. In normal operations, BO1 is used to send a feedback pulse to the connected AQ-110P unit.
	T1/T2	The trip relay for a feeder circuit breaker or a bussectionalizer circuit breaker (if available).
	T3/T4	The trip relays used mainly for fault location identification.

6 Operation

6.1 Operation of an arc flash protection relay

6.1.1 LED indicators

All the devices contain LED indicators for the unit's operating states. The following figures present the front panels with these LEDs, and the following tables explain the states for each of the LEDs.

AQ-101 and AQ-101D

Figure. 6.1.1 - 11. The front panels of AQ-101 (left), and AQ-101D (right).

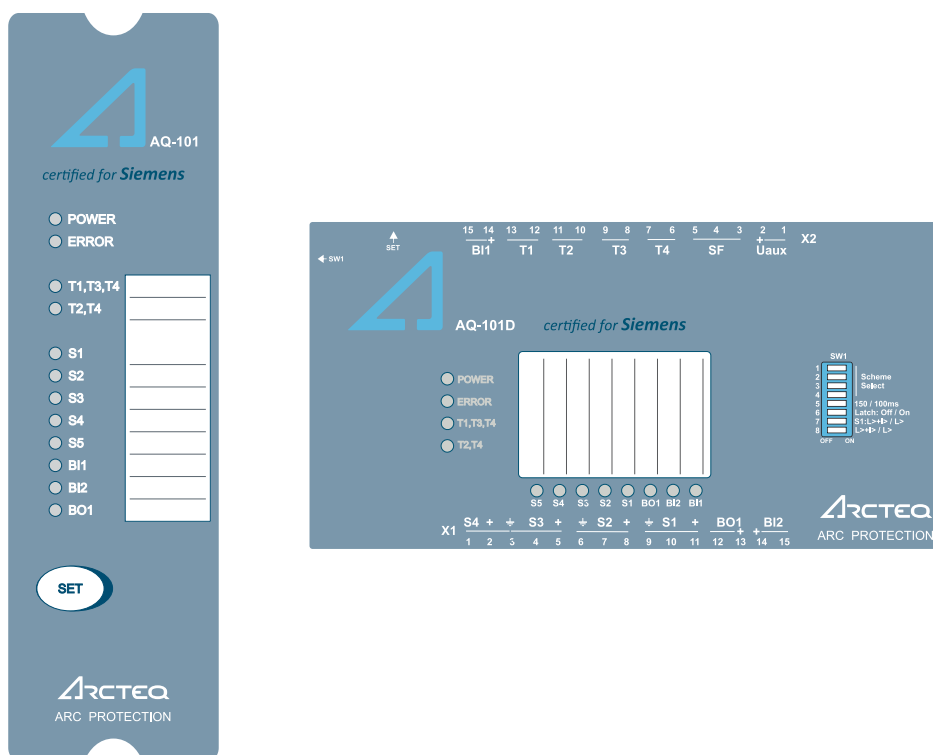

Table. 6.1.1 - 22. LED indication definitions for AQ-101 and AQ-101D.

LED name	LED color	OFF	Steady ON	Blinking
Arcteq logo	Blue	The auxiliary supply is disconnected.	The auxiliary power is connected.	(N/A)
Power	Blue	The auxiliary supply is disconnected.	The auxiliary power is connected.	(N/A)
Error	Red	The system is healthy.	There is a system failure.	There is a configuration mismatch; protection is partly operational.
T1, T3, T4	Red	Normal status.	The trip relays T1, T3, T4 have activated.	(N/A)
T2, T4	Red	Normal status.	The trip relays T2, T4 have activated.	(N/A)
S1	Amber	Normal status.	The corresponding sensor channel has activated.	The corresponding sensor channel has a loose connection, <u>or</u> the system set-up has not been performed.
S2 / S3 / S4 / S5	Amber	Normal status.	The corresponding sensor channel has activated.	The corresponding sensor channel has a loose connection, <u>or</u> the system set-up has not been performed.
BI1 / BI2	Amber	Normal status.	The corresponding binary input has activated.	The corresponding binary input has lost its connection.
BO1	Amber	Normal status.	The binary output has activated.	(N/A)

AQ-110P

Figure. 6.1.1 - 12. The front panel of AQ-110P.

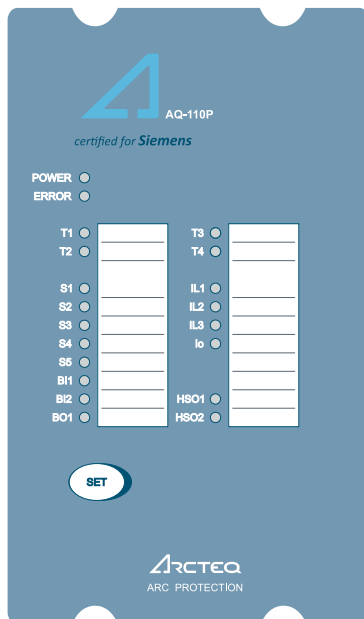

Table. 6.1.1 - 23. LED indication definitions for AQ-110P.

LED name	LED color	OFF	Steady ON	Blinking
Arcteq logo	Blue	The auxiliary supply is disconnected.	The auxiliary power is connected.	(N/A)
Power	Blue	The auxiliary supply is disconnected.	The auxiliary power is connected.	(N/A)
Error	Red	The system is healthy.	There is a system failure.	There is a configuration mismatch; protection is partly operational.
T1 / T2 / T3 / T4	Red	Normal status.	The corresponding trip relay has activated.	(N/A)
S1	Amber	Normal status.	The corresponding sensor channel has activated.	The corresponding sensor channel has a loose connection, or the system set-up has not been performed.
S2 / S3 / S4	Amber	Normal status.	The corresponding sensor channel has activated.	The corresponding sensor channel has a loose connection, or the system set-up has not been performed.
S5	Amber	Normal status.	The corresponding sensor channel has activated, or the arc quenching device has activated.	The corresponding sensor channel has a loose connection, or the system set-up has not been performed.
BI1 / BI2	Amber	Normal status.	The corresponding binary input has activated.	The corresponding binary input has lost its connection.
BO1	Amber	Normal status.	The binary output has activated.	(N/A)
IL1 / IL2 / IL3	Amber	Normal status, the measured current is below the set point.	The corresponding current channel has exceeded the set point; the overcurrent stage has activated.	Unbalance alarm; or the corresponding channel's CT connection is open; or the corresponding channel has been active for longer than 10 s.
I0	Amber	Normal status, the measured current is below the set point.	The residual current has exceeded the set point; the overcurrent stage has activated.	(N/A)
HSO1 / HSO2	Red	Normal status.	The corresponding HSO channel has activated.	(N/A)

6.1.2 Text pocket

All devices contain a text pocket for entering sensor-specific information. The text pocket can be slid out, and text can be added either by writing on the text label sheet or by replacing it with a printed label.

Figure. 6.1.2 - 13. Using the text pocket.

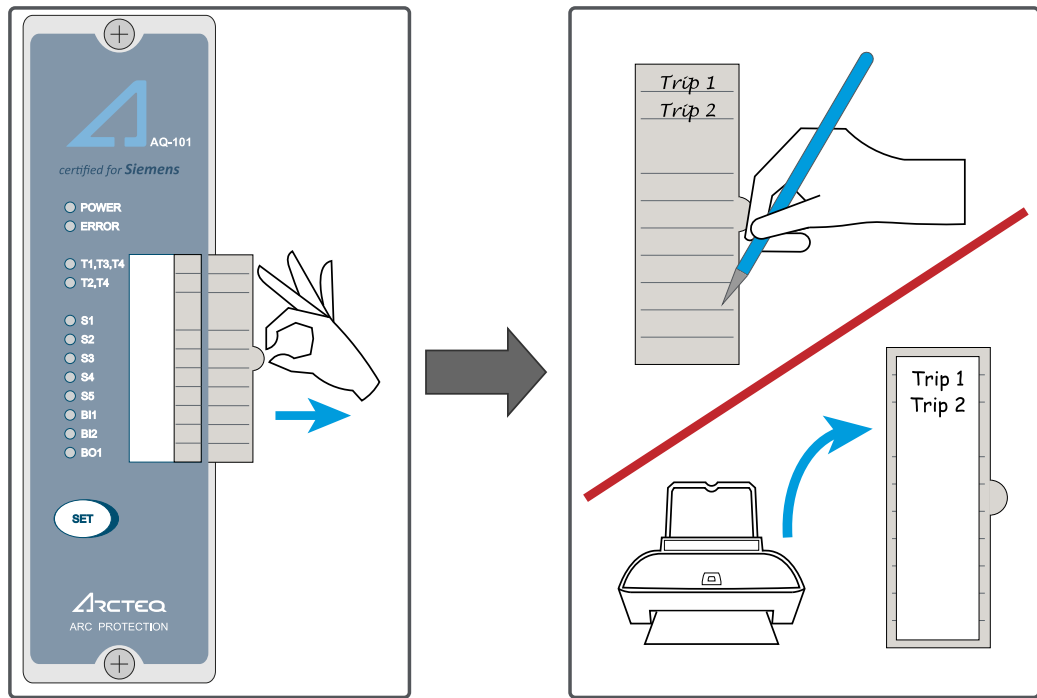

6.1.3 SET button

The SET push button is used for installing the system, for checking the number of connected sensors and units, for resetting the device after a trip event, and for clearing alarm signals. AQ-101 and AQ-110P have a SET button in the front panel, whereas AQ-101D has it on the top of the unit.

Figure. 6.1.3 - 14. The SET button in the front panel.

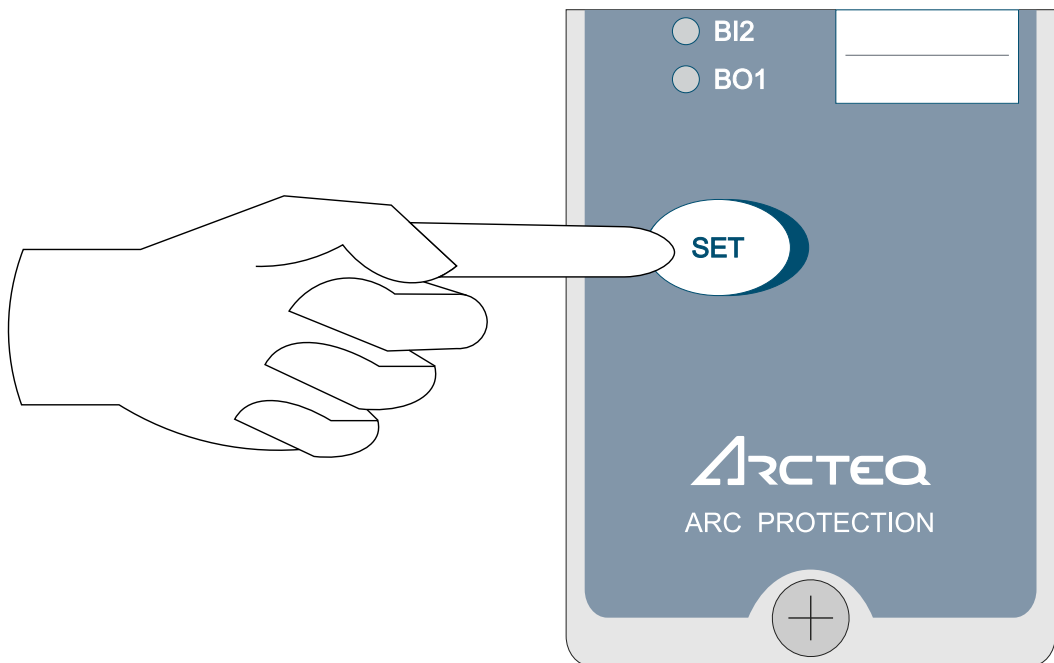

Table. 6.1.3 - 24. Functions of the SET button.

Function	Instruction	Indications
Installing a new system configuration (when a binary input has been added, or the number of connected sensors has changed)	Press the SET button for three (3) seconds.	The LEDs of all connected inputs are steadily lit during installation.
Install a new system configuration (when a binary input has been removed, or the number of connected sensors has changed)	Switch any of the DIP switches back and forth once, and then press the SET button for three (3) seconds.	The LEDs of all connected inputs are steadily lit during installation.
Clear the alarm signals	Press the SET button once.	The blinking LED indicators turn off.
Check the number of connected sensors and the number of unit connections (binary inputs)	Press the SET button three (3) times within two (2) seconds.	The LEDs of the corresponding connected inputs blink to show the number of connected units and sensors.
Reset the device after a trip, or after a sensor or binary input activation	Press the SET button once.	The LEDs of the corresponding connected inputs blink to show the number of connected units and sensors.

NOTE!



These instructions do not apply to AQ-1000; please see Chapter 6.2.4 ("SET button") for its functions!

6.2 Operation of an arc quenching device

NOTE!



AQ-1000 does not contain any user-settable or application-specific parameters or values! For the operation of the MV arc quenching device, please refer to the respective instruction manuals from Siemens!

6.2.1 LED indicators

Figure. 6.2.1 - 15. The front panel of AQ-1000 (top half).



Table. 6.2.1 - 25. LED indication definitions for AQ-1000.

LED name	LED color	OFF	Steady ON	Blinking
Arcteq logo	Blue	The auxiliary supply is disconnected.	The auxiliary power supply is connected.	(N/A)
Power	Blue	The auxiliary supply is disconnected.	The auxiliary power supply is connected.	An internal voltage error has occurred.
Error	Red	The system is healthy.	The system is unhealthy.	(N/A)
Trip	Red	The device has not tripped.	The device has tripped.	(N/A)
Ready	Green	The device is not ready to trip.	The device is ready to trip.	(N/A)
Open	Green	The arc quenching contacts are not open.	The arc quenching contacts are open.	The arc quenching contacts are in an erroneous position, not fully open or fully closed.
Closed	Red	The arc quenching contacts are not closed.	The arc quenching contacts are closed.	
Charging	Amber	The device is not charging.	The device is charging its energy storage.	There is a charging error.
COM1	Green	(N/A)	The fiber connection is healthy.	The fiber connection is lost.
COM2	Green			
Clear	Green	The "Clear" input is inactive.	The "Clear" input is active.	(N/A)
Commissioning	Amber	The commissioning mode is off.	The device is in Commissioning mode.	(N/A)
Maintenance	Amber	No maintenance needed.	Maintenance is needed; contact the manufacturer.	Maintenance is needed; contact the manufacturer.
Blocked	Red	The device is unblocked.	The blocking function is activate.	(N/A)
Discharging	Red	(When the device is OFF) The energy storage has been discharged.	The device is discharging the energy storage.	(N/A)
		(When the device is ON) The energy storage is not being discharged.		

NOTE!



When the "Error" LED is active, please refer to the table above for troubleshooting. All self-resolved errors are indicated by a blinking LED while the "Error" LED is off.

6.2.2 Operating modes

Table. 6.2.2 - 26. Arc quenching device's operating modes and their definitions.

Mode	Definition
Charging	In Charging mode the device charges its energy storage with enough energy to move the contacts to the "Closed" position. During normal operation, charging occurs several times in an hour as the charged energy level is constantly monitored and adjusted. When the device is charging, the "Charging" LED on the device's front panel is on.
Ready	In Ready mode the device's energy storage is charged to a sufficient energy level and the device is ready to operate.
Trip	In Trip mode the device has operated and its energy storage is empty. The "Trip" and "Closed" LED indicators are on.
Blocked	Blocked mode occurs when the binary input BI4 is energized. During blocking the movement of the arc quenching contacts is prevented.
Discharging	Discharging mode occurs when the device's auxiliary power is disconnected. In this mode the energy storage is safely discharged. The "Discharging" LED stays on until the device has reached a safe voltage level. For discharging time specifications see Chapter 11.2.2 ("Technical data" → "Device ratings").

Figure. 6.2.2 - 16. Operating mode "Ready".



Figure. 6.2.2 - 17. Operating mode "Trip".



6.2.3 Binary input functions

Table. 6.2.3 - 27. Binary input functions of AQ-1000.

Binary input	LED name	Function
Binary input 1	Clear	Clears and resets the LED indications after an error or a trip event.
Binary input 2	Commissioning	When the device is in Commissioning mode, it can be tripped any number of times.
Binary input 3	(N/A)	Not in use (reserved for future use).
Binary input 4	Blocked	Blocks the activation of the trip contact during commissioning tests or during any other circumstances where actual tripping must be prevented.

6.2.4 SET button

AQ-1000 contains contains a SET button in the front panel of the device. It is used for resetting the LED indicators and for clearing the alarm signals.

Figure. 6.2.4 - 18. The SET button.

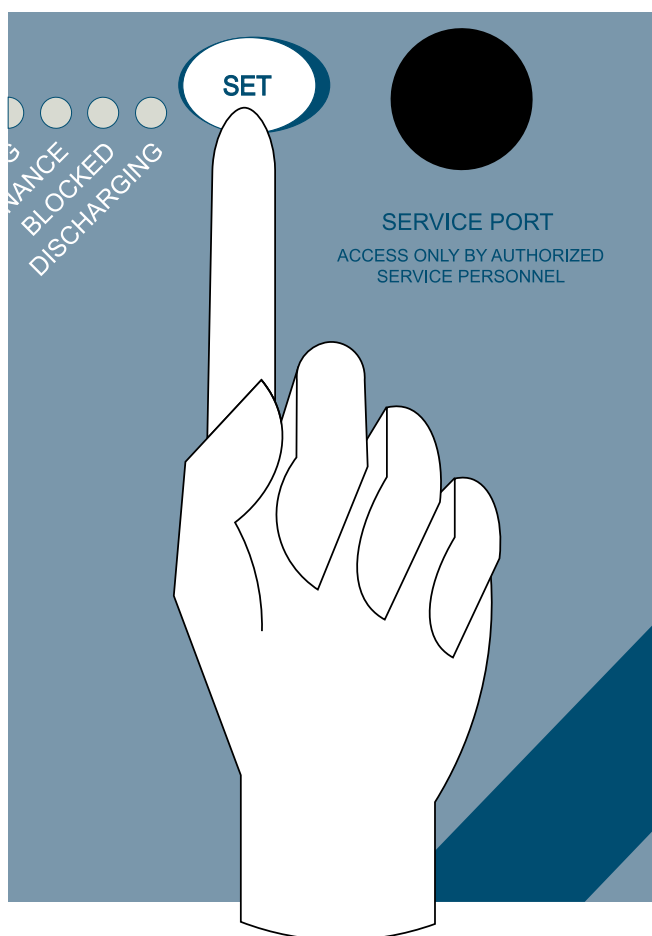

NOTE!



After a trip has occurred, the arc quenching contacts must be reset by pressing the SET button or by activating an external clearing with an energized BI1.

6.2.5 Resetting the quencher after a trip

When a trip has occurred, the arc quenching contacts have to be reset to the open position by using the reset handle provided with the arc quenching device:

1. Put the handle firmly in its slot on the top of the device.
2. Push the handle upward to move the shaft towards the open position.
3. Push the handle further upwards to move the shaft to the completely open position.
4. Press the SET button.

The device indicates the open position with the "Open" LED indicator. A typical charging time of the energy storage from empty to full is less than ten (10) minutes.

Figure. 6.2.5 - 19. Resetting the arc quenching contacts.

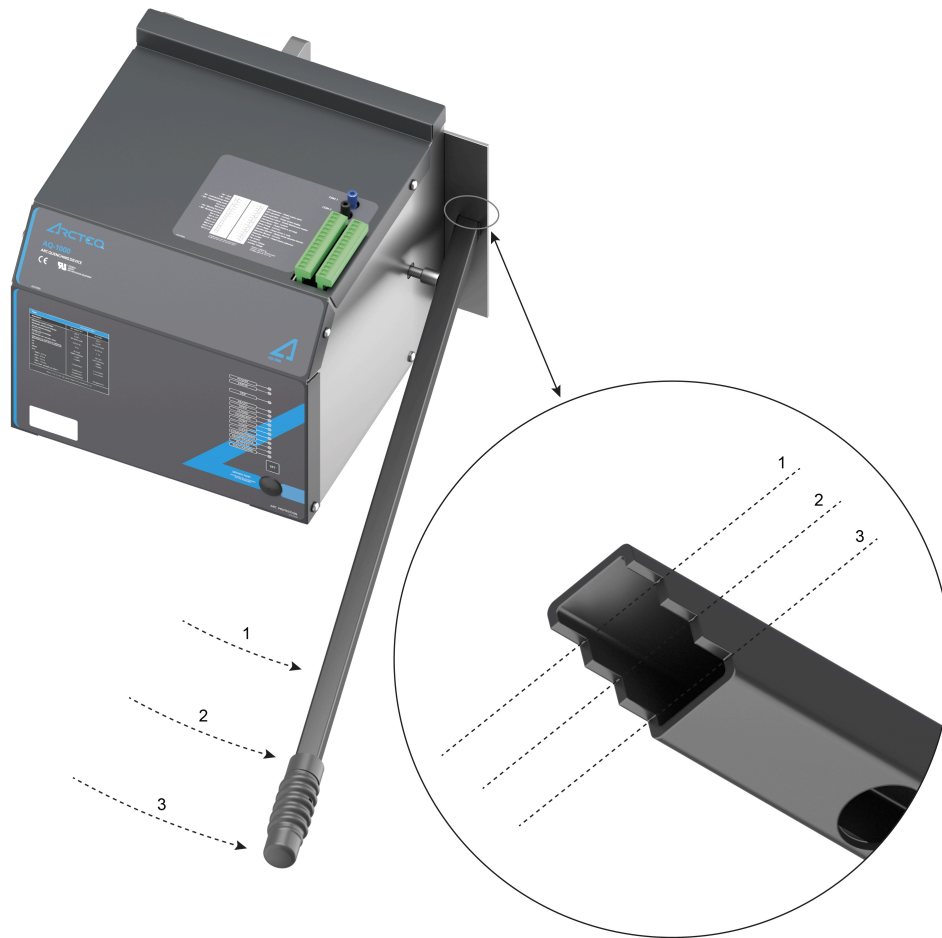

WARNING!



Remember to remove the handle after resetting the contacts! If the handle is not removed, it may fly off from its slot when the next rip event occurs, causing harm to personnel or damage to equipment.

WARNING!



Never attach the handle to the device when the device's shaft is in the open position.

6.3 Sensor operation

The sensor connectors are located at both ends of the sensor under the grey covering. A maximum of three (3) sensor can be connected in series. After connecting a sensor to a relay, the red "Error" LED turns on and the appropriate sensor channel LED starts to blink. Press and hold the SET button on a relay's front panel for three (3) seconds to run the system auto-configuration setting.

For additional information on configuration-related technical instructions please refer to Chapter 6.1.3 ("SET button").

Figure. 6.3 - 20. Configuring an arc flash sensor.

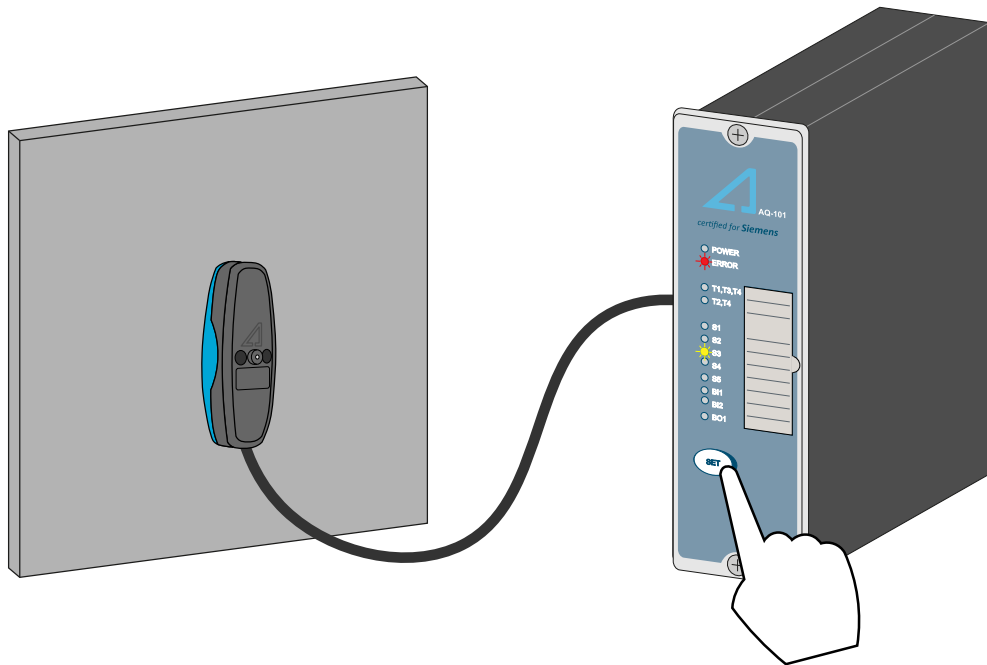

7 Commissioning of arc flash relays

7.1 System installation

When all the connections are done, the system is commissioned by installing the devices one by one. Depending on the Installation is done by pressing the SET button according to the instruction in Chapter 6.1.3 ("SET button").

7.2 Current measurement

NOTE!

 Current measurement is applicable only to AQ-110P!

Current measurement channels should be adjusted to the pick-up setting value according to the following procedure.

Figure. 7.2 - 21. Procedure for current measurement commissioning.

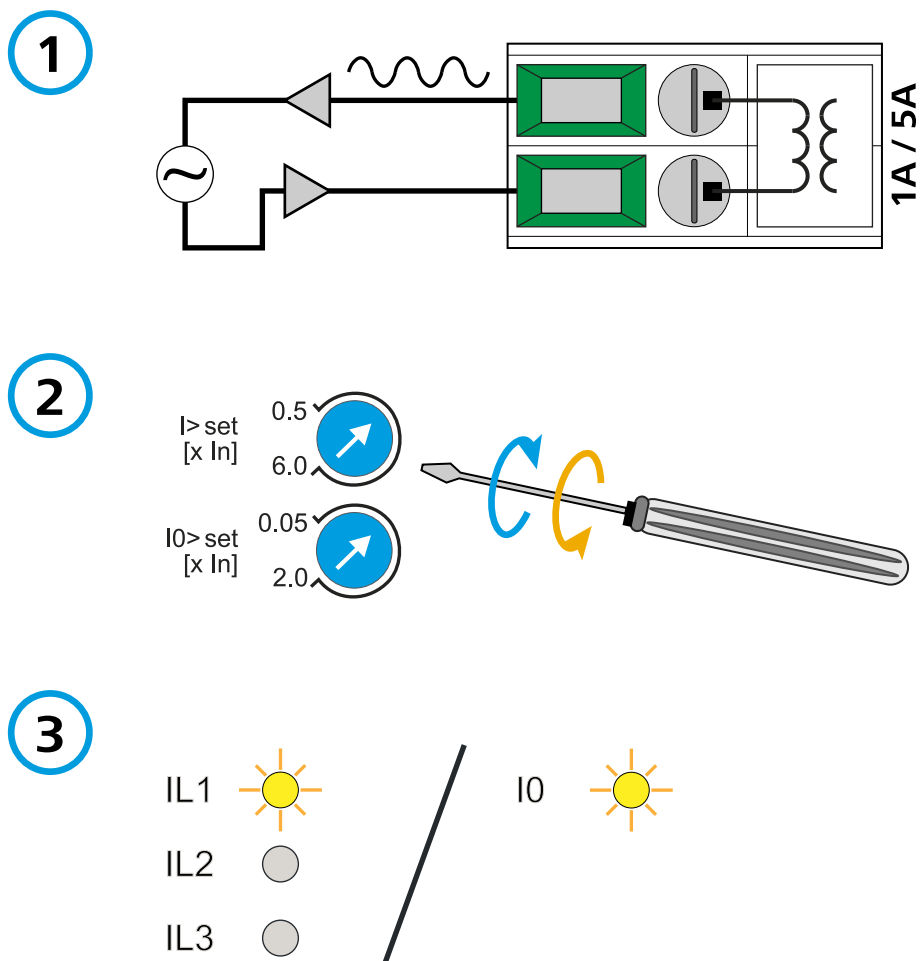

1. Inject the desired value of the current pick-up level separately to IL1 and to I0.
2. Start from the maximum setting and slowly adjust the potentiometer by turning it counterclockwise with a screwdriver.
3. The LED of the corresponding current measurement channel is lit steadily when the activation with injected current has occurred.

NOTE!



The measurement channels IL1, IL2 and IL3 have a common adjustment potentiometer "I> set". It is therefore **not** necessary to commission the three current measurement channels separately. Alternatively, the current measurement channels IL1, IL2 and IL3 can be injected with the same current in serial connection. After a successful commissioning the device has to be installed again according to the instructions in Chapter 6.1.3 ("SET button").

7.3 Light channel activation

Light channels are commissioned by applying a strong light to the light sensor's detector area. For arc light simulation use a superior camera flash. For testing non-latched signals and the CBFP function use a strong flashlight. Make sure that the camera flash or flashlight has a fully charged battery when testing.

The same procedure applies to fiber sensors as well.

1. Apply light to the light sensor's detection area.
2. The LED of the corresponding light sensor channel lights steadily when the sensor has detected the light.

Figure. 7.3 - 22. Light channel activation.

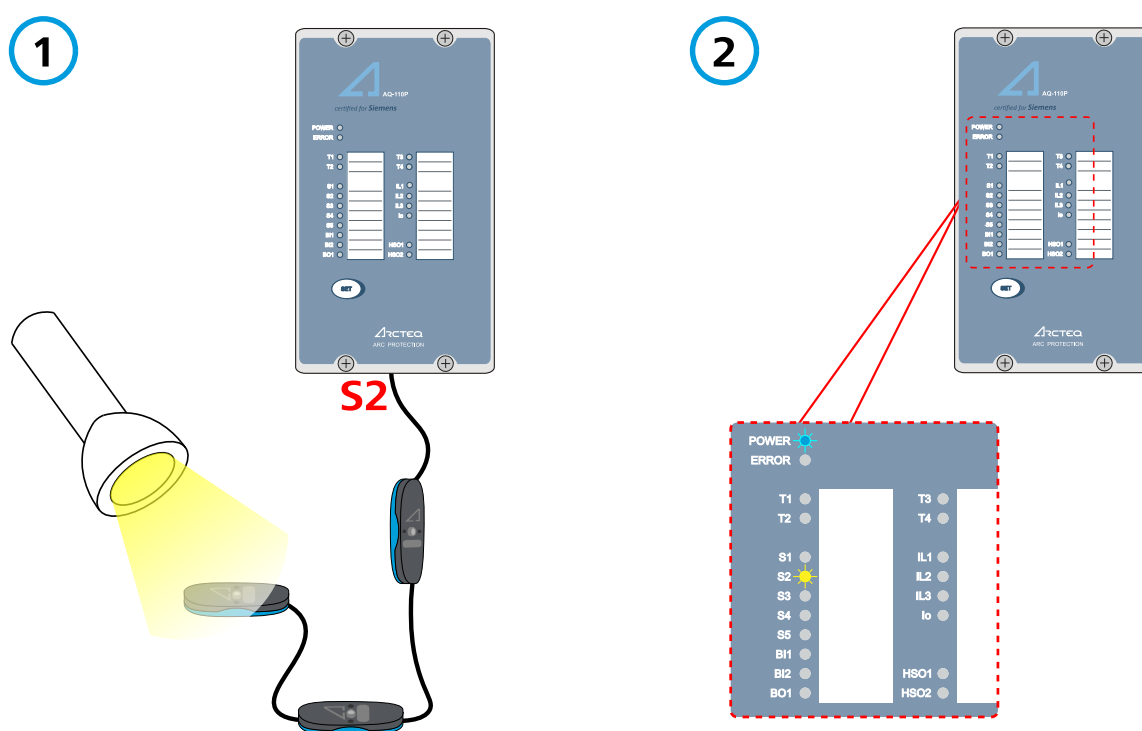

NOTE!



Use a strong, non-LED light source (such as a xenon or a halogen lamp) for light channel activation. There are three sensitivity level options for light sensors (please refer to Chapter 13, "Order codes"). The less sensitive the sensor is, the stronger the light source must be. If the light activation lasts longer than three (3) seconds, the device initiates a self-supervision error. For more information please refer to Chapters 10 ("Troubleshooting") and 6.1.1 ("LED indicators").

7.4 Activation of outputs (tripping)

The activations of output relays, of electrical binary outputs and of high-speed outputs are dependent on on the application scheme of the device. Please refer to Chapter 5.3 ("Protection scheme logics") and to Chapter 6.1.1 ("LED indicators").

NOTE!



The activation mode of the outputs (light-only or light + current) is selected with the DIP switches; see Chapter 5.1 ("DIP switches").

7.5 Testing

The functionality of sensors and sensor channels can be tested in light-oly mode, or in light and current mode. You can also test the CBFP function.

Please see the AQ 100 series unit manuals (in English) for more detailed instructions on testing.

8 Commissioning of AQ-1000

Commissioning the AQ-1000 arc quenching device requires an entire arc protection system to be installed and configured first (see Chapter 9, "Low-voltage arc protection applications").

When commissioning, Blocked mode operation can be used to verify the correct signal transmission to the AQ-1000 device. When the binary input BI4 is energized and the "Blocked" LED indicator is on, the commissioning trip can be performed without the device actually operating.

It is also recommended to perform commissioning trip(s) to verify that the arc quenching contacts move correctly. When BI4 has been de-energized, the device returns back to the Ready operating mode.

WARNING!



Remember to remove the handle after resetting the contacts! If the handle is not removed, it may fly off from its slot when the next trip event occurs, causing harm to personnel or damage to equipment.

WARNING!



Before performing a commissioning trip to confirm the movement of arc quenching contacts, verify that there is no voltage on busbars and that all feeding circuits are disconnected and locked!

9 Arc protection applications

9.1 Low-voltage arc protection applications

9.1.1 One incomer

Figure. 9.1.1 - 23. Application with one incomer.

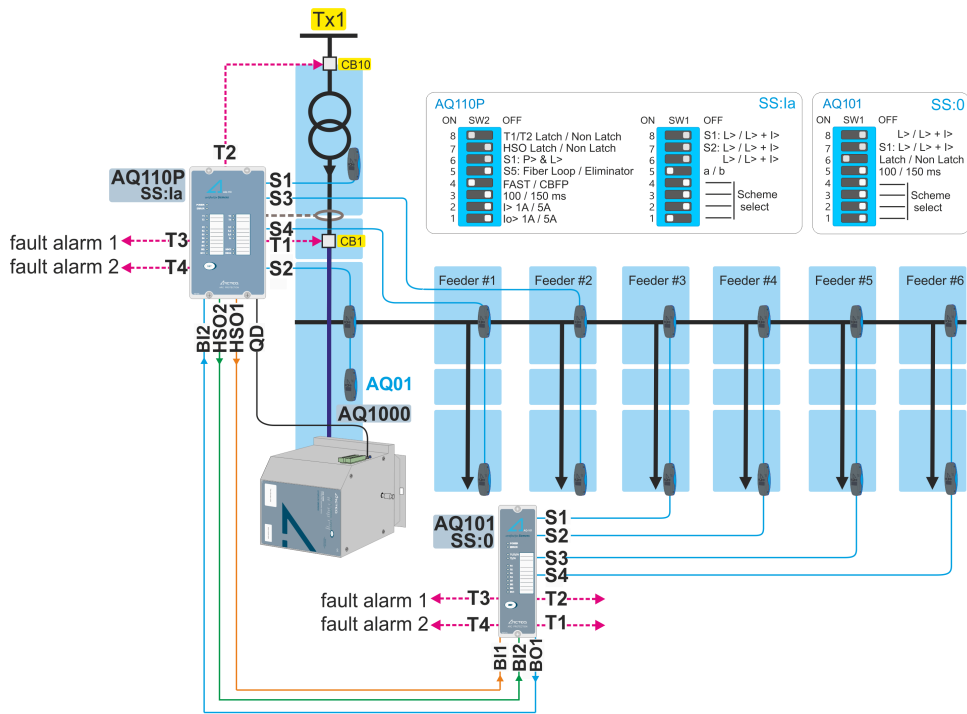

9.1.2 Two incomers without a tie breaker

Figure. 9.1.2 - 24. Application with two incomers and no tie breaker.

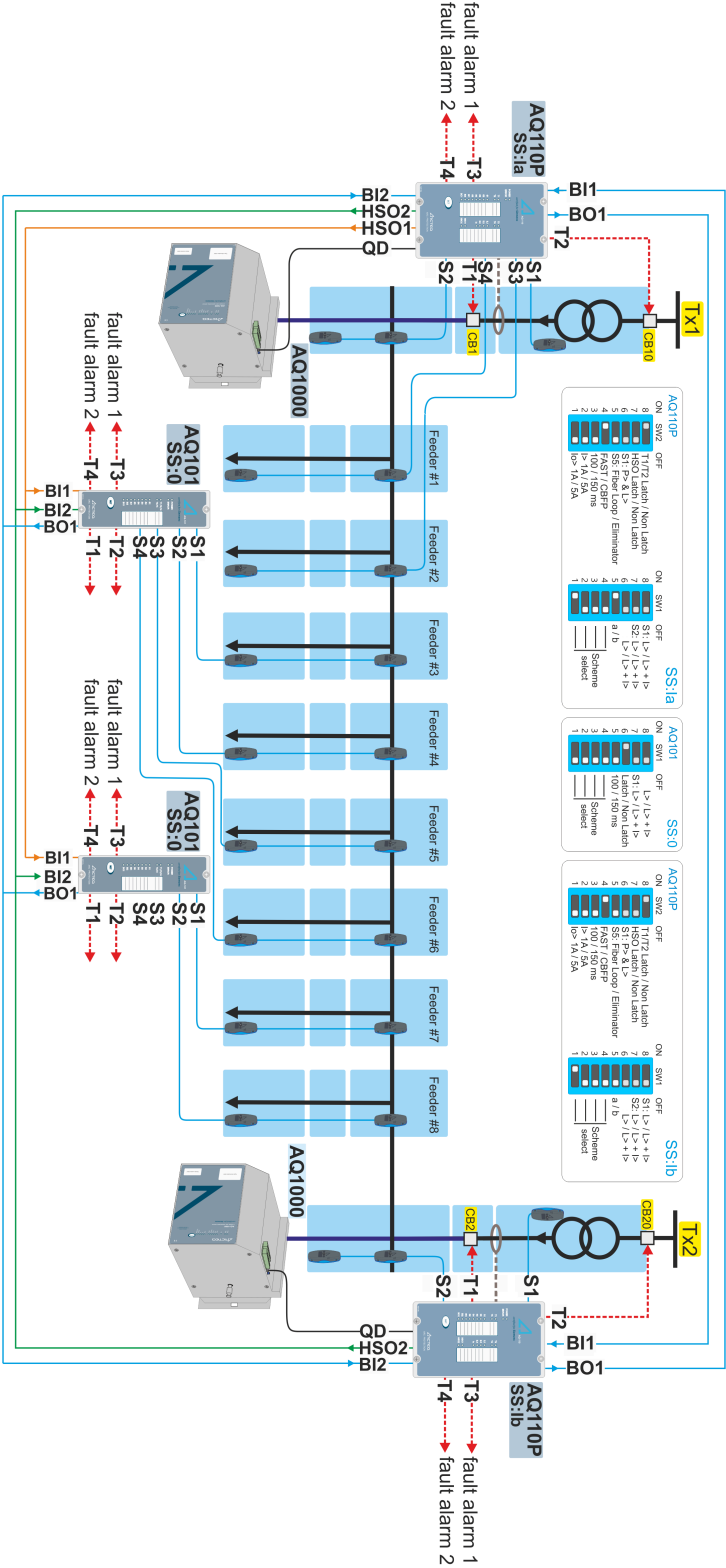

9.1.3 Two incomers with a tie breaker (shared L>)

NOTE!

The two AQ-110P units in this application share the light signal (L>) between them.

Figure. 9.1.3 - 25. Application with two incomers and a tie breaker.

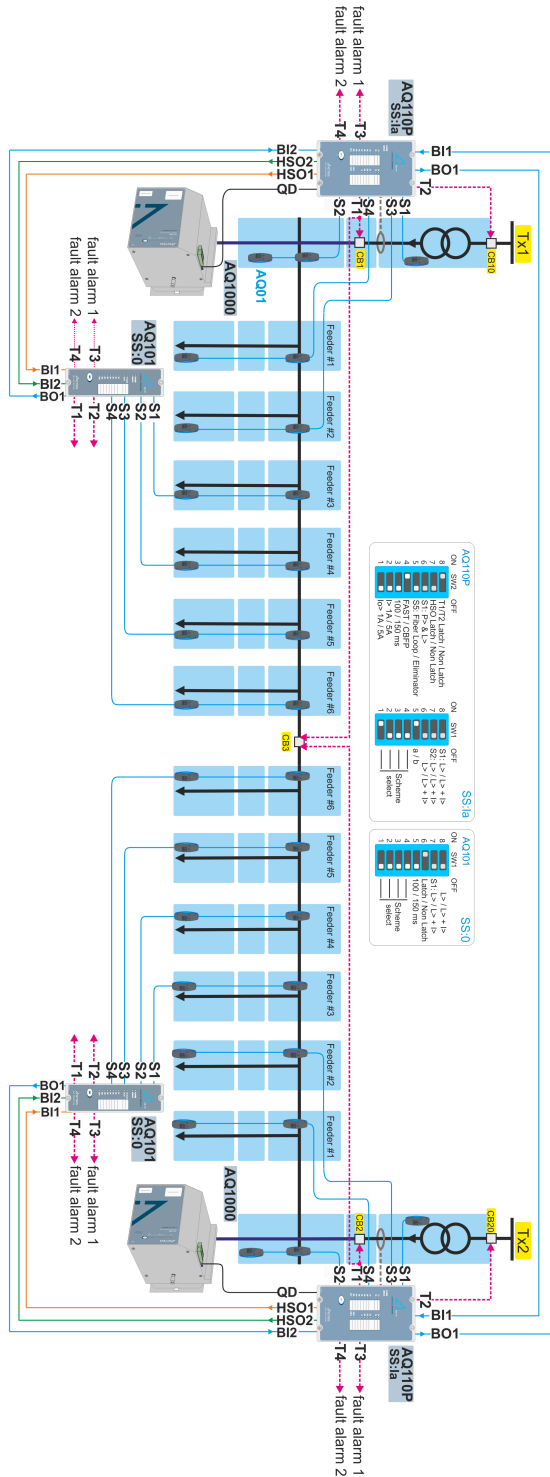

9.1.4 Two incomers with a tie breaker (shared I>)

NOTE!

The two AQ-110P units in this application share the overcurrent signal (I>) between them.

Figure. 9.1.4 - 26. Application with two incomers and a tie breaker.

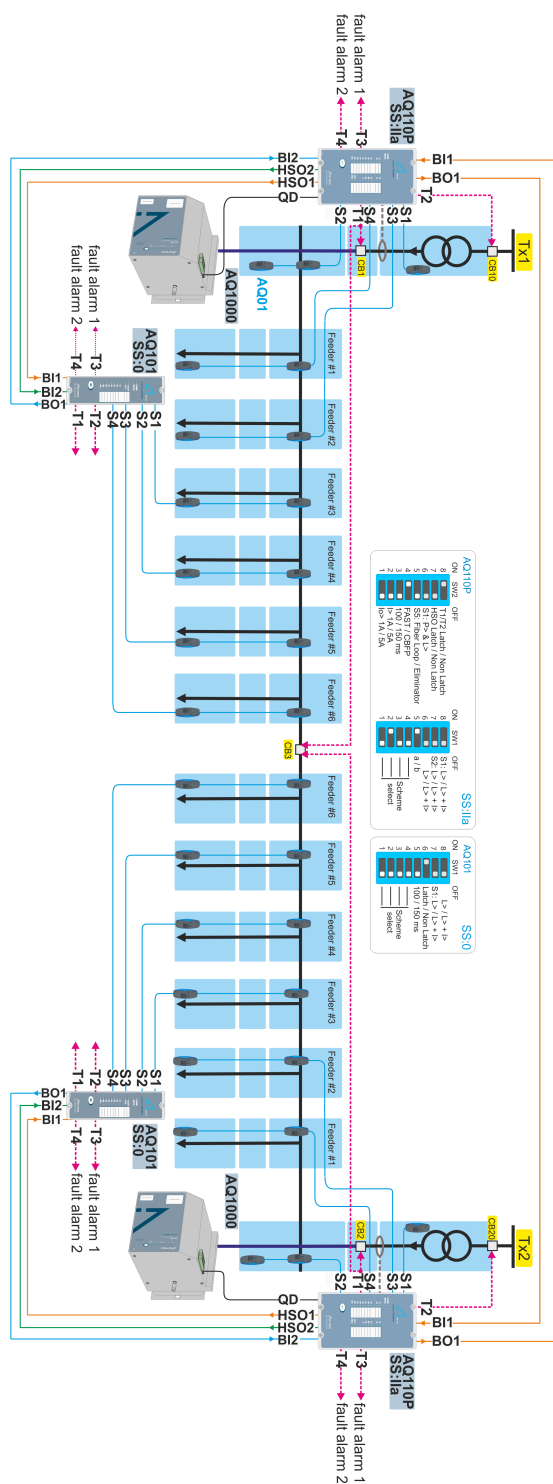

9.2 Medium-voltage arc protection applications

9.2.1 One incomer (feeder selective)

NOTE!

Please note that there is another MV application titled "One incomer", differentiated by whether or not they are feeder selective. In this application the scheme selected with AQ-101 is SS:4, and this means that this application is feeder selective. When the sensor channel S1 of an AQ-101 unit detects light, T1 sends a tripping signal only to its breaker. Similarly, when the sensor channel S2 detects light, T2 sends a tripping signal only to its breaker.

Figure. 9.2.1 - 27. Application with one incomer.

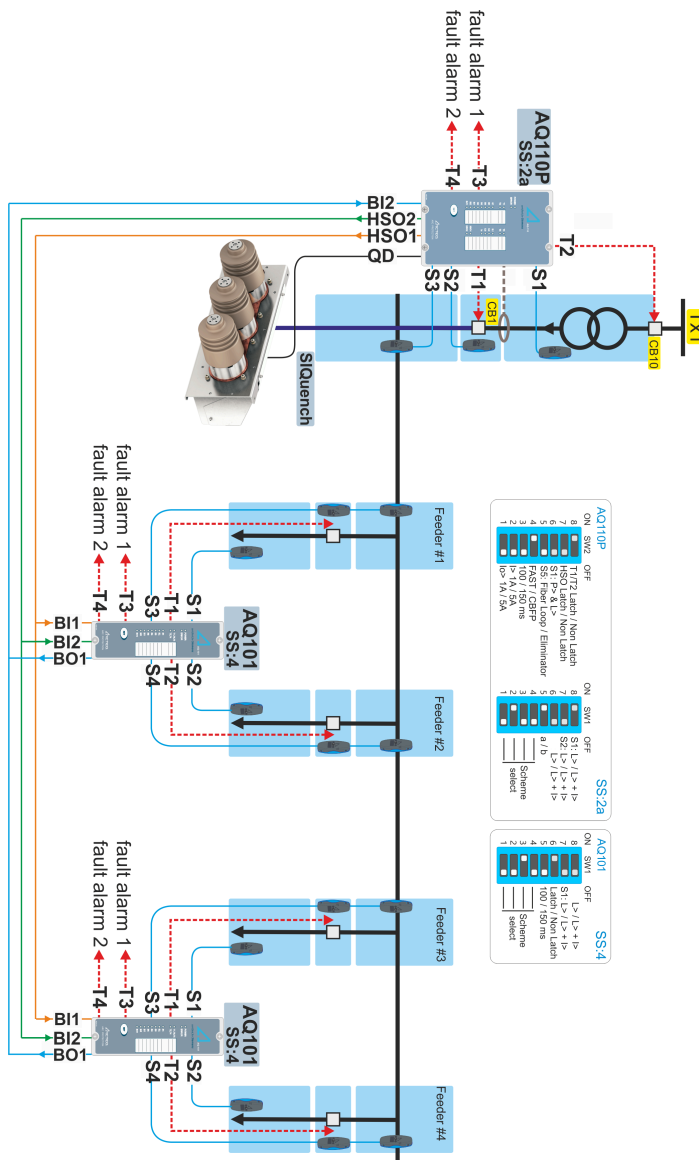

9.2.2 Two incomers without a tie breaker (feeder selective)

NOTE!



Please note that there is another MV application titled "Two incomers without a tie breaker", differentiated by whether or not they are feeder selective. In this application the scheme selected with AQ-101 is SS:4, and this means that this application is feeder selective. When the sensor channel S1 of an AQ-101 unit detects light, T1 sends a tripping signal only to its breaker. Similarly, when the sensor channel S2 detects light, T2 sends a tripping signal only to its breaker.

Figure. 9.2.2 - 28. Application with two incomers without a tie breaker.

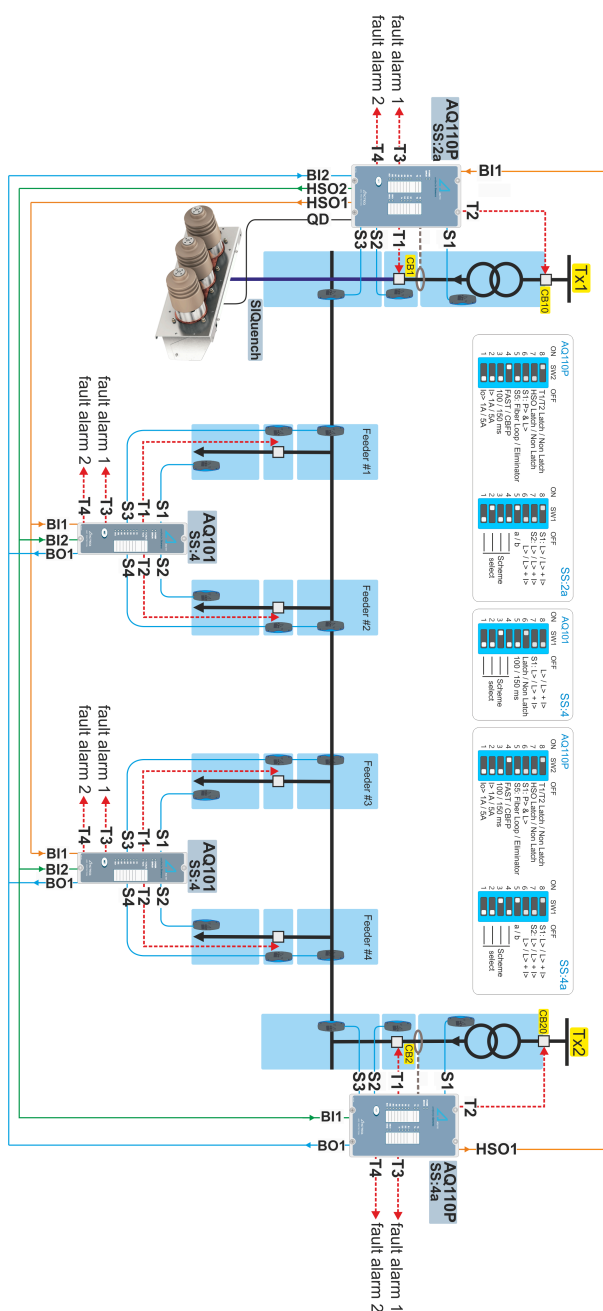

9.2.3 One incomer (non-feeder selective)

NOTE!



Please note that there is another MV application titled "One incomer", differentiated by whether or not they are feeder selective. In this application the scheme selected with AQ-101 is SS:0, and this means that this application is **not** feeder selective. When the sensor channel S1 of an AQ-101 unit detects light, both T1 and T2 send a tripping signal to their respective breakers at the same time.

Figure. 9.2.3 - 29. Application with one incomer.

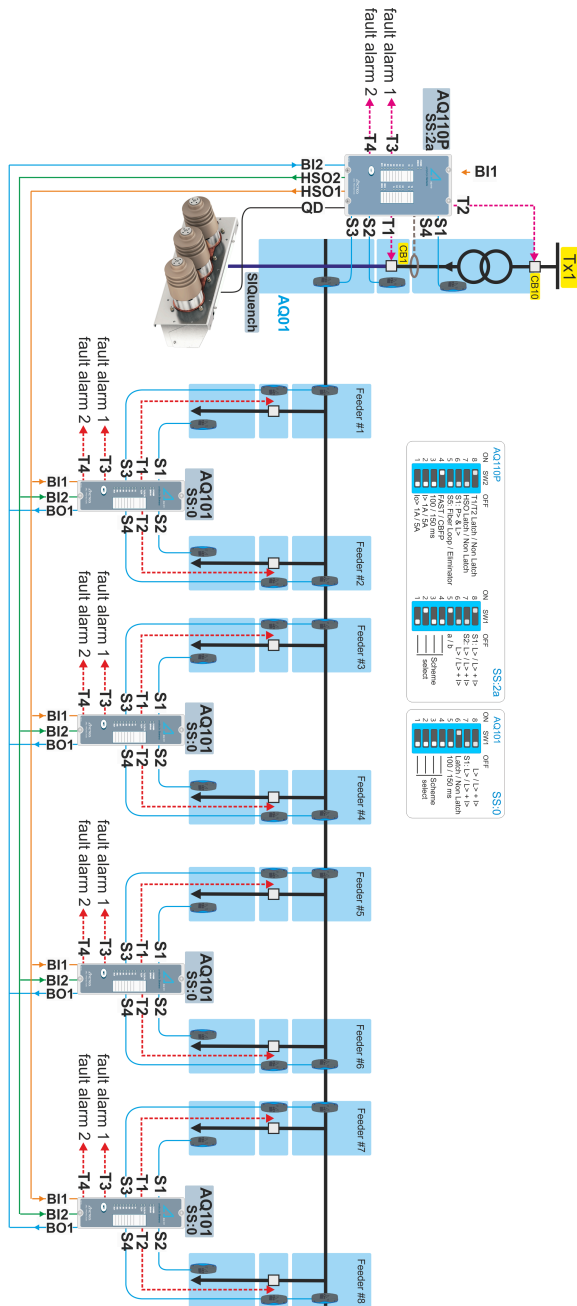

9.2.4 Two incomers without a tie breaker (non-feeder selective)

NOTE!



Please note that there is another MV application titled "Two incomers without a tie breaker", differentiated by whether or not they are feeder selective. In this application the scheme selected with AQ-101 is SS:0, and this means that this application is **not** feeder selective. When the sensor channel S1 of an AQ-101 unit detects light, both T1 and T2 send a tripping signal to their respective breakers at the same time.

Figure. 9.2.4 - 30. Application with two incomers without a tie breaker.

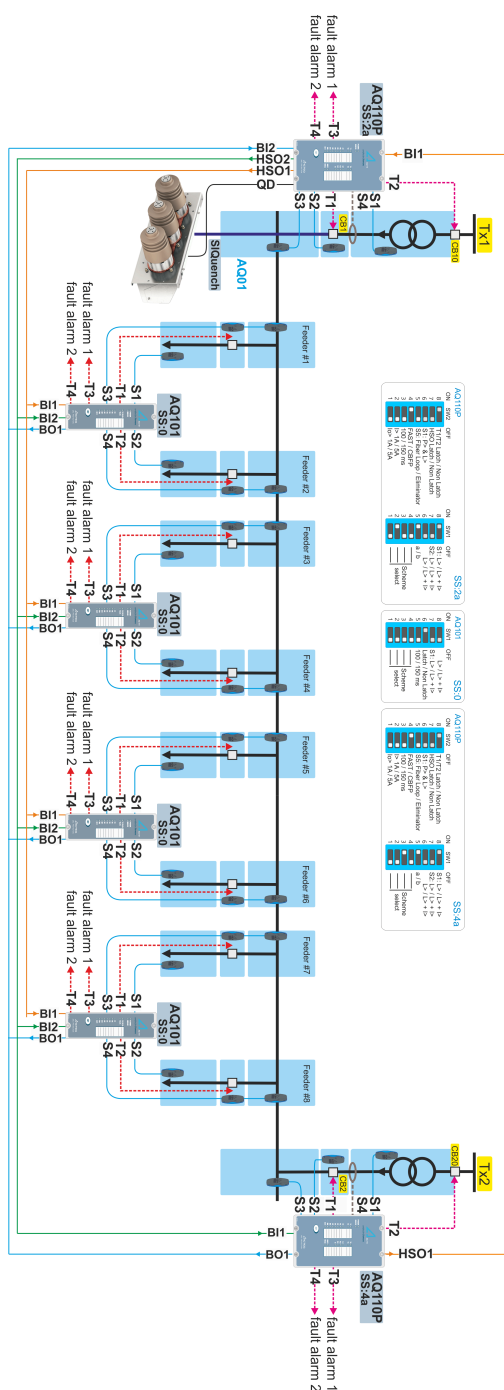

9.2.5 Two incomers with a tie breaker

Figure. 9.2.5 - 31. Application with two incomers with a tie breaker.

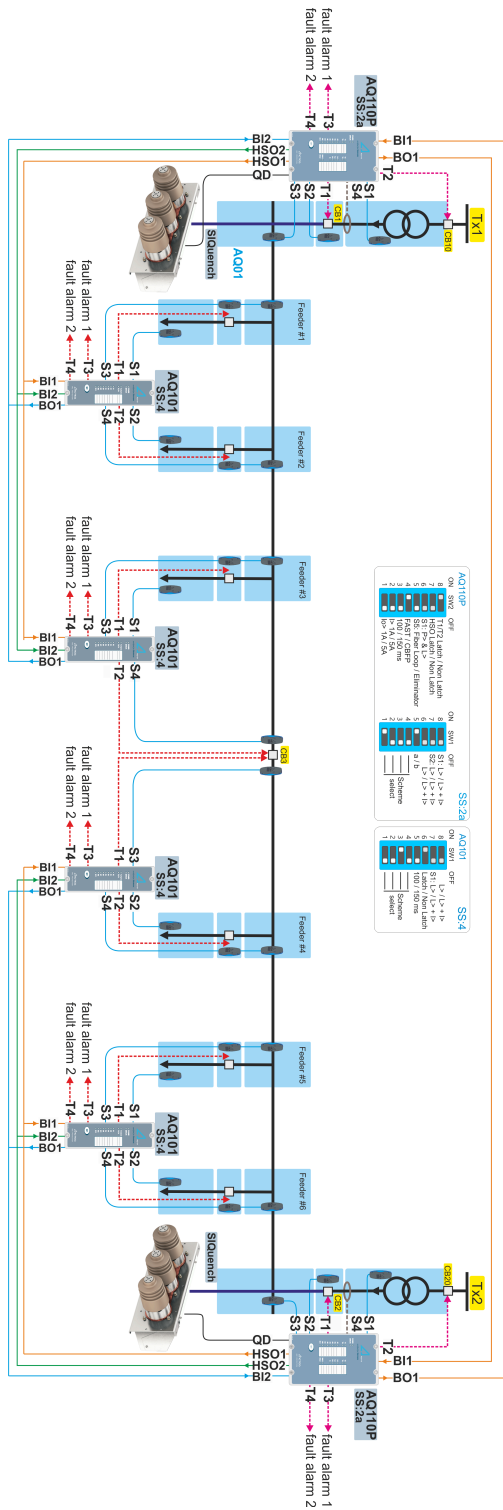

10 Troubleshooting

Table. 10 - 28. Troubleshooting.

LED	State	State of "Error" LED	State of SF relay	Possible issues
A binary input <u>or</u> a sensor channel	Blinking	ON	OFF	There is a bad connection between sensors or other devices connected to a binary input <u>or</u> There is a damaged wire. <u>or</u> The number of units or sensors has changed.
"Power"	OFF	ON	OFF	The internal voltage is too low, and the auxiliary supply voltage may be less than specified.
	Blinking	OFF	OFF	The connections of the input channels (binary inputs and sensors) need to be verified; see Chapter 6.1.3 ("SET button").
Other LEDs than "Error"	OFF	ON	OFF	The DIP switch settings have changed. <u>or</u> The value of the current pick-up potentiometer has changed over 20 %. (Only applies to AQ-110P!)
All	OFF	OFF	OFF	The auxiliary supply voltage is not connected.

11 Technical data

11.1 Technical data of AQ-101, AQ-101D and AQ-110P

11.1.1 Mounting and installation

Table. 11.1.1 - 29. Technical data for relay mounting and installation.

Panel: - material - thickness (min...max)	metal 1.0...5.0 mm (0.04...0.20 in)
Panel mounting: - screw type - key size - tightening torque (min...max)	ISO 14581 M4x12, galvanized Torx T20 1.5...2.0 N·m (13.3...17.7 lbf·in)
Grounding: - nut type - key size - tightening torque (min...max)	DIN934-M5 galvanized 8 2.5...3.0 N·m (22.1...26.6 lbf·in)
Connectors X1 and X2: - connector type - wire cross section (min...max) - minimum stripping length - screw tightening torque (min...max)	Phoenix Contact MSTB 2,5/15-ST-5,08 0.2...2.5 mm ² (24...13 AWG) 7 mm (0.28 in) 0.5...0.6 N·m (4.4...5.3 lbf·in)
Connector X3: - wire cross section (min...max) - minimum stripping length - screw tightening torque (min...max)	0.5...6.0 mm ² (20...9 AWG) 14 mm (0.55 in) 0.5...0.6 N·m (4.4...5.3 lbf·in)
Fiber connectors: - nut tightening torque	light finger tightening

11.1.2 Operating times

Table. 11.1.2 - 30. Technical data for relay operating times.

Tripping time (HSO1-HSO2)	2 ms*
Tripping time (mechanical relays T1-T4)	7 ms*
Reset time after a trip criterion has been fulfilled: - light stage - overcurrent stage	1 ms 50 ms
Protection stages active after energization	50 ms (typically)

*) Total trip time when using arc light (L>) or overcurrent and light (I> + L>).

11.1.3 Auxiliary voltage

Table. 11.1.3 - 31. Technical data for the relay auxiliary voltage (Uaux).

Auxiliary power supply (min...max)	92...265 V AC/DC 18...72 V DC (optional)
Maximum interruption in the normal operating state	100 ms
Maximum power consumption	5 W (AQ-110P) 4 W (AQ-101, AQ-101D)

11.1.4 Current measurement circuits

Table. 11.1.4 - 32. Technical data for the current measurement circuits (IL1, IL2, IL3, IO).

Nominal current	1 A <u>or</u> 5 A
Rated frequency	2...1 000 Hz
Number of inputs	3 (phase) + 1 (residual)
Thermal withstand: - continuous - 10 s - 1 s	30 A 100 A 500 A
Setting range: - phase overcurrent - residual overcurrent	0.5...6.0 × I _N 0.005...2.000 × I _N
Measurement accuracy	10 %
Rated AC burden (VA)	Input resistance <10 mΩ

11.1.5 Trip relays

Table. 11.1.5 - 33. Technical data for the trip relays (T1, T2, T3, T4).

Number of trip relays	4 NO <u>or</u> 3 NO + 1 NC
Rated voltage	250 V AC/DC
Make and carry: - continuous - 3 s - 0.5 s	5 A (AC/DC) 16 A (DC) 30 A (DC)
Breaking capacity (DC)*	40 W (0.36 A at 110 V DC)
Contact material	AgNI 90/10

*) When the time constant L/R = 40 ms.

11.1.6 High-speed outputs

Table. 11.1.6 - 34. Technical data for the high-speed outputs (HSO1, HSO2).

Number of high-speed outputs	2
Rated voltage	250 V DC
Make and carry: - continuous - 20 s - 3 s - 0.5 s	0.5 A (DC) 2 A (DC) 6 A (DC) 15 A (DC)
Breaking capacity (DC)*	110 W (1 A at 110 V DC)
Contact material	Semiconductor

*) When the time constant $L/R = 40$ ms.

11.1.7 Binary output

Table. 11.1.7 - 35. Technical data for the relay binary output (BO1).

Number of binary outputs	1
Nominal voltage	24 V DC (internally supplied)
Maximum burden	20 mA / 480 mW

11.1.8 Binary inputs

Table. 11.1.8 - 36. Technical data for the relay binary inputs (BI1, BI2).

Number of binary inputs	2
Threshold voltage	24 or 110 or 220 V DC*
Rated current	3 mA

*) The binary input threshold voltage options depend on the device model. AQ-110P does **not** have options, and instead its binary input threshold voltage is always 24 V DC. Please refer to the ordering codes in Chapter 9.

WARNING!



Binary inputs are galvanically isolated from the device's grounding. The user must pay attention to avoid accidentally creating galvanic loops between binary inputs and the ground.

11.2 AQ-1000 arc quenching device

11.2.1 Mounting and installation

Table. 11.2.1 - 37. Technical data for quencher mounting and installation.

Tray: - material - thickness (recommended min)	steel tray plate 3.0 mm (0.118 in)
C-rail: - material - thickness (recommended min)	steel rail 2.0 mm (0.079 in)
Device and busbar mounting: - screw type - key size - tightening torque (min...max)	ISO 4762 M8x30, galvanized Allen key 6 20...25 N·m (177...221 lbf·in)
Connectors X1 and X2: - connector type - wire cross section (min...max) - minimum stripping length - screw tightening torque (min...max)	Phoenix Contact MSTB 2,5/15-ST-5,08 0.2...2.5 mm ² (24...13 AWG) 7 mm (0.28 in) 0.5...0.6 N·m (4.4...5.3 lbf·in)
Fiber connectors: - fiber model - fiber type	IF-D91B Arcteq AQ-001 multicore glass fiber

11.2.2 Device ratings

Table. 11.2.2 - 38. Technical data for AQ-1000 arc quenching device.

Maximum busbar voltage (line-to-line or line-to-earth)	1,000 V AC (50/60 Hz)
Maximum short circuit current	50 kA (for 1s) 75 kA (for 500 ms) 100 kA (for 200 ms)
Typical operating time	<3 ms
Maximum number of permitted operations: - loaded trip operations - no-load trip operations	2 100
BIL (phase contacts)	12 kV
AC dielectric voltage withstand (phase contacts)	2.5 kV AC (50/60 Hz)
Typical charging time of the energy storage: - from empty to full - from full to empty (no Uaux)	<10 min <15 min
Dimensions and weight: - device dimensions - weight (gross) - weight (net)	(see Chapter 12.2, "Dimensions") 20 kg (44.1 lbs) 16.5 kg (36.4 lbs)

NOTE!



For the BIL and typical charging time of other circuits, see their respective technical data chapters.

11.2.3 Auxiliary voltage

Table. 11.2.3 - 39. Technical data for the quencher auxiliary voltage (Uaux).

Auxiliary power, option A: - supply range (min...max) - impulse voltage withstand - AC dielectric voltage withstand	85...265 V AC/DC 5 kV (1.2/50 µs) 2 kV
Auxiliary power, option B: - supply range (min...max) - impulse voltage withstand - AC dielectric voltage withstand	18...72 V DC 1 kV (1.2/50 µs) 450 V
Maximum interruption	100 ms (Ready operating mode)
Maximum power consumption	5 W (Ready operating mode) 14 W (Charging mode)

NOTE!



For the auxiliary voltage options, see Chapter 13 ("Order codes").

11.2.4 Signal relays

Table. 11.2.4 - 40. Technical data for the quencher signal relays (Trip, Ready, Blocked, Charging).

Number of signal relays	4 NO
Rated voltage	250 V AC/DC
Impulse voltage withstand AC dielectric voltage withstand	5 kV (1.2/50 µs) 2 kV
Continuous carry	5 A AC/DC
Contact material	AgNi 90/10

11.2.5 Binary inputs

Table. 11.2.5 - 41. Technical data for the quencher binary inputs (BI1, BI2, BI3, BI4).

Number of binary inputs	4
Nominal activation voltage (min...max)	24...240 V DC
Threshold voltage	24 V DC
Impulse voltage withstand AC dielectric voltage withstand	5 kV (1.2/50 μ s) 2 kV
Rated current	3 mA

WARNING!

Binary inputs are galvanically isolated from the device's grounding. The user must pay attention to avoid accidentally creating galvanic loops between binary inputs and the ground.

11.2.6 Environmental ratings

Table. 11.2.6 - 42. Technical data for the quencher environmental ratings.

Operating temperature (min...max)	-5...+70 °C (23...158 °F)
Maximum humidity	95 % (no condensation allowed)
Storage temperature (min...max)	-40...+85 °C (-40...185 °F)

11.3 Arc flash sensors

Table. 11.3 - 43. Technical data for arc flash sensors.

Light intensity threshold options	8,000 lx 25,000 lx 50,000 lx
Pressure threshold (fixed)	0.2 bar above ambient pressure
Pressure measuring accuracy	+/- 1.8 % (of full scale)
Allowed detection range	180°
Supply voltage	24 V DC
Supply current (standby)	2 mA
Pick-up time*	<1 ms
Sensor cable specifications: - type - size - cable cover diameter	shield twisted pair 0.75 mm ² (18 AWG) 4.5...6.0 mm (0.18...0.24 in)
Maximum sensor cable length per sensor channel	200 m (656 ft)
Temperature: - operating temperature - storage temperature	-20...+85 °C (-4...+185 °F) -20...+85 °C (-4...+185 °F)
Mechanical protection	IP 20
Mounting: - screw type - screw diameter - screw length	e.g. Phillips Pan head screw M3 20 mm (0.79 in)
Dimensions (W × H × D)	90 × 27.5 × 32.5 mm (3.54 × 1.08 × 1.28 in)
Weight	20 g (0.705 oz)

*) The time for activation after exceeding the sensor's set light sensitivity level.

12 Dimensions

12.1 AQ-101, AQ-101D and AQ-110P

AQ-101 arc flash protection relay

Figure. 12.1 - 32. Device dimensions of AQ-101.

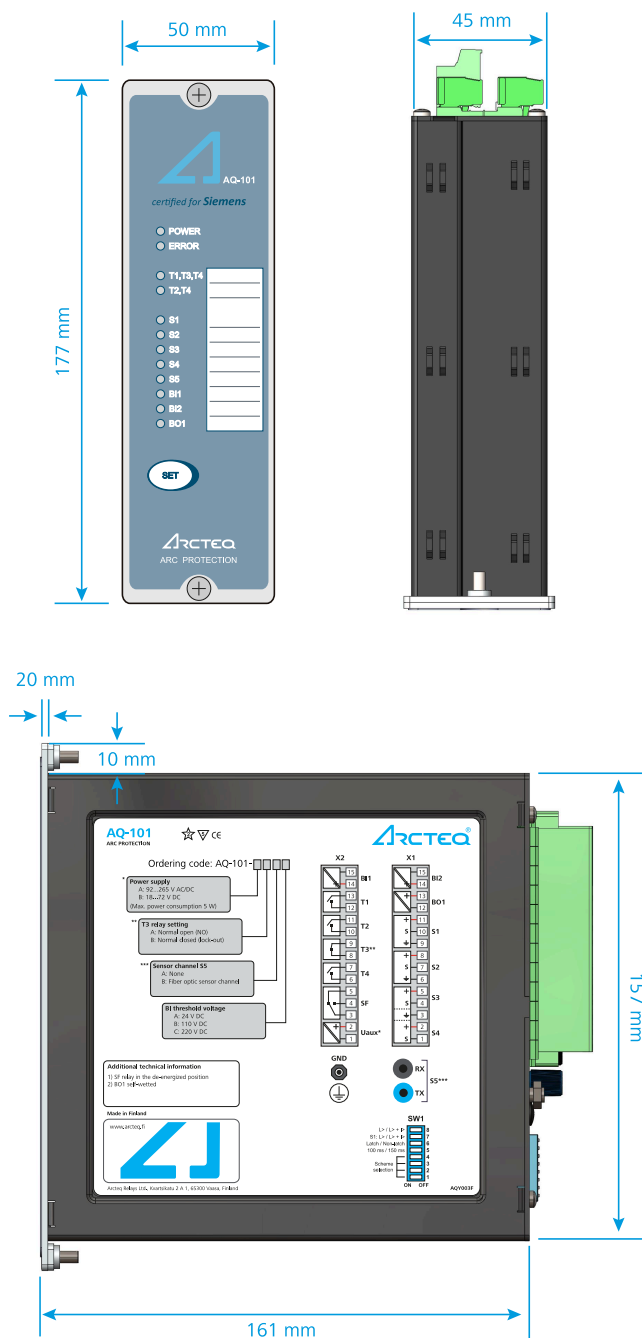
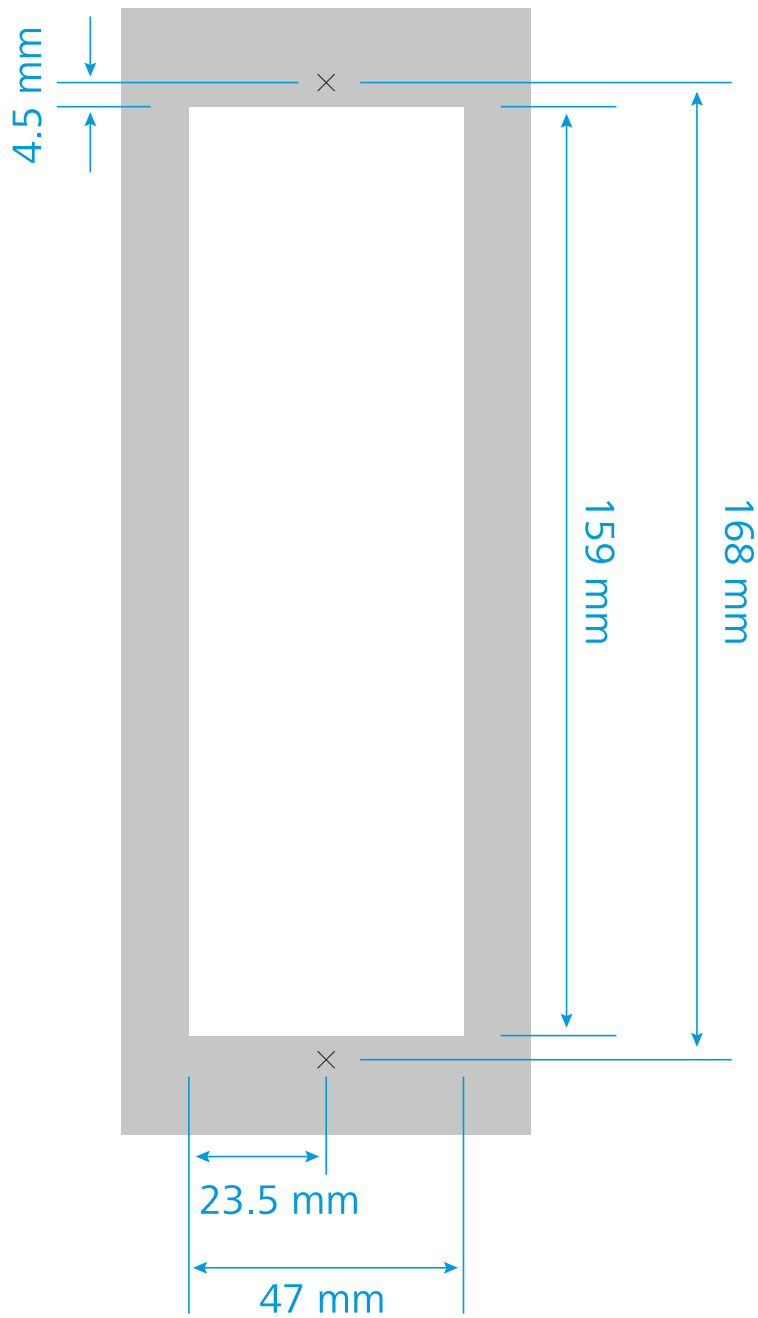
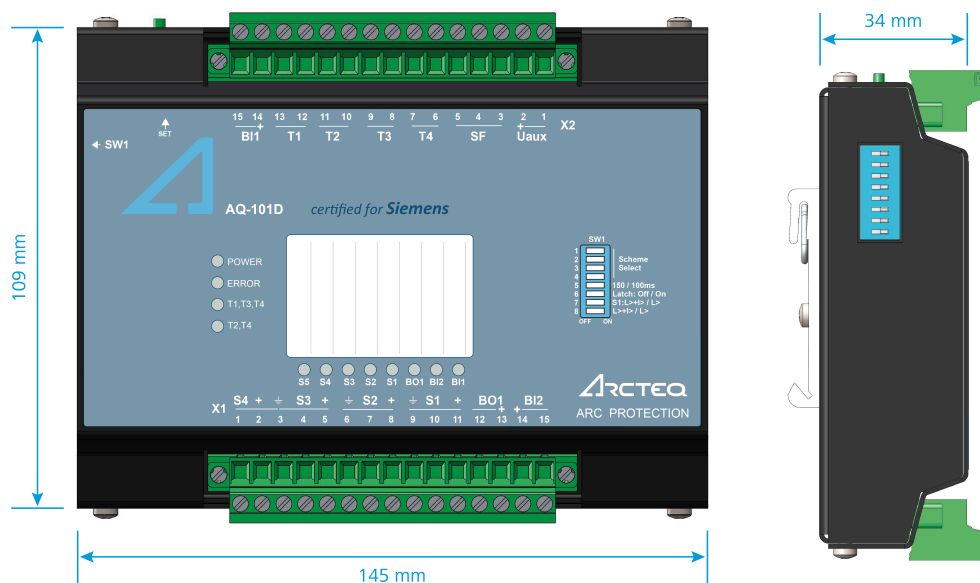

Figure. 12.1 - 33. Dimensions of AQ-101 panel cutout.



AQ-101D arc flash protection relay

Figure. 12.1 - 34. Device dimensions of AQ-101D.



AQ-110P arc flash protection relay

Figure. 12.1 - 35. Device dimensions of AQ-110P.

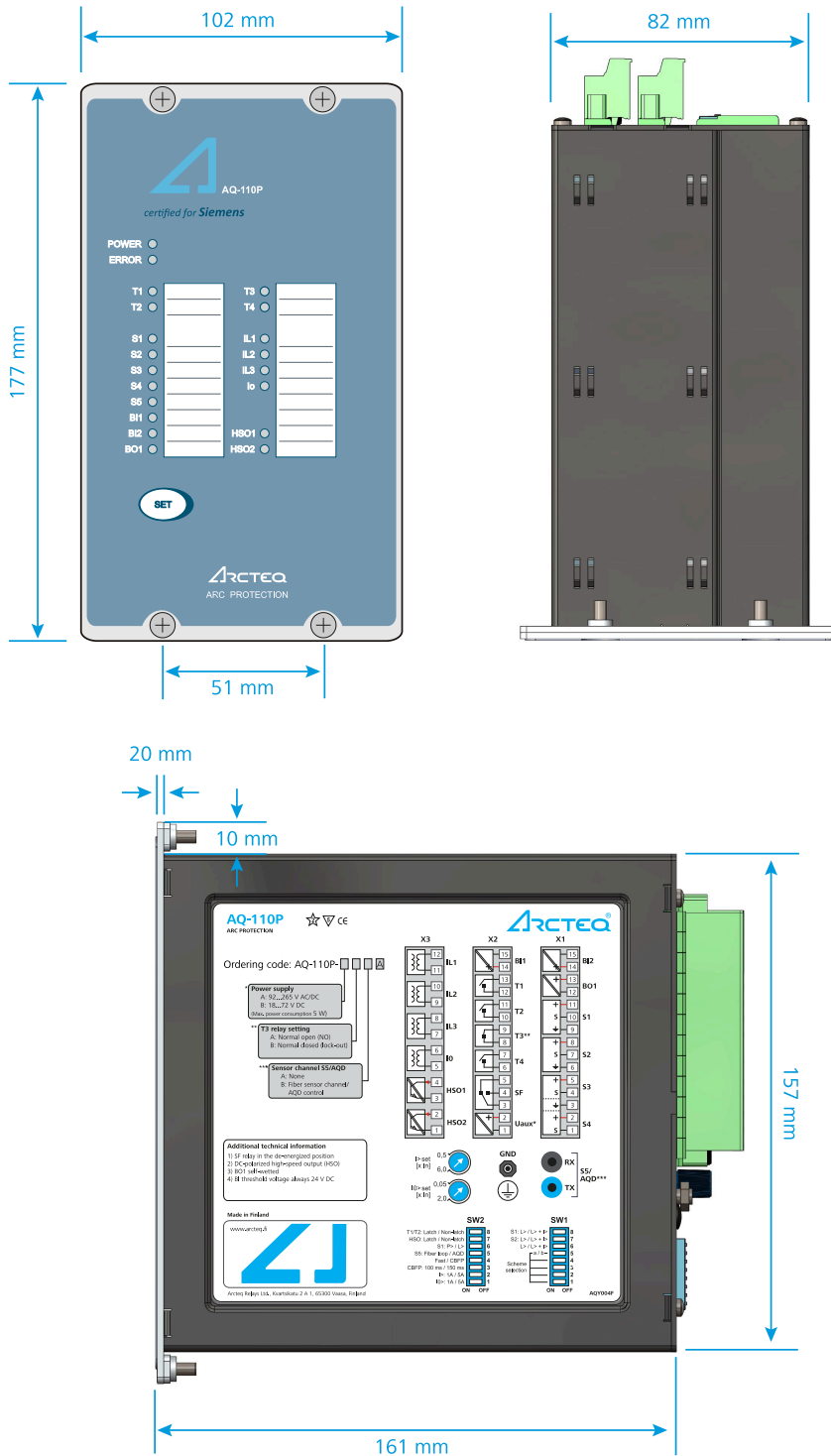
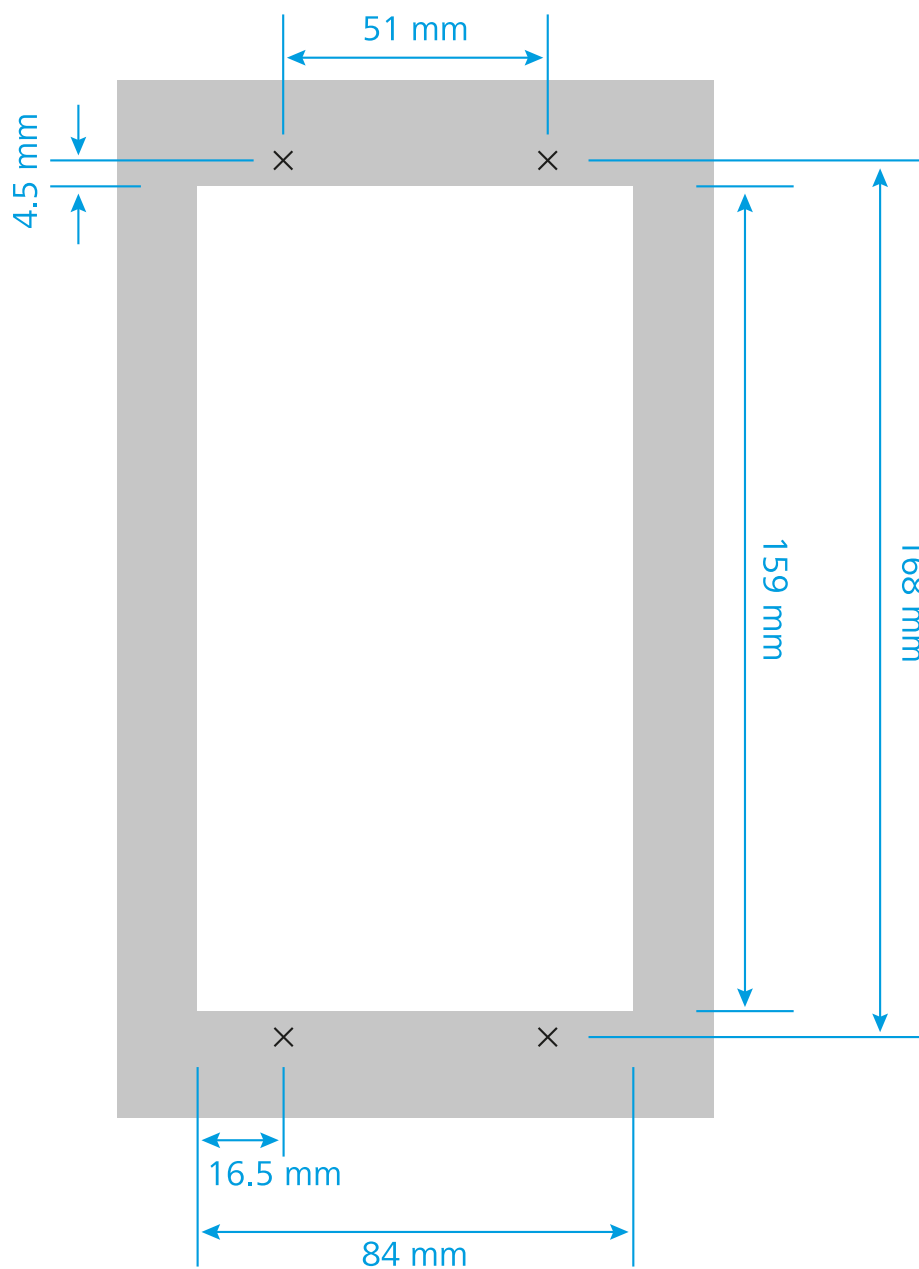

Figure. 12.1 - 36. Dimensions of AQ-110P panel cutout.



12.2 AQ-1000 arc queching device

NOTE!



See the technical instructions related to installation and mounting in Chapter 4.1.2 in the "Installation" chapter.

Figure. 12.2 - 37. Dimensions of AQ-1000 (when viewing the device from the front).



Figure. 12.2 - 38. Dimensions of AQ-1000 (when viewing the device from its left side).

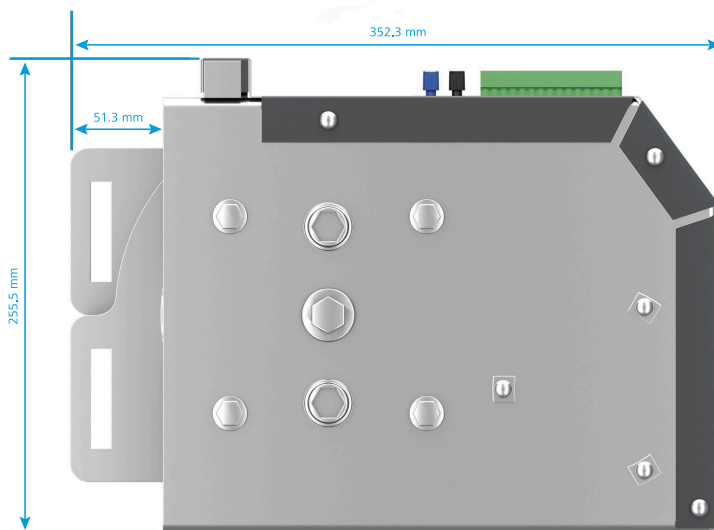

Figure. 12.2 - 39. Dimensions of AQ-1000 (when viewing the device from the rear panel).

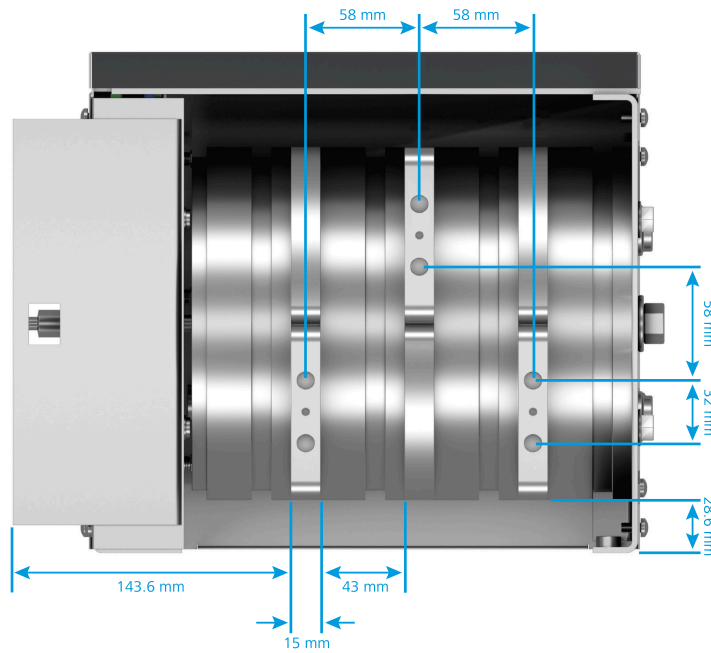

Figure. 12.2 - 40. Dimensions of AQ-1000 (when viewing the device from the bottom).

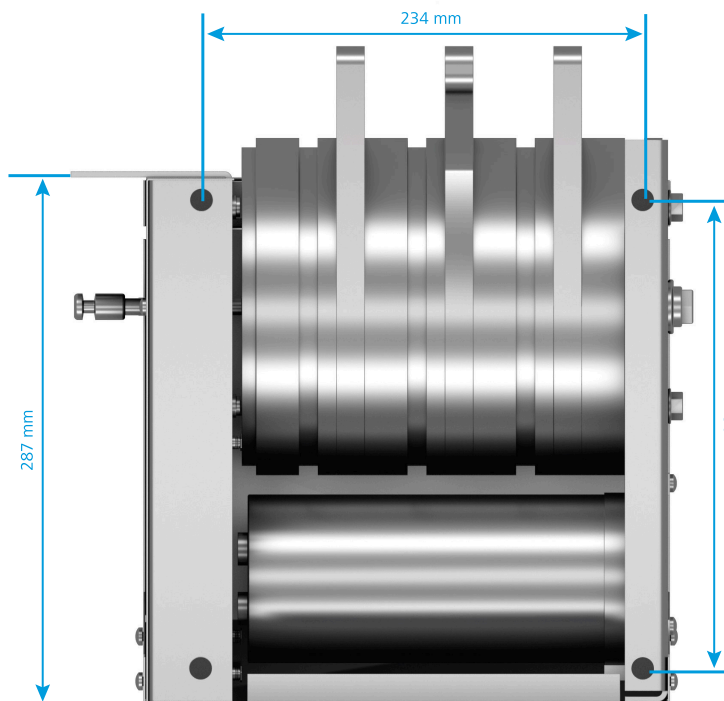
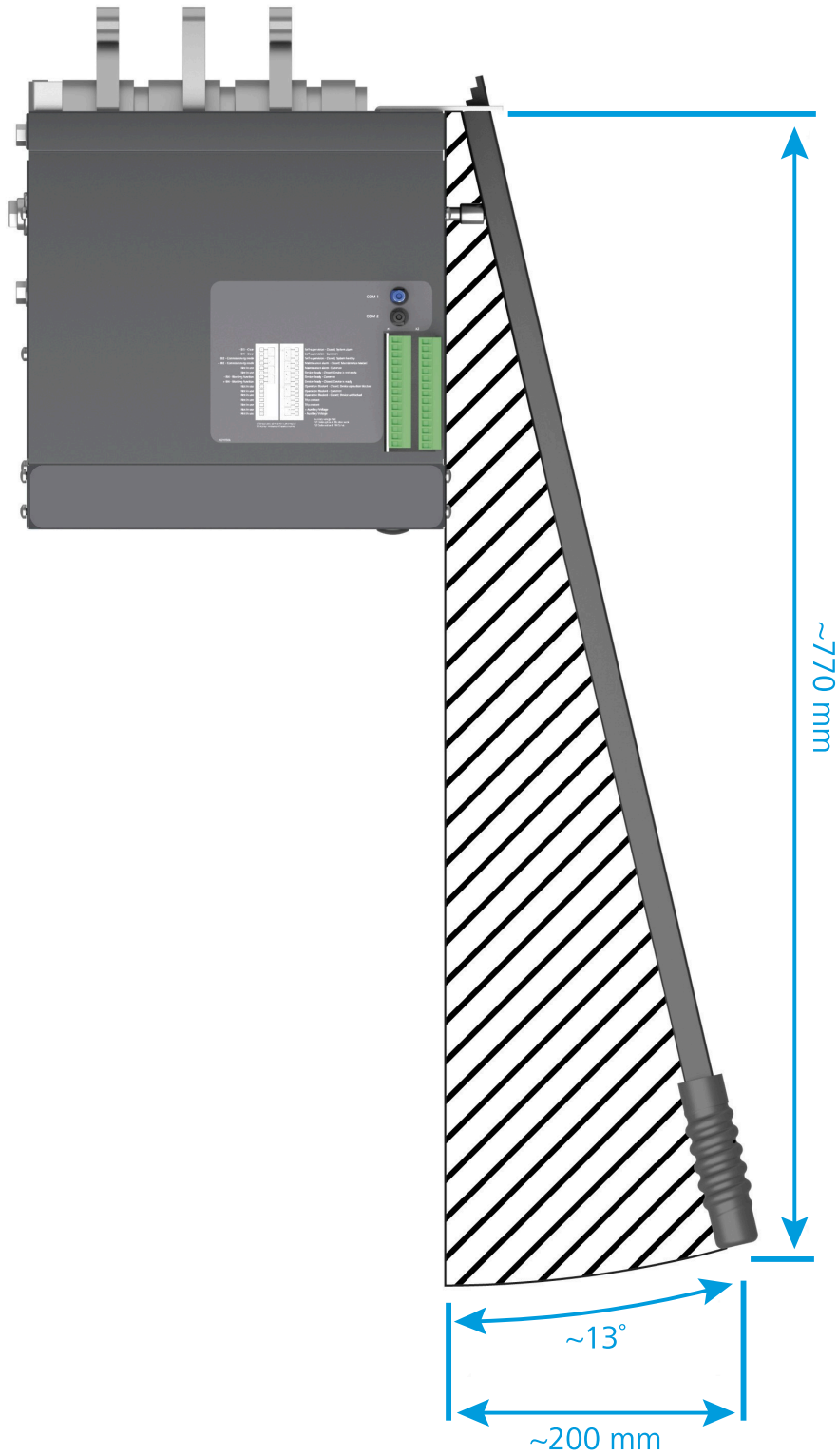
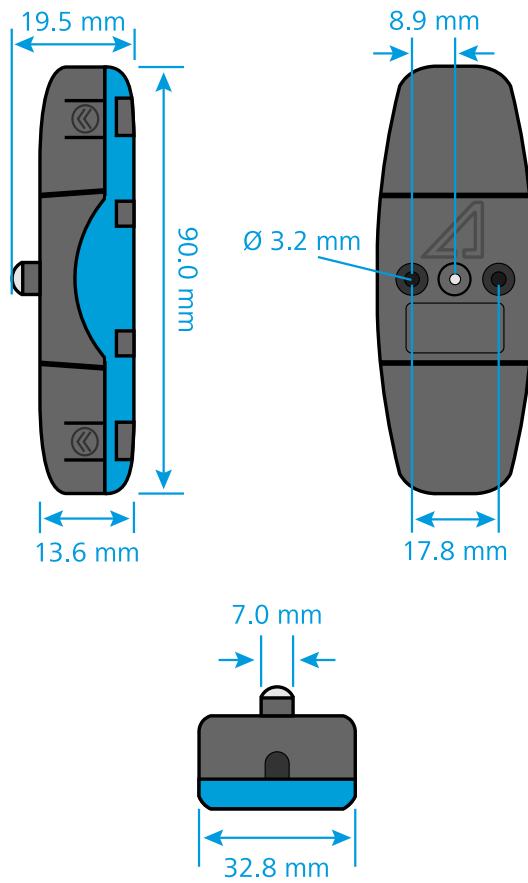

Figure. 12.2 - 41. Reset handle movement and its required space reservation.



12.3 Arc flash sensors

Figure. 12.3 - 42. Dimensions of arc flash sensors.



13 Order codes

Compatibility of the Siemens (-S) and Siemens Enhanced (-S-E) versions

Figure. 13 - 43. Compatibility of the Siemens (-S) and Siemens Enhanced (-S-E) versions between AQ-110P and AQ-1000.

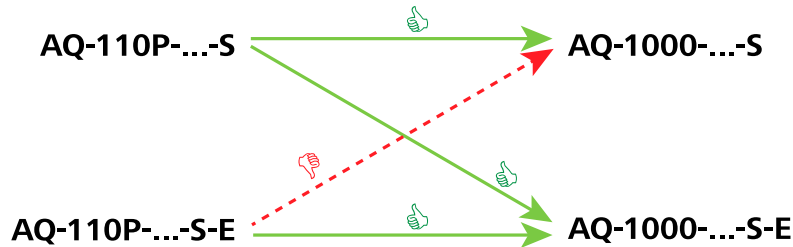
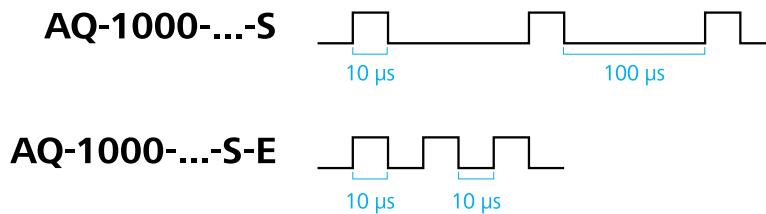
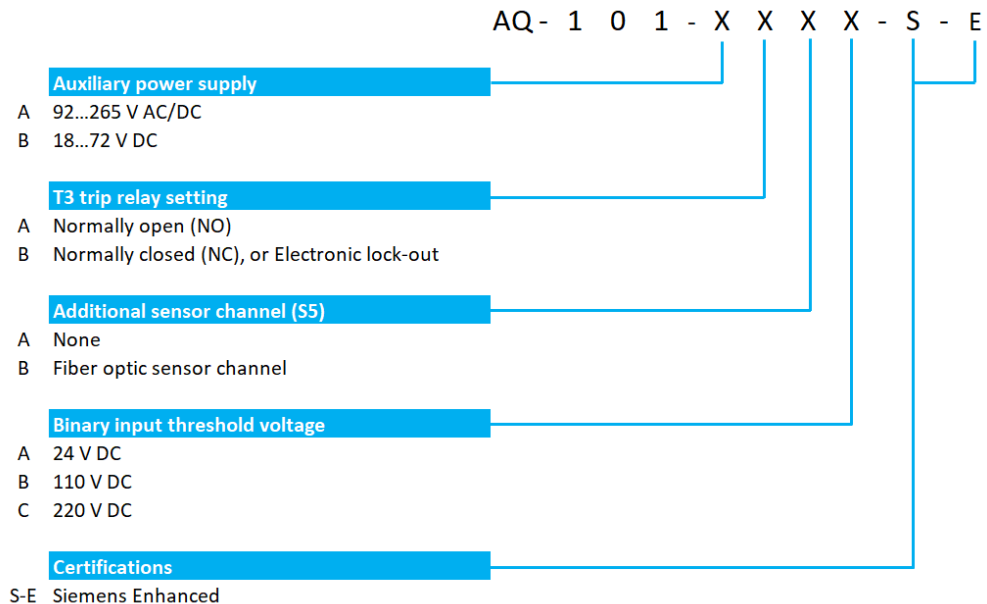

Figure. 13 - 44. Pulse duration of AQ-1000's Siemens (-S) and Siemens Enhanced (-S-E) versions.



AQ-101 arc flash protection relay



AQ-101D arc flash protection relay (DIN rail)

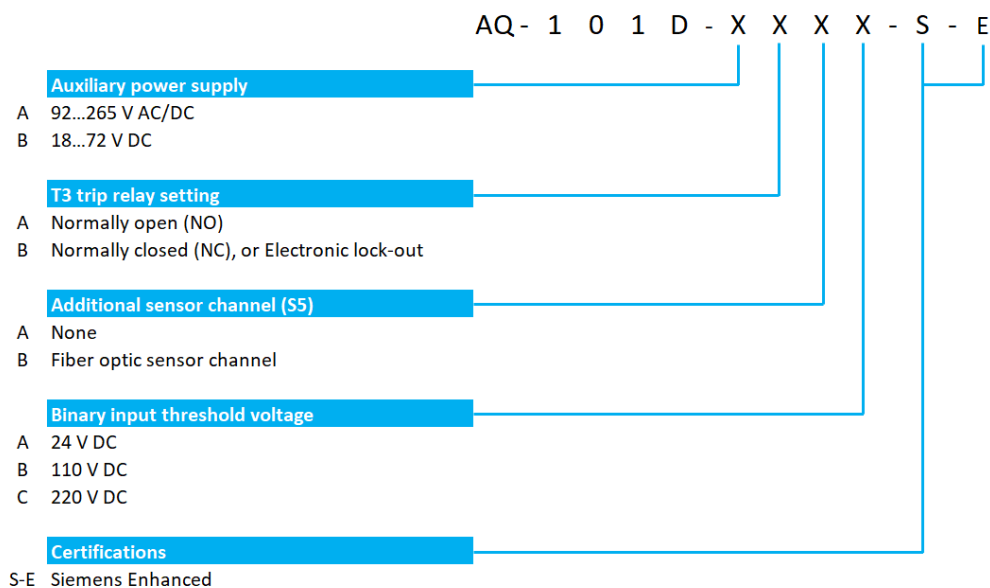

AQ-110P arc flash protection relay with overcurrent

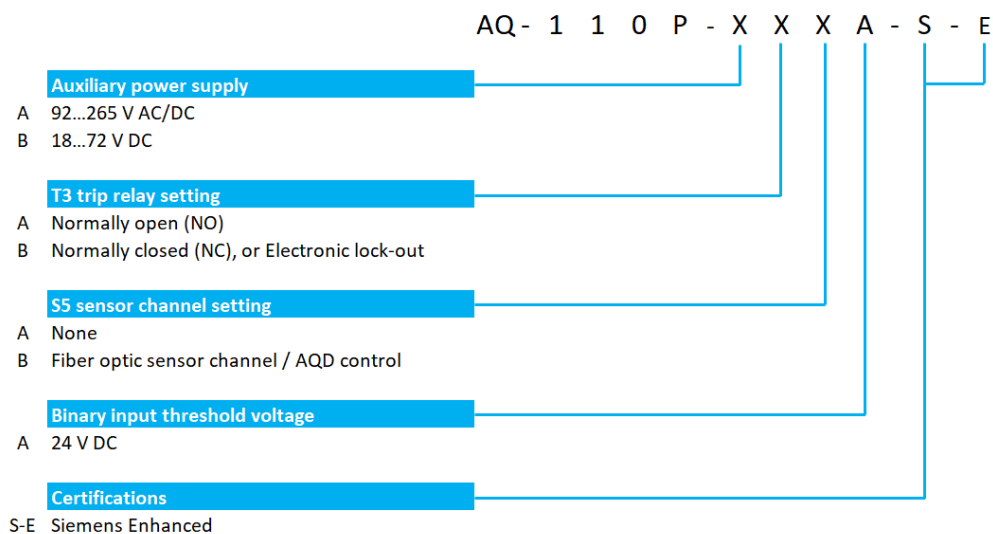

AQ-1000 arc quenching device

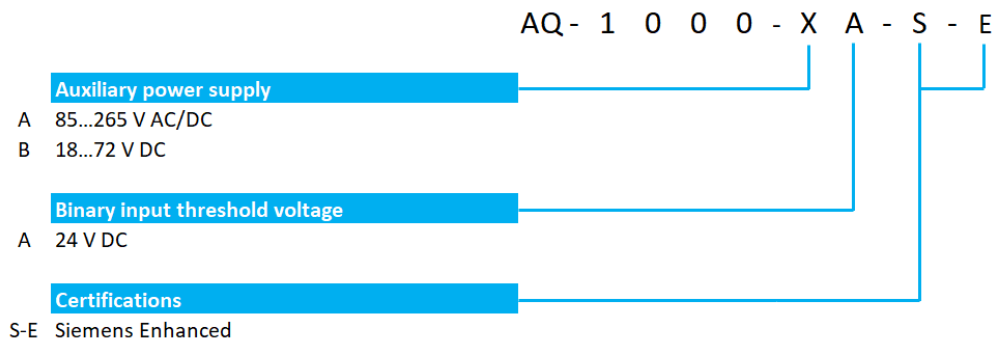

NOTE!



The arc quenching device is supplied with a connection fiber that is three (3) meters long. If a longer fiber is needed, it can be ordered separately according to the order code for the AX-001 connection fiber shown below.

NOTE!



The reset handle for AQ-1000 can also be ordered separately according to the order code shown below.

AX-001 connection fibers

AX - 0 0 1 - X

Connection fiber length

- 3 Three (3) meters
- 5 Five (5) meters
- 10 Ten (10) meters

AQ-1000 reset handle

SP - 1 0 0 0 - RST

RST

Reset handle for the AQ-1000 quenching device

Arc flash sensors

AQ - 0 X - X

Sensor function

- 1 Light point sensor
- 2 Pressure and light point sensor

Light activation level

- A 8,000 lx
- B 25,000 lx
- C 50,000 lux

14 Reference information

Manufacturer information:

Arcteq Relays Ltd.
Finland

Siemens customer support center:

Tel.: +49 180 524 70 00 (call charges depending on the provider)
Fax: +49 180 524 24 71
E-mail: support.energy@siemens.com

NOTE!



For more information regarding SIQuench© arc quenching device, please contact Siemens customer support center!

Siemens and SIQuench are registered trademarks of Siemens Aktiengesellschaft.